

3 1761 05474916 3

# ELECTRICITY IN THE SERVICE OF MAN

R. MULLINEUX WALMSLEY  
D. Sc. (Lond.), F.R.S.E.

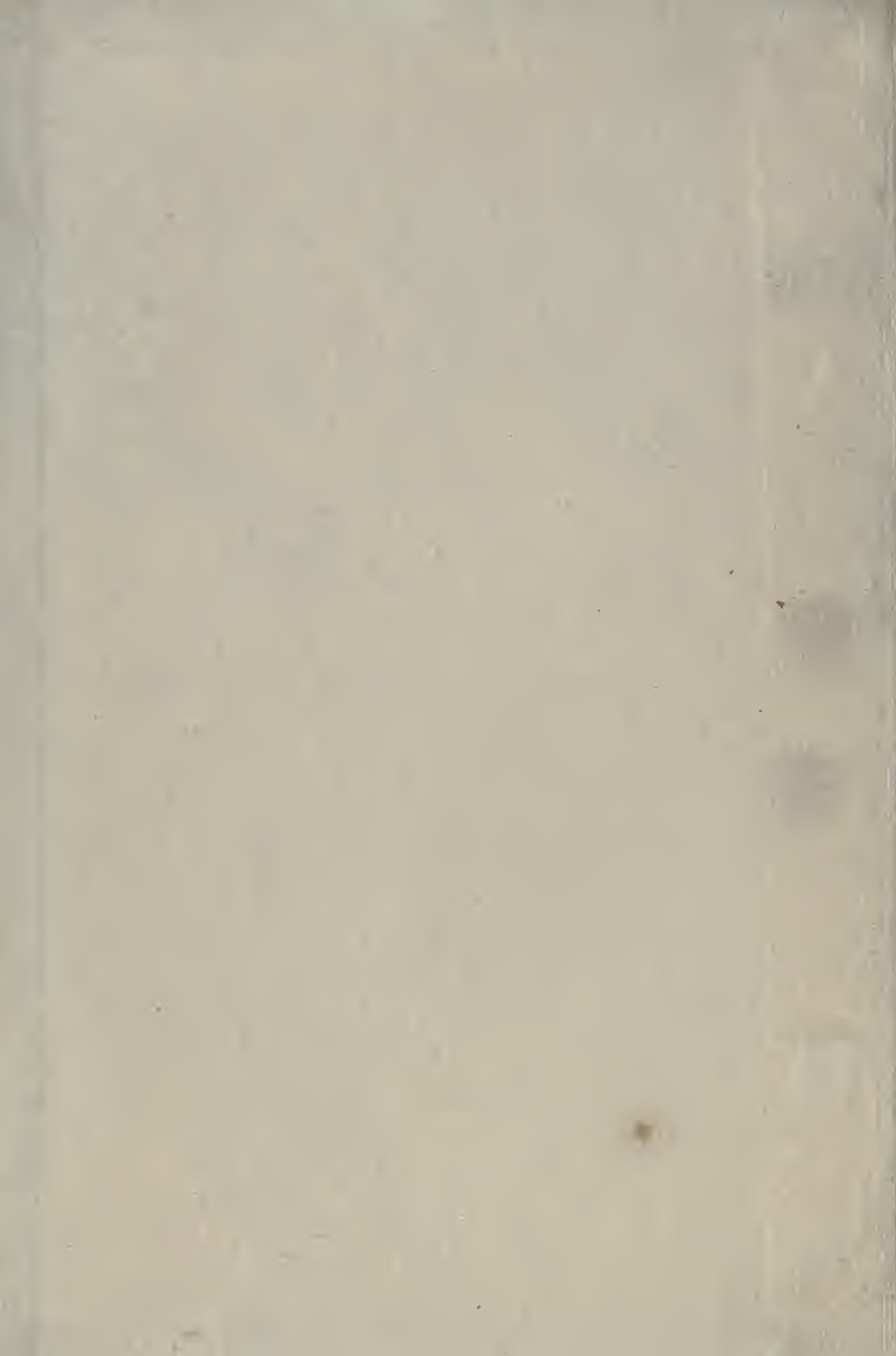





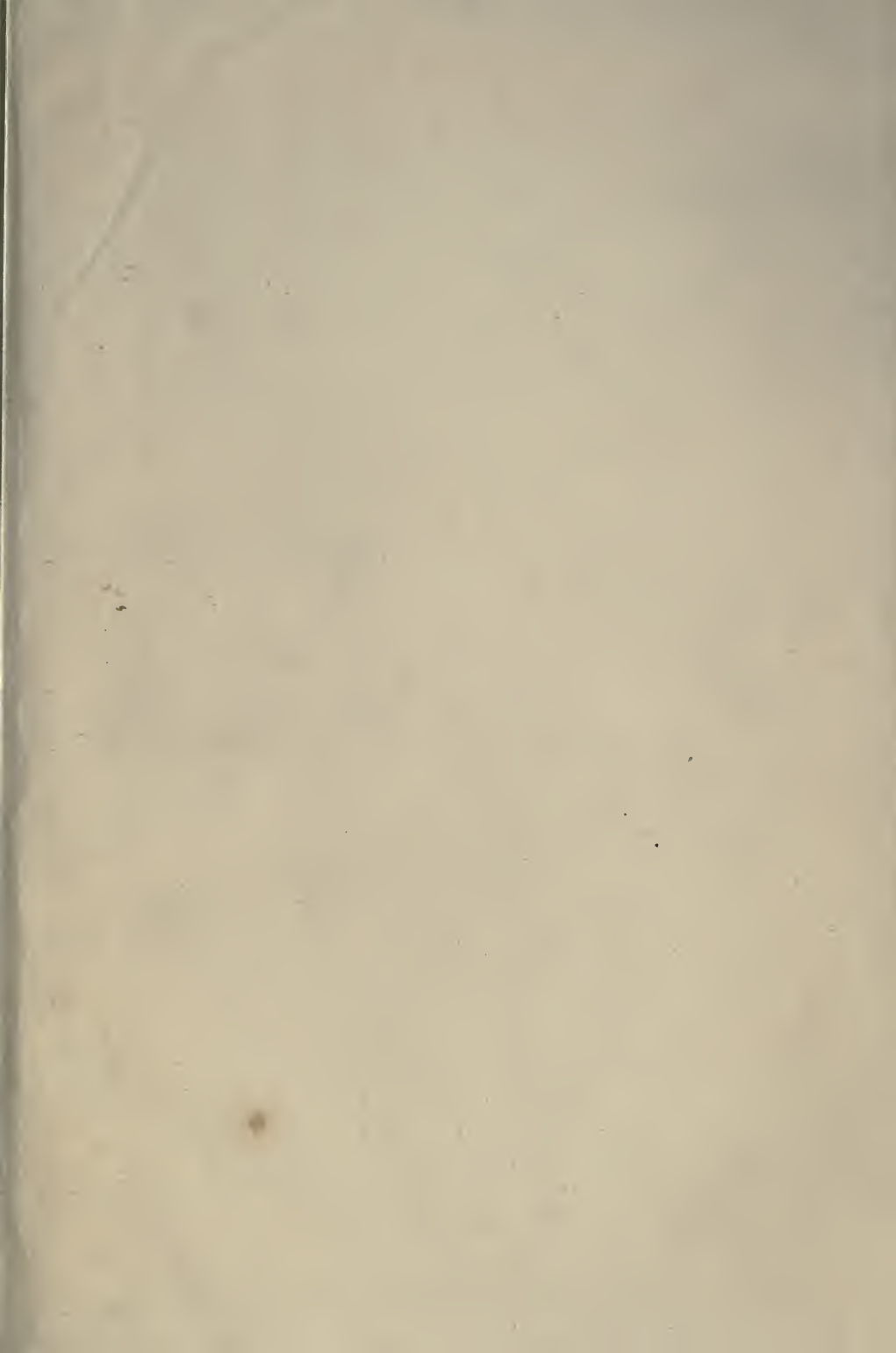



Digitized by the Internet Archive  
in 2007 with funding from  
Microsoft Corporation

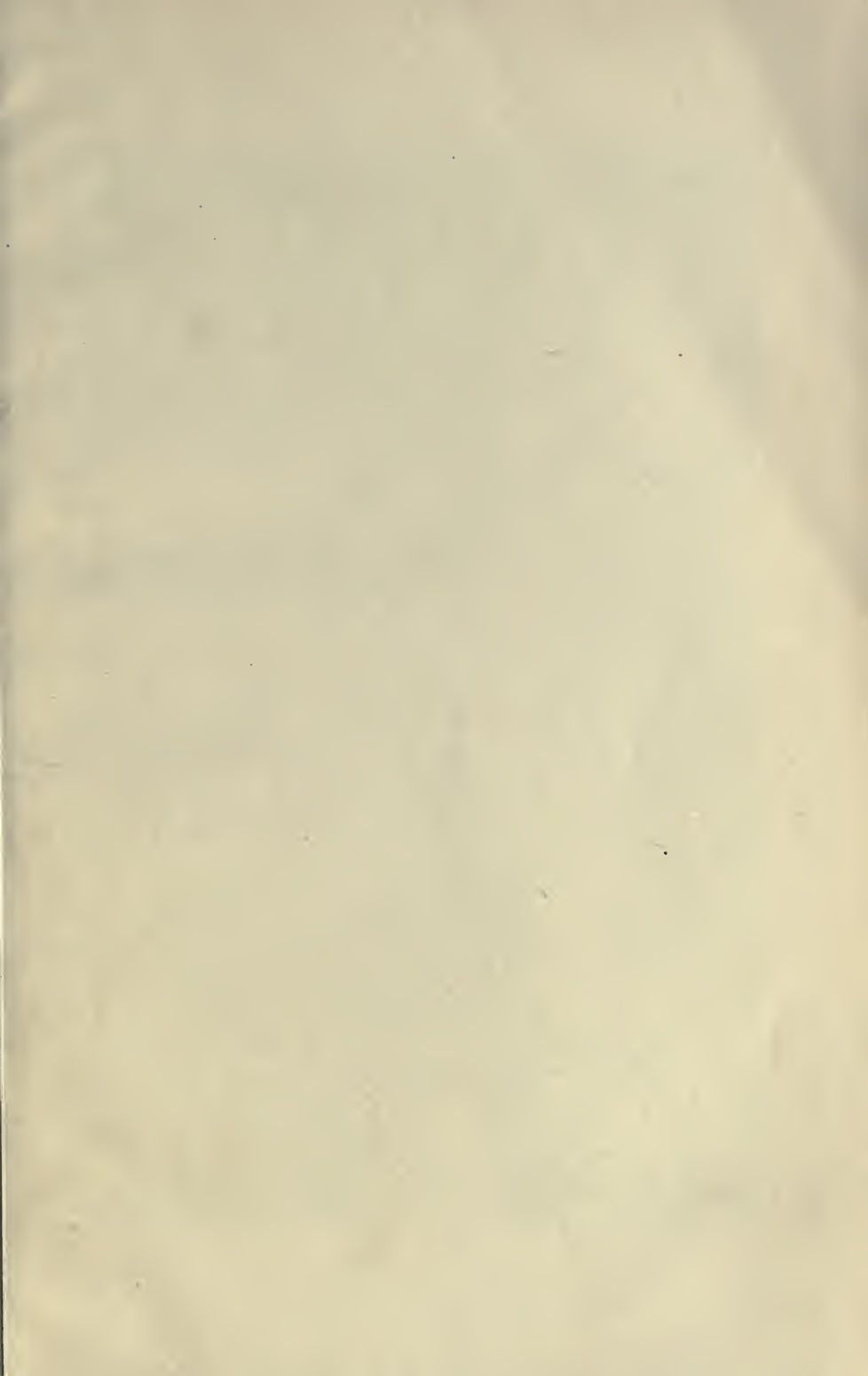



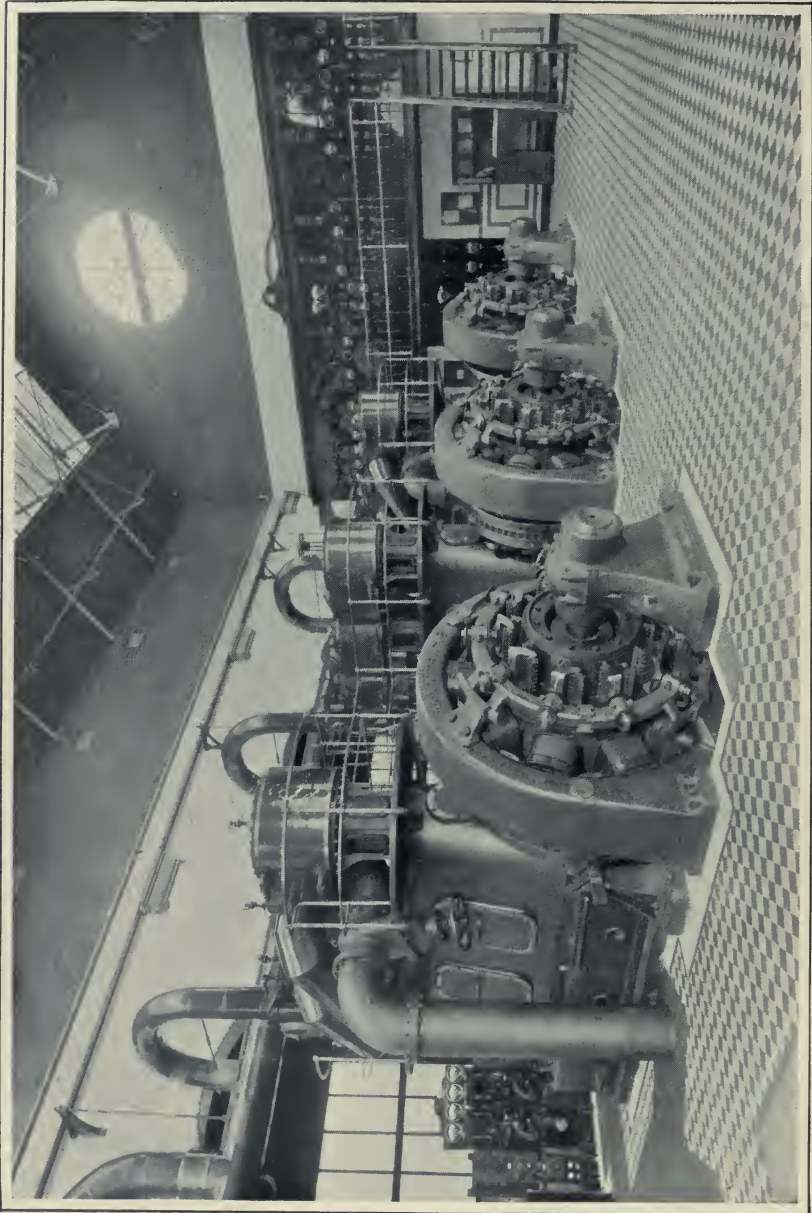

A MODERN ELECTRIC POWER GENERATING STATION.

Physics  
Elect  
W

# ELECTRICITY

IN THE

# SERVICE OF MAN

A POPULAR AND PRACTICAL TREATISE  
ON THE APPLICATIONS OF ELECTRICITY  
TO MODERN LIFE

BY

R. MULLINEUX WALMSLEY

D.SC. (LOND.), F.R.S.E.

Principal and Head of the Electrical Engineering Department of the Northampton  
Institute, London; Late Professor of Applied Physics and  
Electrical Engineering in the Heriot-  
Watt College, Edinburgh

WITH OVER 1,600 ILLUSTRATIONS.

152937  
21/10/19

VOLUME I

THE HISTORY AND PRINCIPLES OF ELECTRICAL SCIENCE

CASELL AND COMPANY, LTD.  
London, New York, Toronto and Melbourne  
1911 - 1913



New Edition  
First published in 1911.

ALL RIGHTS RESERVED



## PREFACE TO VOLUME I.

THE first edition of a work in the English language bearing the title of "Electricity in the Service of Man" appeared in 1888, and consisted chiefly of a translation from the German of Dr. A. R. von Urbanitzky, edited, with numerous additions, by Dr. R. A. Wormell. In 1890 a second edition was issued, first in serial form and then as a complete volume, still under the editorship of Dr. Wormell, but including some brief appendices from the pen of the present writer. The third edition followed rapidly, and was completed in 1893 under the direction of the present author, who contributed about 25 per cent. of the whole book as new matter, besides making large excisions from the previous edition and remodelling much of the remainder, so as to bring it more into line with modern ideas.

When in 1899 and 1900 the question of a new edition was discussed, so great had been the advance of electrical science in the few years which had elapsed since the previous issue that it had become necessary to recast the whole and practically to write a new book from cover to cover, discarding the old material except so far as it might be useful in the historical sections.

In undertaking this work the author, bearing in mind the much more general diffusion of electrical knowledge than had prevailed ten years earlier, decided to divide the body of the book into two parts, the first of which should deal with the "history and principles of electrical science," and the second with the "technology of electricity" under two subdivisions, which were to deal broadly with the applications involving the use of heavy and of small currents respectively. By this means it was hoped that one of the characteristics of the previous editions, which had been the subject of some criticism, would be avoided, inasmuch as it would render unnecessary the placing of explanations of quite elementary electrical principles in close juxtaposition to somewhat advanced developments of those

principles. The plan also had the further advantage that those who had already acquired some knowledge of electrical principles would be able to pass rapidly over the first part except in so far as they were interested in the historical developments. Moreover, by proper cross references the reader of the more technical sections would be able to refresh his knowledge of the principles when necessary, leaving those who were able to dispense with such references a clearer and more connected account of the technical developments.

The enormous and rapid growth of electrical science, together with some unforeseen personal experiences which are fully referred to in the preface to the last edition, rendered it impossible to carry out this scheme in its entirety. Following the plan of the two immediately preceding editions, the book was issued in serial numbers, the first of which appeared in October, 1901, Part I. of the whole work, as described above, being completed in August, 1902, and consisting of not quite 700 pages. The serial publication, owing to the circumstances alluded to above, had to be interrupted in the middle of Part II., the last serial number of which, with some modifications in the original plan, was not issued until June, 1904. The modifications referred to were rendered necessary by the rapid developments which had taken place since the issue of the preceding edition. Thus, in order to deal adequately with the subject of dynamos and motors, for continuous and alternate currents, nearly the whole of the space available was required, to the exclusion of many important subjects. It was decided to be better to treat this subject exhaustively, and to omit whole sections for treatment in a supplementary volume, rather than to attempt to cover the whole ground within insufficient space.

The issue of this contemplated supplementary volume has been delayed by various causes, until it has become necessary to issue a new edition of the whole work. In this new edition it has been decided to increase the available space considerably, and, as with this increase a single volume would be unwieldy, to divide the book into two volumes, to which the plan of the previous edition, with its Parts I. and II., readily adapted itself.

The present volume is therefore the new edition of Part I., and deals with "The History and Principles of Electrical Science." The portion dealt with has been thoroughly revised throughout, and, in addition to numerous alterations, many new pages have been added, so that, notwithstanding numerous deletions, the size of this section has increased from under 700 pages to over 800 pages. New sections have been added dealing with recent developments, amongst which may be mentioned "Radioactivity," "The Magnetic Properties of Alloys," "Metallic Filament Lamps," "The Mercury Arc," "Rectifiers," etc., etc., strictly technical details in all cases being left over for Volume II., in accordance with the general plan. In addition the chapters on "Electrical Measurements" at the end of the book have been considerably extended to bring them more into line with modern work and requirements, and some of the simpler measurements which were dealt with in Part II. in the last edition now appear more properly in Volume I. The reader of this volume, it is hoped, will obtain a very clear grasp of the fundamental principles and laws upon which the remarkable developments of the last two or three decades have been based, and with these to guide him will be able to follow as they appear most of the new applications of electricity to the service of man for some years to come.

Before concluding, the writer desires to express his deep obligations to many friends and manufacturers, and also to the technical press, for the invaluable assistance he has received on all hands in the course of the work. Most of the sources from which data have been derived, especially in the case of recent work, are acknowledged either directly or indirectly in the book, and it is therefore unnecessary to mention any of them specifically here. If, through inadvertence, any particular acknowledgment has not been made, the writer tenders his apologies and his assurances that such an omission is certainly not deliberate and intentional. For all assistance so received he is most grateful, as without it he would not have been able to carry out his plans.

R. MULLINEUX WALMSLEY.

*November, 1910.*



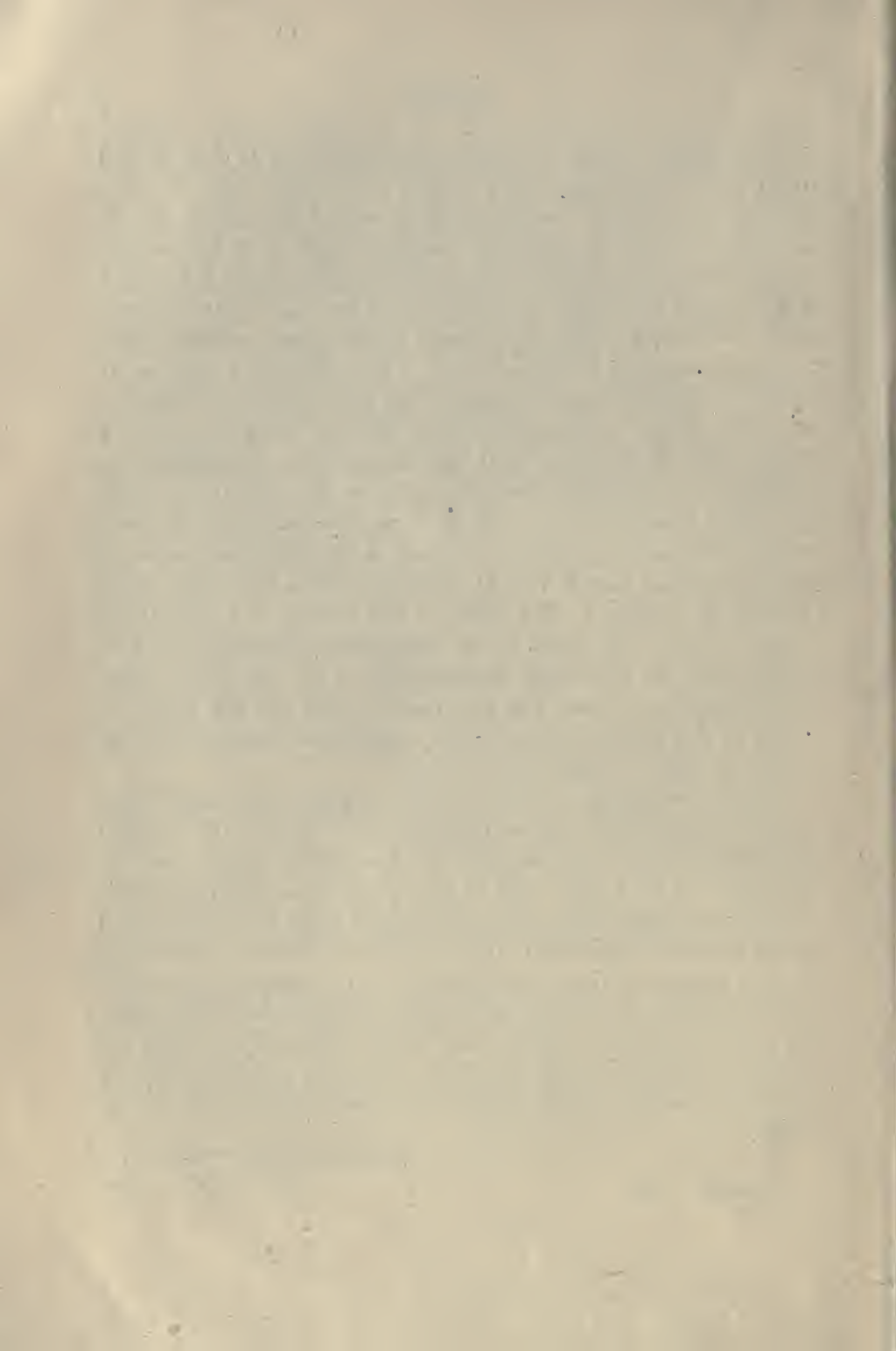

# CONTENTS

PAGE

## INTRODUCTION

EARLY HISTORY . . . . .	v
-------------------------	---

## CHAPTER I

### PRINCIPLES OF MAGNETISM

ELEMENTARY FUNDAMENTAL PHENOMENA . . . . .	14
MAGNETIC LAWS AND THEORY . . . . .	24
MAGNETIC CURVES AND LINES OF FORCE . . . . .	29
TERRESTRIAL MAGNETISM . . . . .	37

## CHAPTER II

### ELECTROSTATICS

ELEMENTARY FUNDAMENTAL PHENOMENA . . . . .	53
THE ELECTRIC FIELD . . . . .	65
ELECTRIC INDUCTION . . . . .	72
ELECTRICAL MACHINES. . . . .	85
INFLUENCE MACHINES . . . . .	88
STORAGE OF ELECTROSTATIC ENERGY (CONDENSERS) . . . . .	109
ELECTRICAL DISCHARGE AND SOME OF ITS EFFECTS . . . . .	127

## CHAPTER III

### THE ELECTRIC CURRENT

INTRODUCTORY . . . . .	143
THE CHEMICAL PRODUCTION OF THE ELECTRIC CURRENT. . . . .	146
THEORIES OF THE VOLTAIC CELL . . . . .	150
DEVELOPMENT OF THE PRIMARY CELL . . . . .	158
THE THERMAL PRODUCTION OF THE ELECTRIC CURRENT . . . . .	173

## CHAPTER IV

## ELEMENTARY LAWS OF SIMPLE CONTINUOUS CURRENTS

OHM'S LAW OF CURRENT FLOW . . . . .	180
RESISTANCE OF WIRES. . . . .	183
CONNECTING UP BATTERIES . . . . .	184
COMPLEX CIRCUITS . . . . .	187

## CHAPTER V

## THE CHEMICAL EFFECT OF THE CURRENT

FUNDAMENTAL PHENOMENA . . . . .	190
LAWS OF ELECTROLYSIS . . . . .	194
THEORIES OF ELECTROLYSIS. . . . .	197
SECONDARY BATTERIES . . . . .	200
ELECTRO-CHEMISTRY . . . . .	215

## CHAPTER VI

## THE THERMAL EFFECT OF THE CURRENT

FUNDAMENTAL LAWS . . . . .	222
INCANDESCENT OR GLOW LAMPS . . . . .	226
PHYSICS OF THE GLOW LAMP . . . . .	237
THE ELECTRIC ARC . . . . .	242
ARC LAMPS . . . . .	245
EFFICIENCY OF SOURCES OF LIGHT . . . . .	251
PHYSICS OF THE ELECTRIC ARC . . . . .	253
ELECTRIC FURNACES . . . . .	271

## CHAPTER VII

## THE MAGNETIC EFFECT OF THE CURRENT

ELEMENTARY LAWS . . . . .	275
ELECTRO-MAGNETISM . . . . .	280
PERMEABILITY . . . . .	285
MAGNETIC PROPERTIES OF IRON . . . . .	286
MAGNETIC PROPERTIES OF VARIOUS METALS . . . . .	300
EFFECTS OF TEMPERATURE . . . . .	304
CHANGE OF LENGTH OF MAGNETISM . . . . .	306
MAGNETIC PROPERTIES OF ALLOYS . . . . .	310
MAGNETISM AND LIGHT . . . . .	316
THEORIES OF MAGNETISM . . . . .	320



## CHAPTER VIII

PAGE

ELECTRO-MAGNETS . . . . .	33 <sup>o</sup>
---------------------------	-----------------

## CHAPTER IX

## SIMPLE MEASUREMENTS IN CONTINUOUS CURRENT CIRCUITS

QUANTITY OF ELECTRICITY . . . . .	341
ELECTRIC CURRENT . . . . .	344
ELECTRIC RESISTANCE . . . . .	355
ELECTRICAL PRESSURE . . . . .	362
ELECTRIC POWER . . . . .	377
ELECTRIC ENERGY . . . . .	380

## CHAPTER X

FURTHER APPLICATIONS OF THE EFFECTS OF THE CURRENT—  
THE ELECTRIC TELEGRAPH

EARLY HISTORY . . . . .	387
SIMPLE TELEGRAPHIC WORKING . . . . .	400
INSTRUMENTS . . . . .	407

## CHAPTER XI

## MAGNETO-ELECTRIC INDUCTION

FUNDAMENTAL PRINCIPLES AND HISTORY . . . . .	416
SELF-INDUCTION . . . . .	423
TRANSFER AND TRANSFORMATION OF ENERGY . . . . .	425
BATTERY INDUCTION COILS . . . . .	427
ALTERNATE CURRENT OR STATIC TRANSFORMERS . . . . .	433

## CHAPTER XII

## THE TELEPHONE

HISTORICAL NOTES . . . . .	443
THE ELECTRIC TRANSMISSION OF SPEECH . . . . .	450
MAGNETO-TELEPHONES . . . . .	454
MICROPHONE TRANSMITTERS . . . . .	459

## CHAPTER XIII

THE DYNAMICAL OR MAGNETIC PRODUCTION OF THE  
ELECTRIC CURRENT

EARLY HISTORY OF CONTINUOUS CURRENT DYNAMO MACHINES . . . . .	470
ELEMENTARY PRINCIPLES OF DYNAMO CONSTRUCTION . . . . .	479
CONTINUOUS CURRENT ARMATURES . . . . .	486
FIELD MAGNETS . . . . .	497
ELEMENTARY THEORY OF THE CONTINUOUS CURRENT DYNAMO . . . . .	507
LATER HISTORY OF CONTINUOUS CURRENT DYNAMOS . . . . .	518

## CHAPTER XIV

## ALTERNATE CURRENTS AND ALTERNATORS

ALTERNATE ELECTRIC CURRENTS . . . . .	535
ELEMENTARY LAWS OF SIMPLE ALTERNATE CURRENTS . . . . .	537
POLYPHASE CURRENTS . . . . .	548
SIMPLE POLYPHASE CIRCUITS . . . . .	552
ALTERNATORS . . . . .	554
RECTIFIERS. . . . .	565

## CHAPTER XV

## ELECTRIC TRANSMISSION OF POWER

FUNDAMENTAL PRINCIPLES . . . . .	572
SYSTEMS OF TRANSMISSION . . . . .	575

## CHAPTER XVI

## ELECTRIC MOTORS

HISTORICAL NOTES . . . . .	583
CONTINUOUS CURRENT MOTORS . . . . .	590
ELEMENTARY THEORY OF CONTINUOUS CURRENT MOTORS . . . . .	601
MONO-PHASE ALTERNATE CURRENT MOTORS . . . . .	606
ALTERNATE CURRENT INDUCTION MOTORS . . . . .	610

## CHAPTER XVII

KINETIC TRANSFORMERS . . . . .	628
--------------------------------	-----

## CHAPTER XVIII

## THE ELECTRIC DISCHARGE

NATURE OF THE DISCHARGE FROM A CONDENSER . . . . .	645
CONTACT BREAKERS OR INTERRUPTERS FOR BATTERY INDUCTION COILS . . . . .	648
THE ELECTRIC SPARK IN AIR . . . . .	658
THE DISCHARGE IN PARTIAL AND HIGH VACUA . . . . .	671
THE BRUSH DISCHARGE IN AIR . . . . .	701
THE CONDUCTION OF ELECTRICITY THROUGH GASES . . . . .	704
RADIO-ACTIVITY . . . . .	706

## CHAPTER XIX

## ELECTRICAL MEASUREMENTS

MEASUREMENT OF SMALL CONTINUOUS CURRENTS . . . . .	712
STANDARD CURRENT MEASURERS . . . . .	729
MEASUREMENT OF RESISTANCE . . . . .	736
RESISTANCES OF MATERIALS . . . . .	750
MEASUREMENT OF CAPACITY . . . . .	757

## CHAPTER XX

## ALTERNATE CURRENT MEASUREMENTS

ELEMENTARY PRINCIPLES . . . . .	763
CURRENT MEASUREMENT . . . . .	767
PRESSURE MEASUREMENT . . . . .	768
WAVE FORM . . . . .	772
MEASUREMENT OF INDUCTANCE . . . . .	784
MEASUREMENT OF CAPACITY . . . . .	797
MEASUREMENT OF POWER . . . . .	799
MEASUREMENT OF ENERGY . . . . .	807
MEASUREMENT OF POWER-FACTOR . . . . .	809
MAGNETIC MEASUREMENTS . . . . .	812
INDEX . . . . .	813

10

MEMORANDUM

TO : THE PRESIDENT

FROM : THE SECRETARY OF STATE

SUBJECT: [Illegible]

[Illegible]

[Illegible]

[Illegible]

[Illegible]

[Illegible]

[Illegible]

[Illegible]

[Illegible]

[Illegible]

[Illegible]

[Illegible]

[Illegible]

[Illegible]

[Illegible]

[Illegible]

[Illegible]

[Illegible]

[Illegible]

[Illegible]

[Illegible]

[Illegible]

[Illegible]

[Illegible]

[Illegible]

[Illegible]

[Illegible]

# ELECTRICITY

## IN THE SERVICE OF MAN

### PART I

## The History and Principles of Electrical Science

### INTRODUCTION

#### *EARLY HISTORY*

**A**LTHOUGH the applications to the service of man of electricity in all its varied branches only date from comparatively recent times, yet the early glimmerings, though scarcely the foundations, of the science can boast a respectable antiquity. Thus, whilst the first western practical application of magnetism of which there is any record is a somewhat doubtful reference to the use of the mariner's compass in the twelfth century, the properties of the lodestone had been known to the curious amongst the nations of the West since before the commencement of the Christian Era. It is true that the Chinese claim to have used magnetic needles on land journeys long before the outer barbarians were acquainted with them, but the web of Chinese chronology is too tangled to admit of a very precise date being assigned to this invention of a denizen of the celestial empire.

The direct practical application of the purely electrical side of the science is considerably more recent than the first magnetic application. It is probably to be found in the use of lightning conductors following upon the researches of Franklin in the eighteenth century. But the first electrical experiment is supposed to have been made six centuries before the Christian Era, thus giving a period of germination and growth to fruition of well over two thousand years, during which the services of this wonderful agent were lost to mankind. In the short period that



has elapsed since Franklin's days, and especially during the last fifty years, the rate of development has been marvellously accelerated, and there is, at present, no reason to suppose but that it will be as great, probably greater, during the present century.

It was not until the nineteenth century had well advanced that the firm connecting links between the sciences of electricity and of magnetism were discovered, and thus in their early developments these sciences were distinct and separate. In dealing with their early history, therefore, it will be most convenient to treat them separately for a time, though this separation must tend to disappear as the subject develops.

**Early and Classical References to Magnetism.**—The ancients were acquainted with the natural lodestone, although we cannot determine the exact date when it was discovered. They had, however, very exaggerated notions of its powers. According to Pliny, the lodestone was first found by a shepherd named Magnes, and hence the term magnet. Other historians refer to the lodestone under the name of "Lithos Herakleia," which meant Hercules stone, or the stone of Heraklea. The town of Heraklea, at a later period, received the name of Magnesia, which may have been the origin of the word magnet. Lucretius (born 95 B.C.) mentions the fact that the lodestone had the power of attracting and repelling iron.

Klaproth attributes the discovery of the magnetic needle to the Chinese, as early as the year 121 A.D. Another Chinese work, dating from the eleventh century, mentions the fact that sailors made use of the magnetic needle, and are said to have been acquainted with its variations. Magnetic needles were first employed by the Chinese on land journeys, and not sea voyages. The celebrated Tchi-nan-tschin had a magnetic needle, of which Poggendorff gives a description.

**Early History of Magnetism.**—Nothing certain is known about the exact period when the compass was brought to Europe. We find in a piece of poetry called "La Bible," composed by Guyot de Provins, dated 1190, some lines to the effect that sailors consulted the magnetic needle when bad weather set in. Jacques de Vitry, in his "Historia Naturalis" (1215-1220), mentions the magnetic needle as being at that time no longer a novelty.

The first European who took into account the declinations of the needle was probably Christopher Columbus. Its deflection from the due north had been previously attributed to the incorrect construction of the instrument. Variations in the deflection of the needle at the same place were first noticed by Henry Gellibrand in the year 1634.

In the year 1544 the discovery of the inclination, or dip, was made by Hartmann, who mentions the fact in a letter to Albrecht of Prussia. Robert Norman (1576), in making more accurate experiments to ascertain

the cause of "dip," found that iron, when magnetised, did not increase in weight, and that the action of the earth upon a magnetised needle free to move in any direction was simply *directive*, there being no resultant force of translation tending to drag the needle bodily. Very soon afterwards William Gilbert, physician to Queen Elizabeth, enriched the science of Magnetism with many new and interesting discoveries. So important were these that Poggendorff has called him the "Galileo of Magnetism." He was born at Colchester in 1540, studied at Oxford and Cambridge, and, after travelling for some time on the Continent, established himself as a physician in London, where he died in 1603. Considering the period at which Gilbert lived, his scientific knowledge must have been remarkable. It gained for him the favour of the queen, who gave him the means for carrying out his scientific experiments, and also appointed him her private physician. The principles and theories of Lord Bacon, who frequented Queen Elizabeth's Court, probably greatly influenced Gilbert. It is certain that he did not follow the plan, previously followed by the schoolmen, of making daring hypotheses to explain natural phenomena, but formed his ideas from direct experiment. This is exactly the plan advocated by Bacon.

Both Gilbert and Hartmann were aware that similar poles repelled each other. Gilbert observed, further, that pieces of iron vertically suspended became magnets, especially when the bar of iron had a similar inclination to that of the dipping needle, and that the poles of the magnets thus formed nearest the earth proved to be N. poles.

These and other new facts were published in his epoch-making book entitled "*De Magnete Magneticisque Corporibus et de Magno Magnete Tellure Physiologia Nova*," written in Latin and published in 1600. It has recently been translated into English by the Gilbert Club. Putting aside vain speculations and proceeding carefully by experiment, Gilbert sought an explanation for the then known facts of terrestrial magnetism which he had industriously collected. He found that he was able to reproduce roughly the known phenomena by means of magnetised spheres which he called "terrellas" or "earthkins." One of

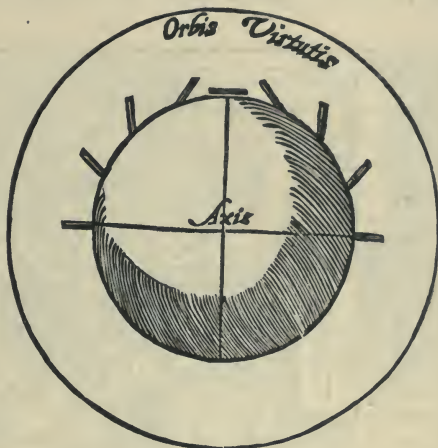

Fig. 1.—Gilbert's Terrella.

these is represented in Fig. 1, which is copied from Gilbert's book. As a result of his experiments he put forward the bold theory that the action of the compass could be explained by assuming that the earth itself is a huge magnet. In the figure the sphere represents the earth with its polar axis horizontal, and the little magnets shown on the surface approximately reproduce the phenomenon of the varying dip in different latitudes as it was known to Gilbert. Hudson, the discoverer of the bay bearing his name, practically proved Gilbert's theory by his journey into high northern latitudes in 1608, though the actual discovery of a north magnetic pole of the earth, at which the dipping needle

stands vertically, was not made until 1831. This magnetic pole does not coincide with the geographical pole.

Gilbert also found that a bar of iron held in the direction of the compass needle—or, better still, in the direction of the dipping needle—could be magnetised by hammering. The quaint wood-cut (Fig. 2), also reproduced from Gilbert's



Fig. 2.—Magnetisation by the Earth.

above-named book, illustrates one of his methods of making the experiment. The blacksmith is engaged in hammering a piece of cooling iron on the anvil, and whilst doing so holds it in the meridian (as shown by the words "auster" (south) on the door, and "septentrio" (north) on the wall of the smithy fire. Gilbert had found that a cooling bar of iron so held might become magnetised even though not hammered, but that the hammering greatly increased the effect. He also discovered that a magnetised bar of iron lost its magnetism when heated to a red heat. The history of magnetism subsequent to Gilbert will be resumed later.

**Early History of Electricity.**—It is difficult to give the exact date at which the first observations of electrical phenomena were made. Thales, one of the seven sages in Greece, who was born at Miletus in the year 640 B.C., and who died in 548 B.C., is supposed to have been



the first who observed that rubbed amber had the power of attracting small bodies. Amber was known to the Greeks by the name "elektron," and from this name the word "electricity" was derived. The ancients must have been acquainted with the effects of atmospheric electricity, as thunderstorms in most southern latitudes are of frequent occurrence, and they also knew of the St. Elmo's fire. They could, however, have had but little or no knowledge of electricity, and the few phenomena above noticed, with which they were acquainted, they were quite unable to explain, because, neglecting experiment as beneath the dignity of true philosophers, they confined themselves to all kinds of fantastic hypotheses.

**Gilbert's Discoveries.**—The science of electricity remained in this condition for nearly two thousand years, until Queen Elizabeth's physician, William Gilbert, made a series of fresh discoveries of electrical phenomena, which won him the title of founder of the science. He discovered that other bodies besides amber could be electrified by friction. Such bodies he called "electrics." They included several precious stones (diamond, sapphire, carbuncle, opal, etc.), rock-crystal, glass, sulphur, gum-mastic, lac, sealing-wax, hard resin, arsenic, rock-salt, mica, and alum. He was, however, unable to find that the following bodies were excited by friction, viz., emerald, agate, cornelian, pearls, jasper, chalcedony, alabaster, porphyry, coral, marble, Lydian stone, flints, hæmatites, corundum, bones, ivory, hard woods, metals, and lodestones. He also ascertained that the production of electricity was affected by moisture; that hot or burning bodies lost all electricity; and that an electrified body attracts a variety of other bodies, whereas a magnet only attracts steel or iron. The latter fact shows that he was acquainted with the difference between electrical and magnetic actions.

The Jesuit Nicolo Cabeo, Francastro, Descartes, and others studied electricity, but were satisfied to establish learned theories without testing them by actual experiments.

**Guericke and Boyle.**—The next scientist who increased the list of important electrical discoveries was Otto von Guericke. He was born at Magdeburg in 1602, studied law at Leipzig and Jena, and mathematics and mechanics at Leyden. After visiting France and England, and being employed as an engineer at Erfurt, he returned to Magdeburg, where he was elected mayor, and where he afterwards made his experiments. In 1681 he removed to Hamburg, where he died five years later (1686). Up to this time electrification had been produced by taking larger or smaller pieces of various substances in one hand, and rubbing them with a piece of another substance held in the other, the amount thus obtained being very small indeed. Guericke now, however, to his discoveries added the invention of an electric machine. Having cast a globe of sulphur, he supplied it with a wooden axle, and then mounted

the whole on a frame (Fig. 3), the hand being employed as the rubber. Although the arrangement was a very simple one, he obtained better results with it than any of his predecessors. By means of it he discovered that the production of electricity in large quantities was accompanied by light and sound. He further found that the electrified sulphur globe attracted light bodies, which it afterwards repelled until they had touched some other body. He also made the important discovery that a light body suspended near an electrified body, but not touching it, exhibits electrical properties. Contemporaneously Robert Boyle, the discoverer of Boyle's Law in Physics and the inventor of the air-pump, very much

extended the list of known electrics, and discovered that electrical attractions can take place in a vacuum.

**Discovery of Electrical Luminosity.**—About the same time Picard observed the luminosity of greatly rarefied gases. Experimenting with an imperfectly exhausted barometer tube, he agitated the mercury in the tube, thus producing electrifications which caused the mercury vapour and the remaining air to glow.

Hawksbee, who lived at the commencement of the eighteenth century, gave the first proper explanation of Picard's observations. He experimented in the following manner:—Taking several glass vessels containing mercury, he exhausted the air by means of an air-pump, and then agitated the mercury.

The glow which was thus produced inside the vessels he attributed to electricity, and to test the point he was led to construct an electrical machine. He substituted for the sulphur ball of Guericke a glass globe, which he exhausted, and thus, besides the glow, obtained sparks an inch long. He also experimented with other substances, such as sealing-wax, etc., from which he discovered that the electricity of these bodies was not of the same character, though he did not go so far as to recognise the positive and negative electrifications.

Stephen Gray (1696–1736), a Fellow of the Royal Society, about whom little is known, was the first to draw attention to the classes of conducting and non-conducting bodies. Experimenting with some glass tubing, the ends of which he closed with corks, he found that although the corks were not rubbed, they attracted and repelled small bodies exactly like the excited glass tube. He followed this discovery up, and found out

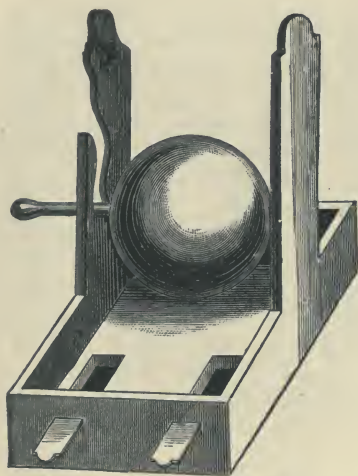

Fig. 3.—Guericke's Sulphur Ball.



the difference between conductors and non-conductors, or insulators. He also ascertained that the distribution of electricity on a body was unaffected by the mass of that body.

**Discovery of two kinds of Electrification.**—Charles François de Cisternay du Fay, better known under the simple title of Du Fay, made experiments during the years 1733-1739. He found, as the result of his investigations, that electrified bodies attract all unelectrified bodies, electrifying them in turn, and then repelling them; also that there are two distinct kinds of electrification—namely, that which is produced by rubbing glass, etc., and that which is produced by rubbing amber, resin, sealing-wax, etc. He termed the former kind vitreous electricity, and the latter resinous electricity, and showed that bodies electrified with vitreous electricity repelled one another but attracted bodies electrified with resinous electricity; these latter in their turn repelled one another. His experiments on living bodies produced a great sensation at the time.

**The Globe Electric Machine.**—It is a curious fact that these men were content to produce the required electricity by means of a rubbed glass rod, and none of them thought of perfecting Guericke's and Hawksbee's electrical machines. Litzendorf, a pupil of the mathematical Professor, Christian August Hansen, proposed to use in the place of the glass rod a glass ball, which might be rotated by means of a wheel. The professor carried out the suggestion, and thus a ball was employed a second time, but the hand was still retained as the rubber.

**The Prime Conductor.**—Professor George Mathias Bose, who died in 1761, constructed the first prime conductor, which was simply an iron tube, held by a person who stood on a cake of resin. This method of supporting the conductor he soon found to be inconvenient, and he therefore suspended it by silk threads. Observing that the person rubbing the glass ball became charged with electricity as well as the conductor, he put a kind of armour all over the person and let him stand on a large cake of resin. When charged the person began to glow all over, the effect terminating with a kind of halo round his head. This experiment was known under the title of the "beatification." Bose also succeeded in firing gunpowder with an electric spark.

**Cylindrical and Plate Machines.**—Professor Andreas Gordon, of Erfurt, a Scottish monk, changed the glass globe for a glass cylinder; and Giessing, under the direction of Professor Johann Winkler, of Leipzig, constructed a cushion, or rubber, which consisted of some woollen material held in position by metal catch springs. The electrical machine now possessed both rubber and prime conductor. Benjamin Wilson (1746) improved the prime conductor by adding a series of points, which he termed the collector; and Canton (1762) improved the rubber by the

addition of amalgam of tin. With the machine as thus improved very fair results were obtained.

Several claim to have been the first to use a glass plate instead of a glass cylinder, but Poggendorff says that Planta was the first who made use of the plate machine. Several machines with very large plates were constructed; the Duke de Chaulnes made a machine the plate of which had a diameter of nearly five feet; this machine gave sparks of twenty-two inches in length.

**The Electric or Leyden Jar.**—We come now to the discovery of the electric jar. According to our authority, Poggendorff, Dean Kleist was the inventor of the electric jar. In 1745 Kleist brought near his electrical machine a medicine-bottle, in the neck of which there happened to be an iron nail. Holding the bottle with one hand, the other happened to touch the nail, and, to his surprise, he received a violent shock; he made several experiments to trace the cause, and communicated with several people regarding them.

About the same time Pieter van Musschenbroek made the same discovery. Musschenbroek, Professor at Leyden, observed that electrified bodies lose their electricity when exposed to the atmosphere. To prevent the electricity from leaving some water, he put the water into a glass bottle, and conducted the electricity along an iron nail. Cuneus, at Leyden, who worked with Musschenbroek, happened to hold this bottle in one hand in order to charge it, and on removing the bottle from the conductor he touched the conducting wire with the other hand; he then received a shock like Kleist. Musschenbroek repeated the experiment, but got so frightened that he wrote to Réaumur: "not for the imperial crown of France would he expose himself a second time." Réaumur mentioned the fact to the Abbot Rollet in Paris, and he it was who introduced the term Leyden jar. Winkler, Grabath, Le Monnier, Bevies, but especially Winkler in Leipzig, worked at the subject. Dr. Bevies conceived the happy thought of covering the outside of the jar with tinfoil. After some time he tried to charge a glass plate covered on both sides, and received when discharging it a violent shock. This caused Sir William Watson to construct for the first time a perfect Kleist, or Leyden jar. Watson covered earthenware vessels with tinfoil almost up to their edges; he knew that the efficiency of the jar depended on the surface of tinfoil, but about its mode of action he had no exact ideas.

**Franklin's Discoveries.**—Benjamin Franklin explained this action, and made important discoveries regarding the Leyden jar. He found that an insulated ball, after contact with the inner coating of the jar, was repelled by the outer coating, and *vice versa*. He suspended a cork ball, which received its charge from the outer coating, and found it to be repelled by a wire in connection with the inner coating; he further made wires from the outer and inner coating come within an inch or

so of each other. Between these wires he suspended the cork ball, which oscillated until the jar had lost all its electricity. On the basis of these experiments Franklin tried to explain the behaviour of the Leyden jar. At the same time he laid down a law of electricity, that when two oppositely charged conductors, separated by an insulator, are brought near together they will attract each other. Franklin, one of America's greatest citizens, was born in 1706. On his statue is the appropriate epitaph, "He snatched the lightning from heaven, and the sceptre from tyrants." His crowning invention was the lightning conductor. He thought lightning to be nothing more than an enormous electrical spark, though he was not the first to entertain this idea; we know that Wall, Rollet, and Winkler, in particular, reasoned in the same manner; but he was the first to give clear and distinct explanations, and to propose experiments to prove them. Franklin was, however, forestalled in the experiment which he proposed; the first who actually made the experiment were the Frenchmen, Dalibrand and Delor.

Franklin, for the purpose of verifying his theories, commenced experiments (1752), which enabled him to give directions for the practical construction of lightning conductors. The best known of these experiments are those in which he used kites for the purpose of establishing electrical connection with thunder-clouds and the upper layers of the atmosphere. Franklin's kite was made of silk, so that it should not be damaged by rain, and had a sharp pointed wire fixed as a collector on the top. On the approach of a thunderstorm he flew his kite in the ordinary way, and with ordinary twine for string; an iron key was hung at the end of the twine, to which also was tied a length of silk ribbon, which acted as an insulator, and was kept dry by being brought under the cover of an open shed. When the twine became sufficiently conductive by being wetted by the rain, sparks were drawn from the key, and all the usual known experiments of the laboratory were made, the key behaving like the prime conductor of an electrical machine. In this way the identity of lightning with the electric spark of the laboratory was established. As regards lightning conductors Franklin reasoned thus:—Knowing that lightning and the sparks produced with the electrical machine were identical, he thought if it were possible to conduct electricity from the clouds, it would be equally possible to rob it of its destructive power. A spark being only produced along a conductor that has a break in it, or which is too weak in itself to render this electrical spark harmless, it would only be necessary to use metal rods of sufficient strength or conductivity, and to have them well connected with the earth. Winkler, in Germany (1753), warmly urged the erection of lightning conductors. Through his influence a clergyman had the first lightning conductor erected near his house. Unfortunately the summer of 1756 was very



dry, and the superstitious peasantry ascribed it to this lightning rod, and were not satisfied until they saw it removed.

**Richmann's Death.**—Professor Richmann, at St. Petersburg, had in his room an insulated iron rod erected for the purpose of studying atmospheric electricity. During a thunderstorm in August, 1753, Richmann approached to observe his rod, when a large spark or ball of fire rushed from it and killed him on the spot. His engineer, Sokoloff, who was present at the time, was thrown to the ground, but recovered after a short time. De Romas, in France, experimented on atmospheric electricity, but with greater care. Like Franklin, he used a kite of large dimensions. The line by which he held this electrical kite had wire twisted round it, and terminated in a rope of silk; to the extremity of the wire rope he attached a cylinder of sheet-iron. With this apparatus he obtained remarkable results. In August, 1757, by using a similar discharger, he obtained sparks ten feet long. The sad fate of Richmann caused a great sensation, but did not prevent men like Le Monnier, Beccaria, and Cavallo from continuing their experiments.

**Electrometers.**—The use of electricity in medicine was brought forward, and ways of measuring electricity were diligently tried. The first electrometer was constructed by John Canton (who lived from 1718 to 1772 in England); it was the well-known pith-ball electrometer. Several others constructed electrometers in principle like Canton's. The mathematical theory of their action, however, was not clearly understood, and therefore exact quantitative results were not obtained. In fact, although dignified with the name electrometers, they were little more than electroscopes.

Repulsion between two pith-balls was observed when a charged body was brought near them; this phenomenon was studied and explained by *Æpinus* and *Wilke*. They further considered that they had proved that one of Franklin's notions about the *Leyden jar* was incorrect, namely, that in which he attributed the behaviour of the jar to the peculiar structure of the glass.

**Symmer's Theory.**—The science of electricity was advanced not a little during the period of silk stockings. Robert Symmer (1759) used to wear silk stockings, and always two pairs at a time, one white and the other black; whenever he pulled one pair from the other he heard a crackling noise, which he attributed to electricity; he found also that stockings of the same colour repelled each other, and those of different colours attracted each other. Although these facts proved nothing new, Symmer was led to take up again *Du Fay's* theory, that there are two different kinds of electricity. To prove this theory Symmer sent a spark through paper and examined the perforation. The edges of the hole which the spark had made were turned up on both sides of the paper. According to Franklin's theory, this fact could not very well be explained:

Symmer explained it by assuming that "in an electric discharge two streams of electricity flow in opposite directions." Although he could only propose this one experiment to maintain his theory, electricians considered it conclusive. Franklin was kind enough to send Symmer an apparatus which he thought might aid him in establishing his theory, though opposed to his own. Symmer's, or rather Du Fay's theory, received further support by Lichtenberg's discovery of electrical dust figures in 1777. These dust figures assume different shapes when first produced by positive, and then by negative electricity, and *vice versâ*. Lichtenberg also introduced the terms  $+$  and  $-$ , which, however, had been previously proposed by Sir William Watson.

The charging of coated insulators and the improvement of measuring instruments now received attention. Volta constructed the electrophorus, which led him on to the discovery of the condenser, an instrument so called because it was supposed to condense electricity. Its action is precisely similar to that of the Leyden jar. Volta, in 1781, also devised the straw electroscope. Both Bennet and Volta suggested the use of the condenser and the electroscope combined.

**Cavendish and Coulomb.**—Exact quantitative work in electricity received a great impetus by the researches of Cavendish in England and of Coulomb on the Continent. Many of Cavendish's brilliant researches were lost to his contemporaries by his neglect to publish them. He, however, published in 1771 important contributions to electrical theory, amongst them being an ingenious null method by which the law of inverse squares was proved to a high degree of accuracy. He also was the first to make quantitative measurements on electrical resistance. One of his experiments gave the specific resistance of water as 400,000,000 times the resistance of iron. Charles Augustine de Coulomb (born in June, 1736) published in 1784 the results of his celebrated researches on the force of torsion and elasticity of metal wires. He constructed shortly afterwards the torsion-balance, an instrument still in use, and which will be more fully referred to in due course. After Coulomb's researches, nothing was added to the knowledge of statical electricity for a considerable time.

**Animal Electricity.**—Some electrical phenomena in the animal kingdom were simultaneously receiving attention. Réaumur (about 1714) pointed out that the electrical shad-fish was capable of imparting violent shocks. These he attributed to the muscular power of the animal's tail. It was afterwards assumed that these shocks might be of an electrical nature, and this was proved experimentally by Dr. John Walsh in 1772. He experimented on the electrical shad-fish, and showed that in order to obtain the shock the fish must be touched on both sides at the same time. Many experiments in different directions were made to solve the problem as to the source of the electricity of the torpedo



and electric eel, but even up to the present time much uncertainty prevails.

**Galvani and Volta.**—Luigi Aloisio Galvani (born 1737) made some important discoveries through noticing the motions of a frog's leg. When published, his experiments and explanations were much talked of, and a scientific war commenced between Galvani's and Volta's followers. Alessandro Volta was born 1745, and first published the results of his researches between 1769 and 1771; this brought his name before the public. Poverty and disease prevented Galvani from following up his discoveries. Volta made experiment after experiment, which ultimately resulted in the discovery of the pile. In 1800 he informed the Royal Institution, London, of his invention. The value of Galvani's and Volta's discoveries will be best understood in following the further growth of that particular branch of electrical science in which the electric current plays such an important part. Volta and Galvani no doubt laid the foundation, but to complete the structure required such men as Oersted, Ampère, and Faraday.

**Oersted's Discovery.**—It has been said that an apple falling to the ground caused the discovery of the law of gravitation; the motion of a frog's leg led to the discovery of methods of generating a steady electric current; chance led Oersted to observe the influence an electric current has on the magnetic needle. Are all these discoveries to be attributed to chance only? And how is it to be explained that these so-called chances only happen with great men? Whewell says, in his "History of Inductive Science," "These accidents, if accidents at all, are more like the spark that sends the charge of a gun to a directed aim." The fact is that it is the man who has been trained to use his eyes and to observe all that is passing before him, whose mind is alert to any variation in the results which he is expecting—in short, it is the man who can *see* to whom such discoveries fall. They are not accidents or, in any but a remote degree, the results of chance. Many apples had fallen to the ground before Newton's time, and doubtless magnetic needles had been deflected by electric currents before Oersted noted, and realised the significance of, the effect.

Hans Christian Oersted was born 1777; his most important discovery was that of electro-magnetism (1819). Oersted's discovery explains the magnetisation of iron rods through which lightning has passed, and also explains the polarisation of magnetic needles. Ampère took great interest in Oersted's discoveries, and through them was finally led to his celebrated theory of electro-dynamics. Ampère's theory was not so readily accepted by his contemporaries as might have been expected. In 1822 Schweigger constructed a galvanometer, and Professor Seebeck discovered thermo-electricity. George Simon Ohm, born 1787, laid down a law (1827) for electric circuits, and Arago (1824) published the results of his researches on the magnetism of rotation.

Properly speaking, the early history of electricity comes to a close here; all these discoveries are part of the modern development of electricity, and the science of electricity commences with them and the results of the researches of Davy and Faraday. The one who, as it were, prepared the ground was Sir Humphry Davy (born 1778). His researches regarding the influence of the electric current on chemical compounds were begun in 1806, and led him to the decomposition of the alkaline earths and the discovery of the alkaline metals. Chlorine was found to be an element, and the products of decomposed bodies to have electro-positive and electro-negative properties. This observation led to the electro-chemical theory. Although water was decomposed by Carlisle and Nicholson in 1800, no proper explanation of the result could be furnished until Davy proved water to consist of oxygen and hydrogen only.

We owe to Faraday, his pupil, the further working out of Davy's notions. Michael Faraday (born 1791) was no doubt one of the greatest physicists that ever lived. We need not go into the details of his discoveries in many other branches of science. For us, his name is chiefly associated with the laws of electro-statics and magneto-electric induction. The enormous importance of his discovery of induction may easily be seen by pointing to the present condition of electro-technics, *i.e.* to the telegraph, telephone, and dynamo machine.

## CHAPTER I.

## PRINCIPLES OF MAGNETISM.

## I.—ELEMENTARY FUNDAMENTAL PHENOMENA.

**The Lodestone.**—There is a certain ore in nature termed by mineralogists magnetite, and having the chemical composition denoted by the formula  $\text{Fe}_3\text{O}_4$ , which possesses certain remarkable properties. If we take a piece



Fig. 4.—Attraction of Iron by a Magnet.

of this ore which has been shaped a little, and plunge it into iron filings, fringes of the filings adhere to it in two places. If we suspend it, so that it can turn freely, as by placing it in a chair or saddle of paper hung by a fine torsionless thread, or by floating it on cork, it sets itself with these places, pointing nearly north and south. All these properties we imply when we call it a lodestone, or natural magnet. If we draw the part of the lodestone where the filings adhere

three or four times along a small sewing-needle, it communicates its properties to the needle. The lodestone gives the needle some power it had not before. We describe what we have done to the needle by saying we have magnetised it, or have imparted magnetism to it. Hence we have *natural* magnets like the lodestone, and *artificial* magnets like the sewing-needle. In what follows we shall employ, in the place of our irregularly-shaped natural magnet, a regular bar of steel, made a magnet by being drawn across another magnet, or by one of the electrical methods to be subsequently described. An artificial magnet, such as this bar magnet, possesses the same three properties as the lodestone: 1. It attracts iron. 2. When freely suspended, it sets in a particular direction. 3. When we draw it along a piece of steel, it makes the steel a magnet.



**The Poles of a Magnet.**—Some simple experiments will help us to examine more clearly these magnetic phenomena. Fig. 4 represents an iron ball suspended by a silk thread from a wooden stand. If we bring a magnet near this iron ball the iron ball is attracted by it, and held in contact. If we substitute other substances, as stone or brass, for the iron, the magnet exercises no power over them. If we now suspend the magnet in the same way, and bring a piece of iron near it, the magnet moves towards the piece of iron. From these experiments we conclude that the iron and the magnet attract each other, but that the magnet is not influenced by other substances. If we now bring



Fig. 5.—Iron Filings adhering to Bar Magnet.

our iron ball near different parts of the magnet, we soon observe that the two ends of the magnet influence the iron ball at a considerable distance, whilst the centre of the magnet has no power over the ball. The magnetism is thus not evenly distributed over the bar. The distribution of the attracting force along the magnet is roughly shown by plunging the magnet in iron filings, when they adhere to it in the manner shown in Fig. 5. The fringe of iron filings is thickest at the ends of the magnet, while in the centre there are none. The extremities of the magnet are termed its *poles*; the central space where no filings are found is termed the neutral zone.

**Declination.**—We further observe that our suspended magnet, or, better still, a magnetised knitting-needle, as shown in Fig. 6, takes up a definite position relatively to the earth, the direction being approximately north and south. The pole pointing towards the north pole of the earth we term the north-seeking pole, and that pointing to the south we term the south-seeking pole. Exact measurements, however, have shown this direction *not* to be *exactly* north and south; and the angle contained by the magnetic needle and the true meridian is called the *declination* or *variation*, the line in which the needle lies being known as the *magnetic meridian*. Thus the declination or variation is the angle contained between the geographical and the magnetic meridians.

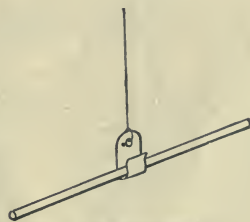

Fig. 6.—Suspended Magnetic Needle.

The term *declination* is usually employed by landmen and for scientific purposes, but mariners use the term *variation*. The reason is that one of the angular co-ordinates of the celestial bodies is called the declination, and to avoid the remotest chance of any error, by which human lives might be

lost, it has been agreed that in nautical literature the word *declination* shall be restricted to this use and that the magnetic declination shall always be referred to as the *variation* of the compass.

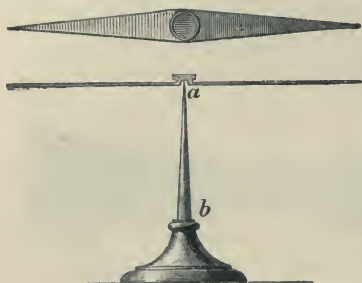

Fig. 7.—Magnetic Needle.

**Inclination, or Dip.**—Take a piece of unmagnetised knitting-needle steel and balance it carefully so that it lies horizontally on a pivot or at the end of a torsionless thread. Now dismount it, magnetise it, and restore it to its former position. It will be found that the pivoted or suspended magnetised needle does not remain horizontal, but that it is quite out of balance, and that one end dips downward; the angle which the axis of the needle makes with the horizontal plane is known as the *dip*, or

*inclination*. In our latitudes the north-seeking pole points downward.

Declination and inclination vary with time and place. The declination for Europe, Africa, and the Atlantic Ocean is west; that is, the north-seeking pole of the needle points west of true north. The declination for America and Eastern Asia is east. In the northern hemisphere the north-seeking pole points downward; in the southern, the south-seeking pole points down. Fuller particulars of these variations will be given in the section on *Terrestrial Magnetism* (see page 37).

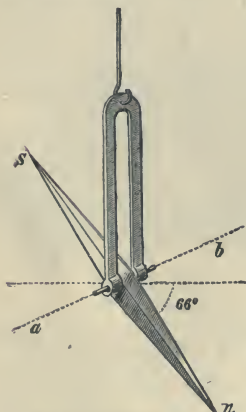

Fig. 8.—Inclination Needle.

**Magnetic Needles.**—The form of a magnetic needle arranged to show the magnetic meridian is represented in Fig. 7, where the needle moves upon a perpendicular axis or pivot *a b*. A dipping needle arranged to show the inclination is shown in Fig. 8, where the needle *s n* turns upon the horizontal axis *a b*. When used it must be set so that the plane in which the needle swings contains the magnetic meridian, as indicated by a horizontally moving needle. Fig. 9 represents a simple compass. It consists of a

magnetic needle resting on a steel pivot, protected by a brass case covered with glass, and a graduated circle marked with the letters N, E, W, S, to indicate the cardinal points; *a b* is a lever which arrests the needle by pushing it against the button *d* is pressed. The mariner's compass, the principle of which is shown in Fig. 10, is more complicated; it consists of a card pivoted at *c* on a vertical axis, and directed by having on its lower surface two or more parallel magnets. The upper



surface of the card is divided into degrees, and also into thirty-two parts of  $11\frac{1}{4}^\circ$  each. The pivot on which *c* rests rises from the bottom of a bowl *B*, heavily weighted with lead, and mounted on "gimbals," so as to remain horizontal whatever the position of the ship. These gimbals consist of two short axes *x x*, opposite one another, which work in bearings in the flat ring *R R*, which in its turn is carried by axes *y y*, placed at the ends of a diameter at right angles to *x x*, and working in bearings in the outer case. As a consequence of this mounting, in whatever way the outer case be tilted the upper surface of the bowl remains horizontal. The presence of any iron or steel in the neighbourhood of the compass alters the direction of the magnetic force, and causes what is termed a *deviation* of the north and south line from the magnetic meridian.

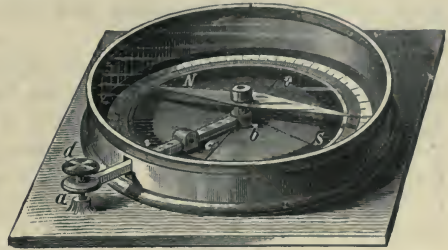

Fig. 9.—Simple Compass.

**Mutual Action of Magnets.**—It has been said that a magnet possesses the power of attracting iron, the force with which it does this being strongest nearest the poles, and diminishing towards the middle until it becomes zero. There is no difference between the poles of a magnet in this respect, but there is a further action between magnets, which we now proceed to describe.

Having marked the north-seeking end of two magnets, let us suspend one of them as in Fig. 6. If we bring a piece of soft iron first to one end and then to the other, we find that it is attracted at both. Now take up the other magnet, and present its marked end to the marked pole of the suspended magnet. The resulting action is not attraction, but repulsion. If we turn the unmarked end to the unmarked end, the one repels the other, as before. If we next bring the marked end of one to the unmarked end of the other, we get attraction and not repulsion.

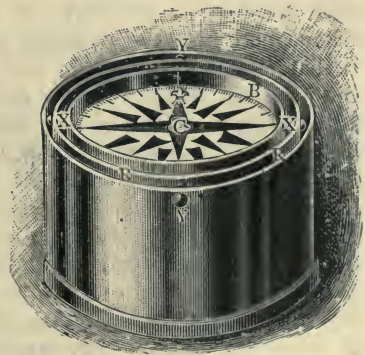

Fig. 10.—Mariner's Compass.

Hence, there is a difference in the actions on a suspended magnet of a non-magnetised piece of iron and of another magnet. The non-

magnetised piece of iron attracts both poles, but the action between two magnets is not quite so simple. Between magnets *similar* poles *repel*, but *dissimilar* poles *attract*; thus the north-seeking end repels the north-seeking end, the south-seeking end repels the south-seeking end, while the north-seeking end attracts the south-seeking end, and *vice versa*.

These experiments enable us to draw a distinction between *magnetic bodies* and *magnets*, and to examine the magnetic condition of a piece of iron. First present the north-seeking pole of a magnet to the piece of iron, and then the south-seeking pole. If both poles attract the same end of the iron, the latter is not a magnet, but only a magnetic body. If, however, it repels one of the ends and attracts the other, it is a magnet, and will be found to have at least one north-seeking and one south-seeking pole. The experiment, though simple, requires to be made carefully.

**The Earth a Magnet.**—The difference between the poles accounts for the fact that when a magnet is free to move it invariably takes the position pointing north and south. Since magnets at most parts of the earth tend to take up this position, it follows, as first shown by Gilbert (*see* page 4), that the earth itself must possess a distinct magnetic north pole and a magnetic south pole. We shall refer later on (page 42) to the actual positions of these magnetic poles, but we here encounter a difficulty; it follows from what we have stated that the magnetism of the magnetic north pole must be opposite in character to that of the north-seeking end of the magnet, and similar to that of the south-seeking end. In what terms, then, are we to distinguish between these opposite kinds of magnetism? We cannot at the same time call both the north-seeking pole of a magnet and the pole of the earth to which it points north poles, for the poles which attract each other are dissimilar. There are various methods of getting over this difficulty, but as they always lead to some complication or confusion, we shall merely refer to the ends of the magnet as north- and south-seeking ends, and ask the student to bear in mind that the north magnetic pole of the earth and the north-seeking pole of a magnet have magnetic properties of opposite character—they are dissimilar poles.

**Magnetic Induction.**—If we vary one of the foregoing experiments and examine the condition of a piece of soft iron held close to a magnet, we find that the soft iron is not only attracted, but becomes a magnet itself, capable of attracting another piece, which again might attract a third piece of iron, and so on; only the magnetic effect in each succeeding piece is less than that in the preceding one. Thus, in Fig. 11, if *N S* is a steel magnet and *A* a bar of soft iron held near it, then a string of iron nails can be suspended from the end of *A* whilst *N S* is in position. On the magnet *N S* being withdrawn, all

these pieces of iron become detached from each other, showing that they were only magnetised when the first piece was close to the magnet. Again, if we suspend an iron bar over a surface covered with iron filings, the filings and iron bar have no action upon each other; but if we now suspend a magnet over the iron bar the filings are attracted by the iron bar even when it does not touch the magnet. This effect is not lessened by placing between bar and magnet a sheet of glass, wood, or pasteboard. The filings, however, fall from the bar immediately on the magnet being withdrawn. If we want to ascertain the magnetic condition of the bar of iron whilst the magnet is near it, we can do so by means of a declination needle, and we find that the pole, *n*, nearest the south-seeking pole, *s*, of the magnet is a north-seeking pole, and the other pole, *s*, a south-seeking pole.

From this we infer that the bar of iron has become a magnet for the time being, without actually being touched by the magnet. During all these experiments the original magnet may be observed to have lost nothing of its power. It is neither weakened by being used

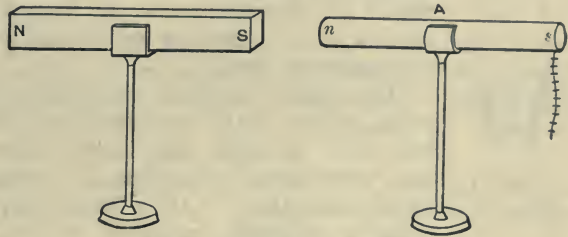

Fig. 11.—Iron Rod under Induction.

to magnetise a piece of steel, nor by acting inductively on soft iron. When pieces of iron are brought near a magnet, the magnetism of the magnet does not flow over to the piece of iron, but the latter is said to become a magnet by *induction*. The vertical bars of iron railings often become magnetised in our latitudes, the lower ends being north-seeking poles and the upper ends south-seeking poles. The earth thus acts as any other magnet, and its magnetism in the northern hemisphere causes the lower ends of the railings to exhibit north-seeking magnetic properties, whilst south-seeking magnetic properties are exhibited at their upper ends. An additional and strong experimental proof is thus given of the truth of Gilbert's theory that the earth is a magnet.

Another illustration of magnetic induction is given by the following experiment.

If two pieces of soft iron, *A* and *B*, in Fig. 12, are suspended by means of silk threads, on the north-seeking pole of a magnet being brought near them they become magnetised, and in both we find the north-seeking pole farthest from the north-seeking pole of the magnet, and the south-seeking pole nearest the north-seeking pole of the magnet. Since



similar poles repel each other, it follows that the suspended pieces of iron diverge as shown in the figure.

It has been ascertained by experiment that when under the influence of a magnet a bar of soft iron readily becomes a magnet, but it becomes demagnetised as readily when the influencing magnet is removed. Unannealed iron and steel, on the other hand, do not become entirely demagnetised when the influencing magnet is removed. The magnet made of soft iron is termed a temporary magnet, and the steel magnet a permanent one. No ordinary piece of iron after once being magnetised loses all its magnetism, and no piece retains the maximum amount of induced magnetism. The magnetism which actually remains is called *residual magnetism*. The cause of this phenomenon appears to be some kind of molecular resistance which occurs among the particles of the iron, and this force, which opposes magnetisation or demagnetisation, is termed *coercive force*. The kind of iron or steel in which this force is greatest retains its magnetism best.

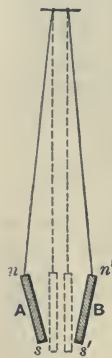

Fig. 12. — Repulsion due to Induction.

The details of these experiments and the many interesting results, both theoretical and practical, to which they lead will be dealt with later, when we have extended our experimental researches by considering the subject of electro-magnetism. As a direct application of the principles of magnetic induction, we shall next describe some of the old methods of magnetising steel magnets. These methods are to a great extent obsolete, having in many instances been replaced by electrical methods which are both more expeditious and more definite, but they are still occasionally of practical use, as, for example, in reversing the magnetism of a dipping needle in exact observations (page 47) on the dip.

**Methods of Making Magnets.**—*Single Touch.*—Place one pole of a magnet at the middle of the piece of steel to be magnetised, as shown in Fig. 13. Then draw the magnet from the middle towards the end of the piece of steel; repeat this several times, but take the magnet off at every stroke, and always draw the magnet from the middle towards the end of the piece of steel. In this case we obtain a south-seeking pole at the end of the bar at which the north-seeking pole of the magnet is drawn off, because at the moment of drawing off the magnetic induction is such as to produce this polarity. Next take the other pole of the magnet (in our case the south-seeking pole), and place it in the middle of the steel, and draw it along the bar in the opposite direction; we shall thus obtain a north-seeking pole at the other end. The magnet, during the operation, does not lose any of its magnetism, and it is a



matter of indifference which of the poles is taken first. The same result may be obtained in several other ways: for instance, by placing the dissimilar poles of two magnets on the steel and drawing them simultaneously from the middle towards the ends of the steel.

*Double or Divided Touch.*

—Arrange the bar of steel and magnets as shown in Fig. 14. The magnets make an angle of about  $20^\circ$  with the steel bar, and between them is a piece of wood, shaped as in the figure; now move magnets and wood from the middle

towards one end of the steel bar, then back again to the middle, and from the middle towards the other end of the bar and back again; repeat this until the bar seems to take up no more magnetism, then take off both magnets at the same time, but from the middle. A horseshoe magnet may be used instead of the bar magnets.

The bars of steel to be magnetised have been hitherto described as straight bars, but the methods can be applied, with obvious modifica-

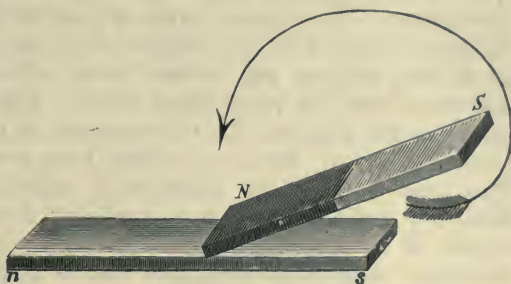

Fig. 13.—Single Touch.

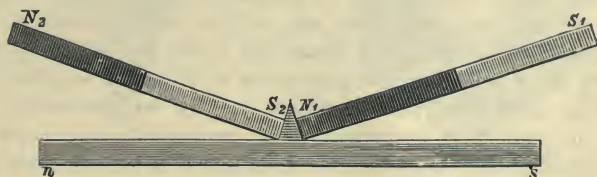

Fig. 14.—Divided Touch.

tions, to horseshoe-shaped pieces of steel, thus producing the well-known horseshoe magnets, some forms of which are shown in Figs. 16 and 17.

It should be noted here, and we shall dwell on the importance of the fact later, that properly magnetised magnets have always two poles. It is possible, by special or careless magnetisation, to produce magnets with *more* than two poles, but no process of magnetisation will produce a magnet with a single pole. If an abnormal magnet with more than two poles be dipped into iron filings the filings will adhere at places other than the two poles, as illustrated in Fig. 15.

If the polarities of these various places are examined they will be found to be alternately north- and south-seeking. Thus in the figure

the regions *N*, *B* and *N* have north-seeking polarity, whilst *A* and *C* have south-seeking polarity.

The chemical composition, hardness, and dimensions of the piece of steel to be magnetised ought to be taken into consideration in deciding the method to be adopted. After a piece of steel has received a certain number of strokes with a magnet of a certain power, it becomes a permanent magnet, and is said to be saturated. This, however, does not mean that the piece might not be magnetised further by using a more powerful magnet. But the magnetisation produced cannot be extended beyond a certain limit, no matter how powerful the magnet we use. This limit is called the maximum of saturation. The hardness of the steel, the manner in which it has been hardened, and the amount of carbon in it, influence the limit to which it can be magnetised. The magnetism is increased when the steel is rich in carbon, and when it is very hard. When the steel is without carbon its hardness greatly



Fig. 15.—Badly Magnetised Bar with Consequent Poles.

influences the result; when rich in carbon, this influence of its hardness is not so great. The tempering, etc., of the steel is also to be taken into consideration. Owing to these and other causes, it is impossible to lay down exact rules for the production of powerful magnets. According to Jamin, hard steel, rich in carbon, is best for permanent magnets. Cast iron is capable of receiving some permanent magnetism, but its maximum of saturation is not great, especially if it be subjected to rough usage or vibration.

Bars of steel often become magnetised by hammering, friction, etc. The magnetism in a piece of steel is weakened by heating the steel, entirely destroyed by heating the steel to bright redness, and somewhat increased by plunging the hot steel in cold water. Many of these and analogous effects were observed by Gilbert (page 4).

The magnetisation of a freshly magnetised steel magnet tends to grow gradually less as time goes on, especially if in the first instance the steel has been magnetised to the saturation limit. Such magnets may be rapidly brought to a steady state of magnetisation, or "aged," as it is called, by repeated heatings and coolings, provided the temperature to which they are heated is not excessive. For most practical purposes an upper limit a little above  $100^{\circ}$  C. is sufficient.

**Armatures.**—A piece of soft iron of suitable shape placed across the

poles of a magnet, so as to join or almost join them with magnetic material, is known as a keeper, or *armature*. It is obvious that soft iron in such a position will become well magnetised, and be strongly attracted by the magnet between whose poles it is placed.

**Lifting Power of a Magnet.**—The lifting power of a magnet may be ascertained by hanging weights from a properly fitting armature until the armature falls off, then the lifting power of the magnet is equal to the maximum weight held up. If the weights are gradually increased

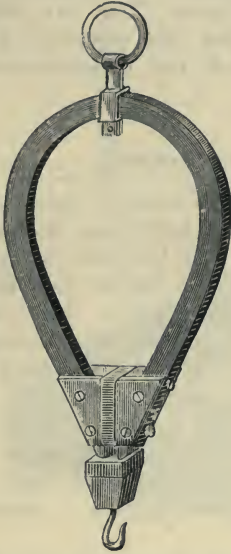

Fig. 16.—Jamin's Compound Magnet.

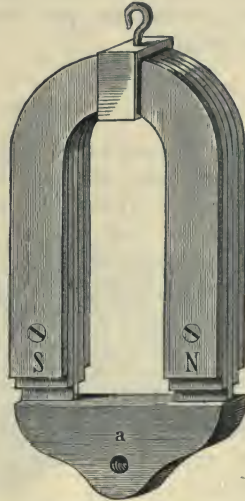

Fig. 17.—Magnetic Battery.

from day to day, the magnet will be found to bear a load much above that which it would have held if the load had been suddenly applied. Small magnets bear greater loads in proportion to their own weights than large ones; and, as a rule, the lifting power of horseshoe magnets is greater than that of an ordinary bar magnet. The lifting power is also increased by making the area of contact between the armature and the magnet greater. Long thin magnets are more powerful in proportion to their weights than thick ones, hence if any number of thin magnets are placed in a bundle we get a magnet considerably stronger than a solid one of the same weight, or than any of the component magnets. Its lifting power, however, is less than the sum of the lifting powers of the separate magnets. Thus, when Jamin placed six equal magnets each weighing three kilogrammes, and having a lifting power of 18 kilogrammes,



upon each other, the compound magnet had not a lifting power of six times eighteen, or 108 kilogrammes, but only of 64 kilogrammes. On taking it to pieces, each of the component magnets was then found to have only a lifting power of from 9 to 10 kilogrammes. Jamin, by arranging the magnets in this manner, produced the compound magnet (Fig. 16) which bears his name. It consists of steel bands, whose ends are kept in position by the brass cap shown in the figure. The compound magnet, or, as it is sometimes called, the magnetic battery, represented in Fig. 17, has the components arranged to diminish the influence which the poles of the steel bands have upon each other. They are made of unequal lengths, so that their poles do not fall together. The lifting power of electro magnets very much exceeds that of permanent magnets of the same weight.

## II.—MAGNETIC LAWS AND THEORY

The earlier discoveries in magnetism were made by means of experiments with permanent magnets, such as we have been dealing with in the last few pages. They also extended over the time when Newton's great discovery of the law of universal gravitation had directed the thoughts of philosophers to phenomena in which a theory of "action at a distance" gave the clue to many important developments. It is not, therefore, surprising that the thinkers of that day looked to similar theories to help them in gaining an insight into magnetic laws, and their efforts met with a certain amount of success, although the facts were more complicated than in the gravitation case, since not only attraction but repulsion had to be accounted for. Indeed, when we consider the apparatus at their disposal, this success is surprising and highly creditable.

It is true that the theory of action at a distance, besides being unthinkable, breaks down in the attempt to make it give even approximately quantitative data in many simple magnetic problems which have to be solved at the present day. Nevertheless, the work was so well done for the class of problems to which it is adapted that for these problems, including especially some connected with terrestrial magnetism, the same methods are still followed. We therefore propose to devote a short space to an explanation of these methods and the quantitative laws to which they led.

**Magnetic Influence at a Distance. The Torsion Balance.**—We can examine experimentally the force of attraction or repulsion between two magnetic poles only when the magnets employed are at some little distance from each other. Under these conditions it is observed that the following law is true, namely, *the force exerted by one magnetic pole on another in its neighbourhood is inversely proportional to the square of*



the distance between the poles. This is known as the law of inverse squares, and it may be experimentally proved by means of the torsion balance, usually known as Coulomb's torsion balance.

The torsion balance was originally invented by Michell, and is well adapted for measuring the very small forces which are called into play in these magnetic experiments. Fig. 18 shows the form of the instrument

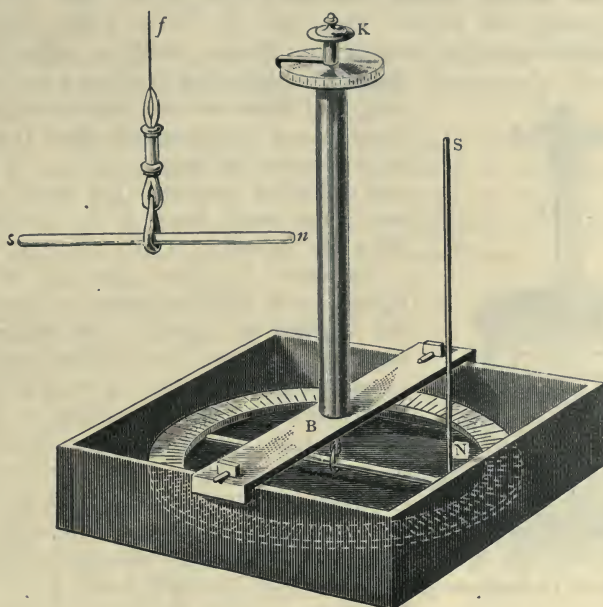

Fig. 18.—Coulomb's Torsion Balance.

as used by Coulomb, and Fig. 19 gives a modern form. In some respects the latter is not so well designed as the former.

The instrument consists essentially of a silver wire  $f$ , by which the magnet  $n s$  is suspended, and the torsion of which is measured. This wire is attached to a top  $k$  called the torsion head, which moves upon a graduated circle, on which the angle of torsion is read by means of the index. The knob  $k$  is employed to adjust this circle and the magnet  $n s$ . A second large graduated circle opposite  $n s$  serves to measure the angle through which the magnet  $n s$  moves. The second magnet  $N S$  is held with its lower pole  $N$  on a level with the magnet  $n s$ . When a wire is twisted, the force with which it tends to untwist is proportional to the amount of twist, hence the force required to twist  $x$  degrees is  $x$  times the force required to twist one degree. In other

words, the *force of torsion is proportional to the angle of torsion*. If  $\theta$  be the measure of the angle of torsion, and  $F$  the force, then  $F = \theta \alpha$ , where  $\alpha$  is a constant depending on the size and properties of the wire and the mode of measuring the angle.

In Coulomb's balance (Fig. 18) the open wooden box was 36 inches square by 19 inches deep, and the large graduated circle, 34 inches in diameter, was fixed 9 inches from the bottom of the box. The vertical tube surrounding the torsion wire was 30 inches high. The details of the suspension of the magnet are shown somewhat enlarged at the side. The deflecting needle  $n s$  was 24 inches long, and therefore the upper pole was so far away as not to appreciably affect the position of the suspended magnet  $n s$ . In Fig. 19 this deflecting magnet is too short, and some correction would have to be introduced to allow for the effect of the upper pole.

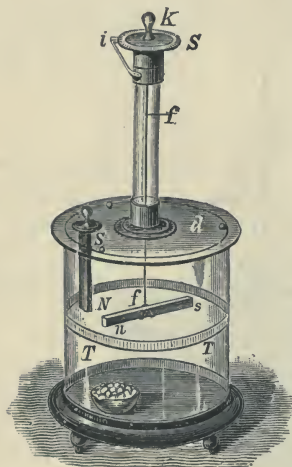

Fig. 19.—Magnetic Torsion Balance.

In order to prove the law of inverse squares with the instrument a non-magnetic rod of brass or copper is first suspended instead of  $n s$ , and the whole instrument is turned round until this rod rests in the magnetic meridian with no torsion on the wire. The reading on the torsion head is then read, and also the position of the suspended rod as shown on the large circle. The magnetised needle is then substituted for the suspended rod, and if the preceding adjustment has been carefully made it will take up the same position of rest. In this position no forces tending to turn  $n s$  round the axis of the suspending wire will be acting upon it. The deflecting magnet  $n s$  is now introduced with its north-seeking pole at a definite distance from the position of rest of the north-seeking pole of  $n s$ . This distance can either be actually measured or obtained by calculation by observing the angular position of  $N$ . The north-seeking pole of  $n s$  will be repelled, and it is to be brought back to its former position in the magnetic meridian by turning the torsion head so as to twist the wire. The number of degrees through which the torsion head has been turned must then be noted, and the experiment repeated with various positions of the magnet  $n s$ . From the experiments the law can be deduced.

Suppose, for instance, that when  $N$  and  $n$  are 6 inches apart the torsion head has to be turned through  $65^\circ$  in order to bring  $n s$  into the magnetic meridian. If now  $N$  be moved nearer so that it is only 2 inches from the zero position of  $n$  it will be found that a much

greater twist must be given to the torsion head. Let us suppose that it requires 1 complete turn and  $220^\circ$  additional to bring  $n$  to its position. The total torsion on the wire now will be  $360 + 220 = 580^\circ$ , or nearly 9 times the former torsion of  $65^\circ$ . But the distance is now only one-third of what it was before; hence the repulsive force between the two magnetic poles is inversely as the square of the distance. By examining the torsion required at other distances the law can be more fully proved.

By experiments of this kind, and also by varying the strength of the poles, Coulomb proved the following fundamental law of magnetism:—

*The force exerted between two magnetic poles is proportional to the strength of the poles, and inversely proportional to the square of the distance between them.*

Thus, if  $m$  and  $m_1$  be the strengths of the poles, and  $d$  the distance they are apart, then the force  $f$  exerted between them is

$$f = \frac{m m_1}{d^2}$$

If we make  $f$  and  $d$  unity, the product  $m m_1$  must also be unity, and it follows that *the unit magnetic pole is that which repels a similar and equal pole at unit distance with unit force.*

This unit is defined in the centimetre-gramme-second or C. G. S. system, which is the system of fundamental units employed in scientific work, as that *pole which repels a similar and equal pole at the distance of one centimetre with the force of one dyne*, the dyne being that force which, steadily acting for one second, causes a mass of a gramme to move with a velocity of a centimetre per second.

**The Magnetic Field.**—We have noticed that a magnet exerts a certain influence on pieces of iron and steel which lie in its neighbourhood. The pole of another magnet also experiences a force varying with its distance from the magnet. The region through which a magnet exerts this magnetic influence, or force, is termed its *magnetic field*. The force which a magnetic pole experiences at a point in the magnetic field is determined by the *intensity of the field* at that point, and its direction is that of *the line of force passing through the point*. The latter is the direction in which a free *north-seeking* pole would move. The *intensity of the field at any point is measured by the force exerted on a unit pole placed at that point*, and the *unit intensity is that which exerts the force of a dyne on a unit magnetic pole*. If  $f$  be the force which a pole of strength  $m$  experiences at a point where the intensity of field is  $H$ , then

$$f = m H.$$



By equating this value of  $f$  to the preceding we have

$$mH = \frac{\kappa m_1}{d^2}$$

or,

$$H = \frac{m_1}{d^2}$$

which means that the intensity of the field due to a magnetic pole at a point  $d$  centimetres away is equal to the strength ( $m_1$ ) of the pole divided by the square of the distance  $d$ .  $H$  is also the force acting on a unit pole at the point considered owing to the existence of the pole  $m_1$  placed  $d$  centimetres away, and the direction of  $H$  is in the line joining the point to the position of  $m_1$ .

**The Magnetic Moment of a Magnet.**—It is, however, impossible to have a single magnetic pole existing independently of one of opposite character; hence it becomes necessary to determine the action produced on these combined poles. The tendency of the force to turn an ordinary bar magnet suspended horizontally in a magnetic field may be determined by considering the action on one of its poles, and since the action on the other tends to turn the magnet in the same direction we combine the two by doubling the first if the forces be parallel. Thus in a *uniform* field two equal opposite and parallel forces act on the poles of a bar magnet, tending to turn it round its central point, and set it in the direction of the lines of force. The pair of forces acting thus are in mechanics termed a *couple*, or a *torque*. In a field of intensity  $H$ , the pole of a magnet of strength  $m$  is acted on by a force equal to the product  $Hm$ , and if the distance between the poles be  $l$ , then the torque on the magnet placed at right angles to the field is

$$T = m l H.$$

The product  $m l$  is termed the *magnetic moment* of the magnet. It is evident, from the above formula, that the magnetic moment of a magnet may be considered as defined by the couple acting on a magnet placed perpendicular to the direction of the forces in a field of unit intensity ( $H=1$ ).

**The Intensity of Magnetisation.**—We have already referred to the fact that some kinds of steel and iron can be more highly magnetised than others, or in other words that the maximum strength of a magnet of given size and weight depends on the quality of the material. Also, the actual strength depends upon the magnetising forces employed as well as upon the size and shape of the material. In comparing magnets with one another, it is therefore useful to bring them to a uniform standard. To do this, the actual magnetic moment is observed by well-known



methods, amongst which may be mentioned the *magnetometer* method of Gauss. Then the *magnetic moment* of each magnet is divided by its *volume*, and the quotient is called the *intensity of magnetisation*. The intensity of magnetisation is therefore the magnetic moment of a unit of volume of the magnet on the assumption that the magnetic moment of each unit of volume is the same. This assumption, in most cases, is not justified by experiment, and therefore the intensity of magnetisation calculated as above is only the *average* magnetic moment per cubic centimetre, and not necessarily the actual magnetic moment of any cubic centimetre taken at random.

### III.—MAGNETIC CURVES AND LINES OF FORCE.

Thus far, in developing the laws of magnetism, we have tacitly assumed that there is a definite point on the magnet from which the distance  $d$  (page 27) can be measured. The experiment of dipping the magnet in iron filings (Fig. 5), however, shows that the filings do not adhere to a single point, but are spread over a large portion of the polar surface at the end of the magnet. From what spot, then, must  $d$  be measured? In the old, or polar, theory of magnetism which we have been discussing, this difficulty was met by assuming that the force was due to the action of a magnetic fluid spread over the polar surface of the magnet with a density varying from point to point. The mass-centre, or centre of gravity, of this fluid was calculated by well-known mathematical methods, and from this mass-centre the distance  $d$  was measured. By further assuming that a positive (+), or repelling fluid was spread over the north-seeking pole and a negative (-), or attracting fluid over the south-seeking pole, the forces at various points in the magnetic field could be calculated with tolerable accuracy, provided those points were not too close to the magnet.

The great objection to this theory, apart from its artificiality, is that it entirely ignores the part played by the medium lying between the different magnetic poles. When one body acts upon another at some distance from it, it is only reasonable to suppose that there is some connecting link or links, although the nature or mode of action of those links may not be evident. For the transmission of a pulling force we can imagine something of the nature of a rope, and for a pushing force something of the nature of a rod or a strut. Energy may also be transmitted from place to place by means of wave motion, as in the case of radiant heat, light, etc.; but even here the action of the medium is absolutely necessary, as without it no wave motion could be transmitted. In all such cases there must be a *continuous medium* between the interacting bodies, for without it the transmission of the action from one to the other is absolutely unthinkable.

In the magnetic cases under consideration we are dealing with steady forces and not with radiations. The rope or rod method of transmission seems, therefore, the more appropriate. But in this method, when things settle down into equilibrium, the transmitting medium (rope or rod) is in a state of strain, either tensile, compressive, or otherwise. The medium is under stress produced by the strains which call into play the forces by which the stress is transmitted through the medium from point to point, until the force reaches and acts upon the distant body.

The paths by which the forces are thus transmitted through the medium are perfectly definite, and may be visualised by lines drawn through the medium from one body to the other. To Faraday belongs the great honour of first realising this way of looking at the facts in-

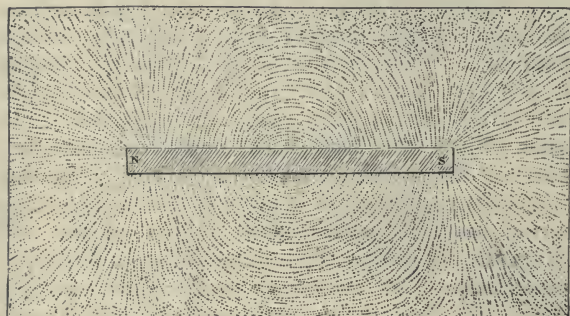

Fig. 20.—Magnetic Curves of a Bar Magnet.

involved in magnetic and electrical phenomena and of first pointing out the necessity for taking the medium into account. Not only so, but, in the case of magnetism, he devised means by which the shape of the lines of force may be shown at least approximately, and

to the lines as so shown he gave the name of "magnetic curves."

**Magnetic Curves.**—These are very readily produced in the following manner. Place over a bar magnet lying on a table a sheet of glass or stiff cardboard, and sprinkle iron filings on the top of this sheet. Either as they fall or with the assistance of a little gentle tapping on the sheet, the filings will arrange themselves in curves similar to those depicted in Fig. 20. The fact is that each little filing as it falls on the glass comes within the magnetic field of the bar magnet, just as much as the rod A, Fig. 11, is in the field of the magnet N S. Like the rod, then, the little filing becomes a magnet by induction, and in the commotion produced by the fall or the tapping, it is free to turn its length or longer axis in the direction of the magnetic force, and actually does so. In this way the curves are formed, and consist of strings of little induced magnets placed with unlike poles close together or in contact. Similar curves (Fig. 21) are obtained from a horseshoe magnet by placing the magnet underneath, and at right angles to, the cardboard with its poles pressed against the under surface. Notice how, in each case, the curves



seem to start out from various parts of the poles of the magnet, and if the course of any complete curve be traced, it will be found to commence on one polar surface and end on the other. In these two cases the action depicted is that of one pole of a magnet on the opposite pole of the same magnet, an action which we might have expected, especially between the poles of the horseshoe magnet, although the magnetic forces are too feeble to produce any visible effect on the rigid steel.

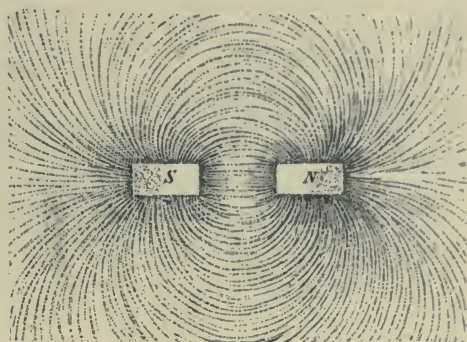

Fig. 21.—Magnetic Curves of a Horseshoe Magnet.

Similar curves, however, are produced between unlike magnetic poles, even when these belong to different magnets. Look at the central space in Fig. 22, which depicts the magnetic curves for two bar magnets placed in line with one another, and compare it with Figs. 20 and 21; Figs. 23 and 24 are also very instructive. In these we have two similar bar magnets placed parallel to one another, with the like poles adjacent in Fig. 23 and the unlike poles adjacent in Fig. 24. Notice how in Fig. 23 the lines setting out from adjacent like poles appear to turn aside from one another and to trend towards a more distant unlike pole. We seem to be looking at a picture of the actual repulsions which we know exist, whilst in Fig. 24 we have a picture of the actual attractions.

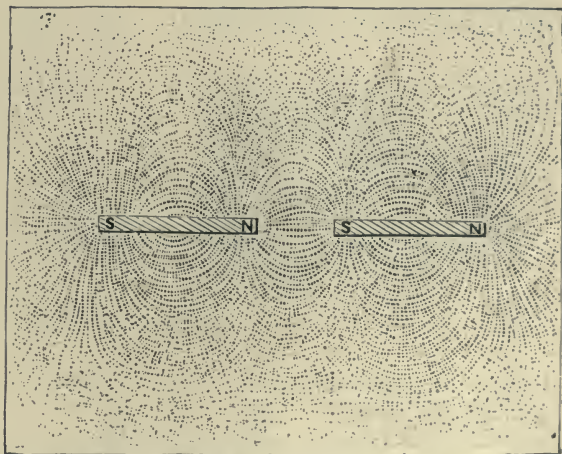

Fig. 22.—Magnetic Curves of Two Bar Magnets in Line.

It may be well to mention here that further

research shows that the action in the medium is of the nature of a tension or pull along the lines of force, and a pressure or push at right

angles to them, and bearing this in mind the above figures become very suggestive.

**Influence of Change of Medium.**—The question still remains as to what the actual medium is which is concerned in the transmission of these actions. It is not

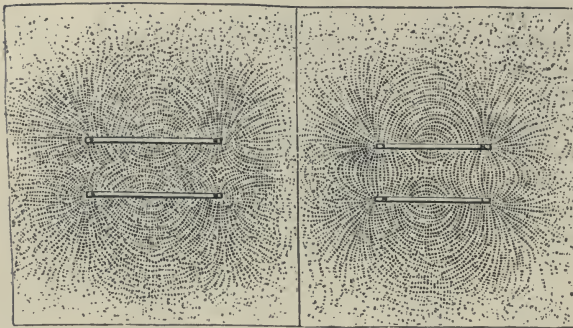

Fig. 25.

Fig. 24.

Magnetic Curves of Two Parallel Bar Magnets.

the atmosphere, for the action takes place as readily across a vacuum; moreover, if the air be replaced by glass, cardboard, or many other substances the change in the action, if any, is very minute. At first sight this would seem to tend towards showing that the older theory is right,

at least, so far as disregarding the effect of the medium is concerned. There are, however, certain materials which profoundly modify the action if they be substituted for the air or any of the other substances named above. These are the magnetic metals, iron, nickel, and cobalt, amongst which iron stands pre-eminent. Indeed, we shall see later that most materials

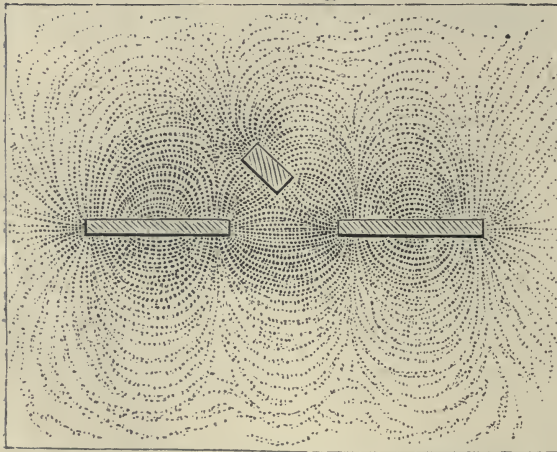

Fig. 25.—Effect of Soft Iron on Field between Two Unlike Poles.

produce some modification, though the change is almost infinitely less than in the case of iron. There are strong reasons for supposing



that the medium primarily answerable for the transmission is the luminiferous ether which transmits the waves that constitute light. In the case of light, however, the presence of gross matter modifies the transmission, and similarly with magnetic forces, gross matter produces some modification which is only of considerable magnitude when the matter consists largely of iron, nickel, or cobalt.

The examination, therefore, of the influence of gross matter on the transmission of magnetic forces is not only of practical but also of high theoretical interest, and as iron has the greatest influence, experiments in which it is used will be most striking. Let us, for instance, introduce a piece of unmagnetised soft iron in an unsymmetrical position in the field depicted by the magnetic curves of Fig. 22. The result is shown in Fig. 25. Still more striking are the effects shown in Fig. 26, which is copied from Faraday's researches. As we shall see later, in a uniform field the filings should lie in straight parallel lines. Such a field is shown depicted by filings in section *A* of the figure, the deviations from absolute parallelism and straightness being due to the disturbing influence of the filings themselves. If into this field a bar of unmagnetised soft iron be introduced, the filings arrange themselves as shown in section *B*, whilst if we use a ball or sphere instead of the bar, we obtain the result shown in section *C*.

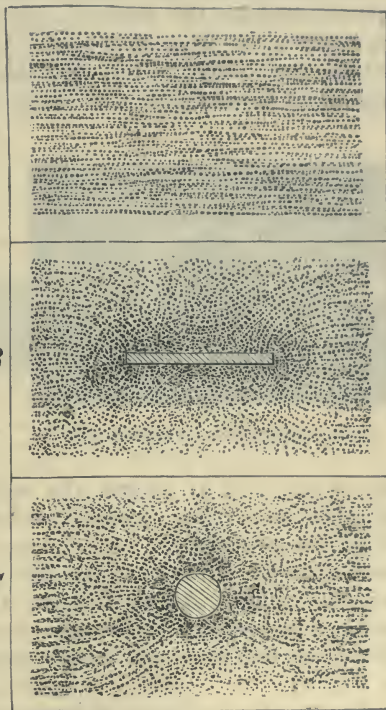

Fig. 26.—Effect of Soft Iron on a Uniform Field.

Another striking case of some practical importance is that depicted in Fig. 27, in which a flat iron ring is shown placed between two magnetic poles, A and B, of opposite polarity. Provided the iron of the ring be thick enough, it will be found that no magnetic curves can be traced in the central plane of the ring, shown in section in the figure. Assuming that A is a north-seeking pole, many of the lines issuing from it are deflected and drawn towards the iron, which they enter, but not to emerge on the inside of the ring. On the contrary, they continue

in the iron and pass round the ring to the points symmetrically opposite their points of entry, where they emerge to continue their course towards the south-seeking pole. The ring thus becomes magnetised by induction in such a manner that the left-hand outer face, as we shall explain presently, exhibits south-seeking polarity, and the right-hand outer face north-seeking polarity; no polarity can be detected on the inner surface of the ring.

From an examination of these figures we deduce that the iron profoundly modifies the magnetic curves, and that it appears to gather up, as it were, the lines into itself. In other words, the lines seem to go out of their way to run through the iron rather than through the air, as if they found the paths through the iron to be easier ones.

This effect was long ago ascribed by Lord Kelvin (then Professor William Thomson) to what he called the greater *permeability* of the iron. A still more recent way of expressing the same idea is to say that the *reluctance* of iron as regards the magnetic flux is less than that of air.

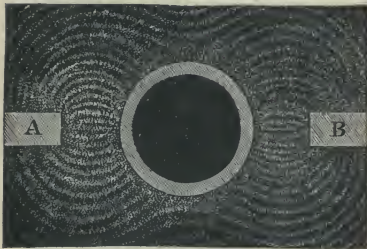

Fig. 27.—Lines of Force and Screened Space.

**Lines of Force.**—In the preceding experiments iron filings thrown hap-hazard on a card cannot be expected to give more than a general idea of the direction of the mag-

netic forces, and as regards the *magnitude* of the forces the indications must be even more approximate. Moreover, the plane on which the filings are arranged is not a plane in which all the forces act, for at some parts, at least, and especially close to the poles, the actual forces must be in lines passing obliquely through the glass or cardboard. Still further the presence of the filings must modify the forces in a manner similar to, but in a less degree than, the large piece of iron depicted in Fig. 25.

If instead of using filings we carry a small magnetic needle about in the magnetic field, and draw lines to which it is always a tangent, we obtain lines which converge on the poles as shown in Fig. 28. These lines being in the plane in which the forces act are actual lines of force, except so far as the field may be disturbed by the presence of the little search magnetic needle. Since every line, straight or curved, has two directions, it is now necessary to specify the direction in which these lines are supposed to run. Remembering that the direction of the magnetic force is that in which a north-seeking pole would tend to move, we see that the lines run *from* the north-seeking pole and *towards* the south-seeking pole. These directions are usually indicated by

barbed arrowheads placed on the lines, and it will be noted that each line either begins or ends (sometimes both) on the magnet. This is a peculiarity of magnetic lines of force produced by permanent magnets, though not necessarily of such lines produced by other means.

In Fig. 28 the external lines of force are continued through the body of the magnet, and where they are not broken externally they form closed loops, no two of which cross one another. Even those that are broken externally form similar closed loops, but considerations of space prevent us from drawing the whole of the loop in each case. Similarly, when soft iron is placed in a magnetic field, as in Figs. 25 and 27, the lines run through the iron and do not end at one part of the surface to start afresh at another part. This property of the mag-

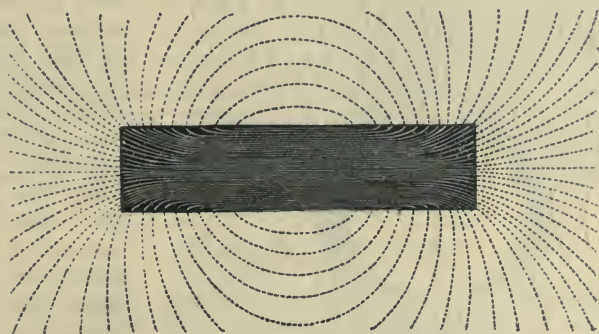

Fig. 28.—Lines of Force of a Bar Magnet.

netic lines should be carefully borne in mind, for they differ in this respect from the electric lines of force which we shall have to consider presently. The reasons for thus drawing the lines *through* the material will be explained later; we obviously cannot follow them there with our iron filings test or with our small magnetic needle.

**Intensity of Field shown by Lines of Force.**—In solving magnetic problems it is necessary that the lines of force should indicate not only the *direction* but also the *magnitude* of the magnetic forces, *i.e.* the intensity of the field (see page 27). We have now to explain how this is accomplished. Suppose the lines *evenly* drawn, not in one plane only, but as radiating in solid space from a *single point pole*. Now imagine a small non-magnetic ring moved near the pole so as to always have its plane at right angles to the lines. The number of lines that pass through the ring will vary inversely as the square of its distance from the pole. But this is the law of force. Hence this number may be taken to measure the force at any point. Since the lines of force may be drawn to pass through every part of the



magnetic field, the intensity of the field at a point may be measured by the number of lines of force which pass through a unit area placed perpendicular to the direction of the lines of force at that point. In passing from the single pole to the actual case we can follow the same rule, and so draw our lines that the *number passing* through the *unit area*, placed perpendicular to them, shall express the *actual force* at the centre of that area. It is important to note that we do not assert that more lines might not be drawn in the intervening spaces which would be as truly lines of force as those we retain. In fact, the whole space is under magnetic strain, and an infinite number of true lines of force

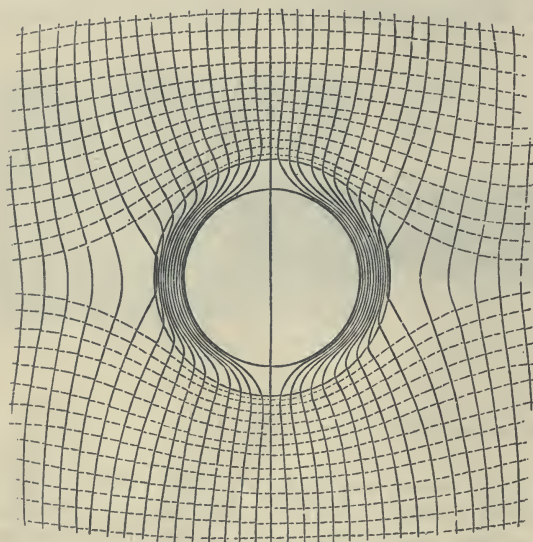

Fig. 29.—Lines of Force deflected into Iron Ring.

could be drawn. By adopting the above convention, however, and restricting the number, we obtain valuable assistance in our numerical work. Under this convention, wherever the magnetic force is weak the lines are few and sparsely scattered, whereas where the force is great the lines are numerous and are packed closely together. A *uniform magnetic field* will be one in which the intensity of the field at every point determined in this manner is the same; in other words, the field is uniform when the lines of force are parallel and equidistant. Thus a small field at a considerable distance from a magnet will be fairly uniform; hence the magnetic field due to the earth in a room free from the presence of magnets and magnetic material will be practically uniform, and the direction of the lines of force will be that of the dipping needle placed so as to move in the plane indicated by the declination needle.

In Fig. 29 the disturbance of the lines of force of such a uniform field by an iron ring placed in its centre is graphically depicted. Before the iron ring was inserted the field would be represented by a series of equidistant parallel lines passing vertically from the top to the bottom



of the figure. The deflection of these lines towards the iron in the space outside the ring and their exclusion from the space inside the ring which they forsake for the paths through the iron should be carefully noted. According to the general rule, wherever the lines are drawn wider apart in the outer space a weakening of the magnetic force is indicated; and where they are crowded together the force is greater than it was before the insertion of the ring. Theoretically, the central line passes across the ring because there is no reason why, on entering the iron, it should pass to either side. Practically, however, no field would be found inside the ring if the latter were sufficiently massive.

Another set of lines is shown in the figure passing across from left to right; to distinguish them from the lines of force they are dotted. On examination it will be found that these lines are everywhere at right angles to the lines of force which they cross. They are the magnetic *equi-potential* lines, and indicate the directions in which there is no component of magnetic force in the field. In other words, an isolated magnetic pole placed on one of these lines would experience no force tending to cause it to move along the line. They correspond to level surfaces in the theory of gravitation, and are sometimes useful in theoretical investigations.

#### IV.—TERRESTRIAL MAGNETISM.

A compass needle, such as is shown in Fig. 9, if placed in a magnetic field, will set itself along the lines of force, since in this position the turning moment, or torque, acting upon it becomes zero. Therefore, the fact that a compass needle placed almost anywhere on the surface of the earth takes up a definite position may be accepted as an indication that it is in a magnetic field, the position it takes up being the one in which it lies most nearly in the direction of the lines of force of that field. The field so pointed out is that due to the earth, which, as Gilbert asserted, behaves as a large magnet. The direction taken up by the compass needle is approximately, but not accurately, north and south; the direction actually indicated is, as we have previously remarked, known as that of the *magnetic meridian* at the place, and the angle between this and the true geographical meridian is known as the *declination* or *variation* of the needle. The declination has widely different values at different points on the earth's surface, and the fact that the two meridians are not identical shows that the magnetic and geographical poles do not coincide.

Besides the form of needle termed the declination needle, there is another termed the inclination, or dipping needle, which we have described on page 16. The angle made by the direction of the

needle and the horizontal plane is called the *inclination*, or *angle of dip*. It has been ascertained that the inclination or dip also varies from place to place. The maximum inclination occurs at the magnetic poles, where the needle is vertical, and at about half-way between these poles the angle of inclination is zero, the needle lying horizontally.

In the northern hemisphere generally the inclination needle has its north-seeking pole dipping downwards, and in the southern hemisphere its south-seeking pole dipping downwards. It has been already pointed out that the magnetic north pole of the earth must have opposite magnetism to that of the north-seeking end of the magnetic needle.

A complete knowledge of the earth's magnetic field at any place is usually obtained by three distinct measurements by which what are known as the *magnetic elements* of the place are determined. These magnetic elements are—

The *declination* or *variation*,

The *inclination* or dip,

The horizontal component of the magnetic force, usually called the *horizontal force*.

Such measurements have been made at various points on the earth's surface and the results embodied in charts which (*see* pages 41 to 51) show at a glance the value of the particular element charted at all accessible points. The chart for the variation is an extremely important one for mariners, as without making due allowance for the variation navigation on long ocean voyages could not be carried on. Fairly good measurements of the magnetic elements may be made with comparatively simple apparatus, but for their determination with high accuracy more elaborate arrangements are necessary.

**Measurement of Declination.**—For the accurate determination of the declination at any place an instrument similar to that shown in Fig. 30 is required. The particular pattern illustrated is that known as the Kew Magnetometer, as made by Elliott Bros., and is similar to the one used by Prof. Rücker in his important researches on terrestrial magnetism. In the position shown it is arranged for the determination of the magnetic meridian, and also for the vibration experiments which we shall describe later.

The instrument consists of a small circular table *E*, with a graduated rim, the table being mounted on levelling screws and capable of adjustment so as to be accurately horizontal. The central part of this table, carrying the observing apparatus, can be moved relatively to the rim round the common vertical axis, and its exact position read off on the divided circle by the microscopes *mm* and verniers provided. A torsion head *A* carries, by means of a long, torsionless fibre protected by a glass

tube, the magnet *M*, which consists of a hollow *tube* of steel, carefully magnetised. One end of this tube is closed by a glass plate on which a divided scale is engraved, and the other end is closed by a double convex lens whose focal length is exactly that of the tube, so that the engraved scale lies in the principal focus of the lens. *C* is a mirror

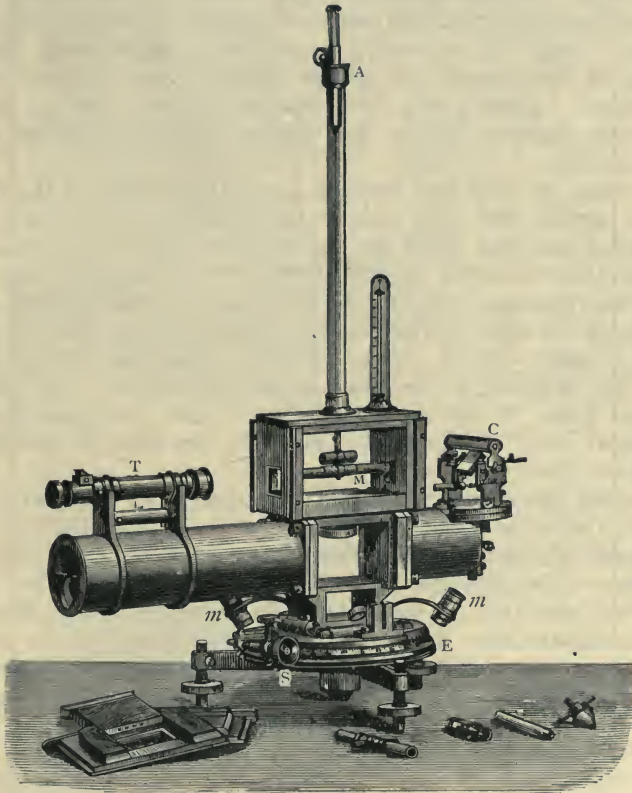

Fig. 30.—Kew Magnetometer, arranged for Declination and Vibration Experiment.

which illuminates the scale so that it can be easily viewed in the field of the observing telescope *T*, which rests in *V*s clamped on the large tube and carries a level *L* for purposes of adjustment. The magnet *m* slides in the lower of two brass cylinders which hang from the end of the fibre, and its height is adjusted, by means of the screw at *A*, so as to bring the geometrical axis of the magnet to the same level as that of the telescope.



A preliminary observation suffices to set the instrument so that *M* hangs in the line between *c* and *t* with no torsion on the suspending fibre. With the magnet *M* accurately horizontal the final adjustment round the vertical axis is made by the tangent screw *s*, until the axis of the telescope and magnet are exactly in line. The position on the circle *E* is then read off. The magnet is now rolled over in the brass tube so that the scale is exactly reversed and another adjustment made, if necessary, with the tangent screw, the circle being again read when the axis of telescope and magnet coincide. This second reading with the magnet turned over is necessary because the magnetic axis of the magnet may not coincide with its geometrical axis.

The mean of these two readings gives the position of the magnetic meridian, and it now only remains to determine the position of the geographical meridian. This can be found by noting on a chronometer the exact time of transit of the centre of the sun over the central line of the telescope, the sun's image being reflected into the telescope by the mirror *c*, which turns round a horizontal axis. For this observation the magnet *M* is of course removed. The time of transit being known, the direction of the sun can be calculated by well-known astronomical rules. If the bearing from the place of observation of a fixed distant mark is known this mark can be used to determine the geographical meridian.

By taking the difference between the positions of the two meridians we obtain the value of the declination.

**Changes of Declination.**—Observations made with this and similar instruments show that the declination not only changes for *different places*, but also that it varies at *different times* at the same place. Places having the same declination at the same time may be connected together by certain definite lines, termed *isogonals*, or *isogonic lines*. The isogonic lines on which the declination is zero are called *agonics*. The isogonals for the year 1907 are represented in Fig. 31, which is reproduced from an official chart issued by the Hydrographic Department of the Admiralty. It may be again explained here that such charts are nautically known as *Variation Charts*, since the sailor has to use the term "declination" for one of the sun's co-ordinates, and it is unwise, where lives depend upon accuracy, to use the same word for two very different quantities, especially when, as in this case, they are both measured in the same units.

From the declination chart we see that one portion of the world has western declination, as shown by the continuous lines, the other part eastern declination, as shown by the dotted lines. The two parts are separated from each other by the agonics, or neutral lines, of which



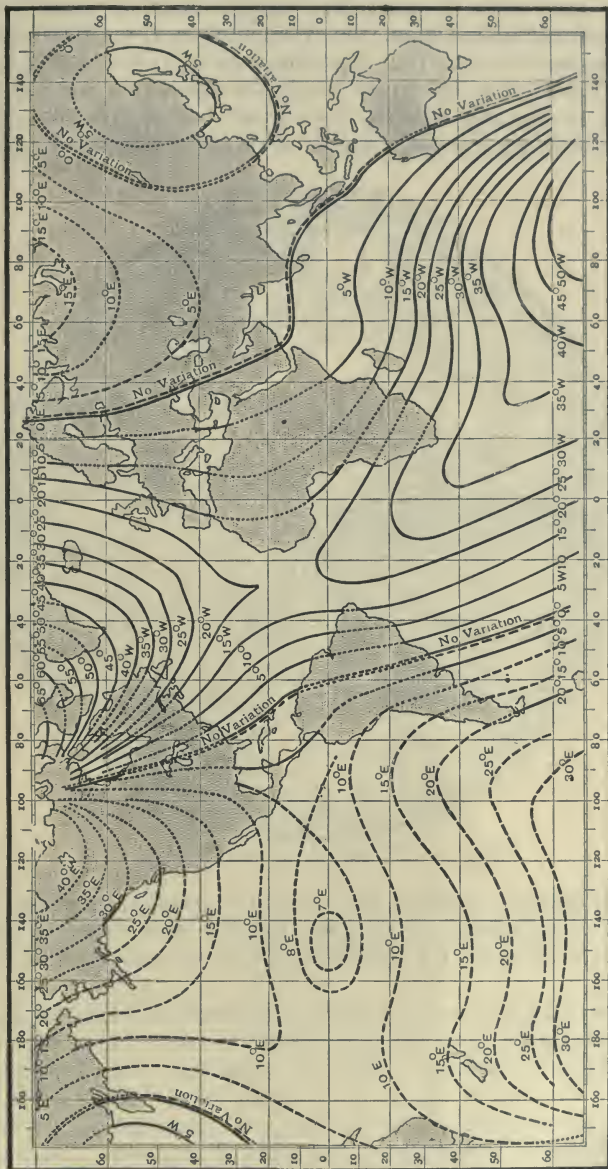

Fig. 31.—Declination or Variation Chart for the Year 1907.



of these poles are not fixed, but change slowly from year to year with the secular changes in the magnetic elements.

The lines on the chart give only the average values close to the points they pass over. The true isogonals are not nearly so smooth, for the value of the declination is affected by all kinds of local circumstances, so that the lines when drawn on a large scale do not run smoothly across the chart, but exhibit all kinds of irregularities. These are well brought

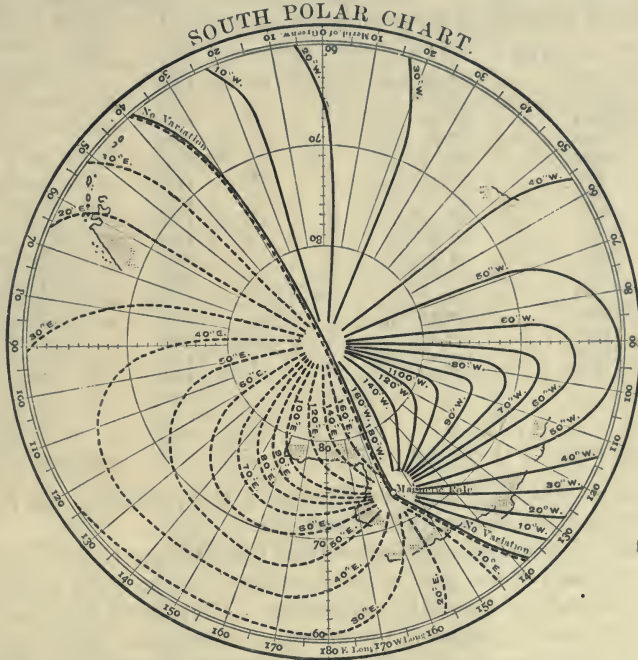

Fig. 33.—Declination Lines at South Pole (1907).

out in a laborious research undertaken by Professors Rücker and Thorpe. Fig. 34 gives the results of their magnetic exploration of the British Isles, and shows the true isogonals with all kinds of curious turns and twists in them. Combining these with a study of the geology of the various districts, the interesting deduction is made that the irregularities are due to "the presence of crystalline rocks, and especially of basalt, either visible on the surface or concealed by superimposed masses of sedimentary strata."

The changes which depend on effluxion of time are of four kinds, three being periodic and one irregular. The changes of declination which extend over long periods of time are termed *secular* changes. Besides



these, there are also *annual* and *daily* changes, the whole range being completed in the year or day respectively. In addition to the changes which resemble oscillations and recur regularly, there are changes of the nature of disturbances. These *irregular* changes, as a rule, appear at the same time as the aurora borealis, and will be again referred to when we consider atmospheric electricity.

Tables of secular changes show us that until the seventeenth century the declination for Europe was eastern, and then changed into western. The following tables give the declination observed at Paris and London :—

PARIS.			LONDON.		
In the year	1580	... 11° 30' east.	In the year	1580	... 11° east.
"	1618	... 8° 00' "	"	1622	... 6° "
"	1663	... 0° 00' "	"	1657	... 0 "
"	1700	... 8° 10' west.	"	1665	... 1° 22' west.
"	1805	... 22° 5' "	"	1692	... 6° 0' "
"	1818	... 22° 22' "	"	1700	... 9° 0' "
"	1828	... 22° 6' "	"	1748	... 17° 40' "
"	1849	... 20° 34' "	"	1800	... 24° 7' "
"	*1883	... 16° 20' "	"	1818	... 24° 41' "
"	*1891	... 15° 33' "	"	1830	... 24° 2' "
"	*1897	... 14° 59' "	"	1850	... 22° 30' "
"	†1897	... 15° 6' "	"	1867	... 20° 50' "
"	†1900	... 14° 51' "	"	1880	... 18° 35' "
"	†1903	... 14° 40' "	"	1891	... 17° 23' "
"	†1906	... 14° 28' "	"	1894	... 17° 4'.6 "
"	†1909	... 14° 12' "	"	1897	... 16° 50'.4 "
			"	1900	... 16° 29'.0 "
			"	1903	... 16° 19'.1 "
			"	1906	... 16° 3'.6 "
			"	1908	... 15° 53'.5 "

\* Parc St. Maur.

† Panthéon.

At present the declination for Europe is west, being on the decrease, after attaining a maximum value about 1820.

Gauss and Weber collected observations made during twenty-four hours, for four fixed days of the year, at different places on the globe, to determine the daily variations in the earth's magnetism. They found that the declination in Europe is a minimum in the morning, a maximum shortly after midday, and then decreases until evening. The maximum difference, although not the same for all seasons, is only about nine minutes of arc.

At the Observatory at Greenwich the declination needle is made to record its own movements throughout the day and night. The magnet carries a small mirror on which a beam of light falls in a dark room. The light is reflected on to photographic paper ruled for hours and minutes, and placed round a cylinder turned by a clock. The dark line traced by the spot of light is a permanent record of the movements of the magnet.

**Measurement of Inclination.**—To measure the inclination we have to arrange to swing a perfectly balanced magnetic needle in the vertical plane containing the magnetic meridian. For accurate results various



precautions are necessary to eliminate the instrumental errors to which even the best instruments are liable.

The instrument used is known as a "dip circle." With the comparatively simple instrument shown in Fig. 35 fairly accurate results can be obtained, but for the highest accuracy an instrument should be used similar to that illustrated in Fig. 36, which shows the usual Kew pattern as constructed by Elliott Bros.

In both instruments the dipping needle  $n$   $s$ , when in use, swings upon agate knife edges, from which it can be lifted without opening the case by means of movable Vs, which, when lowered, leave it on the knife edges in a perfectly definite position. In Fig. 35 the bluntly pointed ends of the needle move over the vertically mounted divided circle, on which the position of the needle can be read off. A more elaborate arrangement is used in Fig. 36,

where the position of the needle is read by bringing the ends into the centres of the fields of view of two microscopes  $M_1$  and  $M_2$ , carried on a diametrical arm which can be rotated round an axis coinciding with the axis of the needle, and whose exact position is to be read off by means of the two verniers at its ends on the large divided vertical circle. A slow motion can be given to these microscopes by the tangent screw  $s$ . The box containing the needle, in both instruments, carries a level  $L$ ,

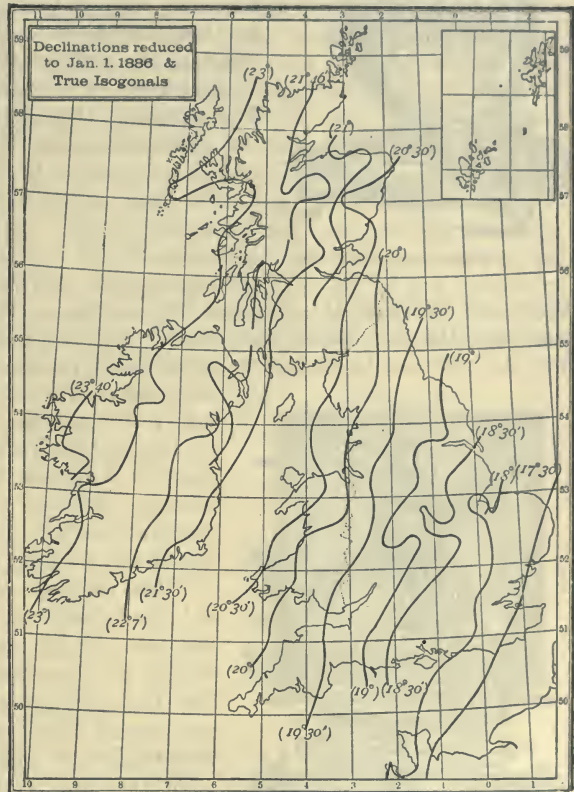

Fig. 34.—True Isogonals for 1886.

and is mounted to rotate about a vertical axis. Its position, and with it the exact position of the horizontal axis of the dipping needle, can be read off on the horizontal circle *c*. In Fig. 36 the horizontal circle can be read to 1' of arc and the vertical circle to 30".

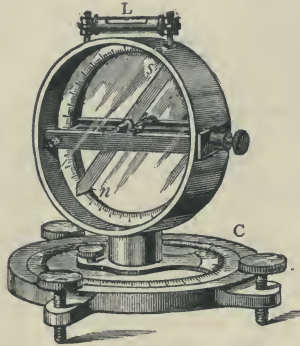

Fig. 35.—Simple Form of Dip Circle.

After adjusting the instrument so that the main axis is vertical the box is turned so that the needle lies east and west. In Fig. 35 the ends of the needle are brought as accurately as possible to the 90° marks. The needle is then vertical and swinging in the plane which lies magnetic east and west and at right angles to the magnetic meridian. In this plane no horizontal force can act on the needle, which comes to rest under the influence of the vertical components only of the earth's force and therefore stands vertical.

With the needle in this position the vernier on the horizontal circle is read, and the box being then turned 90° round the needle will come into the plane of the magnetic meridian as required. To eliminate instrumental errors both ends of the needle

are read, and the needle reversed face for face and the readings repeated; finally the box is turned round 180° and all the readings repeated; so that in all eight observations are made, and the mean taken as the most correct result.

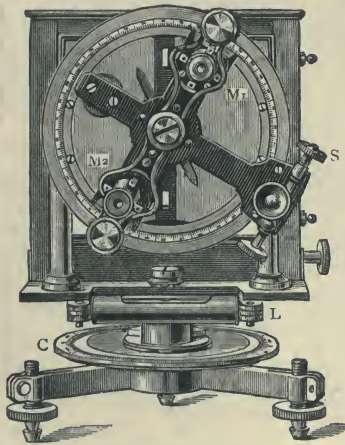

Fig. 36.—Kew Pattern of Dip Circle.

The verniers in Fig. 36 are set to 90°, and the box slowly rotated until the end of the needle appears in the centre of the field of the microscope. The box is then turned through 90°, and the needle being now in the magnetic meridian, the microscopes are moved until the end of the needle appears in the centre of the field of one of them. The verniers on the vertical circle are then read, and give one determination of the dip. By reading the other end,

and also reversing the needle and the box, as in the other observations, seven more determinations are obtained. There is, however, one source of instrumental error uneliminated, namely, the possibility of the centre of gravity of the needle not lying in the axis of rotation. To eliminate this the needle is lifted out of the box, and its magnetism reversed by

the method of double touch (page 21). It is then placed back on the knife edges, when the end which formerly pointed downwards now points upwards. With the newly magnetised needle the previous eight observations are repeated, and the mean of the sixteen observations should give a very accurate determination of the value of the angle of dip.

**Changes of Inclination.**—Like declination, inclination varies with place and time; here, too, places may be found that have the same inclination. The lines which join these places are called *isoclinic* lines, and the isoclinic line on which the inclination is 0 is called the magnetic equator, or *acclinic line*; from the magnetic equator to the magnetic poles the inclination varies from 0° to 90°. At the magnetic equator the inclination needle takes up a horizontal position; in the northern hemisphere its north pole points downwards, in the southern hemisphere its south pole points downwards, and at the magnetic poles it assumes a vertical position. The magnetic equator does not run parallel to the geographical equator, but cuts it at irregular intervals, as shown in the chart (Fig. 37), which is taken from the chart issued by the Admiralty for the year 1907. The numbers outside the chart on the right-hand side are the *tangents* of the angles of dip. The following figures show the secular changes of the inclination as observed at Paris and London:—

PARIS.		LONDON.	
In the year 1661	... 75° 00'	In the year 1576	... 71° 50'
" 1758	... 72° 15'	" 1676	... 73° 30'
" 1805	... 69° 12'	" 1720	... 74° 42'
" 1820	... 68° 20'	" 1830	... 69° 30'
" 1835	... 67° 24'	" 1867	... 68° 4'
" 1851	... 66° 35'	" 1870	... 68°
" *1883	... 65° 19'	" 1880	... 67° 36'
" *1891	... 65° 10'	" 1891	... 67° 23'.2
" †1897	... 65° 2'	" 1894	... 67° 18'.4
" †1900	... 64° 57'	" 1897	... 67° 7'.1
" †1903	... 64° 47'	" 1900	... 67° 8'.27
" †1906	... 64° 38'	" 1903	... 67° 0'.51
" †1907	... 64° 36'	" 1905	... 66° 55'.55
" †1908	... 64° 33'	" 1906	... 66° 55'.17
" †1909	... 64° 34'	" 1907	... 66° 56'.07
* Parc St. Maur.	† Panthéon.	" 1908	... 66° 56'.28

The mean inclination for 1906 at Kew was 66° 55'.17. It is difficult to determine whether the changes of dip are periodical; from 1835 to 1851 the dip for Paris seemed to be increasing, whilst for London it shows a steady decrease, but appears to have passed a definite minimum in 1906. A minimum also appears to have been reached at Paris in 1908.

**Measurement of Horizontal Intensity.**—The Kew Magnetometer already described (Fig. 30) can be used also to determine the value of the horizontal intensity usually denoted by *H*. Two sets of experiments are necessary. In one set the exact time of oscillation of the magnet *M* as mounted in Fig. 30 is determined, and from this we can deduce the value of the product of the magnetic moment *M* of the



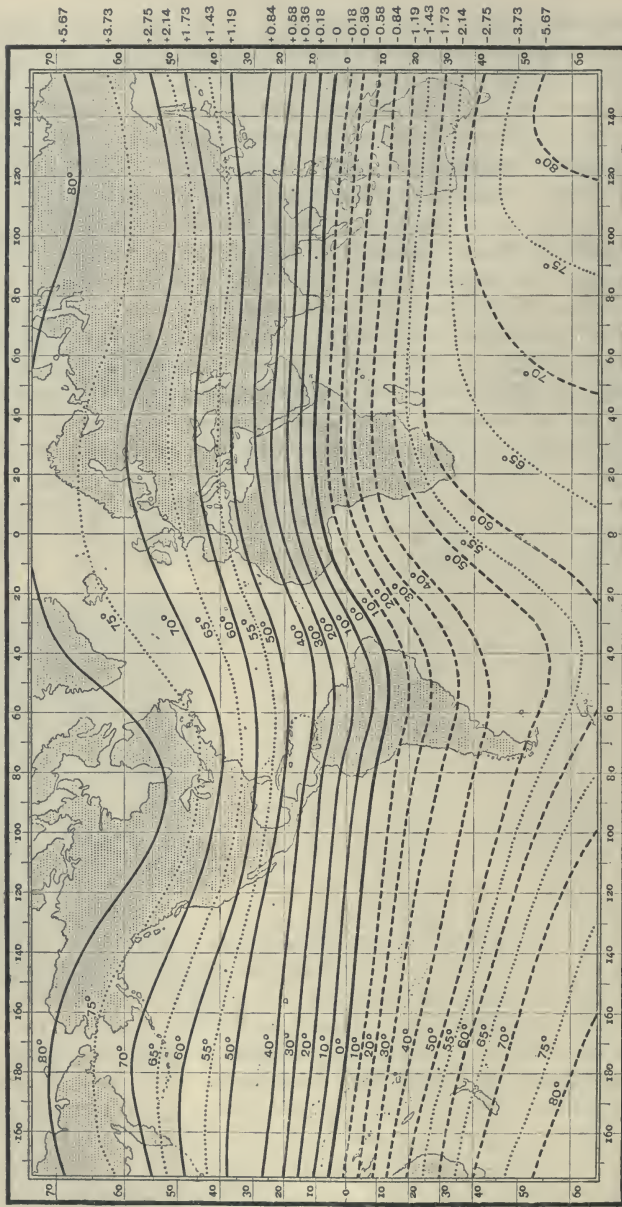

Fig. 37.—Isochinets or Lines of Equal Magnetic Dip for the Year 1907.

magnet and  $H$ . If  $n$  be the number of oscillations per second of the magnet when disturbed, and  $K$  its moment of inertia, we have

$$MH = 4\pi^2 n^2 K \quad (1)$$

To find  $n$ , the magnet is slightly deflected from its position of rest and then left to oscillate. The oscillations are watched in the telescope, and by noting the passages of the centre line of the magnet scale across the vertical thread of the telescope the time taken to make 100 or more vibrations is found and the value of  $n$  can be calculated.

To find  $K$  a non-magnetic rod of known moment of inertia  $K_1$  is inserted in the upper brass cylinder of the magnet holder, and the new value ( $n_1$ ) of  $n$  due to the new value ( $K+K_1$ ) of  $K$  is found; we then have

$$MH = 4\pi^2 n_1^2 (K+K_1) \quad (2)$$

and from (1) and (2)  $K$  can either be eliminated or calculated. Thus finally we find the value of  $MH$ .

To separate  $M$  and  $H$  another equation is required. This is obtained by arranging the instrument as in Fig. 38. The upper box and the transit telescope are dismantled, and the magnet  $M$  removed from the suspending fibre, its place being taken by another magnet  $M_1$ , which carries a little mirror  $m$  fixed below it and at right angles to its axis. Long carrier bars  $ss'$  are attached and the glass tube is fixed on the lower box so that the new magnet  $M_1$  is suspended from the fibre within it. Another telescope  $T_1$ , with a scale  $s$  attached to it, is fixed in the lower tube, and when the suspended magnet is at rest the zero of the scale should be seen on the cross wires of the telescope.

The magnet  $M$  used in the vibration experiments is now placed on the carriage  $c$  so that its centre is a known distance  $r$  from the centre of the suspended magnet. The latter is deflected and the whole instrument is turned round until the zero of the scale again coincides with the cross wires. The angle  $\alpha$  turned through is noted. By reversing  $M$  on the carriage and also by placing the carriage at the same distance  $r$  on the other side of the box, four values in all of  $\alpha$  are obtained and the mean is assumed to be the correct value.

Having found  $\alpha$  we have the equation

$$\frac{M}{H} = \frac{(r^2 - l^2)^2}{2r} \sin \alpha \quad (3)$$

where  $2l$  is the "polar" length of the deflecting magnet  $M$ . In exact work corrections are required for the temperature of the magnet  $M$ , and of the bar  $ss'$ , and for the effect of the earth's induction on  $M$ .

From equations (1) and (3) the separate values of  $M$  and  $H$  can be easily found by multiplication and division respectively.

The force thus measured is the horizontal component of the intensity of the field due to the earth. The total intensity of the earth's field

acting on either pole of the needle has the effect of two forces, one, the horizontal part (or component), pulling the needle into the magnetic meridian, and the other, the vertical component, pulling one end of the

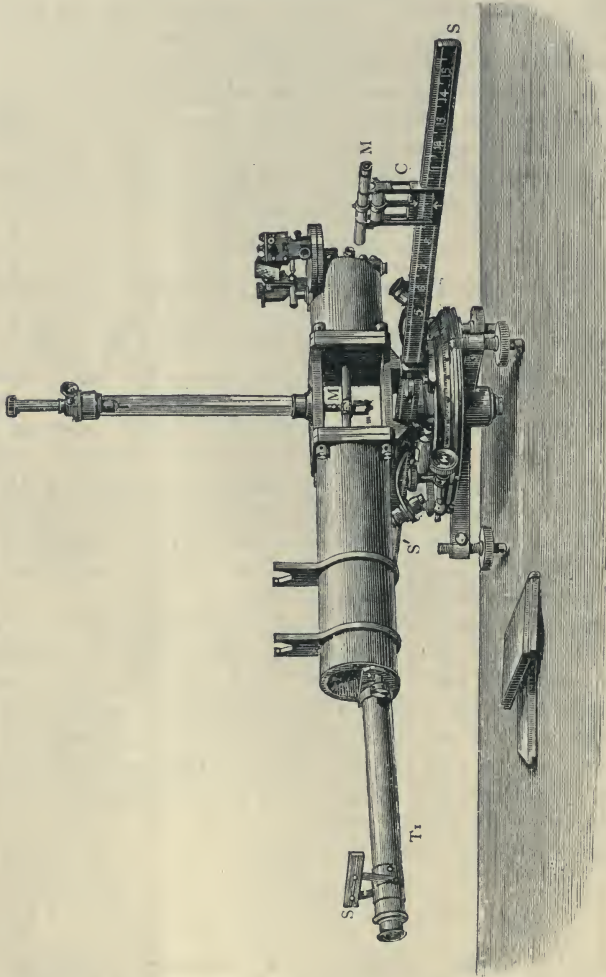

Fig. 38.—Kew Magnetometer Arranged for Deflection Experiments.

needle down. We may easily determine the total intensity when we know the horizontal component and the angle of dip. We have but to choose a scale and to construct a triangle thus: Draw  $AB$ , a horizontal line, to represent on the chosen scale the horizontal force; next draw  $BC$ , making the angle  $ABC$  equal to the angle of dip; then draw  $AC$



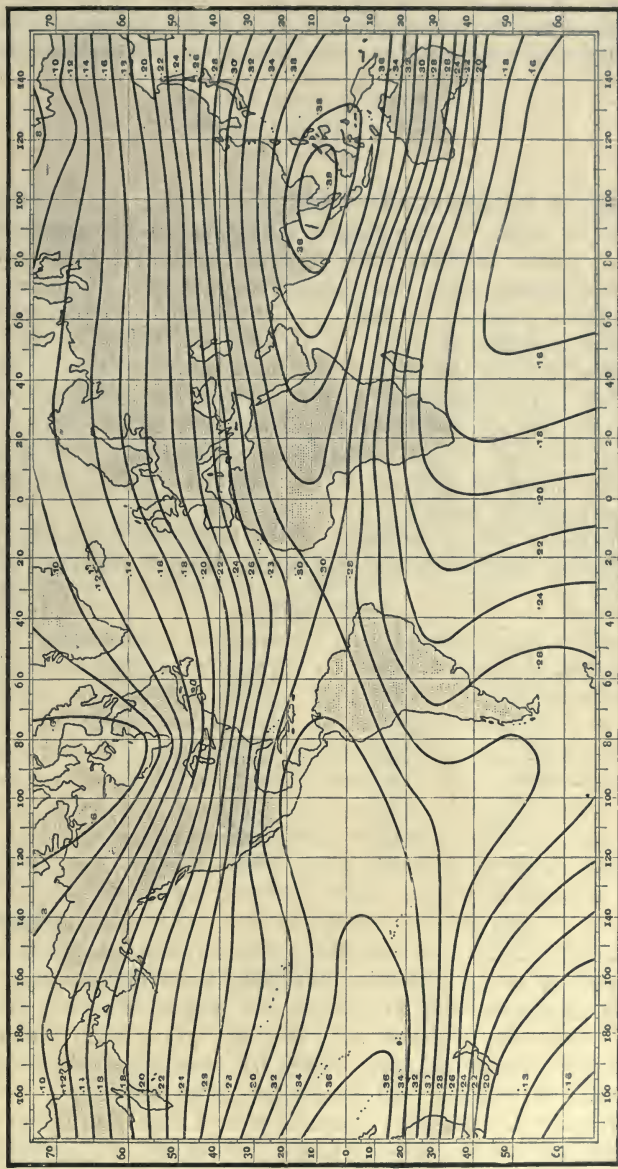

Fig. 39.—Isodynamics or Lines of Equal Horizontal Force for the Year 1907.

perpendicular to  $AB$ , and meeting  $BC$  in  $C$ . Then, on the chosen scale,  $AC$  represents the vertical component  $V$ ,  $AB$  the horizontal component  $H$ , and  $BC$  the total force  $T$ . From this triangle we deduce the equations

$$\begin{aligned} T &= H \div \cos A B C, \\ V &= H \times \tan A B C, \text{ and} \\ T^2 &= H^2 + V^2. \end{aligned}$$

**Changes of Intensity.**—As might be expected, the intensity varies from point to point of the earth's surface as do the declination and inclination. Charts showing lines of equal intensity, called *isodynamic lines* or *isodynamics*, have been prepared, and one of these for the horizontal force is shown in Fig. 39. In this chart the horizontal force at Greenwich is taken as unity ( $= 1$ ), and the figures on the various lines therefore express the ratio of the force on these lines to the force at Greenwich. The horizontal force is zero at the poles, where all the force is vertical, and increases towards the magnetic equator, but the curves exhibit curious and as yet unexplained sinuosities. The total force, on the other hand, is greatest at the magnetic poles, and diminishes towards the magnetic equator.

There is also a secular variation of the horizontal intensity, as shown by the following figures relating to London, Munich and Paris:—

London.			Munich (Germany).			* Paris (France).		
1860	...	'1755	1853	...	'19578	1891	...	'1953
1866	...	'1770	1857	...	'19706	1895	...	'1964
1868	...	'1775	1862	...	'19821	1900	...	'1970
1870	...	'1779	1867	...	'19973	1903	...	'1981
1872	...	'1785	1871	...	'20093	1906	...	'1990
1874	...	'1790	1873	...	'20155	1907	...	'1992
1884	...	'1819	1886	...	'20363	1908	...	'1995
1891	...	'18253	1899	...	'20587	1909	...	'1985
1894	...	'18287	1900	...	'20610			
1897	...	'18366	1903	...	'20656			
1900	...	'18450	1905	...	'20651			
1903	...	'18504	1906	...	'20655			
1905	...	'18523						
1906	...	'18524						
1907	...	'18533						
1908	...	'18528						

\* Panthéon.

The intensity which had been increasing since 1860 appears to have reached its maximum value in 1907, a fact which, of course, is not unconnected with the minimum of the "dip" in 1906. Intensity also has annual and diurnal changes; during the twenty-four hours it increases from morning till evening and decreases during the night.

Here we leave the subject of magnetism for a time, but we have still to deal with the magnetic properties of bodies and theories of magnetism, which will be much more satisfactorily discussed after the laws of electro-magnetism.

## CHAPTER II.

*ELECTROSTATICS.*

## I.—ELEMENTARY FUNDAMENTAL PHENOMENA.

IN the historical introduction we have referred briefly to the circumstances, as far as they are known, under which electrical, as distinct from magnetic, phenomena were observed from the earliest times, and incidentally we have had to describe briefly the phenomena referred to. Up to nearly the end of the eighteenth century these phenomena, almost without exception, belonged to the domain of electrostatics, or that part of the science which deals with the entity called electricity in a position of rest upon the surfaces of bodies. In modern times electrostatics has been quite overshadowed by the rapid growth of the knowledge of the properties of the electric current and the phenomena connected therewith. But as many of the ideas associated with the development of the earlier science permeate at least the literature and nomenclature of the later science, a careful study, from a modern standpoint, of the phenomena involved will be both interesting and instructive. Moreover, the existence of electrostatic actions and phenomena has to be borne in mind in many modern applications of electricity; and above all, these phenomena in their future development may lead us to a much more intimate knowledge of what the mysterious entity "electricity" really is.

In what follows some repetition of the elementary facts already described in the historical introduction is inevitable in a clear treatment of the subject, but such repetitions will be as few as possible.

**Electrical Attraction and Repulsion.**—If we rub a large glass rod with a silk pad, we observe that it will first attract light bodies and then after contact repel them. During the process we may notice a peculiar noise, and if the experiment be carried out in the dark we may further notice sparks passing between the rod and the rubber, and also that the rod becomes luminous. If we suspend a pith-ball by means of a silk thread, on bringing the rubbed rod near the pith-ball it will move towards the rod, touch it, and then be repelled. If the glass rod be again brought near the pith-ball, it will move away from the glass rod, and continue to be repelled until it has been touched by some other body. From this and similar experiments we conclude that in the



manner described certain bodies may be made to assume properties they did not before possess. The bodies when in this peculiar state are said to be electrified or "charged with electricity."

In order to ascertain whether electricity is communicated by electrified bodies to non-electrified bodies when brought into contact, let us suspend two pith-balls (Fig. 40) from the same point of support by dry silk threads, and touch the pith-balls *a*, *a* with the rubbed glass rod. The balls fly from the rod and also from one another. On bringing near them a third pith-ball *b* or any other light body, we find that though they repel one another they attract and are attracted by the light body, showing that they have become electrified by contact with the rubbed glass rod. From this we conclude that an un-

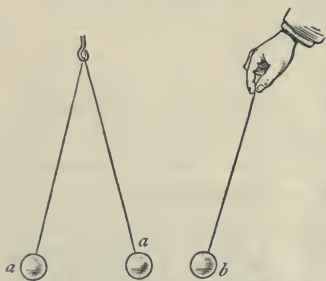

Fig. 40.—Electrical Attraction and Repulsion.

electrified body may be electrified by contact with an electrified body, and also that there is repulsion between two such bodies after contact. There is mutual repulsion between two electrified bodies, but there is attraction between a single electrified body and one that is unelectrified. Since electricity may be imparted from one body to another in the manner here described, we may speak of a body as being charged with electricity, or as having a certain charge, *though the only evidence we have of a body being charged* is the force it exerts on other bodies, whether that force be one of repulsion or of attraction. This property or behaviour of electrified bodies enables us to examine their electrical condition.



Fig. 41.—Gold-leaf Electroscope.

**Electroscopes.**—The two pith-balls already referred to give a ready means of ascertaining the electrical state of any body supposed to be charged, but they are not very sensitive. If instead we hang up two very light gold leaves, the sensitiveness will be increased. This is done in the gold-leaf electroscope, which, in its most elementary form, consists of two gold leaves hung side by side within a glass vessel from a metal wire attached to a metal plate or ball on the exterior of the vessel, as shown in Fig. 41. If we touch the metal knob of the instrument with a rubbed glass rod, the electricity of the glass rod reaches the gold leaves, causing them to diverge, as shown in the figure. We may further observe that the more strongly the rod is electrified the greater is the divergence of the leaves.

But the gold-leaf electroscope is not a very sensitive instrument, and it would be almost impossible to detect the presence of very small quantities of electricity with it, hence more sensitive instruments must be employed. Such an electroscope, invented by Behrens and modified by Riess, is shown in Fig. 42, the principal new feature being a Zamboni pile  $\kappa z$ . The electroscope consists of a single gold leaf hanging between two symmetrically placed discs  $k z$ , which are maintained at different electrical conditions, or (as we shall subsequently learn to describe it) at different potentials, one positive and the other negative, produced by the dry pile, or battery  $\kappa z$ . Lord Kelvin calls electroscopes of this class heterostatic, because they take advantage of an independent electrification to test the given electrification.

None of these instruments accurately measure electricity; they only indicate the electrical conditions of bodies. Apparatus which enable us to make exact measurements of the charges of electricity on bodies are termed *electrometers*, not *electroscopes*, and will be described farther on. The latter simply indicate the presence of electricity; the former do more: they indirectly measure the quantity.

#### Two kinds of Electrification.—

If we rub a glass rod with a piece of leather, and touch the knob of the gold-leaf electroscope, the leaves diverge; on rubbing the glass rod still more, and touching the knob of the electroscope, the divergence of the leaves will be increased; but if, instead of again using the glass, we touch the knob with a rubbed rod of sealing-wax, the leaves collapse. If we reverse the order, touching the knob with the rubbed sealing-wax first, the leaves diverge, and then collapse when the knob is touched by the rubbed glass rod. This experiment shows that, although both the glass and the sealing-wax rods become electrified by rubbing, the electrical conditions of the two bodies are opposite in character. When one makes the gold leaves diverge, the other makes them collapse. If instead of the gold-leaf electroscope we use the two pith-balls, we find that after they have been touched with the rubbed glass they repel one another and are also repelled on

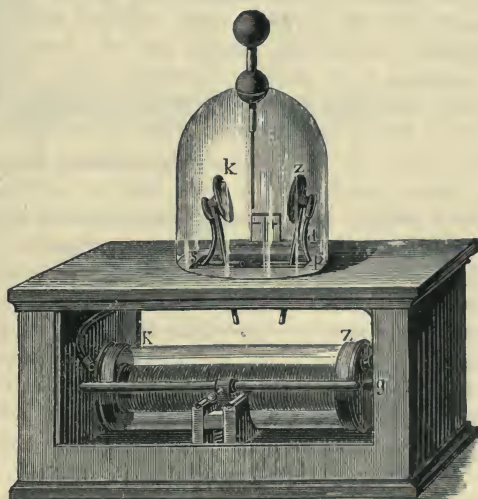

Fig. 42.—Behrens' Electroscope.

the approach of the rubbed glass. But if now the rubbed sealing-wax is brought near they are violently attracted by it. We distinguish, therefore, between two kinds of electrification; viz., that of the rubbed sealing-wax, which has been termed *resinous*, and that of the rubbed glass, which has been termed *vitreous*.

Further experiments show, however, that the nature of the electrification of bodies depends not only upon the bodies rubbed, but also upon the rubber. Therefore the electrical condition of a body is not sufficiently indicated by either of the above terms, and it has been agreed that the one kind of electrification should be termed *positive* and the other *negative*; the condition of glass rubbed with amalgamated leather represents the former, resin rubbed with wool the latter. Therefore positively electrified bodies are all those bodies that exhibit the same properties as a glass rod rubbed with amalgamated leather, and negatively electrified bodies all those which exhibit properties of the opposite kind. The phenomena observed, concisely stated, may, for the present, be stated thus:—1. *There are two kinds of electrification, positive and negative*; 2. *Bodies exhibiting the same kind of electrification rebel each other, while bodies charged with opposite electrifications attract each other.*

We shall, later on, adduce experiments to prove that these two kinds of electrification are produced simultaneously in equal quantities, and that the positive electrification of the rubbed body is matched, at the moment of generation, by an equal negative electrification of the rubber. Also that when equal quantities of positive and negative electrification are communicated to a body they neutralise one another, and the body does not change its electrical condition.

So far the phenomena are very similar to the corresponding phenomena in the science of magnetism, but there are several important distinctions which should be carefully noted. Thus, a magnet only attracts iron and one or two other magnetic substances, whilst a charged glass rod will attract all kinds of light bodies, and only becomes inoperative when the body experimented on requires larger forces to move it than are brought into play by the electrifications. Comparatively heavy bodies can be acted on if only sufficiently free to move. Thus a boxwood meter scale balanced on an inverted flask (Fig. 43) can readily be attracted by a piece of rubbed glass. Then again, a body can be charged with one kind of electrification only, whilst a magnet must have both north- and south-seeking poles. Further, the bodies (insulated conductors) which are most easily electrified by contact with the glass rod cannot be handled without losing all trace of electrification, whereas a magnet may be freely handled and will retain its magnetism for years. Other differences will appear as we proceed.

By means of the instruments already described, and employing these facts, we are enabled to examine the electrical condition of bodies, and to



ascertain which kind of electrification a body has. The method adopted with the gold-leaf electroscope is the following : The electroscope is first

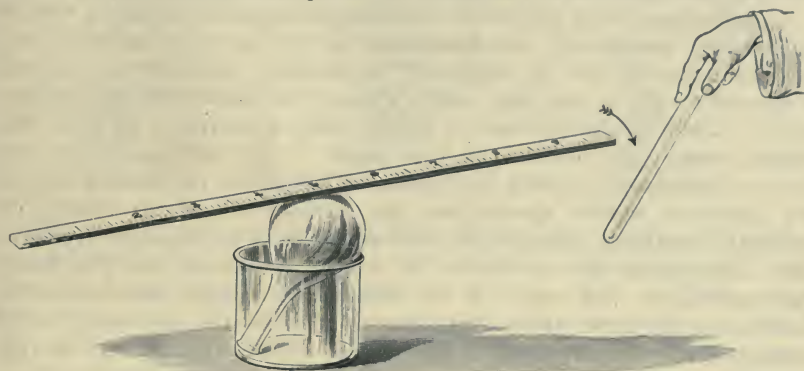

Fig. 43.—Electrical Attraction of a heavy body.

charged, say, positively, being touched with a glass rod rubbed with leather, causing the leaves to diverge ; then the knob is touched with the body under examination ; if the leaves diverge still further, the body is charged positively ; if the leaves partly or entirely collapse, the body is charged negatively. Care should be taken to ascertain whether the body is at all electrified, as the divergence of the gold leaves is lessened when a non-electrified body touches the knob, because some of the electricity of the gold leaves has been imparted to the body.

**Conductors and Insulators.**—If we suspend a pith-ball  $H_1$  (Fig. 44) by means of a silk thread, and a second  $H_2$  by means of a metal wire from the former, and touch  $H_1$  with a rubbed glass rod,  $H_1$  becomes positively electrified, and is consequently repelled by the glass rod ; and  $H_2$  is also repelled, although not touched by the rod. Further,  $H_2$  is attracted by a rod of sealing-wax, and is also able to attract light bodies. No charge of electricity has been imparted to  $H_2$  directly by contact with the glass rod, yet it shows the same properties as  $H_1$  ; hence it follows that electricity from  $H_1$  must have passed to  $H_2$ , or, in other words, that the metal wire *conducted* the electricity from  $H_1$  to  $H_2$ . If we suspend  $H_2$  from  $H_1$  by a silk thread instead of a metal

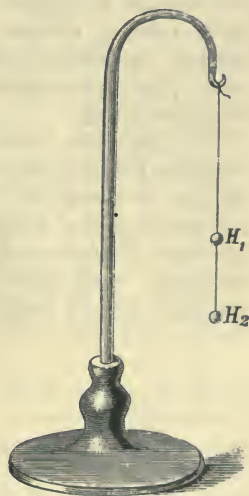

Fig. 44.—Electric Pendulum.

wire, and repeat the experiment,  $H_2$  will exhibit no sign of electrification, showing that the silk thread does not conduct electricity.

Again, if we touch the knob of a charged electroscope with a rod of unelectrified sealing-wax, the divergence of the leaves is lessened; but on examining the rod of sealing-wax by Behrens' electroscope, we find it electrified only at the place where contact was made with the electroscope. Other substances, such as metals, become electrified all over the surface when only touched at one point. These facts show that we have to distinguish between two classes of bodies, in the first of which the electricity rapidly spreads over the surface, and in the second of which the electricity only spreads over the body, if at all, at a very slow rate. The former class of bodies are termed *conductors*, and the latter *non-conductors* or *insulators*. If the knob of a charged electroscope be touched by the hand, the leaves collapse at once, the electricity being conducted, as we shall show in due course, by the human body to the earth. In order to find whether a substance is a good conductor of electricity or not, take the substance to be examined and touch the knob of the electroscope with it; if the leaves collapse immediately, the substance conducts electricity well. It may be proved by touching a second unelectrified electroscope that the substance retains no signs of electrification; this is because the electricity has passed from it through the human body, and hence to the earth. The time which the gold leaves take to collapse gives us a method of roughly ascertaining the relative conducting powers of substances. With metals this collapse takes place immediately, with resins more slowly, and with dry wood more slowly still.

We can draw no strict line of division between conducting and non-conducting bodies, since all substances offer a certain resistance to the passage of electricity, and there are none that absolutely stop it. In the following list, due to Riess, the names of the substances are arranged in order of conductivity and so that each conducts better than the next following. They are also classed as conductors, partial conductors, and insulators. More exact tables will be given later.

#### CONDUCTORS.

Metals.	Sea-water.	Parts of animals still
Charcoal.	Fresh-water.	having life.
Graphite.	Rain-water.	Soluble salts.
Acids.	Growing vegetables.	Linen.
Salt solutions.		Cotton.

#### PARTIAL CONDUCTORS.

Alcohol.	Dry Wood.	Straw.
Ether.	Marble.	Ice at 0° C.
	Paper.	

## INSULATORS.

Dry metal oxides.	Oils (etheral).	Silk.
Oils (fatty).	Porcelain.	Precious stones.
Ashes,	Dried vegetables.	Mica.
Ice at $-25^{\circ}$ C.	Leather.	Glass.
Phosphorus.	Parchment.	Wax.
Lime.	Dry paper.	Sulphur.
Chalk.	Feathers.	Resin.
Caoutchouc.	Hair.	Amber
Camphor.	Wool.	Shellac

Here, then, we have an explanation of the reason why in the earliest times, and even as recently as the time of Gilbert, many substances were considered incapable of electrification by rubbing. Bad conductors, such as amber, could be held in the hand without the electricity generated by rubbing being conducted to the earth. Metals, on the contrary, conducted the electricity produced, by means of the hand, to the earth. In order to electrify metals, or any other conductors, therefore, we must support them in some manner by an insulator. If they be held by glass handles, or suspended by a silk thread, they may be electrified by rubbing.

Gases at ordinary atmospheric pressures and under electric stresses which are not excessive are bad conductors of electricity; if it had been otherwise we should never have become acquainted with the phenomena of electrostatics, for the charge of electricity would have been conducted away by the air as fast as it was generated. Moist air will spoil the insulation of non-conducting supports. All bodies are more or less hygroscopic, and the moisture condensed on their surfaces thus causes the best insulators to behave as conductors, by giving rise to what is known as surface leakage. Change of temperature also influences conductivity; red-hot glass and molten resin, for instance, becoming good conductors.

**Electrics** was the name given by Gilbert to those bodies which he was able to electrify by friction. In order, then, to ascertain whether a body can be electrified or not, it is not sufficient merely to take that body in the hand and rub it; it should be carefully insulated first. When such precautions are taken we find that all bodies, without exception, can be electrified. The following experiments show that in the process the rubber also becomes electrified. In Fig. 45 A is a glass disc, B a disc covered with amalgamated leather; both being insulated by means of glass handles. If these two plates are rubbed together, each

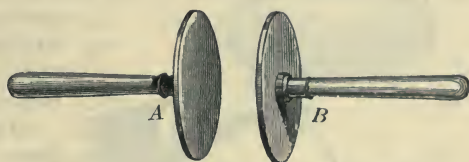

Fig. 45.—Insulated Discs.



of them becomes electrified, the glass plate positively and the leather negatively. If we change the glass for resin, and cover B with wool instead of leather, and then rub them together, the resin plate becomes negatively electrified and the wool plate positively. From these and similar experiments we learn that: 1. *All bodies may be electrified by rubbing*; 2. *Both bodies are electrified when rubbed, one of them positively and the other negatively*. 3. *The same substance may be either positively or negatively electrified by using different rubbers*.

The following list is so arranged that any substance in it becomes positively electrified when rubbed by any of the substances taking rank after it:—

+ Catskin or fur.	The hand.	Ebonite.
Wool.	Wood.	Resins.
Glass.	Sulphur.	Guttapercha.
Ivory.	Flannel.	Metals.
Silk.	Cotton.	— Guncotton.
Rock crystal.	Shellac.	

The position of some of the bodies in this list must not be regarded as invariable, for it depends on the particular specimen used and the state in which it happens to be.

**Distribution of Electrification.**—It is interesting to examine the distribution of the electrification on the surfaces of conductors which have been electrified, either by having been touched with rubbed glass or in one of the other ways we shall describe presently. Except in the case of that most symmetrical of all bodies, the sphere, the electrification is found to be unequally distributed, the distribution depending on the shape of the body. A good method of examining the distribution is by using a proof-plane and an electroscope or electrometer. The proof-plane consists of a thin disc *d* (Fig. 46),

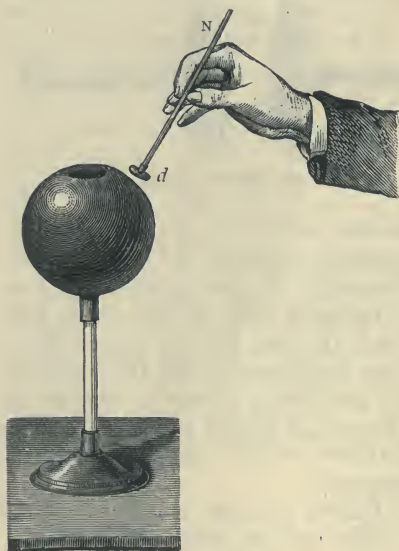

Fig. 46.—Proof-plane and Charged Sphere.

with a metallic surface, attached to an insulating handle *N*. The disc may be either flat or curved to fit the surface of the body to be examined. The body having been insulated and charged, the proof-plane is brought into contact with different parts of the surface successively. After each contact the disc is carefully removed in a direction at right angles to

the surface, and its electrification tested by means of an electroscope, or, better still, with an electrometer. The indications of the instrument measure more or less accurately the quantity of electrification removed from the charged body by the proof-plane, and as the area of the latter is constant, this quantity is a direct measure of the mean *density* of electrification over the part covered. For good results it is necessary that the body examined should be placed at a distance from all other conductors, and that means should be taken to keep its total charge constant, notwithstanding the small charges removed by the proof-plane. The insulation of both the charged conductor and of the proof-plane should be perfect.

One method of exhibiting the results obtained in a graphic form is to draw round a diagram of the body a dotted line whose distance from the surface of the body at each point is directly proportional to the electrical density as measured with the proof-plane. The results in four different cases are shown in Fig. 47. On the sphere *a* the density is everywhere uniform, as we might expect, and therefore the dotted line is everywhere equidistant from the surface. On the elongated ellipsoid *b* the density is much greater at the ends than on the flatter central zones, and this is indicated by the greater distance of the dotted line from the surface at the ends as compared with the central parts. The cylinder *c* with its rounded ends shows still more markedly the effect of the curvature on the density at these ends, but the end effect is traceable for an appreciable distance along the regular cylindrical surface. The last figure *d* is the section only of a thin circular plate. Here the effect of the sharp curvature round the edge is very striking, being much greater than on the flat portions of the plate. In fact, it may be stated as a general rule that the density varies with the curvature of the surface, being greater wherever the curvature is greater.

**Modes of producing Electrification.**—With the first method discovered in order of time, namely, friction followed by separation, we may associate other mechanical processes, such as cutting, filing, pressing, etc. etc. For instance, Iceland spar, when pressed with the hand, becomes electrified, and remains so for a considerable time. Electricity may be

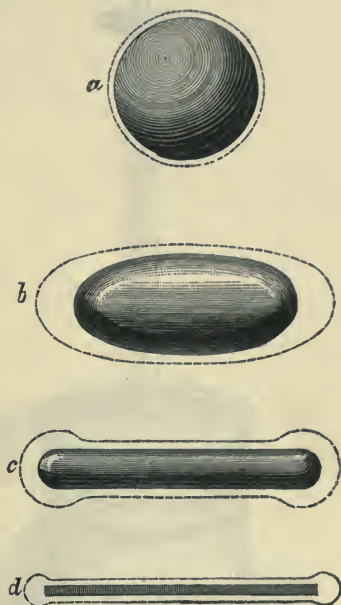

Fig. 47.—Density of Electrification.

produced by heating certain crystals, and is then sometimes called pyro-electricity. A good material for pyro-electricity is tourmaline; it remains unelectrified as long as it has the same temperature as surrounding bodies; but if it be heated or cooled, it shows two different electrical poles, opposite to each other, their states being easily tested by means of an electroscope. It is found that the pole which has positive electricity when heated will have negative when cooled. Tourmaline retains its electrical properties when powdered. Another mode of generating electricity occurs in the chemical process of combustion. It has been found that when bodies are slowly consumed by fire they themselves are negatively electrified, whilst the escaping smoke is positively electrified.

**Comparison of Charges of Electricity.**—It has been mentioned that the only evidence of a body's being charged with electricity is afforded by the force it exerts on other bodies. It is plain, therefore, that we must measure quantities of electricity by the relative forces which these quantities exert under similar conditions, and in order to do this we must ascertain the connection between the quantities of electricity and the forces they exert. To ascertain accurately the connection between the force exerted between two elec-

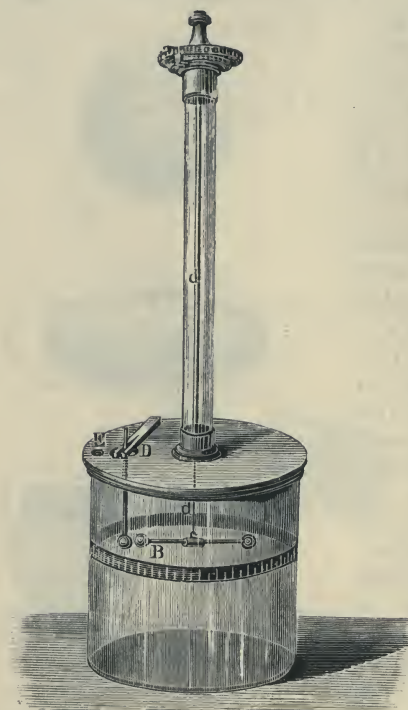

Fig. 48.—Coulomb's Torsion Balance arranged for Electrical Experiments.

trified bodies, Coulomb employed his torsion balance, a form of which, arranged for electrical experiments, is shown in Fig. 48. This instrument, as well as the principles on which it depends and the manner of employing it, have been described in its application to magnetism. A more carefully designed pattern, as constructed by Elliott Bros., for electrostatic work, is shown in Fig. 49. In both instruments the suspended magnet is replaced by light balls balanced at the extremities of a glass or shellac rod, as shown at B, and a similar ball attached to the end of a glass or shellac rod inserted at E replaces the fixed magnet. In Fig. 49 flat glass windows w w have been let into the cylindrical case to



increase the accuracy with which the positions of the enclosed balls can be observed, and the divided circle has been transferred to the top of the cylinder.

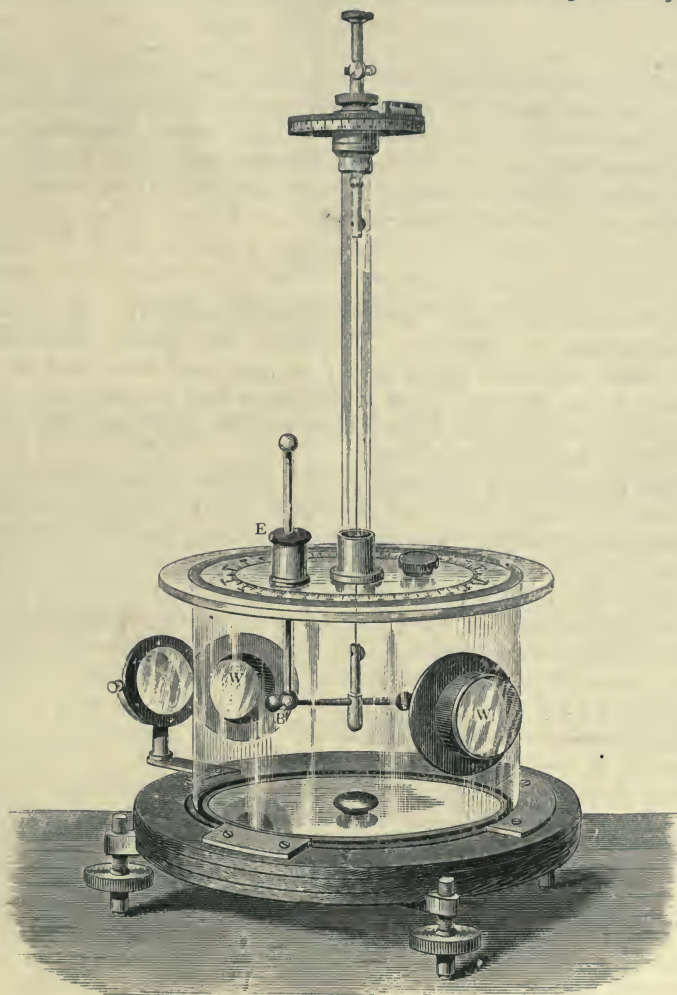

Fig. 49.—Coulomb's Torsion Balance (modern form).

By means of an arrangement of this kind Coulomb proved the fundamental law of electricity, namely, that "two small electrified bodies attract or repel each other with forces proportional to the amounts of their electrifications, and inversely proportional to the square of the distance between them."

If  $q_1$ ,  $q_2$  be the quantities,  $d$  the distance, and  $f$  the force, then

$$f = \frac{q_1 q_2}{d^2}$$

The above equation, however, does not express the whole of the facts. As we shall show presently, the medium across or through which the action takes place, and which was therefore called by Faraday the *dielectric*, has an important influence on the result, and therefore some term should be introduced recognising this influence of the medium. The more complete equation will therefore be—

$$f = \frac{q_1 q_2}{k d^2}$$

where  $k$  represents the "specific inductive capacity," as it is called, of the medium or dielectric. Coulomb's law should therefore run—*Two small electrified bodies attract or repel each other with forces proportional to the amounts of their electrification and inversely proportional to the square of the distance between them and the specific inductive capacity of the dielectric which separates them.*"

**Unit Quantity of Electricity.**—To measure quantities of electricity absolutely it is necessary to have some unit, and the definition of this unit is furnished from the above-mentioned law by making the two quantities equal, and the force, the distance, and the specific inductive capacity each unity. The unit, thus defined in terms of the fundamental units now universally adopted in scientific work, is the quantity of electricity concentrated at a point which is capable of repelling a similar quantity of electricity at another point at the distance of one centimetre in air with a force of one dyne—that is to say, with a force which would give a mass of one gramme a velocity of one centimetre per second in one second. As it is impossible to concentrate electricity at a point, we may use two small balls of similar dimensions, the distance in centimetres being measured approximately from centre to centre. The torsion balance, however, only proves this law approximately, because of practical difficulties and small disturbances not easily overcome or allowed for. But the law has been proved by indirect methods to a very high degree of accuracy, and therefore can be accepted as experimentally demonstrated.

One of the greatest difficulties in using the torsion balance is the leakage of the charges from the bodies experimented on. If we charge the balls and observe the angle of separation, we find that when the instrument is left in the same position for some time this angle becomes smaller and smaller. As the force of torsion does not alter, there must be some waste of the charge. How is this waste to be explained? The balls are surrounded by air, and are fastened to insulators; so that the electricity may escape by the air, or by the insulators, or by both. Experiments have shown that there is leakage in both directions. Electrified bodies attract small dust

particles in the air, electrify them, and then repel them; in this manner the original quantity of electricity is diminished. Moreover, there are no perfect insulators; electricity is conducted, though very slowly, through, or over the surface of, the best insulator. To what extent the electricity will spread over the insulator depends upon the amount of electricity the body itself contains. The amount of electricity on the insulator diminishes with the distance, being densest near the charged body. If there be dust or moisture on the insulator the electricity will be conducted away rapidly. To prevent the condensation of moisture glass insulators are often coated with a thin layer of shellac. There is, however, an objection to this remedy, as particles of dust stick to the shellac, and are not so easily removed. A better method is that adopted by Professors Ayrton and Perry, who place their insulators in closed or nearly closed glass vessels with strong sulphuric acid, or some other desiccating agent, exposed in a convenient separate receptacle inside the closed space.

## II.—THE ELECTRIC FIELD.

The law of electric force obtained from Coulomb's experiments is identical in mathematical form with the law of magnetic force previously obtained (page 27) from similar experiments with magnets. There follows, therefore, the same necessity in electric as in magnetic problems for considering and taking into account the action of the medium, and much that we have written on this and cognate points might be re-written here almost word for word with the substitution only of electric for magnetic terms. We do not propose, therefore, to repeat the arguments set forth on pages 29 to 34, but we ask our readers to bear them in mind in what follows, and to apply them *mutatis mutandis* to the analogous electrical cases.

To Faraday again must be ascribed the honour of first suggesting that the actions taking place in the dielectric medium should be represented both as to magnitude and direction by lines of force. Such actions exist within the space to which the influence of any charged or electrified body or system of bodies extends, and this space is known as the *electric field*.

The existence of this electric field is due to electric strains set up in the medium, or *dielectric*, as Faraday called it, during the process of electrification of the conductors, just as the existence of the magnetic field is due to magnetic strains in the medium. The strains consist of a tension along the lines of force and a pressure at right angles to them. In the magnetic case we have a ready method of showing graphically the general trend of the lines of force by means of iron filings. Unfortunately there is no method so readily applicable in the electric case, but the following experiment devised by Faraday is suggestive.

A glass tank was nearly filled with turpentine which had floating in it a number of short pieces of dry silk fibre. Two wires were passed through the vertical ends of the tank opposite one another, and one was connected to a



source of electrification, the other being joined to earth by a chain. When the insulated wire was electrified the pieces of silk formed up into quivering chains of particles along the lines of force, but as soon as the electrification disappeared they broke up again and all trace of regular arrangement disappeared.

In 1875 Dr. Kerr, of Glasgow, examined the state of certain transparent liquid dielectrics by means of polarised light, and proved that the material of the dielectric was in a state of strain. Without going deeply into the optical arrangements necessary, it may be explained that it is possible to polarise a beam of light and thereby to cause all the vibrations of

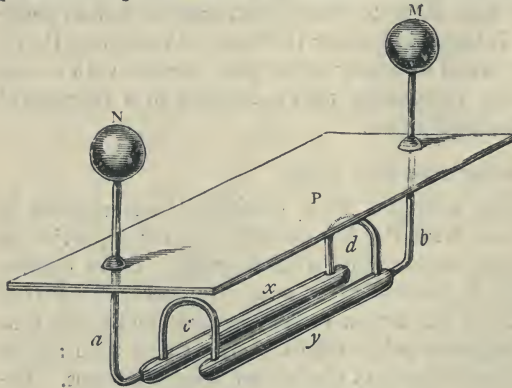

Fig. 50.—Experiment on Electrostatic Strain.

which it consists to be executed in one plane. A Nicol's prism consists of Iceland spar so arranged that no light vibrating at right angles to a certain plane can get through. It is therefore possible to place the prism in the path of a beam of plane polarised light in such a way that no light passes through the apparently transparent prism, and what is known as a dark field is produced. If, however, the plane polarised beam, after leaving the polariser and before reaching the analyser (the Nicol's prism), is at all changed as regards the direction of vibration of the waves, some of the light will get through the analyser and the field will be no longer dark. One well-known way of effecting such a change is to pass the light through a non-crystalline transparent solid (*e.g.* glass) and then subject the solid to mechanical strain. The resultant field, dark before the application of the strain, is at once illuminated when the strain is applied.

We are now in a position to describe one or two of Dr. Kerr's experiments as repeated and modified by Professor Rucker in 1888. The dielectric used was bisulphide of carbon contained in a glass tank, special precautions being taken to minimise the danger from leakage of this rather inflammable liquid. Two long metallic cylinders *x* and *y* (Fig. 50\*) were mounted parallel to, but insulated from, one another, so that they could be readily immersed in the dielectric. They were suspended from the glass plate *P* by the metal rods *a* and *b*, and were kept at a fixed distance apart by the glass arches *c* and *d*; the balls *M* and *N* acted as terminals. In the experiment the beam of plane

\* Figs. 50 to 54 are reproduced by kind permission of the publishers of *The Electrician*.

polarised light was passed through the tank between the cylinders, parallel to their axes, and was examined by the analyser on emerging from the tank. With the cylinders unelectrified the analyser was set to give a perfectly dark field. One cylinder was then electrified positively and the other negatively, with the result that the effect shown in Fig. 51 appeared on the screen. The space between the cylinders, which, being seen end on, appear as spheres, was brilliantly illuminated, the rest of the field remaining dark. The effect is the same as that which would have been produced by passing the light through a transparent solid mechanically strained.

In another experiment two metallic plates  $x$  and  $y$  (Fig. 52) were bent so that when seen end on they resembled the section of a Leyden jar, the resemblance being increased by attaching a wire and a ball to the inner plate. The polarised light being passed



Fig. 51.—Electric Strains between two Charged Cylinders.

between the plates and the field darkened before electrification, the effect shown in Fig. 53 appeared as soon as the plates were oppositely electrified. When two *concentric* cylinders are used the effect produced on electrification is depicted in Fig. 54. By further and still more beautiful optical tests, the description of which would make too great a demand on our space, it can be shown that the results obtained are such as could be predicted from Maxwell's theory that the dielectric strain consists of a tension along the lines of force and a pressure at right angles to them.

The *intensity of the field* at any point is defined as the electric force with which the field would act upon a unit charge of electricity placed at the point, it being postulated that the presence of this charge is not to disturb the existing field. If, therefore, a body electrified with ( $q_2$ ) units



Fig. 52.—Leyden Jar Model.

be brought to a point of the field where the intensity is  $I$ , the actual force ( $f$ ) is

$$f = q_2 I$$

Comparing this with Coulomb's equation,

$$f = \frac{q_1 q_2}{k d^2}$$

we get

$$q_2 I = \frac{q_1 q_2}{k d^2}$$

and therefore

$$I = \frac{q_1}{k d^2}$$

which gives the intensity of the field due to a single charge  $q_1$  in a dielectric of specific inductive capacity  $k$  and at a distance  $d$  from the charge.

Following our rules (page 36) for drawing lines of force, the field set up by such a charge supposed distributed over a small sphere would be

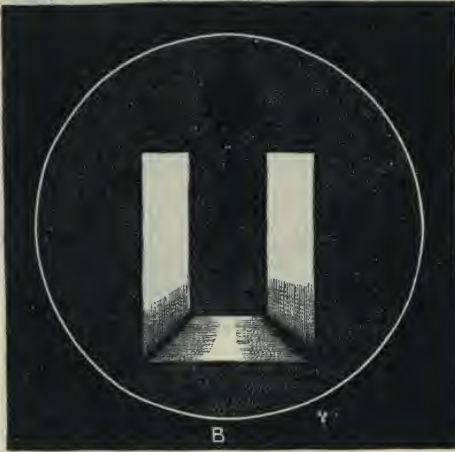

Fig. 53.—Electric Strains shown by Leyden Jar Model.

as represented in Fig. 55. All the lines start from the surface of the sphere, and proceed outwards in radial directions. The actual number to be drawn according to the rules can be readily determined by supposing a sphere of unit radius (1 centimetre) to surround the charged sphere as shown by the dotted circle. The intensity of the field ( $I_1$ ) at all points of this surface is

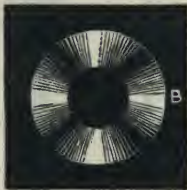

Fig. 54.—Electric Strains between Concentric Cylinders.

$$I_1 = \frac{q_1}{k} \quad \text{since } d = 1$$

and the lines must be so drawn that this number  $\left(\frac{q_1}{k}\right)$  crosses each square centimetre of the sphere. But the area of the sphere in square centimetres is  $4\pi$  (i.e.  $4\pi r^2 = 4\pi$ , since  $r = 1$ ), and therefore the total number of lines required is

$$N = 4\pi I = \frac{4\pi q_1}{k}$$

This number  $N$ , it must be remembered, is the *total* number of lines to be drawn outwards from the small sphere, and not merely the number in the plane of the paper as represented in the figure. The small sphere is supposed to be positively charged, hence the arrows denoting the direction of the lines are directed outwards, for the rule is that *the*



*direction of a line of force is that in which a positively charged body would tend to move along it.* In the case represented the positively charged body would be repelled by the positively charged sphere, hence the lines are directed outwards. Conversely, had the sphere been negatively charged the lines would have run towards it.

The distribution on the surface of the sphere being uniform it is comparatively easy to draw the lines of force in the space immediately

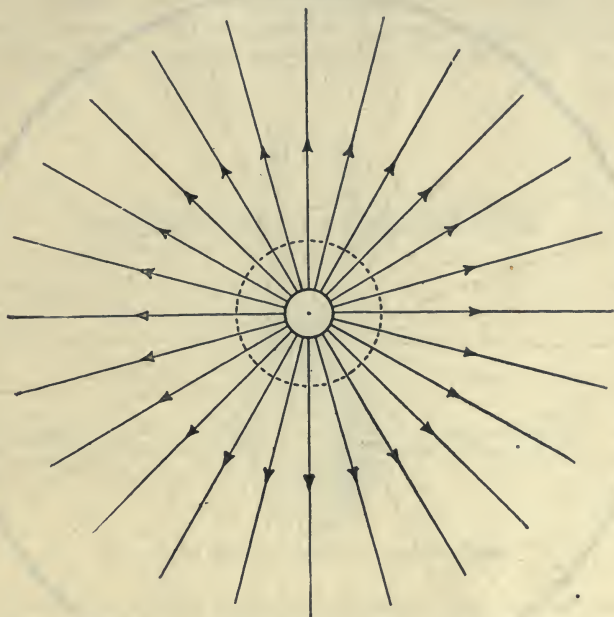

Fig. 55.—Lines of Force of a Charged Sphere.

surrounding it. In other cases where the distribution is less uniform, as, for instance, those shown in Fig. 47, the problem becomes more complicated. But when we consider how the lines of force must tend to run, we see why it is that the density of the electrification is greatest where the curvature is sharpest. In the first place, we must remember that the lines of force must leave the surface of a conductor at right angles to it. Now suppose the long cylinder with hemispherical ends, *c*, Fig. 47, to be placed (Fig. 56) at the centre of a sphere so large that for all practical purposes the inner surface of the sphere is equidistant from all parts of the cylinder—in other words, the sphere is to be infinitely larger than the cylinder. If it be supposed that in Fig. 56

the size of the cylinder B has been exaggerated about 100 times as compared with the sphere represented by the large circle  $a b h d c g$ , some approximation to the conditions will be realised. The lines leaving the cylindric surface of the cylinder in the plane of the paper, if they travel straight forward without curving, will all fall on the sphere between

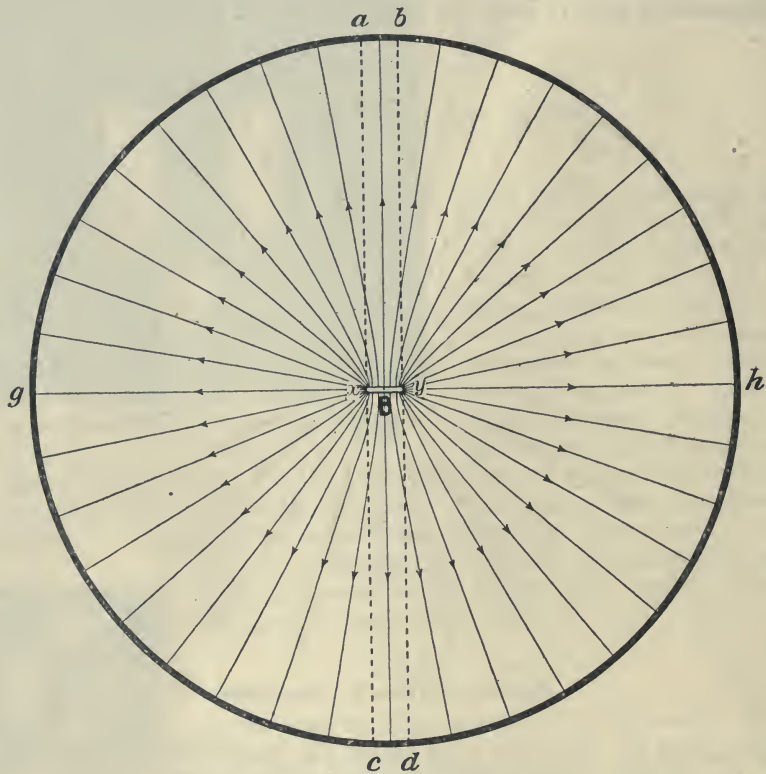

Fig. 56.—Lines of Force from Charged Cylinder.

$a$  and  $b$  for the upper surface and between  $c$  and  $d$  for the lower. Those leaving the curved end  $x$  will, under the same conditions, fall on the part  $a g c$  of the sphere, whilst those leaving the curved end  $y$  will fall upon  $b h d$ .

At the surface  $a h d g$  of the sphere the field which all these lines represent is practically uniform, because of its great distance from B, and therefore the lines will be equally distributed at this surface and will be radii of the sphere. At the surface of the cylinder they are perpendicular to that

surface. Combining these two conditions we see that although the lines will not be perfectly straight when close to the cylinder, yet on the whole many more *must* proceed from the hemispherical ends than from the cylindrical surface. The fact is that the lines from the ends represent strains in a region of space very much larger than that which receives lines from the cylindrical surface, and therefore they are much more numerous. In the figure a few of the lines are drawn, but even with these few it is difficult to draw the positive ends at the cylinder accurately, because of the small though exaggerated scale upon which the cylinder is shown. When it is remembered that the end of each line on the

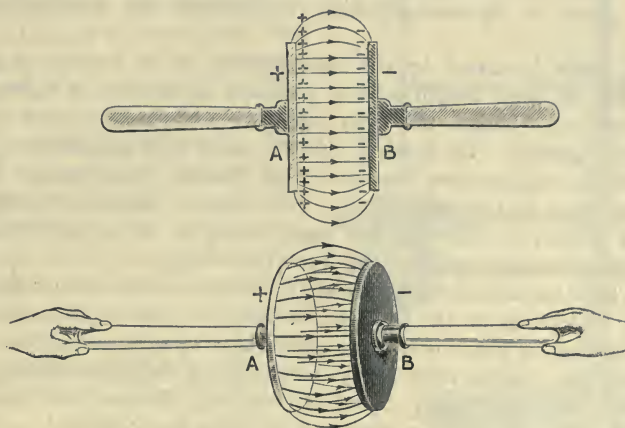

Fig. 57.—Strain Lines between rubbed and separated Discs.

cylinder represents a definite charge of electricity, the unequal distribution of the charge, as shown in *c*, Fig. 47, is fairly well accounted for.

**Electrification.**—We must now consider more closely the method of producing electrification by the process of rubbing dissimilar bodies together and then separating them. To get rid of any complication which might arise if the rubber were held in the hand, we take the case of Fig. 57, where the glass disc *A* and the leather-covered disc *B* are mounted on and held by insulating handles. If the discs *A* and *B* be rubbed together, *but not separated*, no signs of electrification can be detected by the most sensitive tests that can be applied. But if the discs be drawn apart a little distance the space between them is found to be an electric field, and as they separate farther and farther electric forces will be found to exist in more and more of the surrounding space.

The following points may be remarked on here:—

1. As the discs are being separated they are attracting one another,



and therefore *work has to be done* in drawing them apart. What becomes of the energy thus used? The answer is that it is stored as strain energy in the dielectric. Just as in the magnetic field so in the electric field, as Dr. Kerr's experiments show, the medium is strained and energy is required to produce this state. We now see where this energy comes from—namely, from the work done by the agent who drags the rubbed body (A) and the rubber (B) asunder. To separate the  $+$  and  $-$  electrifications work must be done and the equivalent energy is stored in the medium. This energy is therefore sometimes called the *energy of electrical separation*. Note carefully that it is not the work done in *rubbing* (which merely produces frictional heat) but the work done in *separating* which determines the electrical energy stored.

2. The stress indicated by the lines consists of a tension or pull in the direction of their length and a pressure or thrust at right angles to that direction. Hence the lines always *tend to contract and to repel one another sideways*. By bearing this in mind it is possible to indicate qualitatively the approximate direction of the lines in many cases. Thus in Fig. 57 the lines at the edges of the discs tend to bulge outwards. For clearness a section of the discs has been drawn in the upper part of the figure showing the lines in the plane of the paper only.

3. The lines begin and end at the electrifications or charges of electricity. In one way of looking at the phenomena these charges may be regarded as simply indicating the places where the electrical stresses cease to exist. As far as we know these charges must always be associated with gross matter, that is, the lines of force cannot begin or end on nothing. We see that this follows at once if the lines have to be generated by some such method as that set forth above.

4. With each line is associated a definite quantity of  $+$  electrification at one end and an equal quantity of  $-$  electrification at the other. Therefore the quantities of  $+$  and  $-$  electrification *must* be equal and one cannot exist without the other.

The consideration of what happens when the discs are still further separated will be resumed after we have dealt with some of the phenomena of electric induction.

### III.—ELECTRIC INDUCTION.

It can be shown experimentally that the presence of an electrified body is sufficient to produce signs of electrification in a neighbouring conductor, although there is no conductor between them to bring them into electrical contact. For this purpose Riess used the apparatus represented in Fig. 58. The stand *f* has three movable arms, the middle portion of each consisting of glass. The highest arm holds a brass rod, or hollow cylinder, neatly

rounded at its ends, and with pith balls at different places suspended by means of thin metal wires; the middle arm supports the glass plate *d*, and the lowest arm the brass ball *e*. The rod *a b* is in a line with the centre of this brass ball. The three arms are so arranged that all the parts are near to each other, but are not in contact. Immediately the ball *e* is charged, the rod *a b* also becomes electrified. This is manifested by the repulsion of the pith balls at the two ends. The ball *e* and the rod *a b* do not electrically touch one another, being separated by the glass plate *d*. It is evident, therefore, that *e* influences *a b* through the intervening medium. Electrification, when produced in this manner, is said to have been caused by *induction*. By placing the pith balls at different heights we may prove that the electrical action on *a b* is greatest at its ends. If we move the pith balls along the rod, we find that at a point near the middle of the rod there is no repulsion, and we conclude that the electrification there is naught. If now we examine the electricity on the two ends of *a b*, we find that the electrical condition at *a* is opposite to that of the brass ball *e*, and the electrical condition at *b* opposite to that of *a*. The point at which there is no sign of electrification is not quite in the middle of rod *a b*, being nearer *a* than *b*. The influenced body retains its electrification only so long as the ball *e* is not withdrawn. We can, however,

permanently charge *a b* by simply preventing the two charges from re-uniting. Let *a b* consist of two parts and suppose *e* to be positively electrified. On bringing *e* near *a b* the latter will come under induction, and negative electrification will be found on the lower half and positive on the upper part of *a b*. If now the two parts are separated from each other, *e* may be removed also, or discharged, and yet the two parts of *a b* will retain their charges. The parts *a* and *b*, of course, must be well insulated as regards the rest of the apparatus. Negative electrification only is obtained when *a b* is connected for an instant with the earth, the connection being removed before the removal of the influencing charge on *e*.

To examine the effect of placing an insulator in the electric field of a charged body, the brass rod or cylinder *a b* must be replaced by some insulator—for instance, a shellac rod. If the ball *e* is positively electrified, the

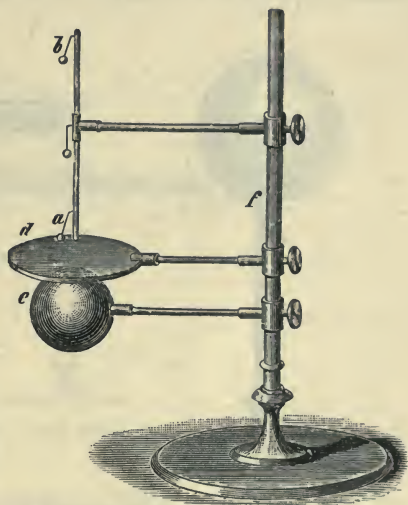

Fig. 58.—Riess' Induction Apparatus.

shellac rod on the near end (that is, the end nearest the ball *e*) will be found to be negatively electrified. The difference between good conductors and good insulators is, however, very marked. Conducting bodies when brought near an electrified body are at once influenced, but return to their ordinary state at once on the removal of the charged body; with non-conducting bodies both processes take a considerable time and the effects are less.

Another and more sensitive way of examining the phenomena is by means of the proof-plane whose method of use we have already explained. For this purpose the apparatus shown in Fig. 59 is convenient. The insulated sphere *K* is charged, let us suppose, positively, and the insulated

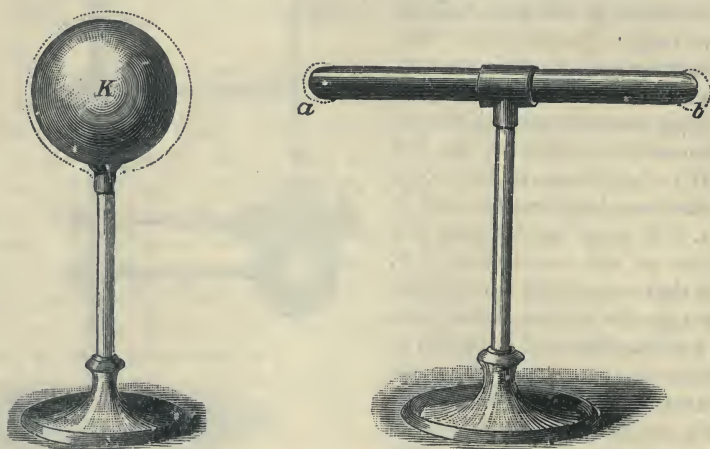

Fig. 59.—Insulated Conductor under Induction.

cylinder *a b*, which is uncharged, is placed near it. On examining the condition of *a b* with the proof-plane negative electrification will be found on the end *a* nearest to the sphere *K*, whilst positive electrification will be found on the end *b* farthest from *K*. The distribution will be approximately that indicated, according to the system explained on page 61, by the dotted lines at each end. If the sphere *K* be also examined in the same way, it will be found that the distribution is no longer uniform as in Fig. 47, *a*, but that there is a distinctly greater density on the side nearest to the cylinder, and that the density elsewhere is perceptibly diminished. This change is also indicated by the dotted line round the sphere.

The investigation enables us to draw approximately, with the assistance of our previous rules, the lines of force for the charged sphere and the cylinder under induction near it. The result will be as shown in Fig. 60, in which the lines in a central vertical plane only are drawn. The negative



electrification on the end  $a$  of the cylinder indicates that a certain number of lines end there, whilst the positive electrification on the  $b$  end similarly indicates that an *equal* number of lines set out from that end. Remembering the somewhat similar magnetic case, it might be supposed that all the lines that enter at  $a$  pass through the material of the cylinder and emerge at  $b$ , as they would do if  $ab$  were a piece of iron under induction. But this is not so. It is one of the fundamental properties of a conductor that it yields instantly to the smallest electric force, and that no electric force can be permanently maintained within the substance of a conductor in which no current is passing. There can, therefore, be no electrostatic strain and no

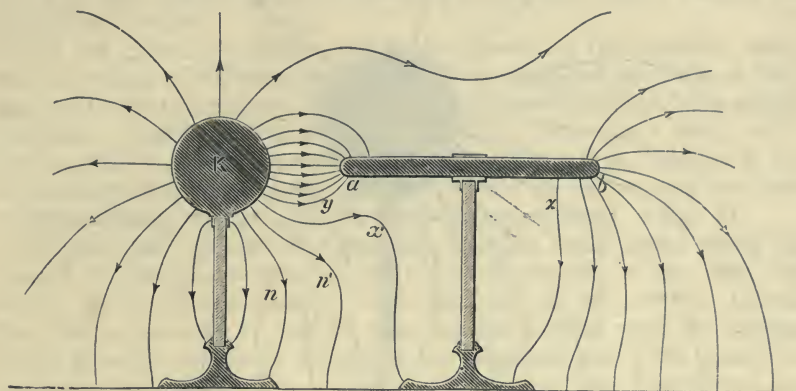

Fig. 60.—Lines of Force of Conductor under Induction. |

lines of force within the material of a conductor when the electric field has become steady. Hence the lines starting from  $b$  are entirely distinct from those ending at  $a$ . The two sets are equal in number because no charge has been given to the cylinder, either positive or negative, and therefore the sum of all the positive electrifications (or the lines starting from  $b$ ) must be equal to the sum of all the negative electrifications (or the lines ending at  $a$ ). In all nine lines have been drawn at each end of the cylinder, leaving thirteen lines emanating from the sphere which do not run on to the cylinder.

If now the cylinder be withdrawn to a distance from  $\kappa$ , it (the cylinder) will be found to show no signs of electrification, whilst  $\kappa$  will be restored to its original condition, which will be something like what is shown in Fig. 61, where the twenty-two lines emanating from  $\kappa$  in Fig. 60 are found to be still attached to  $\kappa$ , but their negative ends are now on the table and the distant walls, etc., of the room; all these ends, therefore, cannot be shown in the figure. Because of the greater proximity of the table, which may

be regarded as a conductor, the greater number of lines are drawn from the lower surface of the sphere, where the surface density, if tested by a proof plane, will be found to be greater than on the upper surface.

We can mentally form a picture of how the lines get back to their original position if we follow in detail what must take place as the cylinder *a b* (Fig. 60) is being withdrawn. In doing this it must be borne in mind that the ends of the lines are perfectly free to move over the surfaces of

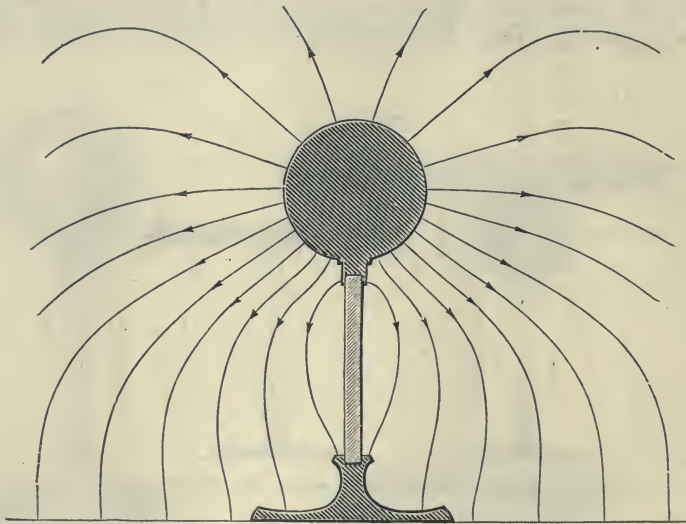

Fig. 61.—Lines of Force of Charged Sphere.

conductors and that when at rest all lines must leave such surfaces at right angles.

The — end of the line *x*, if *a b* were moved a little to the right, would slip off the foot of the stand and move a little to the left along the table, whilst the hump at *x* would be flattened, the line would contract and become somewhat straighter. The two lines *n* and *n'* to the left of *x* would be affected similarly, losing some of their special curvature and moving to the left. The lines on the left of them would also move towards the left.

Simultaneously the line *y* would be stretched by the movement of its — end to the right, this being the cause of the movement in *x*, which gets pushed down by the advancing *y* line. At the same time the + end of *x* is being drawn to the right, whilst the stand is slipping under its — end, which will tend to follow the retreating — end of *x*. A moment will eventually arrive when the lines *y* and *z*, but especially the latter, will become

quite unstable, the  $+$  end of  $x$  will slip along the cylinder and snap on to the  $-$  end of  $y$ , the two leaving the cylinder and forming a continuous line entirely in the dielectric, of a shape somewhat similar to  $x$  in Fig. 60, but having at first a more decided hump.

The  $+$  ends of the eight lines left on the right will now be found to have moved round the  $b$  end of the cylinder in a clockwise direction, whilst the  $-$  ends of the eight lines still terminating at the  $a$  end will be found to have slightly moved round that end in a counter-clockwise direction. Also the  $+$  ends of all the lines on  $\kappa$  will be found to have moved in a clockwise direction, some more than others, and so that the distribution on  $\kappa$  is now slightly more symmetrical round the central vertical line than it was before.

As the cylinder is further and further moved to the right the movements detailed in the last three paragraphs are repeated, the lines at the  $b$  end one by one joining on to the corresponding lines at the  $a$  end in the manner described. Finally all the lines will disappear from the  $b$  end, and it follows that with the disappearance of the last  $b$  line the last  $a$  line must simultaneously disappear and the cylinder be left without any trace of electrification, the final field of  $\kappa$  being that depicted in Fig. 61.

If now the cylinder be gradually brought back again along the line of its previous retreat, all the above movements of the lines will occur in the reverse order. The reader should go carefully through the reverse process, so that he may become familiar with the changes which occur in the field in this simple but important case. He should not neglect to notice that the first effect of bringing the conducting cylinder into the more distant parts of the field is to produce a deformation of the lines of force there even before a measurable quantity of electrification can be detected on the cylinder. The fact is that, looked at from this point of view, a conductor in the field appears to act as a weak spot or hole in the dielectric. This can be readily seen by comparing Figs. 60 and 61, for the strain lines evidently yield in the direction of the cylinder and are drawn towards it as if its presence were causing the state of strain to break down in its neighbourhood. With this further key many interesting problems can be solved. It is also important to note that the movements of the ends of the lines on the cylinder connote *electric currents* in the cylinder, a point to which reference will be made later.

**Electrification.**—We are now in a position to resume our consideration of the process of charging the two discs represented in Fig. 57. So far we have assumed that there are no conductors in the neighbourhood of the discs, and in this case all the lines starting from  $A$  will end on  $B$ . But in the actual case conductors, some of them very large ones, are near at hand; for instance, the body of the experimenter who is drawing the discs apart is such a conductor, or if they are being drawn apart by mechanical means the great conducting mass of the earth is not



far distant. These conductors, as we have just seen, act as holes in the dielectric, and their presence begins to make itself felt as soon as the rubbed bodies are fairly separated.

Let *c* (Figs. 62 and 63) represent the part of some large conductor nearest to the separating discs *A* and *B*, which are represented as drawn farther apart than they are in Fig. 57. In Fig. 62 the lines of force, though yielding in the direction of the conductor *c*, have in no case actually reached it. In Fig. 63, however, five of the lines of the preceding figures have touched *c* and snapped asunder, forming two groups

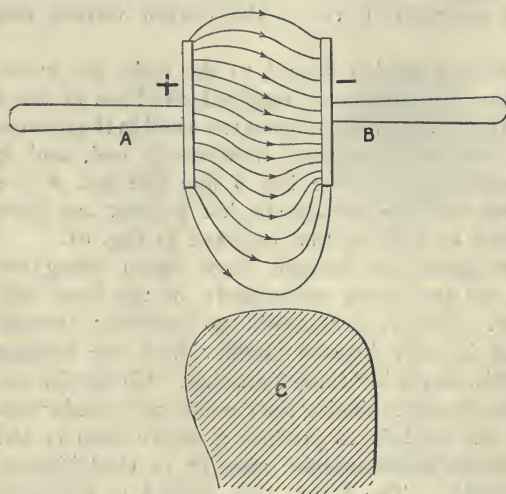

Fig. 62.—Effect of Neighbouring Conductor on an Electric Field.

of lines; one of these groups starts from *A* and ends on *c*, whilst the other starts from *c* and ends on *B*. The remaining ten of the original lines still begin on *A* and end on *B*, but their paths have been considerably changed. The three figures should be carefully compared.

In the last two figures there is a want of symmetry about the lines, due to the fact that one of the discs, *A*, is an insulator and the other, *B*, a conductor. The electrifications on *B*, that is, the ends of the lines of force, are free to sweep over the surface to any position required by the changing external circumstances. On the other hand, the electrification of *A* is quasi-rigid, and can only yield very slowly and slightly to the electrical forces. It will be noticed that the ends of the lines on *A* retain almost the original positions of Fig. 57, whilst those on *B* have changed considerably. Moreover, the lines leave *A* at all kinds of angles, showing that the electric forces have components parallel to the surface; but the lines falling on *B* all fall perpendicular to the surface, it not being possible for a line at rest to meet a conductor at any angle which would give a component along the surface.

It is easy now to follow the further process of separation. The remaining ten lines will one after the other strike *c* and divide into two lines, until finally no line beginning on *A* will end on *B*. The charges on *A* and *B* will now be separate and independent, each with,

its own electric field, and, whilst the discs are kept insulated, these charges can be moved about at pleasure; the ends of the line on *c* and other earth-connected conductors will follow the discs in their motions as may be necessary. The distribution on *A* will be fairly rigid whatever position it be placed in, but that on *B* will continually adapt itself to the position of neighbouring conductors.

We have dealt with this simple case in great detail because it is a typical one and incidentally touches most of the chief points involved. We now leave the reader to apply the principles to other simple cases. The one in which during the process of separation the conducting rubber is held in the hand, and therefore is always earth-connected, will present no difficulty.

### Electricity on Conductors.—

From the preceding it will be obvious that, on conductors, the electrification or electricity, that is, the ends of the lines of force, when at rest can reside only on the surface, for no line of force can penetrate a conductor. This, which is

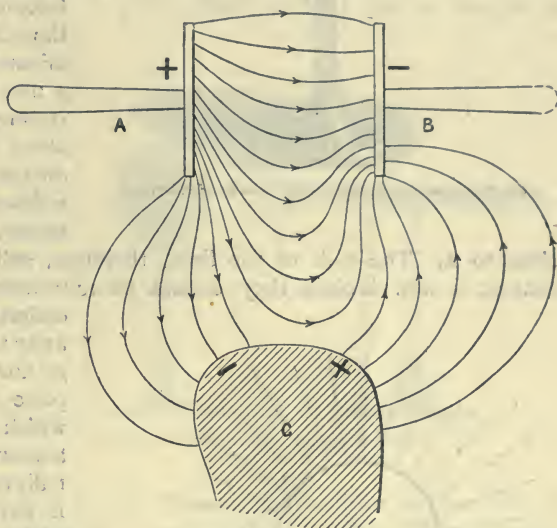

Fig. 63.—Effect of Neighbouring Conductor on an Electric Field.

so obvious when we consider the dielectric, is not so clear when the old fluid theories are followed. It is an important point, however, and worthy of experimental examination. For this purpose the apparatus shown in Fig. 64 may be used. The brass ball *A* rests on a glass rod, and can be accurately covered by the conducting hemispheres *B* and *C*; both hemispheres have insulating handles. Cover *A* by means of *B* and *C*, and charge the apparatus; after the removal of *B* and *C*, *A* shows no sign of electrification, whilst *B* and *C* remain electrified. The experiment is more striking if performed by first charging *A* and then placing *B* and *C* over it. The electricity that was at first on the surface of *A* passes to the surface of *B* and *C*, and can be removed with them, leaving *A* completely discharged. The part played by the dielectric

in these experiments can easily be traced by the aid of previous explanations.

**Theory of the Proof Plane.**—The above experiment also illustrates the theory of the proof plane. When the thin

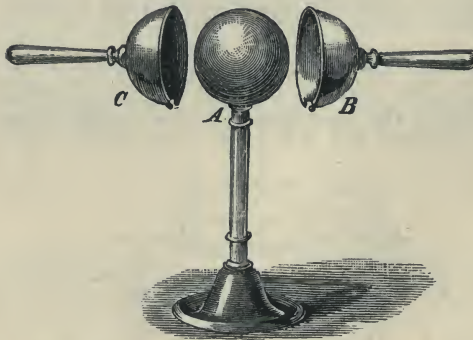

Fig. 64.—Conducting Sphere and Movable Hemispheres

plate  $p$  of the plane, held by its insulating handle  $h$ , is brought into close contact with the electrified surface of an electrified conductor, as shown in section in Fig. 65, the presence of the thin piece of metal does not disturb the lines of force of the field, except that those lines which formerly terminated on the surface under  $p$  now terminate on  $p$ . As  $p$  is moved off from the surface along the normal (or perpendicular) all parts of  $p$  break contact with  $A$  at the same instant whilst still  $p$  is very

close to  $A$ . The ends of the lines, therefore, still remain on  $p$ , but as contact is now broken they cannot be re-transferred to  $A$  through the dielectric. As  $p$  moves further away the field closes in behind  $p$ , and other lines take the place of those removed by  $p$ , which is now charged with the amount of electrification originally residing on the spot which it covered whilst in contact with  $A$ . The charge so removed can be measured by methods to be presently described.

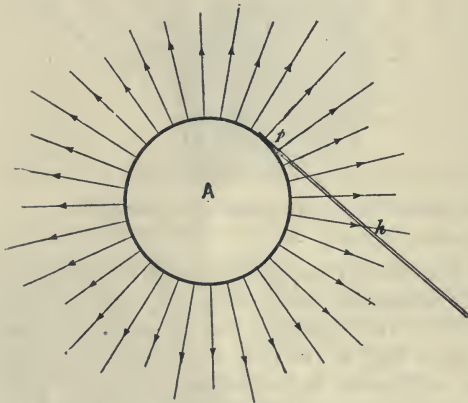

Fig 65.—Theory of the Proof Plane.

is unchanged. Further consideration of Fig. 60 will show that this must be so. As the cylinder  $a b$  is brought nearer and nearer to  $\kappa$  more and more of the lines from the latter fall on the  $a$  end, the number starting from the  $b$  end increasing *pari passu*. The lines passing from  $\kappa$  to  $a$  get

#### Electrification by Contact of Conductors.

—When an uncharged insulated conductor is brought into contact with a charged conductor it is found that both are electrified, but that the total charge



shorter and shorter, until finally they become concentrated in a very short gap, and a moment later disappear either at or before contact. But the number of lines so disappearing is exactly equal to the number of new lines which have been forming at the  $b$  end; so that eventually, when the two bodies are in contact, the number of lines emanating from the now compound conductor is exactly equal to the number which originally emanated from  $\kappa$  alone. The total charge is therefore unchanged, but it is important to note that such sharing of electrification by contact is always preceded by inductive action.

**Discharging a Conductor.**—If, however, the conductor  $a b$  be connected to earth by a wire  $c$  (Fig. 66) then no lines can be formed at the  $b$  end, for the

— ends of the lines ending on  $a$  reach their position by sweeping along the wire  $c$ . One of the lines  $x$  is shown in the process of being transferred, and it is evident that as the line contracts the — end must move up on to the cylinder until the repulsion of the neighbouring line  $y$  stops further motion. Finally,

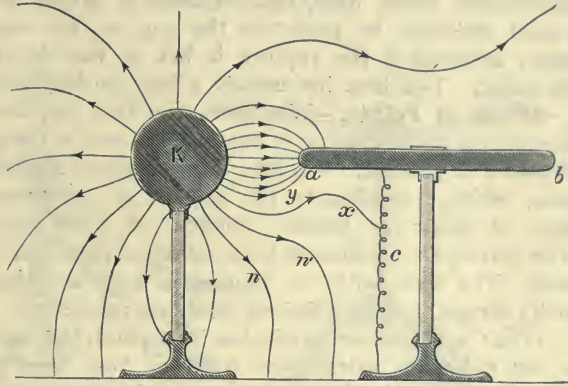

Fig. 66.—Earthed Conductor under Induction.

when  $a b$  gets very close to  $\kappa$  the — ends of the *whole* of the lines of  $\kappa$  will have been so transferred to  $a b$ , and when these lines disappear, in the manner just described,  $\kappa$  will be completely discharged and all signs of electrification will disappear. It will be seen, therefore, that the process of discharging a conductor by bringing up to it an earth-connected conductor is always preceded by inductive action on the latter.

**Electric Current on Discharge.**—The sweeping of the negative ends of the lines of force along the connecting wire  $c$  constitutes what is conventionally known as an electric current, and according to the two-fluid theory negative electricity would be said to be flowing from the earth to  $a b$ . What really happens is that the strains in the dielectric change in the manner indicated by the movements of the lines which we have described. It has been agreed that the current shall be referred to as flowing in the opposite direction to that described above. In other words, *the electric current indicated by a motion of the POSITIVE ends of the lines is in the direction of the motion, whilst that indicated by*

the motion of the negative ends of the lines is in the direction opposite to the direction of the motion. Notice that it is the motion of the ends of the lines which indicates the existence of a current, and that in this case the current is downwards through  $c$  (see page 127).

**The Electric Spark.**—When in the gap between  $\kappa$  and  $a$  (Figs. 60 and 66) the lines become very closely packed they indicate that the electric force in the gap is very great, and it may become so great that the dielectric can no longer stand the strain, but breaks down under it. At the moment when this takes place a spark will be observed in the gap, and a slight sound may be heard. We have veritable lightning and thunder on a minute scale. The dielectric, if a gas like air, immediately mends itself, and no trace is left of the breakdown, but if a solid dielectric be placed in the gap, as, for instance, a sheet of dry paper, evidence of the rupture is left in the shape of a small hole in the paper. This hole has usually a burr on both sides.

**Action of Points.**—We have seen that the density of electrification depends on the curvature of the surface, and is always greatest where the curvature is greatest. We may imagine every surface to consist of superficies, which, according to the amount of curvature they have, may be parts of larger or smaller spheres. A level plain may thus be said to be part of an enormously large sphere, a point part of a sphere infinitely small. The level earth, in comparison with all other movable conductors on its surface, has an infinitely small curvature.

When a conductor terminates in a point, the density must be greatest at that point, no matter how small or how large is the charge of the body itself, for the lines of force coming from the region of space in front of the point tend to crowd on to its small surface as seen in Fig. 56. This may lead to the following consequences:—

- (i.) If there be on the point any parts of the material of the conductor which are not very rigidly attached to it, these parts will be torn off by the electric forces, and the lines of force which terminated on them will be carried away with them and disappear from the field. Thus the conductor will lose some of its charge.
- (ii.) Conducting dust particles floating in the air will be attracted to the point as the cylinder  $ab$  (Fig. 66) is attracted to  $\kappa$ , only being light they will move up to the point and touch it. They receive a charge exactly in the same way as the proof-plane in Fig. 65, but the pull of the lines of force in their tendency to contract is sufficient to drag them off, and so they are removed with their charges.
- (iii.) As a result of Coulomb's law of force (page 64) it can be shown that the electric force very close to a charged surface is equal to  $2\pi\sigma$  where  $\sigma$  is the *density* of the surface charge. Now on a point this surface density is great, as we have seen above, and therefore the electric force is great, which may lead to the partial

rupture of the dielectric, that is, to its breaking down under the strain which constitutes the electrified state. In this case also some of the electrification disappears. The density on a mathematical point would be infinite, and if we could place such a point on a body it would be impossible to charge it.

- (iv.) There is reason to believe that under the influence of a great electric force the particles of the air itself may become electrified and act as carriers like the dust particles in it.

The dissipation of the electric charge, due to one or more of the above causes, sets up a current of air called an electric whirl or wind; and when the electric force is great this current becomes strong enough to blow aside a candle flame, as illustrated in Fig. 67. If an insulator or

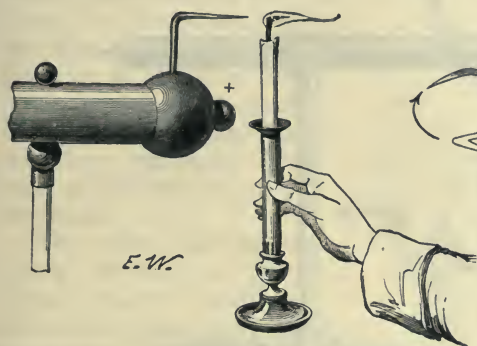

Fig. 67.—Electric Wind from Charged Point.

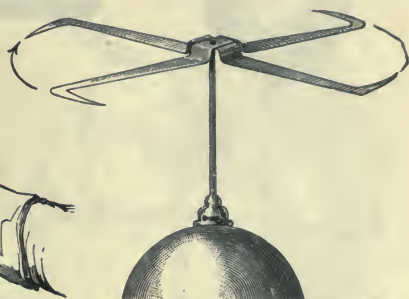

Fig. 68.—Electric Windmill.

solid dielectric be held in front of the point from which the wind is proceeding, it becomes charged with electricity of the same sign as that on the point.

The flow of air from the point forward causes a pressure on the point backwards, for action and reaction are equal and contrary. To show this experimentally, the apparatus represented in Fig. 68 may be used. It consists of metal bands or wires, having the form of an **S**, pointed towards the ends and balanced to move round a vertical axis. The whole apparatus is placed on the conductor of an electric machine, as shown in the figure. As soon as the conductor and apparatus (which, of course, consists of conducting material) have acquired a certain charge the points act in one or more of the ways described above, causing a motion of particles away from the points, and therefore the motion of the wheel in the opposite direction as indicated by the arrows. The efficiency of an ordinary point to effect discharge depends partly on its position, that is, on the curvature of the surface on which it is placed.



A point in a conductor under induction may have the same effect as contact with the earth. Thus, let as before  $a b$  (Fig. 69) be an insulated conductor under the influence of the charged conductor  $\kappa$ , but let a pointed wire be placed in the cylinder at  $b$ . The lines of force (Fig. 60) at  $b$  will tend to concentrate on the point and will disappear by some of the actions described above. The cylinder  $a b$  will therefore be charged negatively, as can be proved by first taking away the pointed wire and then removing  $a b$  from the field of  $\kappa$ , which retains its original charge.

If, however, the pointed wire be placed at  $a$  facing  $\kappa$  the lines at that end will disappear by the action of the point. The result will be that

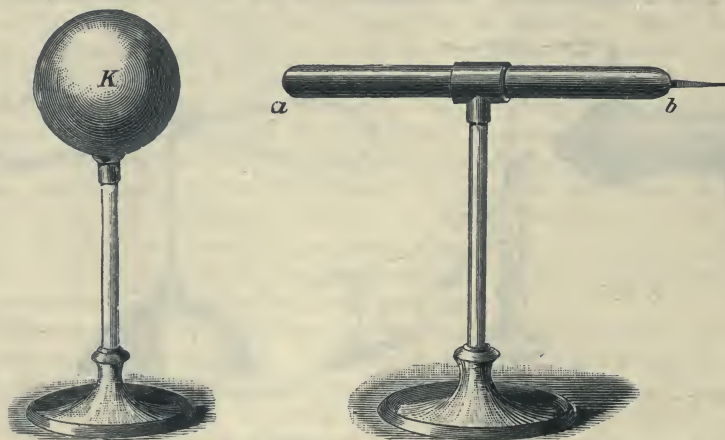

Fig. 69.—Effect of a Point on a Conductor under Induction.

$a b$  will be left with a positive charge, whilst  $\kappa$  will have lost a part of its positive charge equal to the charge on  $a b$ . The same result would be obtained if the point were placed at the other side of the gap on  $\kappa$  so as to face  $a$ ; again the lines in the gap would disappear.

This tendency of points to produce discharge must be taken into account in the construction of apparatus, and sharp edges, prominences, etc., must be avoided.

**Glowing or Burning Bodies.**—Flames on conductors produce the same phenomena as are observed to result from placing points on conductors, etc. The formation of points in burning bodies is far more perfect than the artificial formation and more nearly attains to the mathematical conception; as a result, the best way to discharge the electrification of non-conducting bodies is to draw them several times through a gas flame.

## IV.—ELECTRICAL MACHINES.

The operation of rubbing together and then separating two dissimilar bodies, selected from such a list as is given on page 60, is obviously one which can be accomplished very readily by mechanical means. We have already referred to some of these in the historical introduction and to their gradual improvement in shape from globes to cylinders and from cylinders to plates. We have also mentioned the introduction of the prime conductor and the invention of the point collector in 1746. The mode of action of the latter has now been explained. We take up the development at this stage.

The *Plate Machine* in course of time has gone through many alterations; its essential parts, however, remain the same. Fig. 70 represents the form the Vienna electrician, Winter, gave to it. The principal parts are the glass or ebonite disc *S*, the rubber *R*, the two conductors  $c_1$   $c_2$ , and the glass rods  $G_1$   $G_2$   $G_3$   $G_4$  used as supports. On  $G_1$  rests one end of the wooden axle of the glass plate;  $G_2$  supports the other end;  $G_3$  supports a U-shaped piece of wood, which is so arranged that

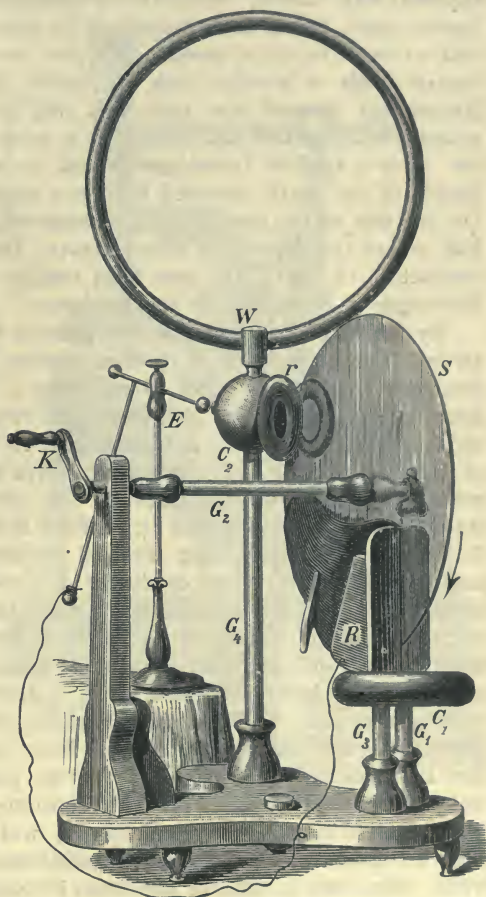

Fig. 70.—Winter's Electric Machine.

between each limb and the glass plate a rubber *R* may be inserted. These rubbers consist of flat pieces of wood covered first with some woollen cloth and over this with leather. The leather has a coating of tin, zinc, or mercury amalgam, and is pressed against the disc by a spring, which lies between the limb of the wooden U-shaped frame and the rubber.

Both rubbers are connected with the negative conductor  $c_1$ . The positive or prime conductor, a hollow brass ball  $c_2$ , rests on the glass rod  $g_1$ . Wooden rings  $r$  run from the brass ball parallel to the glass plate on each side of it; the portion of the ring facing the glass plate is covered with tinfoil, which is in connection with the conductor and carries metal points so arranged as to stand at right angles to the plate and as near to it as possible without touching it. Winter, as a rule, further adds a wooden ring  $w$ , which has a spiral of metal in it. Experiment showed him that this ring increases the capacity\* of the prime conductor and acts exactly as a sphere of the same radius would do. It is a kind of "condenser,"\* and on adding the ring, therefore, the length of the spark obtained from the machine is considerably increased. On the side of the conductor  $c_2$  opposite to the two rings is a small brass ball, where the density is always greater than at any other place on the conductor. A spark will pass most readily from this little ball over to a discharger  $e$ , brought near the conductor.

By means of the handle  $k$  the plate is turned in the direction of the arrow. The glass plate is rubbed against the amalgamated rubber, and becomes positively charged. Glass being a bad conductor, the electricity does not spread all over the plate, but remains where it is produced, as shown on pages 78, 79. If we continue to turn the machine, these parts of the plate carrying with them the positive electricity will come under the metal points of the wooden rings  $r$ . The action which now takes place is exactly that described on page 84, where it is shown that the ball  $k$  would be discharged by a point being directed towards it from the conductor  $a b$ , and that on the insulated conductor  $a b$  would be found then a charge equal to that lost by  $k$ . In the language of the fluid theory, the positive electricity on the surface of the plate induces positive electricity at the farthest end of the conductor and negative electricity at the near surfaces. The latter will now cause a discharge at the metal points of  $r$  on to the plate  $s$ . This will neutralise the positive electricity of the glass plate, and the glass plate will leave the metal rings unelectrified. But new positive electricity can now be produced in the same manner, and the process repeated; if we continue to rotate the plate  $s$ , the positive electricity in the conductor  $c_2$  will accumulate. We also know that we produce positive and negative electricity in equal quantities; what, then, has become of the latter? Negative electricity is produced on the rubbers, which, as we have mentioned, are insulated and connected with the negative conductor  $c_1$ . Hence the negative electricity produced passes directly to the negative conductor  $c_1$  and accumulates there. If now we continue to rotate the disc, the collected negative electricity with its associated lines of force will soon have a sufficient density to break down the dielectric and to discharge to earth or even to the prime

\* The exact meaning of these terms will be explained later.



conductor. In the latter case the machine would be discharged. To prevent this, the negative electricity is passed to the earth by attaching a chain to the negative conductor. By continued rotation the charge of the positive conductor will now increase.

We cannot, however, continue this process indefinitely, as the charge on the positive conductor will ultimately become so great that positive electrification will appear at the metal points on the upper part of the rings *r* and opposite the diselectrified glass plate which has passed the points on the lower part of *r*. The result will be that the points, acting in the usual way, will discharge the electrification which gathers on them towards the flat glass plate, which will thus become re-electrified, and on balance no further electricity will accumulate on *c*. When, however, the positive electricity is also conducted away, the machine will be a continuous source of electricity as long as the plate rotates. If only sparks are required, the chain suspended from the negative conductor is brought into contact with the discharger, as shown in the figure. If we require — instead of + electricity, the chain is removed from the negative conductor and placed on the + conductor. We can then collect the negative electricity from the lower conductor *c*.

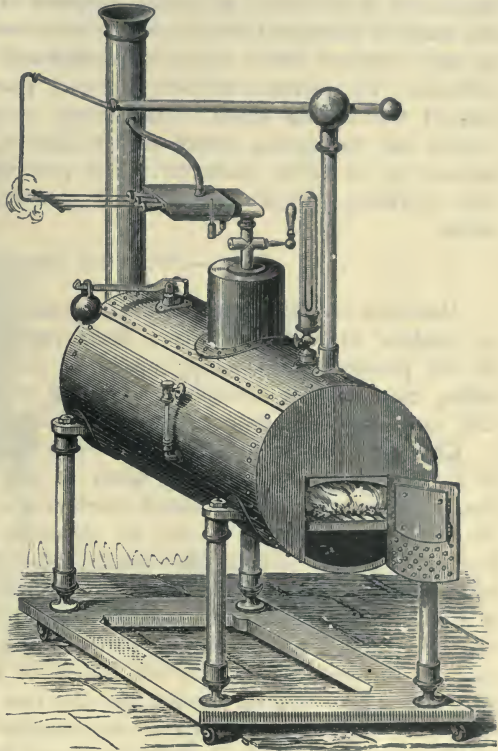

Fig. 71.—Steam Electric Machine.

**Hydro-Electric Machine.**—An engine-driver named Seghill observed in 1840 that the steam escaping from a safety-valve may become electrified. Armstrong and Pattinson insulated the boiler, and placed metal points opposite the escaping steam. The metal points were in connection with a conductor. These experiments showed that the steam became positively electrified, and the boiler negatively.

Armstrong constructed the machine represented in Fig. 71. The boiler rests on four strong glass pillars, and is furnished with a safety-valve, a manometer, and a steam dome, from which the steam passes to the escape pipes. In its passage the steam has to go through a kind of iron box, in which it is partly condensed, because it is of importance that the steam should carry as much moisture as possible. The escape pipes are made of different forms by different makers; the chief object, however, in all, whatever their shape, is to increase the friction of the water globules. To increase friction, Faraday placed a cone with the point against the issuing steam. Armstrong placed a disc in front of the steam, and the issuing steam strikes against a series of metal points in connection with the conductor. The positive electricity then collects on the conductor, whilst the negative electricity is distributed over the boiler.

#### V.—INFLUENCE MACHINES.

Machines in which surfaces continuously rubbed together are employed to produce electrification have been supplanted in more recent times for all practical purposes by machines in which a small initial charge acting inductively is multiplied, according to a kind of compound interest law, until it attains proportions far exceeding its initial value.

**Charging by Induction.**—How this may be done may be understood in a general way by referring again to Fig. 66, where we have shown that by connecting the insulated conductor  $a b$  to the earth all the lines between it and the earth will be removed, and only the lines passing from  $\kappa$  to it will remain. But under these conditions there is a *negative charge* on  $a b$ , and if the wire  $c$  be removed the two conductors  $\kappa$  and  $a b$  are much in the same relative position as regards electrification as the two rubbed and separated plates in Fig. 57; the chief difference is that *all* the lines from  $\kappa$  do not end on  $a b$ . This being the case these two bodies may now be treated like the two plates, and further separated until their two charges cease to be directly connected by lines of force, all the lines from  $\kappa$  now passing to earth and the lines ending on  $a b$  reaching it from the earth.

At this stage it is evident that  $a b$  can be used to charge positively a third conductor  $c d$  by induction, after which  $a b$  can be caused to give up its negative charge to a fourth conductor  $L$ , and  $c d$  can give up its positive charge to  $\kappa$ . The whole cycle of operations can then be gone through again and again. At the end of each cycle the charges of  $\kappa$  and  $L$  will be increased, whilst  $a b$  and  $c d$  will be completely discharged. It is important, therefore, to understand the conditions under which a charged body may be made to give up its charge completely to another body similarly charged. Faraday first showed how this could be done in his celebrated ice-pail experiment.

**Faraday's Ice-pail Experiment.**—In this experiment an ice-pail  $P$  (Fig. 72), connected with the gold leaves of an electroscope  $C$ , is placed on an insulating stand  $S$ . A charged conductor  $K$ , carried by a silk thread, is lowered into the pail, and eventually touches it at the bottom. Whilst it is being lowered the leaves of the electroscope diverge farther and farther, until  $K$  is well within the pail, after which they diverge no more, even when  $K$  touches the pail or is afterwards withdrawn by the insulating thread. After withdrawal  $K$  is found to be *completely discharged*.

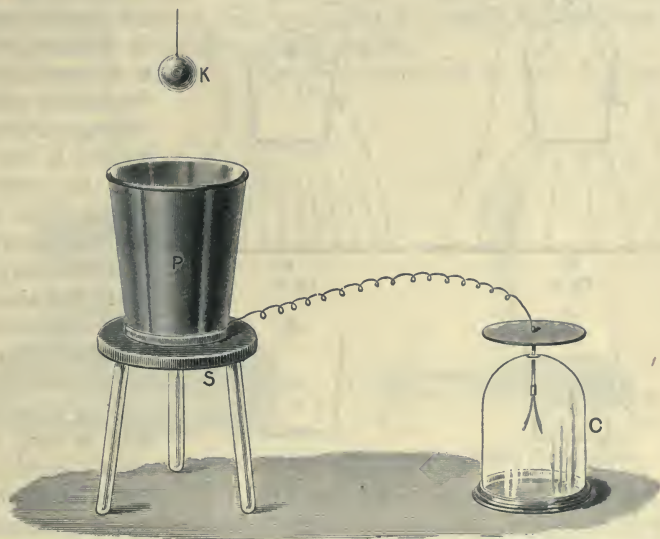

Fig. 72.—Faraday's Ice-pail Experiment.

These results are easily explained by tracing the effects of the movements of  $K$  on the lines of force in the dielectric. Four stages,  $a$ ,  $b$ ,  $c$ , and  $d$ , are shown diagrammatically in Figs. 73 to 76, in which for simplicity the electroscope, the insulating stand, and the silk suspending thread have been omitted. Only the three principal conductors  $K$ ,  $P$ , and the earth  $E$  are shown. Previous to  $a$  we must picture  $K$  with its twelve lines of force at such a distance from  $P$  that the latter is unaffected and no lines pass from it to  $E$ . In  $a$  the ball  $K$  has approached sufficiently close to  $P$  to act inductively on it; six lines are shown as falling on  $P$ , and the other six as passing to  $E$  by different paths. Corresponding to the six lines falling on  $P$  from  $K$ , six others pass to  $E$  from the lower surfaces. In  $b$  where  $K$  is just entering the pail two lines only pass from  $K$  to  $E$  through the dielectric; the remaining ten fall on  $P$ ,



and ten others starting from the distant parts of  $P$  pass to  $E$ . In  $c$ ,  $K$  is so far within  $P$  that none of its lines can reach  $E$  through the dielectric; they all fall on  $P$  and from the outside of  $P$  an equal number start and pass through the dielectric to  $E$ . It is evident that in this position  $K$  can be moved about within  $P$ , without affecting the outside distribution in the slightest, and that even when  $K$  touches  $P$  as shown in  $d$ , and when,

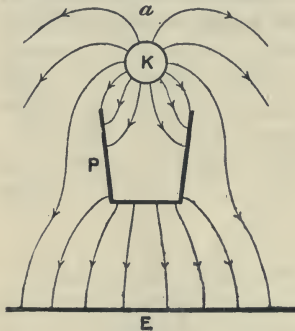

Fig. 73.

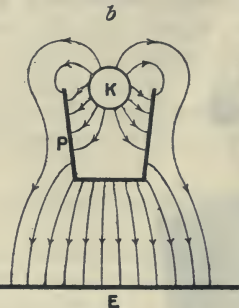

Fig. 74.

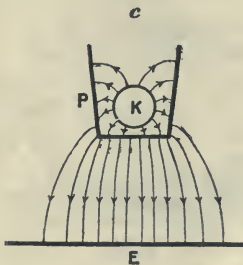

Fig. 75.

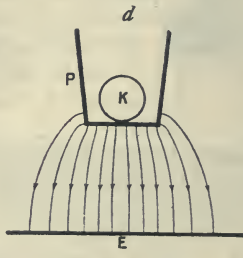

Fig. 76.

Lines of Force in Different Stages of Ice-pail Experiment.

therefore, all lines between them disappear, the lines in the dielectric outside remain just as they are in  $c$ . But  $K$  is now completely discharged since lines no longer emanate from it, and it can, therefore, be removed by means of the silk cord without disturbing the electrification of  $P$ .

If the electroscope were connected to  $P$  it would take a definite proportion of the lines passing from  $P$  to  $E$ , and as long as these were increasing the deflection of the leaves would increase; as soon, however, as  $K$  is well inside  $P$  and no further lines can be induced outside, the deflection of the leaves will become stationary, and remain so even when

$K$  touches  $P$  and is then removed.

If  $K$  be again charged and introduced into  $P$  it will be again discharged, for the fact that  $P$  is already charged will have no effect on the final result, provided when  $K$  touches  $P$  it is well *under cover*. This latter is the essential condition, and is not quite fulfilled by the ice-pail, which is too open at the top. The result of this will be that when the ice-pail becomes highly charged some of the lines from  $K$ , even when it is near the bottom, may find their way out through the wide opening, and if this happens  $K$  will not be completely discharged. It is easy, however, to arrange apparatus in which this essential condition is effectively satisfied.

**The Electrophorus.**—The first piece of apparatus with which electrification by induction was used for the production of fairly large charges was the electrophorus, devised by Volta in 1775, though Wilke had, in 1762, described an arrangement of glass plates in which the principle of induction was employed for the production of successive charges.

One form of electrophorus is represented in Fig. 77, in which *A* is a cake of resin, *B* and *C* metal discs connected by means of silk threads, *i* an insulating handle. The more common form, however, which is shown in Fig. 78, dispenses with the lower disc *B*; here *E* is a metal form on which the cake of resin *H* rests, *D* a metal disc which is sometimes called the carrier, and *G* an insulating glass handle.

By rubbing the cake it is negatively electrified on its top surface. If

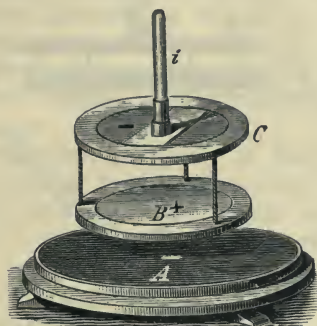

Fig. 77.—Early Electrophorus.

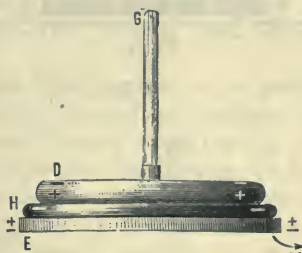

Fig. 78.—Modern Electrophorus.

now the disc be placed upon the electrified cake and touched for a moment with the finger and then lifted, it is found to be positively electrified.

This result will be easily understood by applying the principles already explained to the four distinct stages of the operation, as illustrated in Figs. 79 to 82. In all the figures the metal plate *E* is assumed to be connected to the earth. In Fig. 79 we have the cake of resin *H* with its upper surface electrified, and therefore with lines of force passing through the resin (which is a dielectric) and through the air from *E* to this upper surface; only two lines at each end are shown as passing through the air, for the field in the air will be much feebler than the field in the resin, because of the longer distances. In Fig. 80 the disc *D* is supposed to be resting on the resin *H*, but in order that the lines of force may be drawn a much wider gap than the actual one is shown in the diagram. The presence of the insulated conducting disc on the side farthest from the earth will have very little effect on the distribution shown in Fig. 79; it will only affect the lines passing through the air, which will be cut in two, and those ending on the

disc will run to the edge, leaving the air above the disc without any perceptible field, the portions starting from the disc retaining their original positions in the gap.

In Fig. 81 the disc is being touched with the finger, and therefore is now a little nearer earth than the plate E. Consequently the greater number of lines will now be in the very thin layer of air between D and H, and only a few will remain in the resin passing from E to the

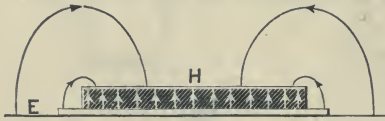

Fig. 79.

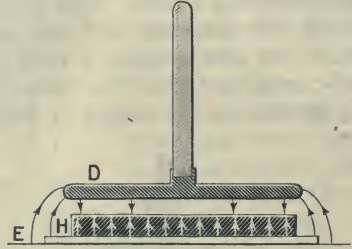

Fig. 80.

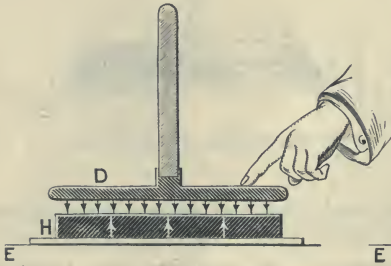

Fig. 81.

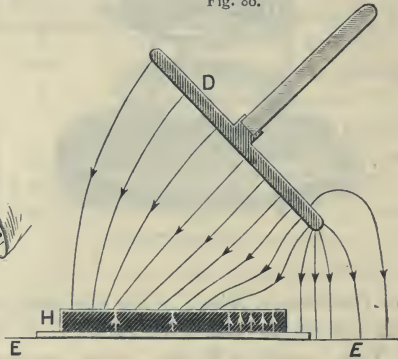

Fig. 82.

Lines of Force in Different Stages of Charging Electrophorus Plate.

upper surface of H. A figure intermediate between 80 and 81 with the finger approaching D would show some lines starting from D and falling on the finger, an equal number of lines being withdrawn from the substance of the resin and crossing the air gap from D to H.

In Fig. 82 the disc D is shown as it is being carried away from H by means of the insulating handle. As the disc is tilted the lines starting from it will crowd down to the lower corner near E, and will successively break into two, one part passing from D to E direct and the other from E through the resin to its upper surface. The ends of the lines on the resin must be regarded, in drawing these figures, as approximately fixed, thus accounting for the peculiar dragging action shown in the last figure.



As the disc is moved farther away more lines pass from it direct to the earth, until finally none of the lines starting from  $D$  pass through the air to  $H$ . The disc is now charged and independent of  $H$ , which has returned to the state shown in Fig. 79. If the charge on the disc be now used and the disc brought back again uncharged, the whole cycle of operations can be gone through once more.

To avoid the necessity of touching with the finger each time the disc  $D$  is placed on  $H$ , a thin metal wire connected to  $E$  may be passed up through a hole in the resin, the top end of the wire being flush with the upper surface of  $H$ . When  $D$  is placed on  $H$  it either touches this wire or sparks to it, and the wire acts the part of the finger in connecting the metal of the disc  $D$  to  $E$ . As soon as the disc begins to be lifted electrical connection with the wire is broken, and things proceed generally as before, the result as regards the final charge on  $D$  being practically the same. It will be a useful exercise for the reader to draw diagrams for the different stages, especially for those intermediate between Figs. 79 and 82, when the wire is used instead of the finger.

**Influence Machines, or Continuous Electrophori.**—In producing electricity by friction, glass rods, etc., were replaced by machines which would perform the operation more continuously; and in a similar manner the principle of the electrophorus has been extended to the construction of what are called continuous electrophori, or electrostatic influence machines. They are designed to carry out the method sketched roughly on page 91, and they usually employ the device of bringing a conductor, which has been charged by induction, *under cover* to discharge it completely. Instruments applying these principles have been constructed by Varley, Thomson, Carré, Holtz, Voss, Wimshurst, and others. Carré's machine is a combination of a plate machine with rubbers, etc., and an influence machine.\*

The form shown in Fig. 83 was devised by Holtz, of Berlin. The wooden frame  $AB$  supports the well-varnished glass plate  $EF$  by grooved rods  $d d d$  supported on glass pillars. This fixed plate  $EF$  has three openings; the one in the middle allows the axis of the rotating second plate  $CD$  to pass, the second opening is at  $n$ , and the third at  $n'$ . These latter form sector-shaped windows in the plate. Just above the opening  $n$  and under  $n'$  are glued on the farther side of the plate  $EF$  paper inductors  $m m'$ , from the edges of which tongues of card project and pass through the windows  $n n'$ , so as to touch the revolving plate  $CD$ . The plates, inductors, and tongues are carefully varnished with shellac varnish. The plate  $CD$  can be rapidly rotated in a clockwise direction as seen from the front. Opposite to  $m$  and  $m'$  two series of fine metal points are so arranged that  $CD$  moves between them and the fixed

\* This machine is fully described on page 59 of the 1893 edition of this work.

plate  $E F$ . The metal points are held by carefully insulated brass bars  $p g o$  and  $q g' o'$ , which terminate in the balls  $o$  and  $o'$  through which metal rods run, having the insulated handles  $h h'$ , and the small spherical terminals  $i i'$ , termed the poles of the machine.

To start the action of the machine the balls  $i i'$  must be brought into contact, and one of the paper inductors must be well charged

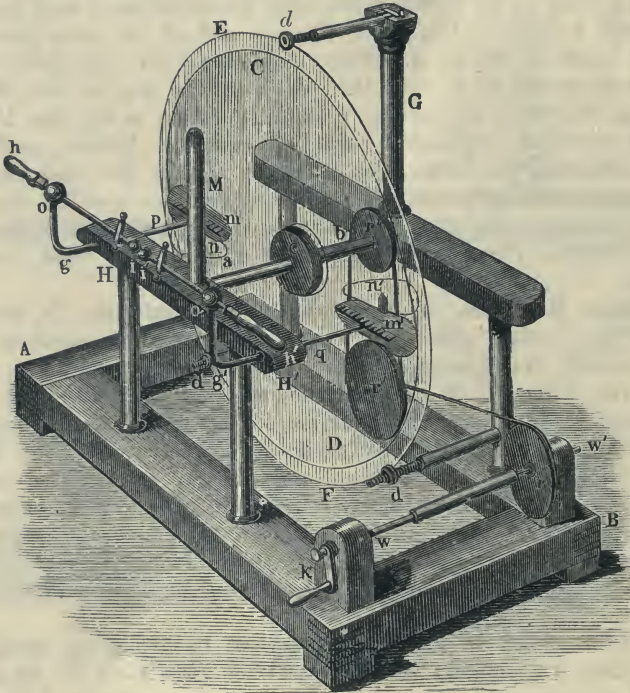

Fig. 83.—Holtz Machine.

either from a rubbed glass or ebonite rod or the plate of an electrophorus, or from a Leyden jar. If everything is in good order brushes will soon appear at the metal points as the rotation proceeds, and if the balls  $i i'$  be then drawn apart a torrent of vivid sparks will pass between them.

To explain this action we must refer to the diagrammatic Fig. 84, in which the portion  $x$  on the right represents a vertical cross section through the window  $n'$ , the inductor  $m'$ , the *descending* plate  $c d$ , and the fixed plate  $E F$ , all on the right-hand side of the machine in Fig. 83; whilst the portion  $y$  on the left represents a similar section through the window  $n$ , the inductor  $m$ , the *ascending* plate  $d c$ , and the fixed

plate  $E F$ , all as seen from the left-hand side of the machine in Fig. 83. The paper inductors  $m m'$  and the tongues  $t t'$  passing through the windows  $n n'$  are to be regarded as conductors. The rods  $P P'$  carrying the metal points are represented as joined by a conductor. The diagram is intended to show the condition of things when the plate has made half of a complete turn from the moment that  $m'$  received a strong  $+$  charge. As the drawing of lines of force would confuse the figure too much, we shall refer only to the charges which are at the ends of those lines.

The first action of the  $+$  charge on  $m'$  is to induce a  $-$  charge on  $P'$  and a  $+$  charge on  $P$ . These charges are both discharged by the points against the front surface of the revolving plate. The  $+$  charge at  $y$  also induces a  $-$  charge in the inductor  $m$ , and a discharge of  $+$  electricity from the pointed tongue  $t$  against the back of the plate, which, being carried forward opposite  $m$ , increases the inductive action of the  $+$  charge on the front of the plate, and the  $-$  charge on the back of the plate is thereby still further increased.

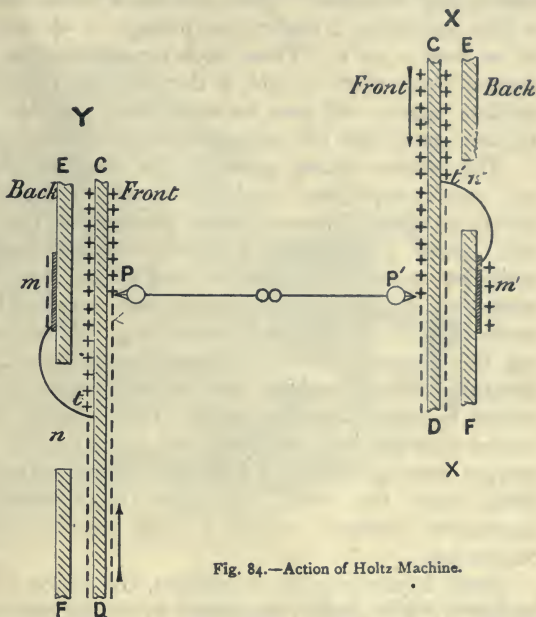

Fig. 84.—Action of Holtz Machine.

The plate, therefore, passes forward with  $+$  charges on both front and back, but the latter charge is concentrated on a narrower zone. Let us follow these charges round to the  $x$  side. The  $+$  charge on the back comes first to the tongue  $t'$ , and is transferred to the inductor  $m'$ , whose charge is thereby increased. The front  $+$  charge causes  $t'$  to discharge  $-$  electricity against the back of the glass, thereby further increasing the  $+$  charge on  $m'$ . This  $-$  electricity, as soon as it passes  $P'$ , acts inductively on  $m'$ , still further increasing the  $-$  flow from  $t'$  and the  $+$  charge on  $m'$ . Thus, soon both sides of the glass are leaving  $P'$  with  $-$  charges. The front  $+$  charge opposite  $t'$  passes on to the points  $P'$ , whence it passes over to  $P$ , additional  $-$  electricity being discharged against the front side by the increasing inductive action of  $m'$ .

Going back now to the  $-$  charge discharged at the starting of the



action against the front of the glass at  $P'$ , this  $-$  charge passes round to the  $\gamma$  side, and there, before coming opposite to  $P$ , causes the tongue  $t$  to discharge  $+$  electricity against the back of the plate, thus still further increasing the  $-$  charge on  $m$ , and the  $+$  charge being carried over the top by the back to the  $x$  side. The actions described as proceeding at the  $x$  side due to the arriving  $+$  charges on the glass are repeated at the  $\gamma$  side with the  $-$  charges, the signs being reversed.

The action is therefore continuous, for the charges on  $m'$  and  $m$  are continually increased. The continuous inductions taking place at  $P'$  and  $P$  also necessitate a continuous passage of  $+$  electricity from  $P'$  to  $P$  and of  $-$  from  $P$  to  $P'$ . These both constitute what is known as an *electric current* from  $P'$  to  $P$ , and if the balls in the centre are now separated brilliant sparks will pass between them, for the strains in the gap will be very great and will be continuously renewed as the dielectric gives way.

The actions taking place in the medium during the above changes are very complicated, and it would be impossible to represent them clearly by lines of force without multiplying the figures to an unmanageable extent. The fact is that, although such machines are usually described under the section of the subject dealing with electrostatics (or electricity at rest), chiefly because they were used at first to communicate static charges to insulated conductors, yet whilst the machine is working the phenomena are not static but kinematic, and actual currents of electricity of high voltage but of small quantity may be steadily maintained for an indefinite period. With regard to the  $+$  charges being carried over on both sides of the rotating glass at the top, and the  $-$  charges passing over at the bottom, many of the lines of force, of which these form the ends, will have their other ends moving on the conductors between  $P'$  and  $P$ , and constituting the current on these conductors.

Small Leyden jars or condensers, the action of which will be presently explained, are usually employed in connection with these machines to strengthen the spark, and are often mounted permanently as part of the apparatus, large tubes fitted up as jars taking the place of the glass pillars employed for insulation.

The Holtz machine, as above described, was somewhat difficult to start working, especially in damp weather. It was improved by Holtz himself and also by Toepler and Voss. In these later machines the principles referred to in our descriptions of the electrophorus and Faraday's ice-pail experiment are used more effectively than in the early Holtz machines.

**The Voss Influence Machine.**—In this machine there is a fixed plate of thin glass  $E$  (Fig. 85), say  $12\frac{1}{2}$  inches in diameter, with a central opening. This plate has fixed upon its farther side two pairs of tinfoil discs, each pair being connected by a strip of foil. These discs  $F F$  are covered by

paper shields *G G*, which are slightly conductive. The moving plate *H* is of  $10\frac{1}{4}$  inches diameter, and at six equi-distant points of a circle of  $7\frac{1}{2}$  inches in diameter are fixed inch discs of tinfoil, upon the middle of each of which there is cemented a metal button, rising  $\frac{1}{3}$  inch from the surface. These discs *i i* correspond in size with those of the fixed plate; they are the same distance apart and placed so as to come successively opposite the fixed discs as the plate *H* revolves. The collecting system consists of a fixed horizontal ebonite rod *L*, at each end of which is a brass T-piece, carrying a collecting comb on one arm and on the other arm a

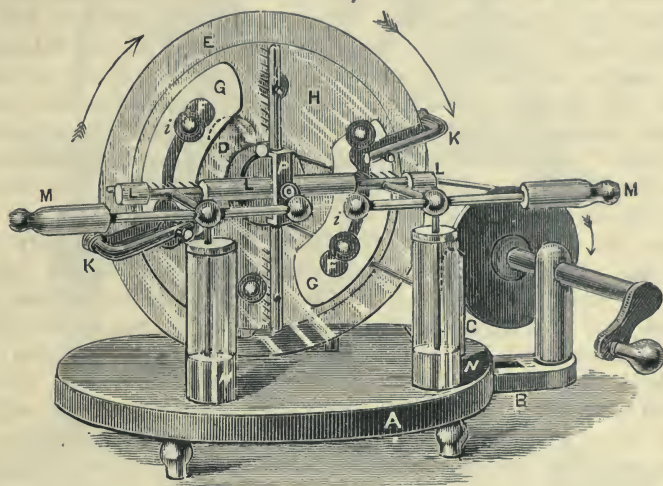

Fig. 85.—The Voss Influence Machine.

ball which carries the discharging rod *M* and is supported by the insulated conductor of a small Leyden jar *N*.

A second pair of combs is attached to a brass frame *P*, also placed on the axis, and secured there by a knob of ebonite screwed upon the end. These combs are shown vertical, but for most effective action should be sloped backwards  $30^\circ$  in a counter-clockwise direction. They have fine wire brushes in their middles, which touch the buttons and short circuit a pair of discs just before they leave the cover of the paper shields. *K K* are bent arms of metal, attached by clamps to the fixed plate, and connected by strips of foil to the nearest foil disc. These arms carry fine metal brushes, which are adjusted to touch the buttons on the moving plate when they face the foils on the fixed plate.

The action of the machine is usually started by bringing the two discharging knobs into contact and charging one of the fixed conductors

F F. On rotating the plate H charges rapidly accumulate, and on separating the knobs a torrent of sparks can be obtained.

The explanation of the action is fairly simple. Assume the left-hand inductor to be positively charged and that one of the moving discs or carriers  $i$  is between the left-hand comb of P and the  $+$  inductor. The carrier will become negatively charged and a certain amount of  $+$  electrification will be collected by the comb. The carrier passes on and (neglecting for a moment the action of the diagonal conductor P) passes over to the right-hand side, where it touches the brush attached to the bent arm  $\kappa$ , which it will be remembered is electrically in contact with the right-hand inductor. When the carrier touches this brush it is electrically covered very fairly by the metal of the inductor and of the arm  $\kappa$ , and therefore completely gives up its charge as the ball does in the ice-pail experiment (page 89). The right-hand inductor, therefore, receives a  $-$  charge, and the carrier passes on uncharged to the brush of the combs connected to the right-hand discharging ball. Whilst touching this brush the  $-$  charge of the inductor acts inductively on the metallic system of which the disc now forms one end, and in consequence the disc becomes positively charged whilst  $-$  electricity appears on the ball. The charged disc then passes on insulated to the right-hand comb of P, and the actions just described are repeated in the lower half of its travel with reversed electrifications. Thus the charges on the inductors rapidly increase and electric currents pass from left to right through the joined discharging balls. If, after a little time, the latter are separated the potential difference of the two balls rapidly becomes sufficiently great to cause a brilliant discharge spark to pass between them.

The action of the diagonal conductor P is important. It will be observed that it simultaneously touches two carriers which are under opposite inductive actions. The result is that, for a moment, the two carriers and P form a single insulated conductor with two oppositely charged inducing conductors opposite its ends. The inductive action is therefore concentrated on the carriers, which pass on bearing charges much greater than if P were absent.

This machine is exceedingly powerful in favourable weather, but has an important defect, in a tendency to *self-reversal*, which is apt to occur at a stoppage, and which is probably due to the oscillatory character of the Leyden jar discharge (see Chapter XVII.). This defect is not found in the next machine described, but can be produced in a Voss machine when desired by holding a metal point to the  $+$  brush  $\kappa$ . The two derived inductive circuits in this machine are beautifully manifested when it is worked in the dark. A luminous stream is seen pouring towards the positive collecting comb on whichever side of the machine it is placed.

**Wimshurst's Influence Machine.**—This machine, invented by Mr. James Wimshurst, one of the consulting engineers of the Board of Trade,



is one of the best induction machines yet constructed. In its simplest form it consists of two circular discs (Fig. 86) of thin glass, which are attached to loose bosses revolving on a fixed horizontal spindle, so as to be rotated in opposite directions at a distance apart of not more than

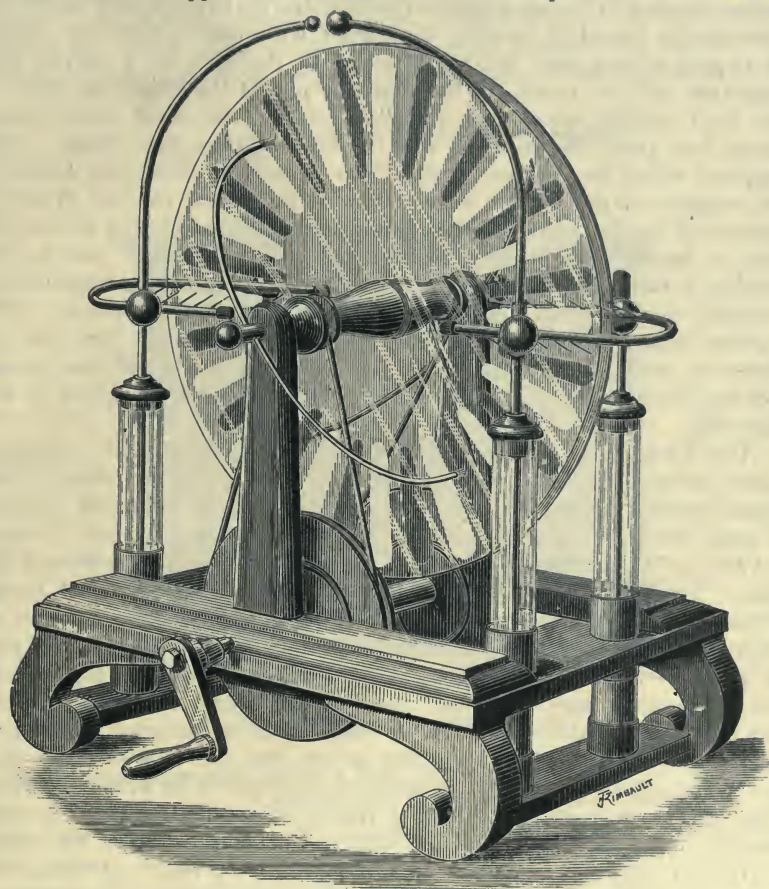

Fig. 86.—Wimshurst's Machine.

about one-eighth of an inch. Each disc is driven by a cord or belt from a large pulley—of which there are two attached to a spindle below the machine—which is rotated by a winch handle, the difference in the direction of rotation of the discs being obtained by the crossing of one of the belts. Both discs are well varnished, and attached by cement to the outer surface of each are twelve or more radial sector-shaped plates of thin brass

or tinfoil, disposed around the discs at equal angular distances apart. These sectors take the place of the "inductors" of Holtz's machine, and also act as carriers, those acting for the time as carriers on the one disc acting at the same time as inductors with respect to the other. The two sectors situated on the same diameter of each disc are twice in each revolution momentarily placed in metallic connection with one another by means of a pair of fine wire brushes attached to the ends of a curved rod, supported at the middle of its length by one of the projecting ends of the fixed spindle upon which the discs rotate; the metal sector-shaped plates just graze the tips of the brushes as they pass them. This happens when the carriers touched are under the inductive action of the charged carriers on the other disc, with the results referred to in the description of the action of the Voss machine. The position of the two pairs of brushes with respect to the fixed collecting combs, and to one another, is variable, and there is, as in the case of the collecting commutator-brushes of dynamo-electric machines, a position of maximum efficiency. This position appears to be generally when the brushes touch the disc on diameters situated about  $45^\circ$  from the collecting combs and the curved rods on the two sides are at right angles to one another, as shown in the engraving.

The fixed conductors consist of two forks furnished with collecting points directed towards one another and towards the two discs, which rotate between them; the two forks are supported on insulating supports of some kind, which often (for reasons already indicated) consist of small Leyden jars or condensers; the forks are on the horizontal diameters of the discs. To these collecting forks and combs are attached terminal knobs, whose distance apart can be varied by projecting ebonite handles, or otherwise. The presence of these collecting combs appears to play no part in the action of the apparatus, except to convey the electric charges to what may be termed the external circuit; for the inductive action of the machine is quite as rapid and as powerful when both collectors are removed and nothing is left but the two rotating discs and their respective contact or neutralising brushes. The whole apparatus then bristles with electricity, and if viewed in the dark presents a most beautiful appearance, being literally bathed with luminous brush discharges.

With a machine composed of two glass plates, only  $14\frac{1}{2}$  inches in diameter, there is produced, under ordinary atmospheric conditions, a powerful spark discharge between the knobs when they are separated by a distance of  $4\frac{1}{2}$  inches, a pint-size Leyden jar being in connection with each knob; and these  $4\frac{1}{2}$ -inch discharges take place in regular succession at every two and a half turns of the handle. It is usual to construct the machine as shown in the illustration, with small Leyden jars or condensers attached to the conductors, by which the spark is materially increased. A machine has been constructed for the Science and Art

Department, South Kensington, with plates 7 feet in diameter, which it is believed would give sparks 30 inches long; but no Leyden jars have been found to stand its charge, all being pierced by the enormous electric strains.

Mr. Wimshurst has also constructed machines with many pairs of plates. One of these, having six pairs, or twelve plates in all, is shown in Fig. 87. By a series of bands alternately straight and crossed the opposing plates of each pair are driven in opposite directions, but the back

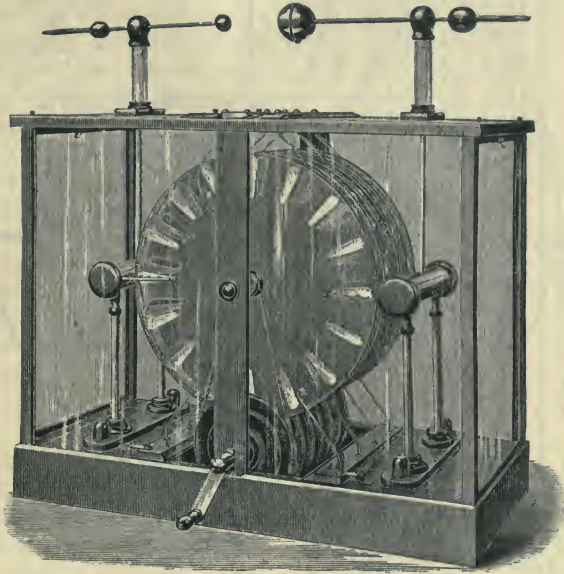

Fig. 87.—Twelve-plate Wimshurst Machine.

plate of the front pair and the front plate of the second pair are on the same hub, and revolve together, and so on throughout; thus seven bands drive the twelve plates. The diagonal conductors of the smaller machines are replaced by seven pairs of conductors fixed to the frame, and making contact at the proper angular positions. Electrically they act as seven diagonal conductors alternately sloping in opposite directions, and the ones between the plates act for the plates on both sides of them. The collecting combs are placed as previously described, and are connected to the two discharging terminals on the top of the glass case in which the plates are enclosed. If Leyden jars are used they are attached to these terminals.

With this machine splendid discharges are obtained. The potential difference reached is not greater than that of a two-plate machine with



plates of the same diameter and pattern, but the quantity of electricity discharged in each spark is probably proportional to the number of plates. Thus the brilliancy of the discharge is increased. Later on we give a photograph of its sparks.

Lord Blythwood had a large eighty-plate machine built on the

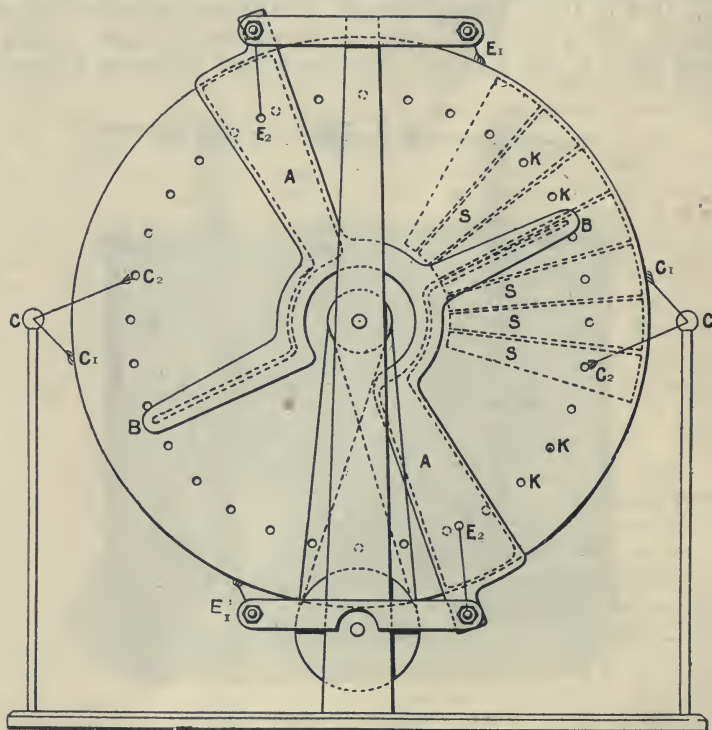

Fig. 88.—Pidgeon's Influence Machine (front).

same plan, and driven by mechanical power. When at work it is a veritable miniature thunder factory.

It is interesting to note that a Wimshurst machine can be run as a *motor*. Let the two revolving discs be mounted with their diagonal brushes so as to be free to run independently. If the diagonal conductors be now connected to the terminals of another machine which is working fully excited, the two discs will revolve under the influence of the electrostatic forces.

**Pidgeon's Influence Machine.**—In 1898 Mr. W. R. Pidgeon, who had worked for some years at the subject, constructed an influence machine,

which he has since still further improved. The principal parts of his most recent machine are shown diagrammatically in Figs. 88 and 89. As will be seen from the side view (Fig. 89), there are nine revolving plates consisting of three groups of three plates each. The central plates 2, 5, and 8 are driven by the central axle in one direction, whilst the outer plates 1, 3, 4, 6, 7, 9 are carried on suitable sleeves and driven by bands in the opposite direction. The chief point of interest is that the conducting sectors *s s s* (Fig. 88) are very close together, and are completely buried in the insulating material of the plate, which is formed of three sheets of "volenite," a substance resembling, but, for this purpose, said to be superior to ebonite. The metallic sectors *s* are placed between the layers of volenite, and on the outer plates carry metallic knobs *k k*, which project through the outer layer of the dielectric. On the central plates 2, 5, and 8 the necessary metallic projections appear on the outer rims instead of the faces of the plates. There are also four pairs of fixed inductors *A*. Each pair is mounted on a sheet of volenite having four radial arms, as shown in Fig. 88, where the shape of the metal inductors is indicated by dotted lines. These inductors collect at *B* small charges from the revolving sectors before the latter reach the collectors *c*. The central plates as seen in Fig. 88 revolve in a counter-clockwise, and the outer

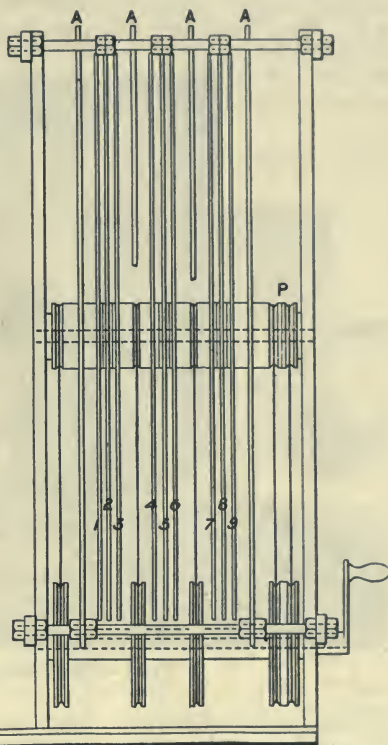

Fig. 89.—Pidgeon's Influence Machine (side).

ones in a clockwise direction;  $C_1, C_2$  are the collectors for the central and  $C_3, C_4$  the collectors for the outer plates, whilst  $E_1, E_2$  and  $E_3, E_4$  are the respective earthing brushes for these plates. Each sector is earthed when it is in the position for maximum induction. For the central plates this is when it is between two similarly charged sectors on the outer plates, whilst for the outer plates it is when it is between a fixed inductor and a sector of the central plate both charged similarly. The air gaps are small, and an appreciable part of the induction is through solid dielectric of high specific inductive

capacity (*see* page 115). The action is therefore rapid and vigorous, and the output obtained is about four times as great as a machine of the same dimensions of the older form.

The Wimshurst and Pidgeon machines are *self-exciting*, and it is believed that the initial action may be due to friction in the layer of air contained between the plates. It is possible, however, that under certain conditions feeble residual charges, sufficient to start the action, may persist for a considerable time. The machines, when properly constructed, are nearly independent

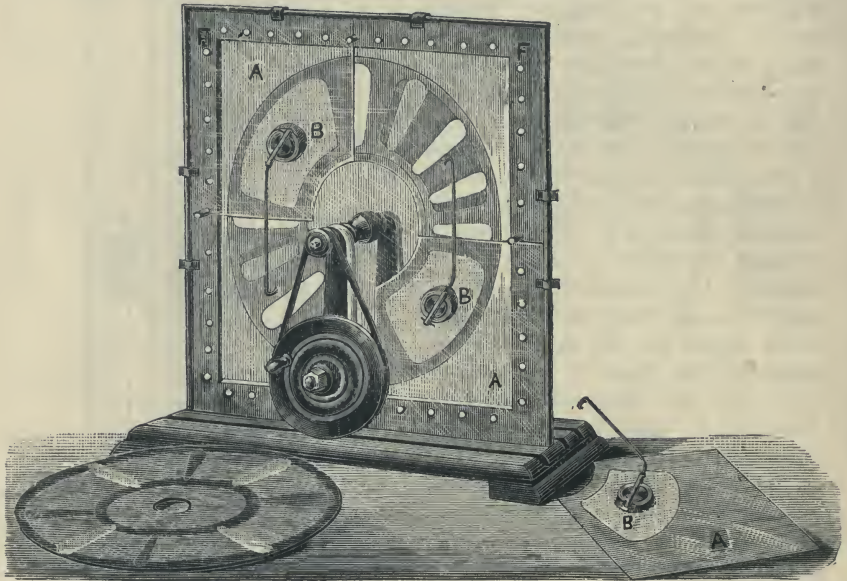

Fig. 90.—Wimshurst Machine with Fixed Inductors.

of atmospheric conditions, and not liable to reverse polarity, as are the Voss machines. These advantages, added to the extreme simplicity of construction, have rapidly given them the preference for all purposes where statical electricity of high voltage is required. The property of self-excitation is found to depend somewhat on the number of sectors. With a high number the machine excites itself very freely, but the sparks are more feeble; with fewer sectors it is less easy to excite, but the sparks are much more powerful when obtained.

In many of the machines described glass is used as the solid dielectric of the working part of the machine. It has, however, the disadvantage of fragility, and cannot be driven at a high angular velocity, especially with large plates. This limits the output, which for a given machine may



be taken as sensibly proportional to the angular velocity. These and other considerations have led Mr. Pidgeon and other constructors to discard glass in favour of ebonite or other material, which can be safely driven at double the velocity. A modification adopted in many ebonite machines is the suppression of the metallic sectors and the use instead of several pairs of metallic wire brushes on the diagonal conductors. Machines so constructed have the disadvantage of not being self-exciting; but, on the other hand, the polarity of the electrodes when excited is quite under control, and the excitation is easily obtained by touching the moving ebonite for a few moments with the fingers. As we shall see later, this control of polarity is important in some applications—as, for example, in radiography.

In the combined friction and influence machine, constructed by Carré,\* the influence part of the machine was an ebonite disc, which rotated oppositely with one of glass.

A form of Wimshurst machine, which has been developed very much on the Continent, replaces the oppositely revolving glass plates by two oppositely revolving concentric ebonite cylinders. In a machine shown at the Paris Exhibition of 1900 the ebonite cylinders were 50 cms. high, and the outer one 50 cms. in diameter. The electrical connections were the same as in the plate machines, but no sectors were used on the moving cylinders. It was claimed that the output of the machine was considerably increased by the great surface of the active parts. The gear for driving the cylinders was contained in a central column. An electrically heated coil was supplied to dry the ebonite in damp weather.

**Later Wimshurst Machines.**—During the last few years Mr. Wimshurst has modified the influence machine already described by using plates revolving in one direction only, the inductors being fixed and supplied with proper neutralising and collecting brushes. One form of this modified Wimshurst machine is shown in Fig. 90. The fixed inductor plates A of varnished glass are fitted in the corners of the wooden frame F F; two plates are fixed on one side of the frame at opposite corners, and the other two on the other side at the remaining corners. Between these revolves a varnished glass plate of the usual kind, but either with or without sectors. In the machine illustrated the revolving disc is 40 cms. in diameter, and the wooden frame 50 cms.

\* Fully described on page 59 of the 1893 edition of this work.

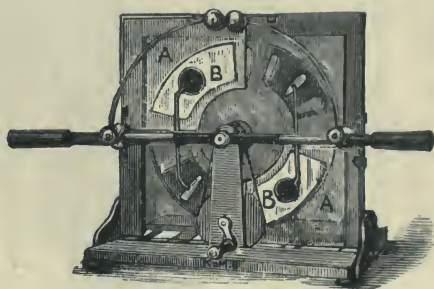

Fig. 91.—Improved Wimshurst Machine.

square. The fixed plates carry tinfoil inductors, as shown, and to these are fixed the wooden discs B, carrying light brass rods ending in



Fig. 92.—Large Wimshurst Machine with Fixed Inductors.

fine wire brushes which lightly touch the sectors of the revolving disc at the moment that these sectors are under the influence of the inductors



on the other side. When the machine is worked the potential difference of the inductors rapidly increases, and sparks alternately in opposite directions can be drawn from proper discharging rods. The complete machine, as made by Messrs. Griffin and Son, is shown in Fig. 91.

In still more recent machines the fixed plates are extended so that each covers about three-eighths of the active part of the revolving disc, instead of a quarter as in Fig. 92. In a machine exhibited at the Physical Society in 1893 (illustrated in Fig. 92, reproduced from *Engineering*) there were two revolving discs, each 41 inches in diameter and  $\frac{3}{4}$  inch apart. The inductors were sheets of paper attached to the fixed glass plates and each provided with two metallic contacts. The leading contact L (Fig. 92) was connected to the brush touching the revolving disc and to one of the outer terminals, whilst the trailing contact T could be cross-connected to the other inductor or not as desired. When so connected a steady current flows through the connecting wire when the machine is worked. If disconnected alternate discharges are given, as is also the case with the machine shown in Fig. 91.

In 1902 Lord Blythswood presented to the Glasgow Royal Infirmary a large forty-plate Wimshurst machine of the ordinary double revolving type, but embodying all the improvements developed during many years of experience with these machines. Considerations of space do not allow of a full description, for which readers sufficiently interested are referred to the *Electrical Review*.\* Briefly, it may be said that the plates are 3 feet in diameter, and that the driving shaft is 7 feet long. Tested on a very damp day, the machine gave a torrent of sparks from 12 to 15 inches in length. The machine was connected to a condenser of approximately 0.15 microfarad† capacity, with a discharging spark gap 0.75 cms. long, and it was found that the spark passed once in every six seconds. The size of the balls used for the spark gap was not given, but the spark length corresponds to a pressure of about 20,000 to 22,000 volts. Taking the lower figure, the experiment shows that the current from the machine was approximately 0.5 milliamperes.

Another direction in which it has been sought to increase the voltage of induction machines is by working them in an atmosphere in which the air has been compressed. It is a well-known fact, as will be shown more in detail later (*see* Chapter XVII.), that on reducing the air pressure the spark length for a given voltage is increased. Similarly, by increasing the air pressure the spark length is diminished or, putting it otherwise, the voltage required to produce a spark of

\* *Electrical Review*, Vol. 51, page 253, 15th August, 1902.

† The units referred to will be explained later.



given length is increased. Under increased air pressure also the tendency to brush discharges is diminished.

In 1900 Mr. F. Tudsbury applied these principles to the improvement of the influence machine specially with a view to the extension of its use for X-ray work. His machine—of which an external view as manufactured by Messrs. Townson and Mercer is given in Fig. 93—consists of

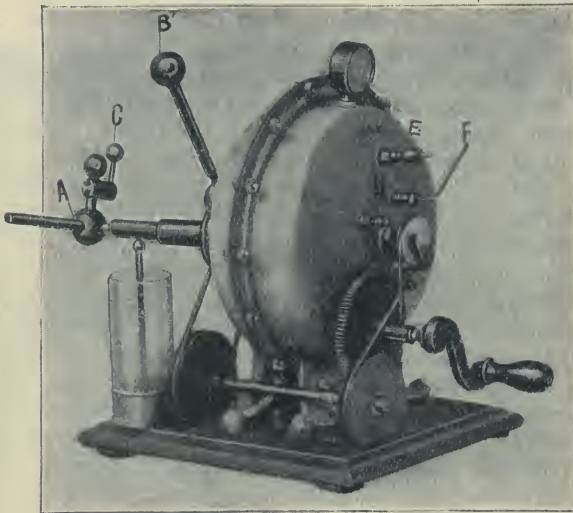

Fig. 93.—The Tudsbury Influence Machine.

two concentric cylinders, about  $6\frac{1}{2}$  inches in diameter, mounted so as to be capable of rotation in opposite directions. The cylinders are made of a material said to be superior to ebonite, both in regard to electrical properties and also to its non-deterioration by exposure to air and sunlight. The whole of the working parts, except the driving gear, are enclosed in a steel air-tight case provided with properly

packed glands or stuffing boxes for the electrodes, axles, etc.

The compressed air, which is pumped into the case, is dried before entry by being passed through a chloride of calcium tube, thus improving the insulation of the working parts, and the enclosing case is sufficiently effective to hold up the pressure with very little diminution for several days. The illustration shows one of the terminals A with the usual Leyden jar attached; the discharging ball B is fixed to the other terminal, which with its Leyden jar is hidden by the case of the machine. F is a handle by which the position of the neutralising brushes can be adjusted without opening the case, and E is the air-valve for connection to the compression pump.

The effect of using compressed air is shown in the following table, which gives the results of experiments with a machine having cylinders 8 inches in diameter, enclosed in a case 10 inches in diameter and  $4\frac{1}{2}$  inches long. The Leyden jars used were 2 inches in diameter and coated 2 inches high.

Pressure in atmospheres.	Approximate total pressure in lbs. per square inch.	Spark length in dry air.
1 Atmosphere (ordinary pressure)...	15	2½ inches.
2 Atmospheres .. ...	30	5 "
3 " ... ..	45	7 "
4 " ... ..	60	8 "

As will be seen later on in the chapter (page 130), the voltage required increases more rapidly than the spark length, but the actual voltage developed cannot be estimated in the absence of information regarding the diameter of the discharging balls.

Larger machines have been constructed having cylinders 15 inches in diameter enclosed in a case 20 inches in diameter and 10 inches long made of an aluminium alloy. In these machines the driving gear is placed inside the case.

#### VI.—STORAGE OF ELECTROSTATIC ENERGY (CONDENSERS).

Fixing our attention more on the dielectric, as the electrically active body, rather than on the charged conductors, we may regard the electric field as a space occupied by dielectrics and bounded by conductors. This space is in a state of strain, and whilst the electric field exists is a storehouse of energy. It is, therefore, both interesting and also practically important to consider how we may dispose of our dielectrics and the bounding surfaces (the conductors) so as to enable us to increase the amount of energy stored under given conditions of the production of electrification. For it is obvious that the greater the amount of energy we can store in a given space the greater will be the electrical or other effects produced when that energy is utilised and made to do electrical or other work.

Pieces of apparatus designed with this object are known as *condensers*, a singularly inappropriate term, since they condense nothing in the ordinary meaning of the term. It is true that they enable us to concentrate a large quantity of electrostatic energy in a comparatively small volume of dielectric, but energy is not material and therefore is not capable of condensation. The name arose from the fact that large electrical charges can be given to the conductors used; but then electricity, if regarded as a fluid, is certainly incompressible, and therefore cannot be condensed. The name, however, is so firmly fixed in the literature of the science that, with this preliminary caution, we shall use it, for no other is generally recognised.

A *condenser*, then, is usually defined as "two conducting surfaces op-

posed to one another and separated by a dielectric," but a better definition is that a condenser consists of a *dielectric bounded by two conductors insulated from one another, the capacity for storing energy being large for the volume of dielectric employed.*

**Potential.**—It has already been explained that the strain energy stored in the dielectric is derived from the work done in separating the electrical charges at the ends of the strain lines or lines of force. Thus, in Fig. 94, as the discs A and B are drawn apart, work is done against the electrical attractions, and the equivalent energy is stored in the intervening and neighbouring dielectric. In the two-fluid theory of electrification the discs are supposed to be charged with quantities of

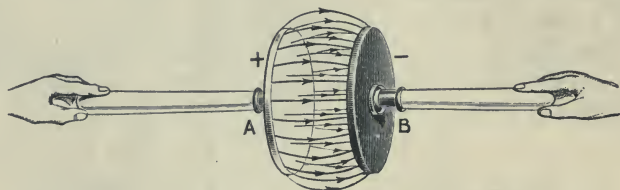

Fig. 94.—Strain Energy in the Dielectric.

electricity, the numerical estimation or specification of which is to be such as to satisfy Coulomb's fundamental equation—

$$f = \frac{q_1 q_2}{k d^2},$$

or

$$f = \frac{q_1 q_2}{d^2}, \quad \text{if } k = 1$$

It is evident that the quantities  $q_1$  and  $q_2$  so measured do not specify the amount of work done or energy stored in the dielectric, for, if no third conductor be present, these quantities remain the same whatever distance apart the discs may be. Still the amount of energy stored depends upon  $q_1$  and  $q_2$ , for these quantities fix the number of lines of force set up. The missing quantity—that is, the ratio between the work done  $w$  and the charge  $q$  (for  $q_1 = q_2$  in the case cited)—is known as the potential difference between the discs, or, more briefly, as the *potential*  $v$  of one disc A, if the other, B, be arbitrarily assumed to be at zero potential. Thus we have

$$v = \frac{w}{q}$$

or

$$w = qv$$

for the energy stored in the dielectric in this case.

If the disc B at zero potential be supposed to be fixed,  $w$  is the work



done in moving the + charge  $q$  to the position where it has the potential  $v$ . If  $q$  were diminished,  $v$  remaining unchanged, the work  $w$  ( $= qv$ ) would be correspondingly diminished. Thus we may say that  $v$  units of work are done on each unit of electricity in  $q$ , for this gives us the whole work done as equal to  $qv$ . Hence we derive the following definition of potential: *The potential  $v$  at any point is the work done in bringing to that point a unit of + electricity from any place at zero potential.* In fact, we may regard  $v$  as the energy required to stretch the  $4\pi$  lines of force corresponding to unit charge as the disc A is drawn away from B.

Conversely, the potential may be said to measure the energy with which a body charged with a unit of electricity tends to return to the place of zero potential and the work which it could do in so returning. A simple way of looking at the facts is to regard the + charges as tending always to move along the lines of force towards the negative charges, and the difference of potential between any two positions on a line of force is the work which a unit charge would do in passing in the positive direction along the line. Thus every point in the electric field has a definite potential, though the charges are only found at the ends of the lines. If the field be due to a quantity of electricity  $q$ , at a point A the potential at a distance  $r$  from A can easily be shown to be  $\frac{q}{r}$ .

Lines or surfaces connecting all the points at the same potential in

\* Suppose at a point A there is a quantity  $q$  of electricity, and let B and C be two points on the same line, at distances  $r$  and  $r + d$  from A, so that the distance BC is  $d$ . Let  $v_1$  and  $v_2$  be the potentials at B and C respectively due to  $q$  and A. Then the difference  $v_1 - v_2$  is the work done in bringing a unit of electricity from C to B.

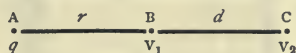

The force at B between two quantities,  $q$  and 1, is  $\frac{q}{r^2}$ .

The force at C is  $\frac{q}{(r+d)^2}$

Hence the work (force  $\times$  distance) required to carry 1 from C to B lies between  $\frac{qd}{r^2}$

and  $\frac{qd}{(r+d)^2}$ .

As these are very near together if  $d$  be small, we may take their geometrical mean as the quantity between them which we require.

$$\text{The mean} = \frac{qd}{r(r+d)} = \frac{q}{r} - \frac{q}{r+d}$$

$$\text{Hence } v_1 - v_2 = \frac{q}{r} - \frac{q}{r+d}$$

If  $v_1 = \frac{q}{r}$  then  $v_2$  to be of the same form must be equal to  $\frac{q}{r+d}$ , and this satisfies the equation. Therefore the potential at a point distant  $r$  from  $q$  is  $\frac{q}{r}$ .

the field are known as *equipotential lines or surfaces*. It is evident that they must be everywhere at right angles to the lines of force, for two points on any line of force are always at different potentials, since work must be done in passing from one to the other. These equipotential surfaces will therefore represent differences of electrical level, and  $\pm$  electricity will always tend to flow from the surface at the higher potential to the surface at the lower potential, and will so flow if these surfaces

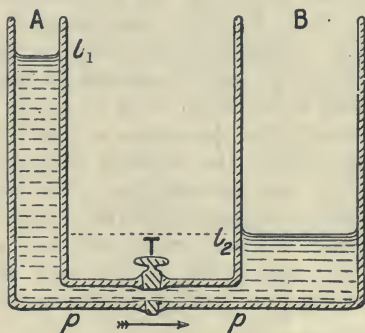

Fig. 95.—Flow caused by Difference of Level.

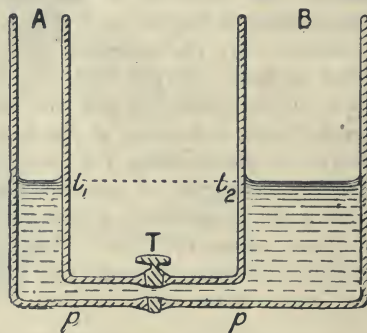

Fig. 97.—Levels equal : no flow.

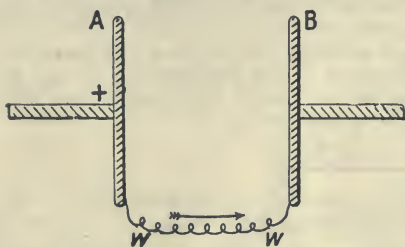

Fig. 96.—Flow caused by Difference of Potentials.

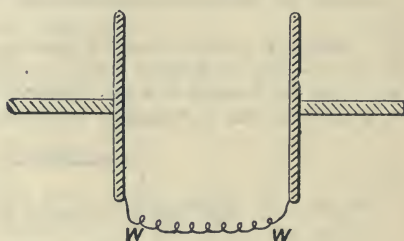

Fig. 98.—Potentials equal : no flow.

are connected by a conductor. The case is mathematically analogous to the flow of water between two water-tanks A and B, Fig. 95, with different levels. If the tanks be connected by a pipe  $\rho\rho$ , the discharge of water from one to the other takes place because of the difference of level; water flows from the tank A which has the higher level  $l_1$  to the tank B in which the level  $l_2$  is lower. When the levels  $l_1$  and  $l_2$  have become equal as in Fig. 97, no further flow will take place. In the case of electricity we employ similar language, but use the word *potential* instead of *level*. The electrical cases analogous to Figs. 95 and 97 are shown in Figs. 96 and 98. In Fig. 96 the plate A is supposed to be at a high (or  $\pm$ ) potential, and the plate B at a lower

(or  $-$ ) potential. If these plates are connected by a wire  $w w$  there will be a flow of electricity through the wire as long as the potential of  $A$  is higher than that of  $B$  (in practice this flow is almost instantaneous). But if, as in Fig. 98, the plates  $A$  and  $B$  are both at the same potential (say both equally  $+$ ), then on connection being made between them by a wire  $w w$  no flow of electricity will take place in the wire.

If the stopcock  $r$  (Fig. 95) be closed whilst there is still a difference of level between the tanks  $A$  and  $B$ , the material of the stopcock will be put in a state of strain, due to the different pressures on the two sides. But if the stopcock  $r$  in Fig. 97 be closed, no such state of strain will be set up in the material of the stopcock. The closing of the stopcock breaks the hydraulic connection between the tanks, and in the electrical cases is equivalent to the removal of the wire  $w w$ . In Fig. 96 this would leave the dielectric in the space between  $A$  and  $B$  in a state of strain, whilst in Fig. 98 no such strain would be set up.

If, when two bodies are connected by a wire or brought into contact, positive electricity passes from one to the other, we say that there was a difference of electrical potential between them, and that the body from which the positive electricity passed had the higher potential. When no water flows from one tank to another on connection being made between them, we know that they must be at the same level, as in Fig. 97; and similarly if no discharge takes place between two bodies when they are electrically connected they must be at the same potential. Conversely, if they are at the same potential no discharge of electricity will be brought about by connecting them. If we can find a level of reference, we may speak of each tank as having a certain level, as, for instance, so many feet above or below high water mark. Similarly, we may speak of a body as having a certain potential if we assume the potential of the earth to be zero. When water falls to a lower level it will do work, and when it has fallen from a higher to a lower level the difference of level cannot be restored without the expenditure of work. For every pound of water that is lifted through a difference of level equal to a foot, one foot-pound of work is done, no matter what is the shape of the path by which the transfer to the higher level is effected. If  $Q$  be a quantity of water and  $D$  a difference of level through which it is raised, then the work done is  $QD$ . Similarly, electricity cannot be transferred from one body to another at a higher potential without requiring work to be done. If  $q$  be the quantity of electricity and  $v$  the difference of potential, the work required to transfer  $q$  up to the higher potential is  $qv$ .

The practical zero of potential is that of the earth; hence for practical purposes the potential of a body is considered to be the excess or defect of its potential above or below that of the earth in its neighbourhood.

**Condensers.**—Returning to the definition on page 110, it is obvious that the shapes of the conductors and their positions relatively to the



dielectric and to one another admit of a wide range of choice, especially for experimental work on the effects of varying the conditions. One special form for such work, used by Reiss, is shown in Fig. 99, where *s* and *t* are insulating columns, and *A* and *B* the conductors, the dielectric being air; connecting one of the plates to earth the potential\* set up in the other by a fixed charge can be measured, and the effect produced by varying the distance of the plates by a known amount can be observed.

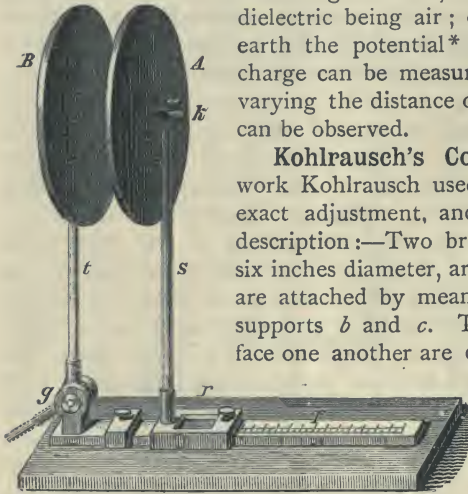

Fig. 99.—Reiss' Condenser.

**Kohlrausch's Condenser.**—For more accurate work Kohlrausch used a condenser admitting of very exact adjustment, and of which the following is a description:—Two brass plates *t t* (Fig. 100), of about six inches diameter, are fixed to horizontal rods, which are attached by means of shellac to the two wooden supports *b* and *c*. Those sides of the plates which face one another are covered with gold, and the ends of the rods are provided with binding screws to receive conducting wires. The supports, together with the plates upon which they rest, stand upon the large base plate *a*, upon which the whole apparatus rests.

The base plate can be adjusted horizontally by means of levelling screws. The support *b* can be moved towards *c* by means of two

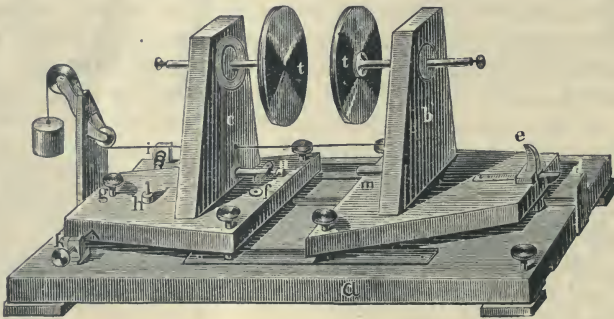

Fig. 100.—Kohlrausch's Condenser.

forks attached to the under side. A silk thread passing over two pulleys has one end attached to *b*, and its other end to a weight, thus tending

\* Instruments for measuring potential or potential differences will be described later.

to move  $b$  towards  $c$ . The spring  $d$  and the catch  $e$  serve to liberate  $b$ , or to arrest its motion.

The support  $c$  is not movable forward towards  $b$ , but is provided with adjusting screws to bring the conducting plate attached to it parallel to the conducting plate attached to  $b$ . The turning of  $c$ , and therefore the motion of the plate underneath it, is effected by means of the screw  $k$  and the spring  $i$ ; whilst  $c$ 's vertical inclination can be changed by means of the screw at  $g$  and the spring at  $h$ . The distance between the conducting plates can be altered by simply turning the screw  $n$ .

For laboratory purposes Professor Ayrton has designed condensers in which the size of the surfaces of the conductors, consisting in this case of sheets of tinfoil, can be varied as well as their distances apart. With these the laws of the influence of the geometrical shape of the dielectric can be still further investigated.

Experiments with the above and other apparatus prove that the potential to which a certain charge will raise the insulated plate of the condenser depends upon the sizes of the plates and their distance apart. For definiteness it is usual to define the *capacity* of the condenser as the *charge which will produce unit difference of potential between the plates*, though it is quite evident that much larger charges can be given to most condensers producing a correspondingly increased potential difference. In fact, with the plates and dielectric fixed, the potential difference  $v$  rises proportionately with the charge  $Q$ , and we have

$$Q = K V$$

where  $K$  is the capacity of the condenser as above defined.

The condensers so far described all have ordinary air for the dielectric, but Cavendish, about 1775, showed that the capacity for a condenser depends not only on its geometrical shape and dimensions, but also on the dielectric employed, and that the capacity is greater when solid dielectrics take the place of air. Cavendish's results were not published at the time, and Faraday in 1837 independently investigated the phenomena; his researches may be said to form the starting point of our present knowledge of the subject. They proved conclusively the importance of the part played by the dielectric in electrostatic action; and in connection with them Faraday put forward his theory of the electric field.

The property of the dielectric which affects the capacity of a condenser in which it is used is called its *specific inductive capacity*, a somewhat clumsy and not very happy term; *inductivity* has been suggested instead, and is much better, as it corresponds to conductivity in conductors. Numerically the specific inductive capacity of any dielectric is the ratio between the capacities of two condensers exactly similar but having the given dielectric and ordinary air respectively for their dielectrics. Thus the capacity of any condenser depends on two factors: one the geometrical factor  $G$ , determined by the size and shape of the conductors and their distances apart, the other

the specific inductive capacity  $k$  of the dielectric. Thus we have the actual capacity

$$K = kG.$$

According to the above definition  $k = 1$  for air. This quantity  $k$  is the same as that which appears on page 64 in the fundamental equation for the force acting between two charged particles. The geometrical factor  $G$  in a condenser of the shape shown in Fig. 105 is increased by increasing the size of the plates and by diminishing the distance between them.

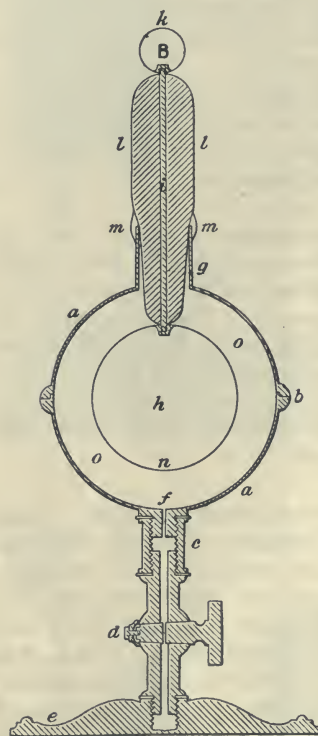

Fig. 101.—Faraday's Spherical Condenser.

In his experiments on specific inductive capacity, Faraday used two exactly equal condensers constructed as shown in Fig. 101. A brass ball  $h$  was held in the centre of a large hollow sphere  $aa$  by means of a brass rod  $i$  passing upwards through a neck  $g$ , in which was fixed a long insulating plug of shellac  $ll$ . The brass rod terminated in a knob  $B$ . The hollow sphere was divided into two hemispheres, the upper one of which could be removed to allow the material under experiment to be introduced. The bottom hemisphere was also pierced and connected with a tube through the stand by which different gases could be introduced or a vacuum created in the space between the spheres. The method of experiment consisted in charging one of the condensers and then making it share its charge with the other by connecting the inner balls; the fall of potential involved was examined. If the capacities were equal the fall of potential would be exactly one-half the original potential, be-

cause the capacity would be doubled on connecting the two, whilst the charge would remain unchanged. If the capacities were unequal the fall would not be exactly one-half, and from the excess or defect the ratio of the capacities could be calculated. This ratio would be the specific inductive capacity of the dielectric, since one of the condensers was an air condenser.

Subsequent investigators have experimented by different methods on the values of the specific inductive capacity of various dielectrics; some of the results are given in the following table:—



Ethyl alcohol ... ..	25.0	Paraffin ... ..	2.0
Solid cellulose ... ..	7.4	Petroleum... ..	2.0
Mica ... ..	5.5 to 8.0	Turpentine ... ..	2.2
Glass ... ..	3.0 to 6.0	Benzine ... ..	2.3
Shellac ... ..	2.7 to 3.3	Paper (dry) ... ..	1.7 to 2.5
Sulphur ... ..	2.58	Carbon dioxide ..	1.0008
Guttapercha ... ..	2.46	Air ... ..	1.0000
Indiarubber ... ..	2.2 to 2.5	Hydrogen... ..	0.9998
Ebonite... ..	2.28		

In the case of solids the values given depend on the physical state at the time of the experiment and also on the duration of the electrical charge.

**The Leyden Jar.**—The discovery of the Leyden jar, which is a form of condenser, has already been referred to in our historical introduction

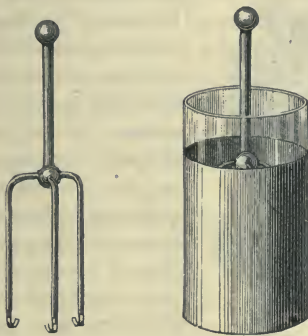

Fig. 102.—Leyden Jar.

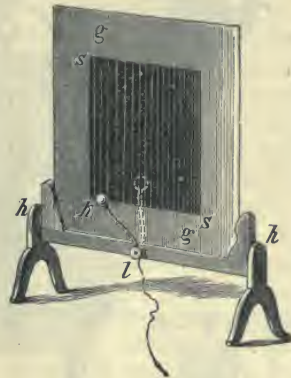

Fig. 103.—Franklin's Pane.

(page 8). A good form is shown in Fig. 102, and consists of a glass cylinder coated with tinfoil inside and outside to about two-thirds of its height. The stiff brass rod with a knob at the top is supported on the three slightly flexible legs as shown, these legs coming into contact with the tinfoil when placed in the jar. The method of construction is simple, and if the exposed glass be kept dry the insulation is excellent. The two tinfoil coatings are the conductors, and the glass between them is the working dielectric. Usually, to charge the jar the outer coating is earthed or connected to one of the discharging knobs of an electrical machine, whilst the other is connected to the other knob. The ends of the lines of force set up between the knobs of the machine then sweep down the conductors, and the lines themselves are transferred to the glass in great numbers.

**Franklin's Pane.**—Franklin, subsequently to the discovery of the Leyden jar, constructed the condenser shown in Fig. 103, and known as Franklin's pane. The wooden frame *h* carries a glass plate *g*, covered for the greater part of both sides with tinfoil *s s*. To charge this pane, the

coating on one side is connected with the source of electricity, the other has a wire leading to earth; when  $kl$  is moved into the position shown by the dotted lines,  $k$  touches the tinfoil, and connects this tinfoil to earth by means of the wire which supports  $k$ .

**Batteries of Jars.**—To obtain very powerful effects, we might use very large jars or plates; this, however, would be inconvenient, and the method adopted is to connect several jars in a form called a battery, by electrically

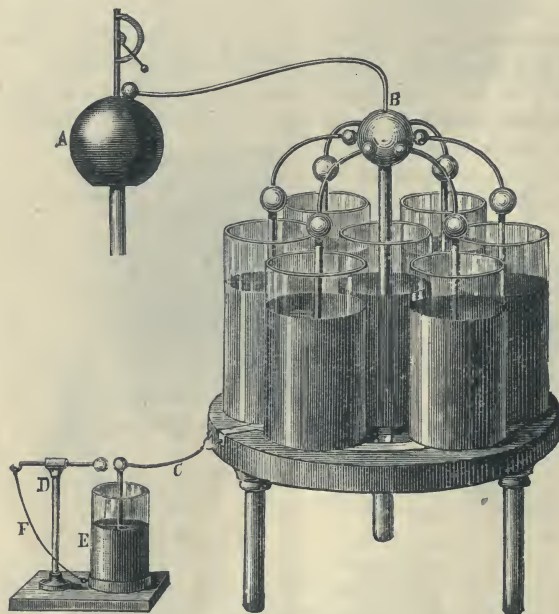

Fig. 104.—Battery of Jars.

connecting all the inner coatings to form one conductor of large surface, and also electrically connecting the outer coatings as shown in Fig. 104. The charge of such a battery with a given potential of the inner coatings increases proportionally with the number of jars; for instance, eight equal jars will have a charge 4 times that of two jars. A table resting on glass supports has brass bands on its upper surface, so arranged that all the outer coatings of the different jars are touched by them. The knobs

of the jars have metal rods terminating in balls. The knob of the centre jar  $B$  is bigger than the remaining ones, and to it the metal rods are fastened. On  $B$  is an arm terminating in a little ball; to charge the apparatus this ball is placed on the prime conductor  $A$  of an electrical machine, whilst the outer coatings are connected with the earth. With the machine worked at a constant speed the time required to charge this apparatus will be  $x \times$  the number of jars, if  $x$  stands for the time in which one jar is charged, and they are all similar. The whole apparatus, however, might be charged in  $x$  seconds  $\div$  the number of jars; to do this, each jar is separately insulated; a wire from the outer coating of the first jar leads to the inner coating of the second, a wire from the outer coating of the second leads to the inner coating of the third, and so on, until the last

jar is reached, the outer coating of which is in connection with the earth, and the inner coating of the first jar is brought into contact with the source of electricity. A battery arranged in this manner is termed a cascade battery, and a series of jars so connected is said to be charged in cascade.

The capacity of the arrangement is  $\frac{1}{n^{\text{th}}}$  the capacity of a single jar if  $n =$  the number of jars. The thinner the glass in the jar the more electric energy will it store for a given *difference of potential* between its plates; but care must be taken that the glass be not too thin, else the dielectric will give way under the severe stress, there will be a disruptive discharge, and a hole will be pierced through the glass; if this happens the jar will be rendered useless. If, however, the glass should be pierced the jar may be used again, provided the tinfoil round the hole be removed.

**Lane's Unit Jar.**—To the left of Fig. 104 there is shown a little piece of apparatus known as Lane's unit jar. It consists of a small Leyden jar  $\epsilon$ , which rests on a conducting substance connected to earth; close to it is the glass pillar  $\delta$ , fitted with a piece of brass in which a horizontal brass rod slides; one end of this brass rod terminates in a little ball, the other end holds a small wire  $f$ , which is fastened to the conducting substance on which the jar rests. The wire  $c$  connects the inner coating of the little jar with the insulated outer coating of the battery. The jar serves the purpose of determining the quantity of the charge of the battery, or indirectly the difference of potential between the coatings. The distance through which a spark will pass when a conductor is brought near an electrified body depends upon their difference of potential; it follows that when this distance remains the same, and the capacity of the condenser, of which the two balls form the terminals, is also unchanged, the number of sparks will enable us to determine approximately the quantity of electricity discharged.

The arrangement shown consists of two condensers in cascade, one being the large battery and the other the unit jar. There are therefore three separate sets of conductors. First, the inner coatings of the battery, which are in connection with  $A$ ; secondly, the outer coatings of the battery and the inner coating of the jar—these are insulated; thirdly, the earthed outer covering of the jar. When charging is going on (assuming it to be giving  $+$  electrification) the potential of the second conductor rises, because it is under the inductive action of both the earth and the first conductor. It eventually rises sufficiently for a spark to pass when it falls to zero, discharging the  $+$  electrification on the inner coating of  $\epsilon$ , but leaving the  $-$  electrification on the outer coatings of the battery. It then rises again and discharges, leaving a second equal quantity of  $-$  electrification on the outer coatings of the battery, and so on; and if this distance be kept constant discharge will always take place at one and the same difference of potential. The number of sparks passing will therefore indicate the quantity of the charge of the battery; dividing the number of



sparks by the number of jars contained in the battery gives the quantity per jar. The unit thus obtained represents that amount of electricity which charges the unit jar to the potential difference necessary to cause *one* spark to pass. In this kind of measurement certain precautions are necessary.

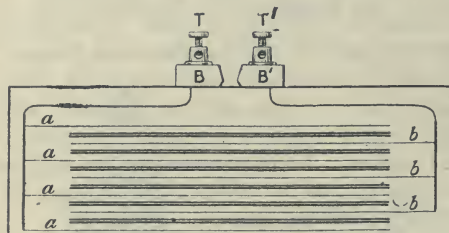

Fig. 105.—Condenser, ordinary Type (Section).

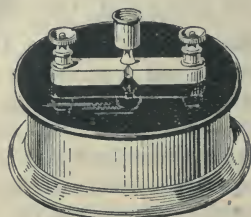

Fig. 106.—Standard Condenser.

The battery must not be charged by allowing sparks to pass from the conductor A. Before measurements are taken with the jar E, we must allow it to be charged and discharged once, on account of the residual charge which is left behind in Leyden jars after they are discharged.

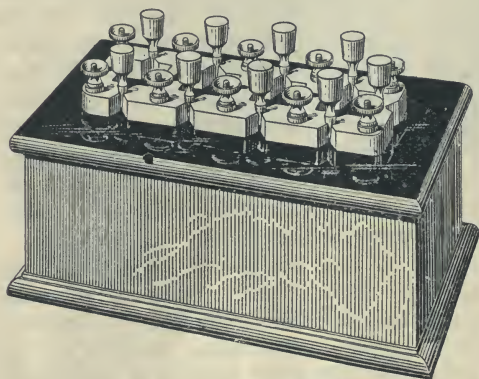

Fig. 107.—Box of Condensers.

### Standard Condensers.

—The Leyden jar, after being for many years only of theoretical interest, is now coming into practical use in connection with induction machines used for the production of X-rays and in radiography. But other forms of condensers have been and are widely used in the applications of electricity, especially in

telegraphy. The object of the design of these condensers is to obtain great storage capacity in a small space, whilst the insulation of the conductors is carefully attended to. The conductors used are almost invariably sheets of tinfoil built up as shown in Fig. 105 and separated by layers of mica or of paraffined paper. The former is the better dielectric, but is only used for the highest class of work on account of the expense. In the figure the fine horizontal lines *a a a a* and *b b b b* represent the conductors, and the heavy lines the dielectric. The sheets of tinfoil are so cut, either with suitable lugs or otherwise, that the alternate ones *a a a a* can be conveniently joined

together on the left-hand side, and the intermediate ones  $b b b$  similarly joined on the right-hand side. When the requisite number has been reached they are pressed firmly together and placed in a suitable box, on the outside of which are mounted two terminal blocks  $B B'$ , on which are suitable terminals  $T T'$ . The blocks are usually separated by a conical hole in which a plug can be inserted to "short-circuit" or discharge the condenser.

In Figs. 106 and 107 are shown two such commercial condensers as used for testing purposes. Fig. 106 may be regarded as the external view of the condenser shown in section in Fig. 105, with the difference that in this pattern, which is usual for a standard condenser of  $\frac{1}{3}$  of a microfarad, the terminal brass blocks are lengthened as shown. In Fig. 107 the box contains five separate condensers, having capacities of '05, '05, '2, '2 and '5 microfarad respectively; the ten external terminal blocks are so arranged that the separate condensers can be rapidly joined up in series or in parallel, or partly in series and partly in parallel. A diagrammatic plan of the box is

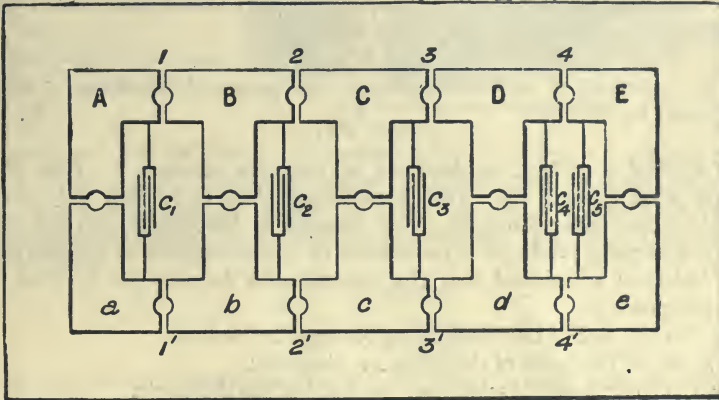

Fig. 108.—Plan of Condenser Box.

given in Fig. 108. Ten brass blocks,  $A \dots E$ ,  $a \dots e$ , are arranged facing one another in pairs— $A a$ ,  $B b$ , etc.; the blocks  $A a$  are the two terminals of the first condenser  $c_1$ , the blocks  $B b$  the terminals of the second condenser  $c_2$ , and so on. Each block can be electrically connected, by a conical plug inserted into the dividing space, with the block opposite to it and with the blocks on either side of it. When connected to the opposite block the corresponding condenser is short-circuited and cannot be charged. When connected to the blocks on either side the plates of the adjacent condensers on that side form electrically a single conductor. To join the condensers in parallel, holes 1, 2, 3 and 4 should be plugged on one side, and

holes 1', 2', 3' and 4' on the other. To join them in series, holes 1, 2', 3 and 4' should be plugged and terminals  $a$  and  $\epsilon$  used. To avoid confusion, the binding screws shown in Fig. 106 have been omitted from the diagram in Fig. 108.

A form of standard condenser very convenient for testing purposes, as made by Messrs. Muirhead and Co., is shown in Fig. 109. The  $\frac{1}{2}$  microfarad is divided into two condensers having three terminal blocks, A, B, and C, of which C is common to each condenser. This arrangement enables the capacities of the two to be compared from time to time, so that any alteration in one of them would be detected.

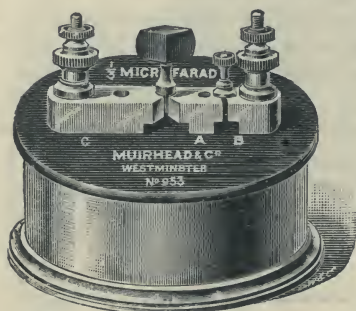

Fig. 109.—Subdivided Standard Condenser.

**Theory of the Condenser.**—This will be a convenient place to collect and amplify the facts already explained respecting condensers.

If  $\kappa$  be the capacity of any condenser, and if a quantity of electricity  $Q$  raise the potential-difference of its two conductors by  $v$ , then

$$Q = \kappa v. \quad (A)$$

If without altering  $Q$  we diminish  $\kappa$ , then we increase  $v$ . Now this is exactly what is done with Volta's condenser (Fig. 135) when duly charged and the upper plate lifted off. The capacity is diminished, and the higher potential thereby produced is manifested by the divergence of the leaves.

It has been mentioned that the capacity of a Leyden jar or other condenser depends—

- (1) On the size of the conducting coatings or surfaces.
- (2) On the thickness of the glass or dielectric.
- (3) On the "specific inductive capacity" of the dielectric.

More generally we have seen that the capacity consists of two principal factors: one,  $G$ , a purely geometrical factor, depending on the sizes and relative positions of the conductors, and the other,  $k$ , depending on the nature of the dielectric and known as its "specific inductive capacity," so that we have

$$\kappa = kG. \quad (B)$$

It will be useful to record here the values of  $G$  for a few typical cases of practical importance.

For two parallel plates at a distance  $d$  apart, and where  $s$  is the acting surface of one of the plates, we have, if  $s$  be very large compared with  $d$ ,

$$G = \frac{s}{4\pi d} \quad (1)$$

This is the case of the ordinary working condenser (Figs. 105 to 109) just



described, and the formula may also be used to give approximately the geometrical factor for a Leyden jar. Notice that the capacity will vary *directly as the acting surface and inversely as the distance apart of the plates*. Hence the importance of bringing the plates as close together as possible.

For *two concentric spheres* of radii  $a$  and  $b$  respectively,

$$G = \frac{ab}{a-b} \quad (2)$$

This is the form of condenser (Fig. 101) used by Faraday in his classical researches. Here again  $a-b$  is the distance apart of the acting surfaces, and the capacity increases proportionately with the diminution of this distance.

A very important case is that of two concentric cylinders of length  $l$ , and with radii  $r_1$  and  $r_2$  respectively, shown in section in Fig. 110. This represents

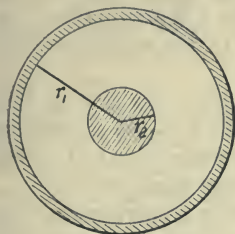

Fig. 110.—Section of Condenser formed by Two Concentric Cylinders.

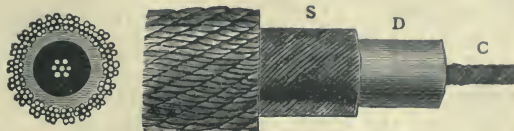

Fig. 111.—The First Atlantic Cable.

the condenser formed by a submarine cable (*see* Fig. 111), where the inner cylinder ( $r_1$ ) is the copper conductor  $c$ , and the outer cylinder the inner surface of the outer conducting sheath  $s$ , the space between being filled with some dielectric  $d$ , such as guttapercha, used as an insulator. Here we have

$$G = \frac{l \times 4343}{2 \log. \frac{r_1}{r_2}} \quad (3)$$

In this formula the logarithm of  $\frac{r_1}{r_2}$  can be taken from an ordinary table of logarithms in the usual way.

*Unit of Capacity.*—To obtain the actual capacity of any condenser by using the formulæ (1), (2), and (3), it should be noted (i.) that all measurements must be made in centimetres, and (ii.) that the result obtained must be divided by 900,000. The capacity will then be given in *microfarads*, the practical unit of capacity in the electro-magnetic system to be explained later.

*Energy Stored in a Charged Condenser.*—We have seen (page 110) that the energy  $w$  stored in a charged condenser depends on the product of the charge  $Q$  and the potential difference  $v$ . In the case then considered the charge was constant, and the potential difference was varied by varying the capacity. In the more usual case the capacity is constant, and the charge and potential difference vary together. In this case the energy stored is

obtained by multiplying the charge by the *mean value* of the potential difference during the period of charging. Thus we have

$$W = Q \times \frac{1}{2} V = \frac{1}{2} Q V \quad (C_1)$$

Combining this with equation (A) we get either

$$W = \frac{1}{2} K V^2 \quad (C_2)$$

or

$$W = \frac{1}{2} \frac{Q^2}{K} \quad (C_3)$$

All these results are important. Equation (C<sub>1</sub>) is the general case. Equation (C<sub>2</sub>) is applicable when a Leyden jar or other condenser is being charged by an electrical machine or a battery where the final potential difference or electric pressure either approaches a certain limit or has a definite value. In these cases the energy stored is directly proportional to the capacity of the condenser.

Equation (C<sub>3</sub>) is applicable when the charge  $Q$  is fixed, and it is at first sight curious that then the energy stored varies *inversely* as the capacity of the condenser. In such a case the largest amount of energy would be stored by using the fixed charge  $Q$  to charge a condenser of very small capacity.

It should not be overlooked that the energy stored is proportional to the *square* of the potential difference or the *square* of the charge wherever the capacity of the system charged is constant.

*Combinations of Condensers.*—If condensers having capacities  $k_1, k_2, k_3,$  etc., be combined by joining all the conductors on one side together to form one big conductor on that side (*see* Fig. 104), and all the conductors on the other side to form another big conductor, the joint capacity  $K$  is the sum of the separate capacities, or

$$K = k_1 + k_2 + k_3 + \text{etc.} \quad (D_1)$$

This method of combination is technically known as joining in *parallel*. The result is obvious if we suppose the combination charged, and remember that all the condensers are charged to the same potential difference ( $v$ ), and that the total energy is the sum of the energies in the separate jars. Thus,

$$W = w_1 + w_2 + w_3 + \dots$$

or

$$\frac{1}{2} K v^2 = \frac{1}{2} k_1 v^2 + \frac{1}{2} k_2 v^2 + \frac{1}{2} k_3 v^2 + \dots$$

from which equation (D<sub>1</sub>) follows.

If, however, the condensers be joined in *series* (or "cascade") the law is more complicated. In this case the terminal of one condenser is joined to one of the terminals of the next, the other terminal of that to a terminal of the next one, and so on, so that the condensers are arranged in a single row, with a free terminal at each end to form the terminals of the system. We then find the combined capacity by the equation

$$\frac{1}{K} = \frac{1}{k_1} + \frac{1}{k_2} + \frac{1}{k_3} + \text{etc.}, \quad (D_2)$$

and it is easy to show that  $K$  is less than the least of the quantities  $k_1, k_2, k_3,$  etc. The truth of this equation can be proved in the same manner as before if we now remember that the *charges* of all the jars are equal. Thus,

$$W = w_1 + w_2 + w_3 + \dots$$

therefore

$$\frac{1}{2} \frac{Q^2}{K} = \frac{1}{2} \frac{Q^2}{K_1} + \frac{1}{2} \frac{Q^2}{K_2} + \frac{1}{2} \frac{Q^2}{K_3} + \dots$$

from which (D<sub>2</sub>) follows by dividing out  $\frac{1}{2} Q^2$ .

*Electric Absorption and Residual Charge.*—An important difference has to be noticed between a condenser with a gaseous and one with a solid dielectric, namely, that the first is fully charged almost instantly, the second takes time. If the knob of a Leyden jar, or one plate of any such condenser, be connected with an electric machine or generator, the other plate being in connection with the earth, a charge rushes in with great rapidity; but the passage of the electricity does not instantly cease, as is the case with an air condenser. Similarly, when the two plates are joined by a wire so as to be brought to one potential, the electricity is discharged very rapidly at first; but this discharge does not then cease, and the electricity continues to flow along the connecting wire for precisely as long a time as it ran in, and at the same rate after equal intervals of time. This further discharge is often referred to as being due to the "residual charge" of the condenser. If upon maintaining a difference of potential  $v$  between the coatings of the condenser a quantity  $Q$  per second is found flowing into the condenser at the expiration of a certain time, say, ten minutes, then ten minutes after the first discharge the same quantity  $Q$  per second will be found flowing from one coating or plate to the other. The dielectric seems to absorb electricity at a certain rate when subjected to certain conditions, and to yield it all up again at the same rate when the two plates are brought to the same potential.

To explain this action attention has been called by Faraday and other physicists to the analogous phenomena of "fatigue" and "elastic recovery" which are exhibited by many solids when subjected to mechanical stress. Thus if a bar of steel be placed in a testing machine and subjected to a tensile stress it is stretched perceptibly when the load is first applied. If, however, the load be kept on, the steel is very slowly stretched still further. On removing the load the bar springs back, if it has not been overstrained, *almost*, but not quite, to its original length, which will only be reached after a period of time approximately equal to the period that the load was kept on. Now the dielectric, we know, is mechanically strained by the electric forces, and it would appear as if the results of the application of the electric stress to the solid dielectric resembled very closely the case of the steel bar under mechanical stress. There is a large amount of yielding when the stress is first applied, followed by a slow and diminishing subsequent yielding, and *vice versa* when the strain is removed.

Maxwell has suggested that the phenomena are due to the dielectric being composed of heterogeneous particles of different conductivities, and has shown mathematically that this would account for the main facts. Dr. S. P. Thompson has further pointed out that all such



phenomena, both mechanical and electrical, may be due to heterogeneity of structure. It has been observed that a residual charge only remains when the dielectric separating the two coatings is a rigid body, and that the amount of this charge depends upon the properties of this rigid dielectric. It has been further found that the residual charge increases with the thickness of the dielectric and the magnitude of the charges given to the coatings. From these facts we must conclude that the dielectrics are the cause of these phenomena of residual charge.

**Seat of the Charge in a Condenser.**—Closely connected with the foregoing is the question of the exact position of the charge in a condenser. Do the charges, that is, the ends of the lines of force, lie on the surfaces of the conductors or do they lie on the contiguous surfaces of the dielectric? The two surfaces are infinitely close to one another, but they are geometrically different, and the above question is of great theoretical interest.

To examine the matter experimentally condensers have been constructed in such a way that the two conductors and the dielectric can be taken apart. Let a Leyden jar (Fig. 112) of this kind be charged and placed on an insulating table, and then let the inner coating *a* be first lifted out by an insulating silk cord and the glass *c* taken out from the outer coating *b*.

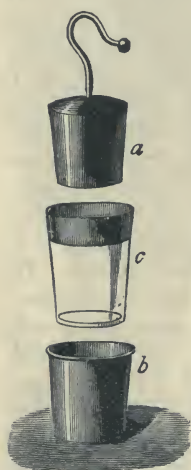

Fig. 112.—Leyden Jar with Movable Coatings.

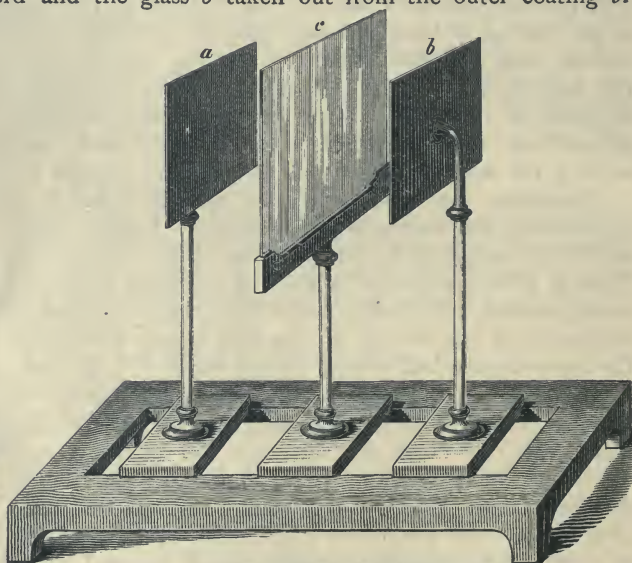

Fig. 113.—Condenser of Cæpinus, with Movable Coatings.

The two coatings may now be rubbed or brought together, and yet when the parts are replaced the jar will be found to be charged. It seems as if the charges had remained on the surfaces of the glass. A plate condenser which can also be readily taken to pieces is shown in Fig. 113, in which *a* and *b* are

the two coatings, made of sheet brass, supported on movable glass pillars. The glass plate *c* represents the dielectric. When *a* and *b* are pushed close to *c* the apparatus becomes a Franklin plate, and in this position the condenser is charged; when *a* and *b* are moved from *c*, both appear electrified, the one positively, the other negatively. The two plates are discharged, and again moved close to *c*; the plates again appear electrified, though not so much as before. It seems, then, that the greater portion of the charge resides within or on the surface of the glass plate. The above was Faraday's explanation, which was objected to by Kohlrausch, Clausius, and others, who consider the residual charge to be an inductive phenomenon. But from the point of view advocated in the foregoing pages, and remembering that the electrical *energy* is certainly stored in the dielectric, the fact that with solid dielectrics the strain lines appear to terminate at the surface of the dielectric, and not on the contiguous conductor, is not very surprising.

#### VII.—ELECTRICAL DISCHARGE AND SOME OF ITS EFFECTS.

**General Phenomena connected with Discharge.**—If we connect an electrified body by means of a wire with the earth, it loses all its electricity—that is, in the language of the fluid theory, the electricity of the body flows through the wire to the earth. The actual changes in the electric field have been described in detail for a special case (page 81), and it is easy to modify the description for any other case. In the case considered the—ends of the lines sweep upwards over the wire *x* (Fig. 66), and this, according to our present conventions, is regarded as an electric current *downwards* through the wire. The discharge of the positively charged body *k* therefore causes a current to flow downwards through the earth-connected wire *x*. We assume the potential of the earth to be equal to zero, and between it and all conductors at a different potential there will be an electric field. When a body has a potential differing from that of the earth, and is connected with the earth by a wire, electricity flows along the wire from the higher potential to the lower. The electricity flows until both bodies have the same potential, that is, until all the electric lines passing from one to the other have disappeared. The discharge of a Leyden jar is essentially similar. Here the connection is again between two conductors at different potentials, viz., the inner and the outer coatings of the jar. As in the previous case, as soon as the connection is made electricity flows from the conductor at higher potential to the conductor at lower potential, and the jar is discharged. During discharge electricity flows through the connecting wire from one coating to the other, producing what is called a current in the wire. But a current is produced even when an unelectrified body is brought near an electrified one before connection, as we have seen in the above-cited example. The moment we bring an unelectrified wire near the electrified body a current is induced in the wire by the redistribution of the lines of force, and before the wire has

reached the electrified body we see a spark pass. When the potential-difference of the electricity on the coatings has become sufficiently great to break down the resistance of the air, discharge takes place (see page 82). The distance which the spark overleaps is called the sparking distance; this distance, of course, depends upon the difference of potential produced. That is to say, the strain on the dielectric, or tendency to produce disruptive discharge through the air between two surfaces, depends upon their difference of potential.

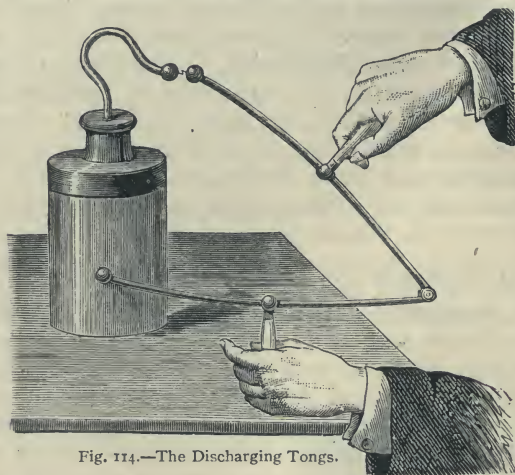

Fig. 114.—The Discharging Tongs.

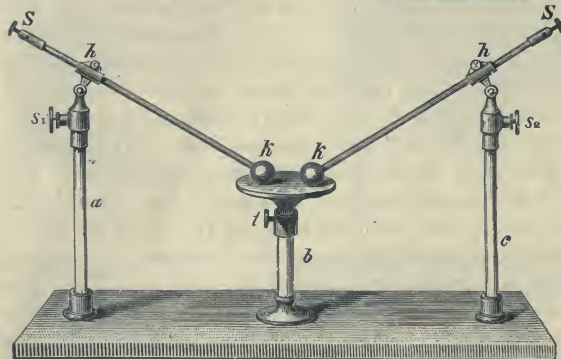

Fig. 115.—Henley's Discharger.

To discharge a Leyden jar the apparatus shown in Fig. 114 is usually employed. The rods connecting the balls are of metal, but the handles are of some insulating substance, generally of glass. The outer coating of the jar is touched by one of the balls, the remaining ball is approached to the knob of the jar until a spark passes over. If, however, we wish to observe the effect of the discharge on interposed bodies, the apparatus represented in Fig. 115 will be found more convenient, where insulating handles  $s_1$  and  $s_2$  direct, through slides and universal joints  $h h$  supported by insulating pillars  $a c$ , the discharging knobs  $h h$ . The substance through which the discharge is to be passed is laid on the little table adjusted by the screw  $t$  on an insulating pillar  $b$ . Wires from the oppositely charged conductors are attached to  $s_1$  and  $s_2$ .

**Sparking Distances in Air.**—To determine the sparking distance, an early method was to use the spark-micrometer of Reiss. It is represented in Fig. 116, where  $A$  is a heavy metal stand on which a metal



plate is fastened horizontally; a glass pillar is fixed to one end of the plate, the other end has a slide, which is moved along by means of a micrometer screw; this slide carries another pillar. To determine the sparking distance, the slide with the pillar is gradually moved towards the fixed one until the spark passes. The distance of the two balls from each other is indicated by a scale along which the slide is moved by means of the screw.

Lord Kelvin made experiments on the relation of the sparking distance to the difference of potential between two parallel plates connected with the quadrants of an electrometer. His experiments and those of other early experimenters agree in suggesting the conclusion that the sparking distance increases at a somewhat greater rate than the difference of potential of the bodies. This, as will be shown presently, agrees with more modern results obtained over longer distances and using much higher electric pressures or differences of potential. Put otherwise, it means that as the electric pressures increase any air gaps across which disruptive discharges may occur must be more than proportionally increased if the discharges are to be prevented. The deduction is of great practical importance.

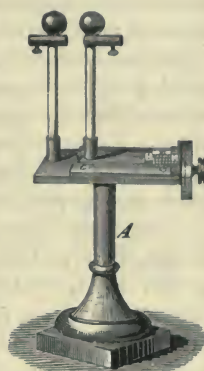

Fig. 116.—Reiss's Spark-micrometer.

To return to the early experimenters: Rijke, who devoted much attention to the subject, found the law of proportionality laid down by Reiss not to be quite correct, and that the sparking distance increases more rapidly than the difference of potential between the sparking bodies. Rijke has given a formula for the calculation of the sparking distance from the potential, and the distances obtained thus, according to the formula, agree with actual observations better than those obtained from Reiss's law, as will be seen from the following table:—

Sparking Distances in Millimetres.	Observed Potential-difference.		Potential-difference calculated by Reiss.		Rijke.	
0·5	...	4·73	...	4·21	...	4·88
1·0	...	9·33	...	8·42	...	8·82
1·5	...	13·00	...	12·63	...	12·73
2·0	...	16·83	...	16·85	...	16·62
2·5	...	20·50	...	21·05	...	20·51
3·0	...	24·33	...	25·27	...	24·39
3·5	...	28·00	...	29·48	...	28·28
4·0	...	31·17	...	33·69	...	32·16

For nearly all the distances given Rijke's calculations are nearer than Reiss's to the observed results, though within the limits of the distances specified Reiss's simpler law of proportionality is near enough for most purposes. The potential-differences are given, most probably, in electrostatic

units, and must therefore be multiplied by 300 to bring them to the more familiarly known volts.

The question of the sparking distance in air at different voltages has assumed much greater importance during recent years owing to the development of methods of electric transmission of energy over long distances. To be economical, such methods, as will be shown fully in the sequel, must employ high voltages, and one of the factors which limits the possible voltage is the dielectric strength of the atmosphere as shown by the sparking distance. Experiments have therefore been made during the last few years by different experimenters to determine the sparking distance under different conditions at pressures up to 100,000 volts, and higher.

Some interesting experiments of this kind were communicated to the Birmingham section of the Institution of Electrical Engineers in 1906 by Mr. E. A. Watson. Two condensers were charged in series with the continuous current from a Wimshurst machine until the potential difference of their outer plates rose sufficiently to break down the insulation of the air in a spark gap, the two sides of which were connected to these plates. The charging current was ingeniously measured by a galvanometer placed between the two condensers, and the potential-difference at which discharge occurred was calculated from the magnitude of this charging current and the time taken to obtain 100 discharges.

The discharges were taken between spheres or balls, and to vary the conditions different sizes of balls were used. Some of the results are given in the following

TABLE OF SPARKING VOLTAGES AT DIFFERENT DISTANCES.

Sparking Distances in Centimetres.	POTENTIAL-DIFFERENCES IN VOLTS.			
	1.35 cm. Balls (53 in.)	1.9 cm. Balls (75 in.)	2.54 cm. Balls (100 in.)	3.2 cm. Balls (126 in.)
1.0	31,100	32,400	34,050	35,000
1.5	38,000	44,200	46,950	47,500
2.0	44,100	53,000	55,600	61,000
2.5	47,500	60,450	64,000	71,000
3.0	50,500	64,500	70,700	80,000
3.5	52,900	68,000	76,600	87,900
4.0	54,500	71,500	81,400	96,400
4.5	56,200	73,600	85,700	102,900
5.0	—	76,900	90,600	107,100
5.5	—	79,200	95,000	112,000
6.0	—	81,400	99,200	—
6.5	—	82,500	103,200	—
7.0	—	85,600	106,600	—
7.5	—	87,400	—	—
8.0	—	89,600	—	—
8.5	—	91,500	—	—
9.0	—	94,200	—	—

The experiments with the two largest balls could not be carried to higher voltages because of disruptive discharges occurring at the condensers, whilst the experiments with the smallest balls (1.35 cm.) could not be extended to greater distances because of brush discharges when the potential-difference was raised to about 60,000 volts. Attention has already been called (*see* page 60) to the effects of curvature on the distribution of electrification on charged bodies and (*see* page 82) to the action of points, that is, bodies of great curvature, in promoting the dissipation of the electric charge. We have in the table on p. 130 some quantitative results on these effects. With the balls of great curvature the experiments on dielectric strength had to be stopped below 60,000 volts because at higher voltages the charge leaked away in the manner previously described before the air broke down. With balls of less curvature, however, the voltage was pushed up to 112,000 volts before quite different causes stopped the experiments.

The effects of curvature in concentrating the charge and thus starting the discharge are also seen in the higher voltages required for

the same distance by the larger balls as compared with the smaller. Thus, at 10 cm. distance the largest balls require nearly 4,000 volts more than the smallest, whilst at 4.5 cms. the difference is as much as 46,700 volts. the ratio being nearly 2 to 1.

The results given in the table, together with some others, are graphically depicted in the curves in Fig. 117, in which the sparking distances are plotted horizontally and the corresponding sparking voltages vertically. Curves I., III., IV., and V. give the results in the table, whilst Curve Ia., which is very nearly a production of Curve I., is obtained by increasing the size of the  $-ve$  electrode to 3.2 cms., the  $+ve$  electrode remaining at 1.35 cms. By this change the sparking distance could be increased to 9 cms. at a voltage of about 73,000 volts.

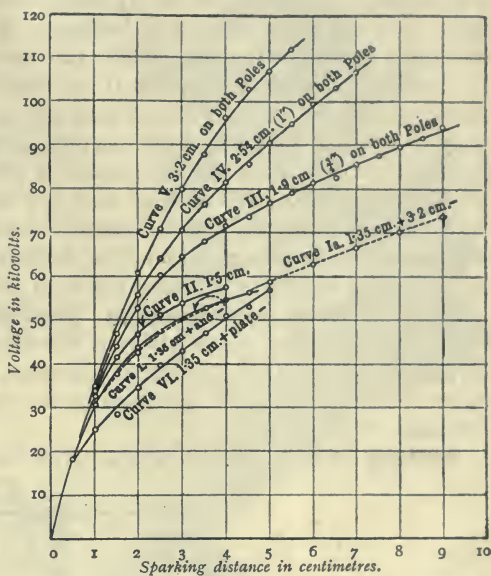

Fig. 117.—Spark-length Voltages for different Electrodes.



Experiment further showed that the curvature of the  $-^{\text{ve}}$  electrode was much more important than that of the  $+^{\text{ve}}$  electrode. The increase of sparking distance obtained in Curve Ia, could not be obtained if the polarities were reversed and the larger ball made positive. Hence the conclusion reached by the author that "within moderate limits the sparking voltage of any gap is determined by the size of the smallest electrode." This is the first experimental instance to which we have as yet referred tending to show that the difference between  $+^{\text{ve}}$  and  $-^{\text{ve}}$  electrification is something more than can be expressed by a mere difference of algebraic sign; later on other differences, leading to a more intimate knowledge of the nature of electricity itself, will be dealt with.

The above results are for air at the ordinary pressures, which during these experiments varied between 29.4 and 30 inches of mercury. As the density of the air is increased the sparking distance is lessened, but becomes greater when the atmospheric pressure is diminished. What takes place at very low pressures will be dealt with in a subsequent chapter. Not only the density, but also the chemical composition of the medium, influences the sparking distance. Faraday found the distances considerably less in chlorine gas, but twice as long in hydrogen gas as in air.

**Other Effects accompanying Discharge.**—The spark referred to above is a luminous effect which is accompanied by the generation of heat. There are also mechanical, chemical, magnetic, and physiological effects either in the spark gap itself or the conductors through which the discharge takes place.

**Heating Effects of Discharge.**—The heating effect of the electrical

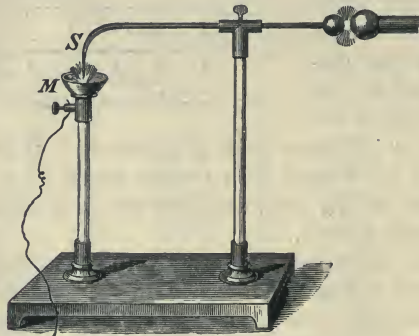

Fig. 118.—Heating Effect of Discharge.

spark can be shown by means of the apparatus, Fig. 118. The brass basin *M* rests on a glass pillar, and into *M* dips the point *S*, but without touching it. Into the basin, which is connected with the earth, inflammable sub-

stances, such as ether, alcohol, etc., are brought. The knob of a charged Leyden jar is brought near the ball at the other end of the rod *s*, when a spark will pass from *s* and ignite the substance contained by the basin.

To ignite substances such as gunpowder, Henley's universal discharger, shown in Fig. 114, is made use of, and the heating effect of the electric spark may be further shown by allowing it to pass through combustible gases.

Reiss invented an instrument, shown in Fig. 119, to measure the heat

caused by electrical discharges. The glass globe *k*, whose diameter is 3.6 inches, contains a platinum spiral terminating in the screws *s s*. A tube with a small but uniform bore, terminating in the vessel *g*, runs from the lower portion of the globe, as shown in the figure. *B* and *G* are of wood, and the former can be raised or lowered at the end by the metal prop adjusted by means of the screw *b*. Thick wires connect the platinum spiral with the binding screws *D D*, which are supported on glass rods. At *o* the globe has a well-fitting glass stopper by which the atmospheric pressure can be regulated. When readings are taken, the glass tube is first filled with some fluid; the stopper *o* is replaced, and the platinum wire inserted in the circuit by means

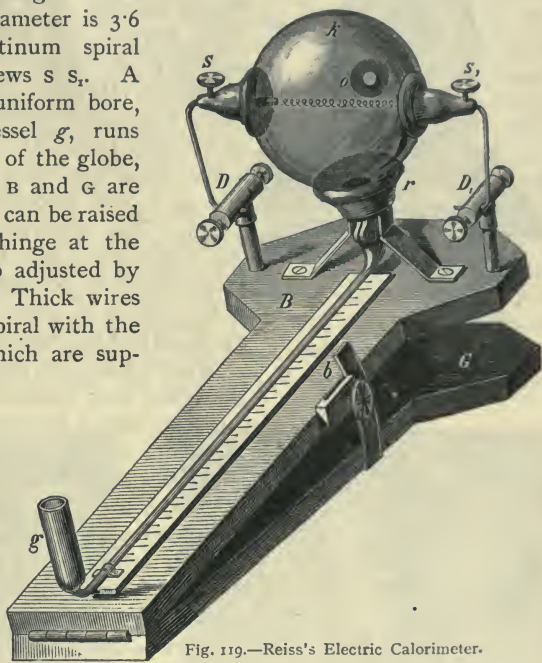

Fig. 119.—Reiss's Electric Calorimeter.

of *D D*. When the discharge has taken place the platinum wire becomes heated, and causes the air in the globe to expand, pushing the liquid in the tube towards *g*. By means of the depression in this tube we are able to determine the heating effects of an electrical discharge of a battery.

Careful quantitative experiments made by Reiss showed that the heat generated in the platinum wire is proportional to the *square* of the quantity of electricity discharged through it, a very important result, and in accordance with equation (c<sub>3</sub>), page 124.

**Mechanical Effects.**—To the simplest mechanical effects belongs the electrical wheel or windmill already referred to (page 83), the motion of

which we have already discussed. When we place the electrical wheel under the receiver of an air-pump, and then charge it after the air has been exhausted, we find that it rotates far more slowly than before. The phenomena of attraction and repulsion have been made use of for electrical toys, as, for instance, the electrical butterfly, electrical hammer, etc., etc., the principle of which will be understood from the following description of one, namely, the electric hail.

Several cork and pith balls are placed on a metal plate which is connected with the earth. A bell-jar, through the neck of which there passes a brass rod terminated by balls, covers the whole (Fig. 120). The inner ball becomes electrified when the outer is charged, and attracts the cork balls, electrifies them, and then repels them. The electrified cork balls fall upon the metal plate, lose their electricity, and are again attracted by the brass ball. The cork balls continue to jump about until the charge in the brass ball has nearly spent itself.

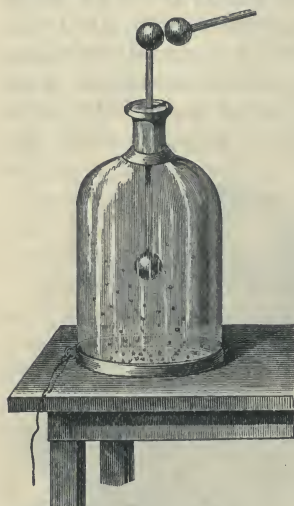

Fig. 120.—The Electric Hail.

Fuchs observed that when water-drops are electrified they coalesce and become larger, and the relationship between the size of the rain-drops and the electrical condition of the atmosphere has attracted the attention of physicists.

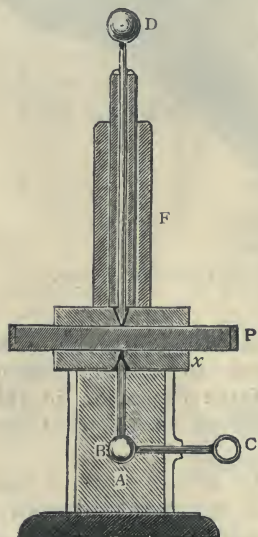

Fig. 121.—The Perforation of Glass.

In the historical introduction we mentioned an experiment that served to support Du Fay and Symmer's theory: we mean the perforation of a stout piece of paper by means of the electrical spark. The turning up of the edges on both sides was accounted for by stating that an electrical discharge was the result of two currents flowing in opposite directions to each other. Reiss, however, holds that the experiment only proves that the mechanical effects produced by the current spread uniformly in all directions, and the fibres of the paper give way in that direction where they find least resistance. If the electrical discharge is sufficiently powerful, it will perforate glass plates of considerable thickness. An arrangement which may be used for this purpose is shown in Fig. 121. A short glass tube *A* filled with shellac is closed at the top with a thick plate of glass *x* having a conical

with shellac is closed at the top with a thick plate of glass *x* having a conical



hole in the middle. Into this hole projects a wire, which, passing down as shown, ends in the ball *B*, from which a wire passes through the tube to the external ring *c*. The plate *P* to be pierced is placed on *x*, and on top of it is put the plate *y* similar to *x*, and with the conical holes exactly in line. On this rests a narrower and longer glass tube *F*, likewise filled with shellac, through which passes a wire terminating in the ball *D*. Care ought to be taken that the glass plate to be pierced is dry and clean.

**Electric Dust Figures.**—Lichtenberg's figures are another illustration of the effects of electrical discharges. These figures are obtained in the following manner: An iron point connected with the inner coating of a Leyden jar or the prime conductor of an electric machine is held over a smooth cake of resin. Through this point the resin cake receives its charge. The metal point is withdrawn, and a fine powder is dusted through a piece of muslin over the cake. The dust then arranges itself in distinct figures. The dust mixture usually consists of red lead and sulphur, or vermilion and lycopodium powder, and is shaken out from a muslin bag. The particles rub against each other and against the muslin and become electrified, the sulphur negatively and the red lead positively. The former are attracted by the positively electrified parts of the resin cake, the latter by the negative. The positively electrified places will appear yellow, and the negatively electrified places red. But the difference of form is of more importance than this difference of colour. Fig. 122 shows



Fig. 122.—Positive Dust Figure.



Fig. 123.—Negative Dust Figure.

the characteristic figure for a positive charge; Fig. 123 the same for a negative charge. If the resin cake has a mixed charge—that is, positive and negative—we obtain a mixed figure. Fig. 124 represents such a figure. We observe a red disc in the centre, corresponding to the negative electrification, surrounded by rays of yellow, corresponding to the

positive electrification. In Fig. 125 is shown the effect of a discharge between the  $+$  and  $-$  poles of a machine; it strikingly illustrates the difference between the ramifications proceeding from the  $+$  pole and the sheave- or disc-like appearance surrounding the  $-$  pole. The last two figures are most easily produced by a Ruhmkorff coil.

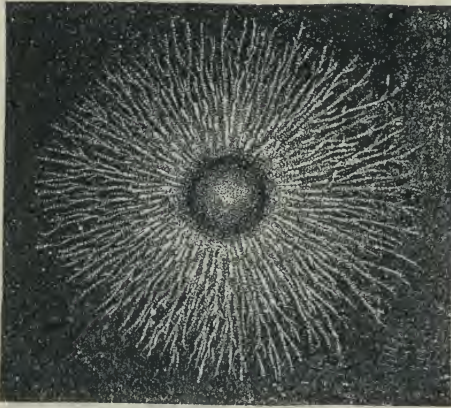

Fig. 124.—Mixed Dust Figure.

The investigation of Lichtenberg's figures has been continued by Bezold, Reitlinger, Reiss, Wächter, and others. Wächter, especially, made experiments under many conditions, and he succeeded in obtaining positive figures which had the appearance of negative ones; this, however, only happened when the point through which the charge was directed was made of a non-conducting substance, having

its surface free from dust; but he never obtained negative figures resembling positive ones. From these experiments Reitlinger and Wächter concluded

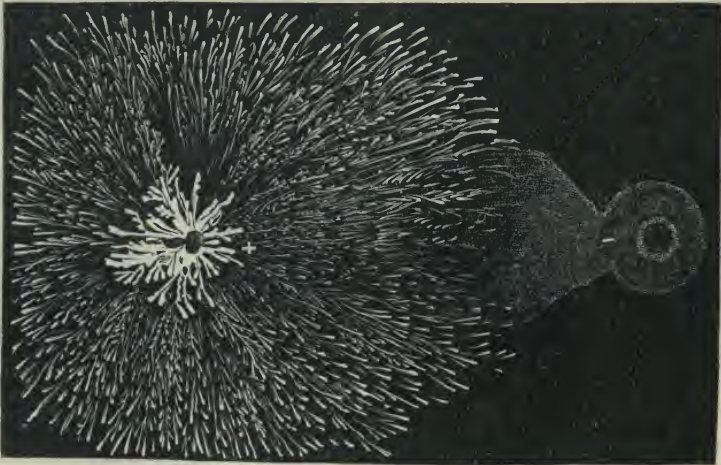

Fig. 125.—Dust Figure Showing Discharge from Both Poles.

that for the production of positive figures the carriers of electricity must be rigid particles, which are hurled from the point towards the surface on



which they slide, and to which they give up their electricity. When a spark passes between metals, little particles are torn off the positive metal, as has been already mentioned. Now it is these particles that cause the ramification in the positive figures, for if a non-conductor be used, such as a piece of wood, the tearing off of the particles does not take place, and the figure is simply a round disc. Electrification of the resin plate in this case is obtained through the agency of particles of air, which electrify the plate uniformly in all directions. If, however, the surface of the bad conductor be covered with dust, this dust will be hurled away by a positive discharge, and the positive figure will then show the ramifications in spite of a non-conducting substance being used. Wherever negative electricity is imparted to the resin surface, traces of *disc-shaped* distribution are left behind; whilst positive electricity produces figures which may appear, according to circumstances, in radial lines, or in circular discs and rings. To produce a negative figure with even the slightest trace of lines has been found impossible.

For the production of Lichtenberg's figures we may not only use resin plates, but also glass, ebonite, wax, etc. The powder, too, may be changed for others, provided one of the ingredients becomes positively electrified, and the other negatively electrified, when rubbed together. Such powders have been termed *electroscopic*.

#### Physiological and Chemical Effects of Electrical Discharges.—

When we bring a finger near to a charged conductor we feel an unpleasant sensation, and if the spark is powerful serious injuries may be received. The spark of a battery of Leyden jars is capable of killing large animals.

When the discharge of a battery is conducted through chemical compounds, they may be decomposed. For instance, if from the negative and positive conductors of an electrical machine wires are dipped into a solution of sulphate of copper, and the machine is worked for some time, we shall find on the wire of the negative conductor metallic copper deposited, although the action is a very slow one. The peculiar odour in the air about an acting electric machine is also due to the chemical effects of electrical discharges; the molecules of oxygen are decomposed and rearranged in a modification known under the name of ozone. The production of ozone electrically is now regularly carried on commercially, and special pieces of apparatus known as *ozonizers* have been devised to produce the gas economically and in large quantities.

**Magnetic Effects.**—Magnetic effects of electrical discharges show themselves in two different ways. A magnetic needle free to move is influenced when brought near a circuit through which discharges take place. When electrical discharges are conducted through a wire spiral, in the centre of which there is a steel needle, this needle will become a permanent magnet.



**Luminous Effects.**—In addition to the luminous sparks referred to above, the electric charge gives rise, under varying circumstances, to a great number of beautiful luminous and other effects. Some of these, in the form of X-rays or Röntgen rays, have become very important during the last few years. There are, however, methods of producing electric discharges other than those due to electrostatic machines and it will be more convenient to postpone the consideration of these somewhat important effects until after the description of the electro-magnetic methods of obtaining the discharges.

**The Return Shock.**—Many electrical effects of discharges are to be accounted for by the violent disturbances set up in the medium. The return shock sometimes felt by persons standing near a conductor which is being discharged is so caused and may be explained in this manner. Two conductors are placed near to the points between which the discharge is to take place; the one farthest from the circuit being connected with the earth. Whilst the discharge is taking place in the circuit, the two conductors will be influenced by it. The two conductors being differently situated with respect to the charged bodies are differently influenced by the electric induction from them. Not only is the dielectric between the charged bodies in a state of strain which is finally increased up to the breaking point, but the remainder of the dielectric in the neighbourhood, including that surrounding the two conductors, is also in a state of strain, and one of these being connected to earth becomes charged. Now when the two charged bodies are discharged the cause of this state of strain is suddenly removed, and the dielectric and the neighbouring conductors return to their natural condition. This, however, necessitates a very rapid re-arrangement of electrical strains and distributions existing a moment before in the medium and on the conductors, and in this re-arrangement violent momentary currents may occur in the conductors, giving rise to what is known as the return shock.

**Atmospheric Electricity.**—The upper layers of air are more or less electrified, so as to have a potential differing from that of the earth, but how their electrical condition has been produced is not at present known. Condensation of water-vapour is known to produce electrical separation, and this condensation is greatly assisted by the presence of dust particles which act as nuclei. Recently it has been suggested that electrification may be due to the presence of the  $+$  and  $-$  ions in the air, and to the fact that the  $-$  ions more easily form nuclei than the  $+$  ones; these, being carried down first, the  $+$  ions are left behind with their charges to electrify the air. It is found that there are greater differences of electrical condition at different elevations under a clouded sky than with a clear sky, and it is always clouded when there is a display of lightning. Lamont considers the atmospheric electricity to be a consequence of the earth's electricity.

Close to the earth the air has little or no charge ; the farther from the earth the greater the amount of electrification in the air.

**Difference of Potential in the Air.**—Employing the terms we have now adopted to indicate a difference of electrical conditions, we should say that many experiments prove that there is a difference of potential between the earth and points in the air above. In fine weather the potential is higher the higher we go, increasing usually at the rate of twenty to forty

volts for each foot, and balloon observations appear to show that it continues to increase up to a height of about four miles, after which it remains constant. It changes, however, very rapidly in broken, windy, and rainy weather, and is even at times reversed, becoming for a time negative as regards the earth. The plans adopted to test the potential at any point usually consist in placing an insulated conductor at that point, and allowing for the discharge of free electricity from it, its electrical condition being afterwards tested by an electroscope or electrometer. This discharge takes place when material particles are made to leave the conductor. Volta used a small flame at the end of an exploring rod. Lord Kelvin used an insulated water-can, from which water was allowed to drip, or an exploring rod with smouldering touch-paper at the end. He has also employed with success a portable electrometer, on the same general principle as the quadrant or divided ring electrometer.

Peltier used an insulated pith-ball electrometer with a metal dome, and means of connecting it for an instant with the earth.

**Lightning.**—Lightning is due to the equalisation of potential in the clouds, where the electrical spark appears as lightning and the sound it produces as thunder. Lightning chooses the easiest path for its passage. Three forms of lightning are usually recognised : fork lightning, sheet lightning, and ball lightning. Sheet lightning may be regarded as brush-like discharges from cloud to cloud ; it is not necessary that one of the clouds should have positive and the other negative electricity. As we can draw sparks from an electrified body by bringing near it an un electrified body, so an electrified cloud can lose its electricity to a non-electrified cloud. Fork lightning may be compared to the spark with ramifications, and the

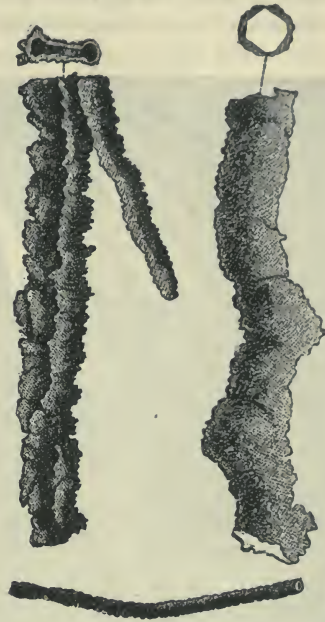

Fig. 126.—Lightning Tubes (fulgurite).



same explanation may be given of it. The quantity of electricity in a cloud depends on its capacity and potential; if the capacity diminishes while the quantity remains the same, the potential rises. Now the capacity of a sphere such as a rain or water drop is measured by its radius, but if two equal drops of water coalesce to form a single drop the radius of the single drop will only be about 26 per cent. greater than that of either of the smaller drops. The capacity in this case therefore falls somewhat in the ratio of 2 for the separate drops to 1.26 for the single large drop. The difference of potential, therefore, between two masses of cloud, or between



Fig. 127.—The Aurora Borealis.

one mass of cloud and the earth, may become so great by the coalescing of drops and consequent reduction of capacity, that the intervening air gives way under the strain, and a flash of lightning is the result. When lightning is directed towards our earth, it strikes the highest points first, such as the tops of towers, trees, etc., and then takes that path to earth which offers least resistance to its passage. If lightning has to pass through dry sand, it fuses it, and produces what is known as lightning tubes or "fulgurite," some forms of which are shown in Fig. 126.

Ball lightning, a phenomenon not very frequently met with, consists of balls of fire visible for about ten seconds, and then bursting with a loud explosion. Lightning without thunder may be the reflection of



a far distant thunderstorm, or the quiet flowing out of electricity from the clouds. The St. Elmo's fire shows itself in brush-like little flames, appearing on the sharp edges or points of different bodies when the air is rich in electricity. Sometimes a peculiar noise which is characteristic of the flow of electricity from points is heard when the brushes are seen. Lightning often covers a distance of more than a mile; owing to the rapidity with which the flash travels through the air we see the whole distance illuminated. The time which elapses between the flash of lightning and the accompanying thunder serves often to determine approximately the distance of a thunderstorm. Light from such



Fig. 128.—The Aurora Borealis.

a distance reaches us almost immediately; sound travels about 1,100 feet per second in air at the ordinary temperature. The thunderstorm, therefore, will be at a distance of 1,100 feet  $\times$  by the number of seconds that have elapsed between the flash and the report.

**The Aurora Borealis.**—This phenomenon is seen in the polar regions every night, in somewhat lower latitudes seldom, and in the regions of the equator never. In the intermediate latitudes hardly more than a reddening of the evening sky is seen; but in the polar regions it is one of the most brilliant phenomena, as will be apparent on inspecting Figs. 127 and 128. The latter figure represents the aurora as observed once by Lemstrom, who has been able to produce experimentally some of the effects seen in nature.

Although the nature of the aurora borealis as yet is little understood, it seems clear that magnetic storms, or disturbances of the earth's magnetism, are due to the same cause, for they always occur together. There are many points of similarity between a discharge of electricity through tubes of rarefied air and the auroral phenomenon. Franklin explained the aurora as an electric discharge in the rarefied atmosphere of the upper regions, between the cold air of the polar regions and the warmer air from the tropics. The rarefied air is nearer the earth at the poles than the equator, in consequence of the earth's motion of rotation, and the earth being negatively electrified, negative electricity will flow from this point, directed against the positively electrified upper layers of rarefied air.

## CHAPTER III.

## THE ELECTRIC CURRENT.

## I.—INTRODUCTORY.

WHEN the charged coatings of a Leyden jar or condenser are connected by a conductor all trace of electrification speedily disappears, and the Leyden jar or condenser is discharged. If the resistance of the conductor used be not sufficiently low to cause the electrical oscillations referred to on page 98, we find (*see* p. 132) that this conductor, at the moment of discharge, exhibits certain thermal, chemical, and magnetic effects. Assuming the phenomenon of electrification to be due to the presence of an excess of electricity, regarded as a fluid, on the positively charged surface of the condenser, there being an equivalent deficiency on the negatively charged surface, then it is natural to assume further that the process of discharge consists of the flow of the electric fluid from the positively charged to the negatively charged surface through the connecting conductor. Such a flow, whilst it lasted, would constitute a true current of electricity, and would be rightly called an "electric current."

The justification for using the phrase, however, depends more largely upon the suppositions made regarding the nature of electrification than on direct experiment bearing on the point, for we know that the medium surrounding the conductor plays a very active part in the phenomena connected with the discharge, and that these are far from being confined to the conductor. But the term "electric current," and the other terms consequent upon its use, are very convenient as tending to conciseness in the description of the phenomena and in many necessary calculations. They also find some further justification in the electronic theory of electricity, which has recently been advocated, and to which allusion will be made later. But whether theoretically justifiable or not, these expressions would still be used, being, in fact, examples of the persistence of terms (*e.g.* "latent heat") founded upon obsolete and sometimes exploded theories to be found in many branches of physics. Moreover, the so-called electric current in the laws which govern its flow offers a fairly close analogy, in many respects, to a current of water or other fluid, especially an incompressible fluid, passing through a closed pipe.

This analogy is very useful in inculcating clear and precise quantitative ideas regarding the elementary laws of current flow, but great care has



to be exercised that it is not pressed too far and that the very similar terms employed in the two classes of phenomena are not assumed to connote identical instead of only analogous properties. For example, the word "resistance" is used both electrically and hydraulically, but with a widely different physical meaning in the two cases.

The term "electric current," in the present state of our knowledge, should be regarded as denoting the existence of a state of things in which certain definite experimental effects are produced, for some of which there certainly is no analogy exhibited in ordinary hydraulic currents. The most important of these effects, especially if the state be steady, are the thermal, chemical, and magnetic effects to which we have already alluded, and it is rather to these effects than to any imaginary flow of a supposititious current in the conductor that the mind of the reader should be directed.

With this preliminary caution, which should never be lost sight of, we shall freely use familiar words and expressions connected with the flow of water in pipes, and thus avoid roundabout and cumbrous phrases which, though, perhaps, more nearly in accord with our present knowledge of the facts, would not tend to clearness or conciseness. We shall also make free use of the hydraulic analogy without further comment except when important limitations may have to be pointed out.

The three most important effects of which we have been speaking may be conveniently recapitulated here in a somewhat fuller manner than they have yet been referred to. They are as follows:—

1. The *Thermal* effect.—The conductor along which the current flows becomes heated. The rise of temperature may be small or great according to circumstances, but some heat is always produced.
2. The *Magnetic* effect.—The space both outside and inside the substance of the conductor, but more especially the former, becomes a "magnetic field" (*see* p. 27), in which delicately pivoted or suspended magnetic needles will take up definite positions and magnetic materials will become magnetised.
3. The *Chemical* effect.—If the conductor be a liquid which is a chemical compound of a certain class called *electrolytes*, the liquid will be decomposed at the places where the current enters and leaves it.

**Conditions for the Production of a Current.**—The particular experiment referred to above, *i.e.* the discharge of a condenser or Leyden jar, is interesting historically because from it, or from practically similar cases, the term "electric current" took its rise. But in this instance the effects which we now associate with the existence of a current are transitory and, with ordinary apparatus, small and insignificant. There are, however, methods by which these effects can be produced on a much larger scale

and for considerable periods of time, and it is such methods of production that are now to be examined.

To produce a steady flow of water in a pipe two conditions are necessary. There must first be available a hydraulic pressure, or, as it is technically called, a "head" of water produced by pumps or a difference of level or otherwise. Such a pressure is produced in an ordinary dwelling house, supplied from a cistern in the top story, by the difference in level between the surface of the water in the cistern and the tap from which the water is being drawn. But, in addition to the pressure, there must also be a suitable path or channel provided for the water to flow through, or there will be no flow, however great the "head," until something breaks down under the strain. In the case just cited, although there is full pressure in the water in the pipe, there is no current of water as long as the tap remains closed. The opening of the tap completes the necessary path (the greater part of which was already in existence) and the water flows.

For the production of a steady electric current two very similar conditions are necessary. We must first of all have a steadily maintained electric pressure, known under different aspects as an "electromotive force," a "potential-difference," or a "voltage." But this alone is not sufficient. We must have, in addition, a suitable conducting path formed from certain materials which experiment has shown to have the necessary properties. Any break in this path occupied by unsuitable material acts like the closed tap in the analogous case above mentioned, and it is only when all such breaks have been properly bridged by suitable material, *i.e.* by conductors, that the effects which denote the flow of the current will begin to be manifested. Our first concern will therefore be to examine how these two conditions can be satisfied in practice, and we shall take them in the order named.

There are several methods by which an electromotive force or an electric potential-difference can be produced. Some of these have already been considered in the preceding section, but the methods there dealt with are not adapted to the production of electric currents on a large scale. The electric pressures so produced are also very high, but the quantity of electricity set in motion is, in most cases, very minute; the currents, therefore, are small, and the current effects, as a rule, insignificant. In consequence, however, of the high pressures we have brilliant effects due to the breaking down of the insulating or non-conducting materials. The cases are analogous to the existence of a very high hydraulic pressure in a very narrow pipe containing only a small quantity of water. No large current is possible, because there is not enough water. Also if the pipe be burst by the excessive pressure the current produced is but small and transitory, because of the rapid disappearance of the pressure, however high. With a much lower pressure, continually renewed, and

a bigger pipe with a plentiful water supply, much larger and more lasting currents are possible.

There are three chief electrical methods by which the necessary pressures can be produced and maintained notwithstanding the tendency of actual currents to lower the pressure producing them. One of these, the chemical method, which was the first to be evolved, is intimately associated with the chemical effect of the current. The other two, the thermal and magnetic methods, especially the former, are not so closely related to the thermal and magnetic effects, though in the last-named case the phenomena are sufficiently interdependent to make it more convenient to postpone the consideration of this method of producing an electromotive force until after the magnetic effects have been expounded. We shall therefore, for the present, be content to describe only the chemical and thermal methods. Later on, when the laws and effects of the current have been more fully set forth, we shall deal with the magnetic method, which, in the developments of the last thirty years, has taken a predominant position as a method for the economical production of the widely used and large currents, which are now so marked a feature in electrical science, and especially in those branches which are more particularly devoted to the service of man.

## II.—THE CHEMICAL PRODUCTION OF THE ELECTRIC CURRENT.

In the historical introduction mention has been made of the almost contemporaneous experiments of Galvani and Volta, which form chronologically the starting point of the production of steady electric currents. The experiments of these two *savants* are closely related, and both lead directly to the same method of producing a current.

Galvani's fundamental experiment, first made in 1790, consisted in attaching one end of a metallic conductor to the crural muscles and the other end to the lumbar nerves of a freshly killed frog. Violent muscular contractions resulted which he considered to be due to a kind of Leyden jar discharge from the muscles, the nerves acting as conductors. Discharges from a small Leyden jar through the limb were found to produce similar contractions.

Volta, repeating and extending Galvani's experiments, showed, in 1793, that the contractions could be produced "by metallic touchings of two parts of a nerve only, or of two muscles, or even of different parts of one muscle alone," but that in these cases it was absolutely necessary that the conducting metallic arc should consist of two *different metals*. With the theory of Contact Force propounded by Volta to explain his experiments and with the rival theory of Chemical Action we shall deal later; we are now concerned more with Volta's further work, which resulted in the invention of the Voltaic Pile.



From the experiment with two different metals and the single muscle Volta proceeded to dispense altogether with the materials obtained from the bodies of animals. He found first that the muscular effects were much increased by increasing the number of metallic junctions in the conducting arc, provided these bimetallic pieces were connected by liquid conductors. In these investigations he invented the "Crown of Cups" shown in Fig. 129, which is reproduced from one of his papers.



Fig. 129.—Volta's "Crown of Cups."

The metallic arcs *c a z* each consisted of two metals, the section *c a* being of copper and the section *a z* of zinc. They were placed, as shown, in the glass vessels, which contained salt water and ordinary water or lye. Into each vessel, except the two end ones, the copper end of one arc and the zinc end of the next were introduced, the series, however long, ending with copper dipping into the terminal vessel at one end and zinc into that at the other. The arrangement is almost exactly that of a modern one-fluid primary battery, and Volta found, on carrying wires from the terminal vessels to his test muscle, that the muscular contractions became more violent as the number of "cups" in the "crown" was increased.

**The Voltaic Pile.**—The arrangement was made much more compact in 1800 by abolishing the glass vessels and substituting for them pieces of textile material moistened with the necessary liquid. This led to a form of battery which, on account of its shape, Volta called a "pile," a name which is still used in France for the Voltaic battery. An early form of this "Voltaic Pile" is shown in Fig. 130, which again is copied from a paper by Volta. Its metallic parts consist of discs *c* of copper and *z* of zinc. These are built up in a regular sequence with discs of cardboard moistened with acidulated water. In the figure the bottom disc is of copper, on which is placed a disc of zinc, followed by a moistened card and another disc of copper. This sequence was repeated in the building up of the pile and always in the same order, namely, zinc, moistened card, copper, the zinc always being in contact with the lower side of the card and the copper with the upper. The number of "elements" consisting of zinc, card, and



Fig. 130.—Volta's First "Pile."

copper which could be introduced into the pile was only limited by mechanical considerations, and to increase the stability of the arrangement the four supporting rods *m* of non-conducting material were placed at the side. The lowest copper plate was connected by a strip of copper to a vessel of acidulated water for convenience in making connections to external apparatus, and when the pile was completed the uppermost disc was connected to a similar vessel.

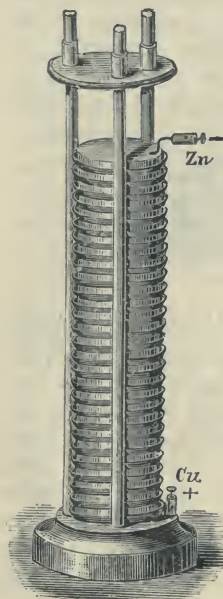

Fig. 131.—Voltaic Pile.

A modern form of the Voltaic Pile is shown in Fig. 131. The changes from the early form are but slight. The four supported columns have been reduced to three, and the terminal vessels of acidulated water have been replaced by binding screws attached to wires soldered to the lowermost and uppermost discs respectively. The difference of potentials between these binding screws Cu. and Zn. is found to depend directly on the number of "elements" in the pile, and on examination with a sensitive electro-scope it will be found that the binding screw Cu. at the copper end is at a higher potential than the binding screw Zn. at the zinc end. Cu. is therefore positively electrified as compared with Zn., which is negatively electrified. On connecting these by a conducting wire a current should flow from Cu. to Zn. as in the case of the discharge of the plates of a Leyden jar.

There is, however, one fundamental difference between the two experiments. With the Leyden jar the discharge is transitory and

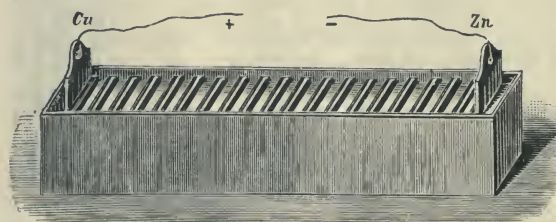

Fig. 132.—Cruikshank's Battery.

practically instantaneous, all sign of electrification disappearing immediately. With the voltaic pile the current continues to flow and produce its characteristic effects for a long period of time, the pile causing a renewal

of the positive and negative electrifications of Cu. and Zn. as rapidly as this electrification is discharged by the conductor. If the conductor be removed, the current, of course, ceases, but an examination of the Cu. and Zn. terminals will show that these bodies are still electrified.

The voltaic pile, or "battery," as we call it in England, soon underwent many alterations; Cruikshank, for instance, gave it the form shown in Fig. 132,

and Wollaston the form shown in Fig. 132. Here we have a return to Volta's earlier form of the "crown of cups" in the fact that all the couples are contained in separate cells *a d* of glass or porcelain, which hold the exciting fluid. In each cell of Fig. 133 the zinc plates *z z* are kept centrally adjusted by wooden slips between the halves

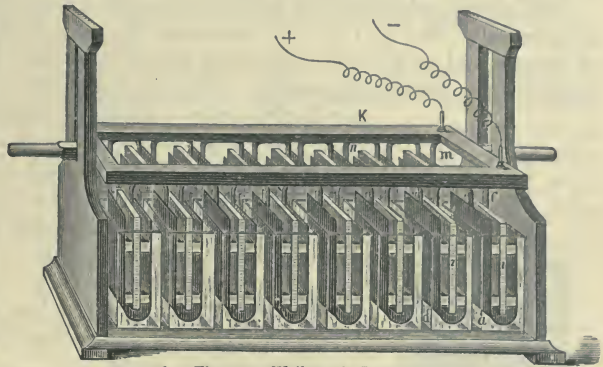

Fig. 133.—Wollaston's Battery.

of a doubled copper plate bent round under them; and the whole set of plates, connected by strips of copper *m*, being attached to the wooden frame *K*, can at pleasure be lifted out of the fluid, and the action thus stopped without emptying the cells. All these points, modified according to the construction, are retained in many of the batteries used at the present day. To secure a large surface to both plates, Hare placed large copper and zinc sheets together, separating them by means of pieces of wood and rolling them into a cylindrical shape. His apparatus is known as Hare's deflagrator, from the striking heating effects it can produce in low resistance circuits. It is represented in Fig. 134, the lower part of the figure being a cross-section intended to show how the copper and zinc sheets are rolled into a spiral and the positions of the wooden insulators. The feature of this method of construction is that it gives a cell with a very low internal resistance, the advantage of which will be explained presently. The same method, with the same object in view, was adopted by Faure in 1881 for the early forms of the Faure Secondary Cell.

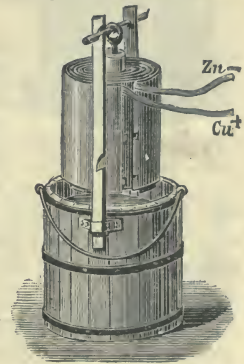

Fig. 134.—Hare's Deflagrator.

the Faure Secondary Cell.



## III.—THEORIES OF THE VOLTAIC CELL.

The simple voltaic cell, of which those above described are modifications, is represented in Fig. 135. It consists, as we have already seen, of a plate of copper and a plate of zinc, each partially immersed in the acidulated water in the containing vessel.

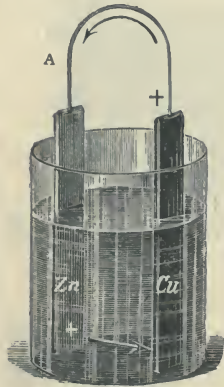

Fig. 135.—Typical Voltaic Cell.

When these plates are connected by a conducting wire outside the liquid, a current flows from the copper plate to the zinc plate through this conductor. Several points here require attention.

In the first place, the so-called *direction of the current* depends upon our theoretical assumptions. The assertion, therefore, that it flows in the wire A from copper to zinc is to be regarded purely as a convention, which, however, has the great advantage of giving precision to several terms which would otherwise remain vague.

Next, if the conducting wire be removed and the electrical condition of the two metals examined, we find that the zinc end *not* immersed is negatively electrified, and the dry copper end positively electrified, and at a higher potential than the zinc end. Hence, when the circuit is completed a current of electricity flows from the copper to the zinc, and the above-mentioned phenomena are manifested. From these facts we conclude that electricity must be in motion not only through the connecting wire, but also between the immersed ends of the metals in the liquid. For the current differs from that produced by the discharge of two oppositely electrified conductors, in that it is not momentary but continuous. In other words, electricity continues to flow in an apparently inexhaustible stream from the copper to the zinc through the wire. But there is no evidence of its accumulation on the zinc, therefore it must return to the copper by the only other conducting path available, namely, the liquid. Hence, when the plates are joined by a wire it follows that positive electricity flows from the immersed zinc end through the fluid to the copper in the fluid. Positive electricity flows, then, *inside* the cell from zinc to copper, *outside* it from copper to zinc.

**Production of Potential-Difference.**—Before the partially immersed plates are connected by a wire, on being tested by an electrometer they are found to have a difference of potential, the free end of the copper having a higher potential than the free end of the zinc. Pushing the investigation still further, we find that when zinc alone, or copper alone, is immersed in the dilute acid, there is a difference of potential in each case between the metal and the acid, the metal being negatively

electrified and the acid positively. These differences of potential are not equal in the two cases, and the final result obtained in the voltaic cell on open circuit (that is, when no outside conducting wire is used and no current is flowing) is the *difference* between the two values due to zinc and copper separately immersed.

Generalising still further, we find that when any solid is immersed in a liquid that can act chemically upon it, there is a difference of electric potential between the liquid and the solid, even though the amount of chemical action actually taking place may be so slight as almost to defy detection and measurement. Also the actual potential-difference may be approximately calculated when the energy values of the chemical action are known. In fact, this electric potential-difference is probably a good, as it is certainly a convenient, method of measuring quantitatively the physical entity often referred to by chemists, and usually in the vaguest manner, as *chemical affinity*. Since the values change as a rule with each change of metal or of liquid, we see that to obtain a voltaic cell, all we have to do is to *immerse two different conductors in a liquid that can act chemically upon at least one of them*.

**Energy Transformations.**—Before giving any of the actual values of the potential-differences, some other experimental facts should be noticed. When a voltaic cell is sending a current through a conductor heat is generated in the conductor. Now heat is one of the forms of energy, and the establishment on a firm basis of the theory of the *conservation of energy* was one of the triumphs of the nineteenth century. This theory asserts that energy can be neither created nor destroyed, though it can take many forms, and that whenever a quantity of energy is generated anywhere an exactly equivalent quantity, probably in some other form, must disappear either there or elsewhere. Whence, then, comes the energy which furnishes the heat generated in the conductor? The answer is that it is furnished by the dissolution of the zinc in the acid, for it will be found that as the current flows zinc is dissolved. One of the forms of energy is known as the energy of chemical separation, and is due to the separation of bodies which are capable of combining with one another. The most familiar example is that of coal and the oxygen of the air. Uncombined these bodies represent a potential store of energy, which is transformed when they combine into heat-energy, which can either be wasted or may be utilised to drive our steam or gas engines. Similarly with zinc and sulphuric acid: uncombined they possess a potential store of energy which, when they are allowed to combine, is set free and may appear either as heat in the vessel in which combination occurs or as electrical energy in a conducting circuit. In the latter case it may be wasted as heat in the conductors, or may be utilised by methods which will appear in the sequel. Joule, in 1845, showed that for every unit of heat appearing in the external wire or of work done in the external

circuit an exactly equivalent quantity of energy disappeared from the cell.

We have already seen that the two factors of energy in a charged condenser are the charge ( $Q$ ) and the potential-difference ( $V$ ) of the plates. Similarly in a voltaic circuit these factors are the quantity ( $Q$ ) of electricity set in motion and the electromotive force ( $E$ ) of the cell. If we allow the current to continue just long enough for a unit quantity of electricity to pass any point and no longer, the energy spent in the circuit will be numerically equal to the E. M. F. Since we know exactly the quantity of zinc dissolved during the passage of unit-quantity of electricity (*see* page 196), we are therefore able to calculate the E. M. F. in the circuit.

The results of the calculation are given in the following tables, in which the first column contains the name of the metal referred to. The second column gives the weight of this metal, which entering into combination evolves the heat set down in the third column. The reasons for selecting these particular weights are that they are the *relative* weights which enter into the chemical changes with which we are dealing. The numbers in the third column are the amounts of energy given out by these chemical changes when that energy is all allowed to appear as heat, and it must be borne in mind that these figures are the results of purely *thermal* and not of electrical experiments. The numbers in the fourth column are the electric pressures calculated from the preceding data. They are expressed in *volts*, a unit of electric pressure whose value we shall explain later.

In Table I. the chemical change supposed is that of the oxidation of

TABLE I.—HEATS OF OXIDATION AND ELECTRIC PRESSURES OF VARIOUS METALS IN OXIDISING MEDIA.

Metal.	Weight Oxidised.	Heat of Oxidation in Calories.	Electric Pressures in an Oxidising Medium.
Magnesium ... ..	24 grams	143,900	3'13 volts
Potassium ... ..	78 "	139,600	3'03 "
Sodium ... ..	46 "	135,600	2'95 "
Calcium ... ..	40 "	131,000	2'85 "
Zinc ... ..	65'5 "	85,800	1'86 "
Tin ... ..	59 "	72,650	1'58 "
Hydrogen ... ..	2 "	68,400	1'56 "
Iron ... ..	56 "	68,240	1'48 "
Lead ... ..	207 "	50,300	1'09 "
Copper ... ..	63 "	37,200	'81 "
Mercury ... ..	200 "	20,700	'45 "
Silver... ..	216 "	5,900	'13 "

the metal named in the first column, and the resulting heat evolved or the electric pressure generated is given.

Since simple oxidation is seldom allowed to occur in voltaic cells in



which the ultimate chemical product is usually a metallic salt, Tables II. and III. have been compiled to exhibit the figures when sulphation or

TABLE II.—HEATS\* OF SULPHATION AND ELECTRIC PRESSURES OF VARIOUS METALS IN SULPHATING MEDIA.

Metal.	Weight Sulphated.	Heat of Sulphation in Calories.	Electric Pressures in a Sulphating Medium.
Potassium ... ..	78 grams	234,900	5'10 volts
Sodium ... ..	46 "	225,700	4'90 "
Calcium ... ..	40 "	219,800	4'78 "
Magnesium ... ..	24 "	219,300	4'76 "
Zinc ... ..	65'5 "	145,200	3'16 "
Iron ... ..	56 "	132,300	2'88 "
Cobalt ... ..	59 "	127,200	2'76 "
Nickel ... ..	59 "	126,100	2'74 "
Lead ... ..	207 "	112,900	2'45 "
Hydrogen ... ..	2 "	107,600 (sulphuric acid)	2'34 "
Copper ... ..	63 "	95,100	2'07 "
Silver ... ..	216 "	59,500	1'29 "

\* The heats given are those of aqueous solutions of the various salts (except in the case of lead sulphate), but do not include the heat of formation of  $\text{SO}_3$  (= 103,300 calories).

TABLE III.—HEATS OF CHLORIDATION AND ELECTRIC PRESSURES OF VARIOUS METALS IN CHLORIDISING MEDIA.

Metal.	Weight Chloridised.	Heat of Chloridation in Calories.	Electric Pressures in a Chloridising Medium.
Potassium ... ..	78 grams	199,800	4'34 volts
Sodium ... ..	46 "	192,800	4'19 "
Calcium ... ..	40 "	187,200	4'07 "
Magnesium ... ..	24 "	186,900	4'06 "
Aluminium ... ..	18 "	158,500	3'44 "
Zinc ... ..	65'5 "	112,800	2'45 "
Iron ... ..	56 "	100,000	2'17 "
Cobalt ... ..	59 "	94,800	2'06 "
Nickel ... ..	59 "	93,700	2'04 "
Tin ... ..	118 "	81,100	1'76 "
Hydrogen ... ..	2 "	78,600	1'71 "
Lead ... ..	207 "	76,000	1'65 "
Copper ... ..	63 "	62,700	1'36 "
Silver ... ..	216 "	58,800	1'28 "
Mercury ... ..	200 "	49,900	1'08 "

chloridation occur. The former is applicable to those cells in which sulphuric acid or a sulphate is the exciting liquid, and the latter to those in which hydrochloric acid or a chloride is used.

In using these tables, it must be remembered that the electric pressure tends to urge a current from the metal into the liquid, and therefore in a simple cell the resultant pressure is the *difference* between the pressures

developed by the two metals in the liquid employed. Thus in the copper-zinc-sulphuric acid cell the pressure for the sulphation of zinc is 3.16 volts, and that for the sulphation of copper 2.07 volts; the difference, 1.09 volts, thus calculated from thermal experiments only, is not far from the observed electric pressure of the actual cell.

To explain these phenomena two rival theories have been put forward, and have been the subjects of much discussion for over a century. According to the one longest maintained, the generation of electricity is to be explained by the mere contact of bodies with each other; according to the other, chemical processes are the cause of the electric current. The former is called the "contact" theory, and has been advocated by Volta, Gassiot, Kelvin, Hankel, Kohlrausch, and many others. The latter is called the "chemical" theory, and has been maintained by Faraday, De La Rive, Exner, and others.

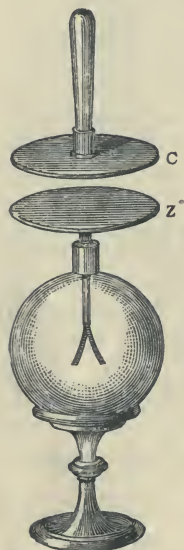

Fig. 136.—Volta's Condensing Electroscope.

**The Contact Theory.**—The contact theory was founded on Volta's fundamental experiment, and led to the scientific war that raged towards the latter end of the eighteenth century between Volta and Galvani and their followers. Galvani attributed the motions of the frog's leg to animal electricity; Volta, on the contrary, to metallic electricity—that is, to electricity generated by contact of two metals. According to this idea, the frog's leg is but a sensitive electroscope. Volta's so-called fundamental experiment may be made with his condensing electroscope (Fig. 136). For this purpose it may be constructed of two metal discs *z* and *c*, of zinc and copper respectively, *c* being attached to an insulating glass handle and *z* to the insulated rod of a gold leaf electroscope. If the disc *c* be placed on *z* and then lifted off, the gold leaves diverge, and on examination are found to be positively electrified. To

explain this we must remember that the two plates when close together form an air-condenser of great capacity; if, therefore, there is a contact difference of potential between *c* and *z*, though it may be but small in amount, the plates will receive large charges. On separating them the capacity falls rapidly, the potential-difference increases, and the potential of *z* rises, whilst some of the lines of force pass on to the gold leaves and cause them to deflect.

Similarly copper becomes negatively electrified when touched with a tin or iron plate, but positively electrified when touched with silver or platinum. It has been found that whatever metals are brought into contact with each other, they show, when separated, opposite electrifications; during the contact, then, a force must be called into play which causes positive

electricity to pass over from one metal to the other. This electromotive force, Helmholtz thinks, is to be sought in the difference of the force of attraction each metal possesses for electricity. The matter of the metal attracts the two electricities postulated by the two-fluid theory, and this attraction differs in strength according to the kind of electricity. Electromotive force acts in the same manner as molecular forces act—that is, at immeasurably small distances—whilst the electricities influence each other from finite distances.

When the two plates in Volta's experiment are separated, the copper plate has a negative and the zinc plate a positive electrical charge. In other words, the plates have a difference of potential. To prove that it really is so, Lord Kelvin devised the following experiment with an apparatus on the principle of his electrometer (Fig. 137). The aluminium

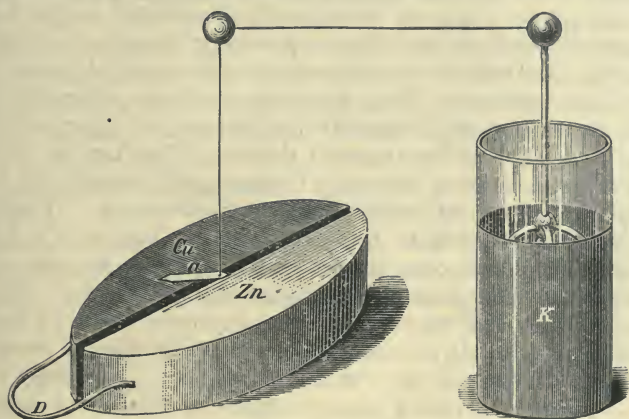

Fig. 137.—Different Potentials in Two Metals.

strip *a*, which we will call the needle, is suspended from a flexible wire in connection with a Leyden jar *K*. Under the needle, two plates (one of copper, the other of zinc) are arranged horizontally so that there is a small distance between the two, this space being parallel with the needle when in its normal position. When the jar is highly charged the needle will have a high potential, and influence the two plates. On account of the symmetrical position which *a* has relatively to the two plates, they will have the same potential, and attract *a* equally, consequently *a* will remain exactly midway between the plates. If now we connect the copper plate with the zinc plate by means of a wire *D*, the needle, if positively electrified, leaves its position, and moves towards the copper plate, thus showing that the copper is at a lower potential than the zinc, and therefore that the zinc is positively electrified relatively to the copper.

It may be useful to point out, that although in the contact series the



copper is negative in relation to the zinc, and the zinc positive in relation to the copper, yet in the voltaic cell represented in Fig. 135' we call the copper the positive pole and the zinc the negative pole. The reason for this will be seen by breaking the copper wire joining the two plates. The origin of the difference of potential will be at the junction of the piece of wire left in the zinc. This wire will have negative electricity, while the zinc, the copper, and the copper wire on the right will have positive. Hence, positive electricity, according to the contact theory, will flow from the zinc through the liquid to the copper, and from the copper through the wire to the zinc.

**The Chemical Theory.**—This theory attributes the current in a voltaic circuit entirely to chemical action, and places the seat of the *E. M. F.* at the place or places where chemical action is proceeding. Its advocates point to the energy changes to which we have already alluded, and to the approximate agreement between the electric pressures actually obtained with certain combinations and those calculated from the thermal values of the chemical changes involved. They also insist upon the agreement of the theory with the laws of the conservation of energy, an agreement which, they assert, does not hold for the rival theory. They say, by the mere contact of two metals no work is done. The energy of the electrical current would be generated out of nothing, which is impossible. Whenever a galvanic current is generated by immersing different metals in a fluid, we cannot help noticing such chemical processes. But how are we to make Volta's fundamental experiment agree with the chemical theory? We must not overlook the facts that the most sensitive apparatus has to be employed if the experiment is at all to succeed; that at the surface of every body gases condense, and that this layer or coating of gas is exceedingly difficult to remove. It has been shown experimentally by Exner and many subsequent experimenters that the difference of potentials between a metal and the air that surrounds it is proportional to the tendency of the metal to become oxidised by the air. The followers of the chemical theory, therefore, say Volta's fundamental experiment has nothing to do with two metals in contact, but two metals separated from each other by a layer of moisture or of gas. This layer, although only very thin, is sufficient to start a chemical action, and the thinness of it accounts for the scanty amount of electricity generated by this experiment, which on this view is due to the surface oxidation of the metals. During this chemical process the metal becomes negatively, the oxide layer positively, electrified, and the latter, being an insulator, retains its charge. If now the oxidised plate is touched with a clean metallic plate, the positive electrification of the oxide layer induces electrification on the clean metal plate. Volta's fundamental experiment, according to this explanation, would have to be considered an induction phenomenon.

It is possible that up to a certain point both parties are in the right.

The process may take place in such a manner that whenever the metals are brought to touch each other their electrical potentials are changed; that is to say, a distinct statical condition is produced whereby no kind of motion is required, and the work necessary to bring the two bodies into contact with each other is sufficient to produce this statical condition. This explanation would not be in opposition to the law of conservation of energy. The difference of electrical potential in the bodies becomes then the cause of a chemical process which is continuous. In this manner a lasting electric current may be produced. Cause and effect now strengthen each other, just as during combustion temperature is increased by oxidation, and the high temperature facilitates oxidation. Motion of electricity (that is, the electric current) is due, then, to a chemical process, but the original generation of the difference of electrical potential initiative of the chemical process may be due to the contact of metals.

**Volta's Contact Law.**—When metals differing from each other are brought into contact, we obtain different results both as to the kind of electrification as well as the difference of potentials. Volta found that iron, when in contact with zinc, becomes negatively electrified; the same takes place, but somewhat weaker, when iron is touched with lead or tin. When, however, iron is touched by copper or silver, it becomes positively electrified. Volta, Seebeck, Pfaff, and others have investigated the behaviour of many metals and alloys when in contact with each other. The following lists are so arranged that those metals first on the list become positively electrified when touched by any taking rank after them :

*According to Volta.*

+ Zinc  
 lead  
 tin  
 iron  
 copper  
 silver  
 gold  
 graphite  
 — manganese ore.

*According to Pfaff (1837).*

+ zinc  
 cadmium  
 tin  
 lead  
 tungsten  
 iron  
 bismuth  
 antimony  
 copper  
 silver  
 gold  
 uranium  
 tellurium  
 platinum  
 — palladium.

Volta laid down a law regarding the position of the metals in his table which may be stated as follows: *The difference of potential between any two metals is equal to the sum of the differences of potentials of all the intermediate members of the series*; consequently, it is immaterial for the total effect

whether the first and the last are brought into contact directly, or whether the contact is brought about by means of all or any of the intermediate metals. We can easily see this from the numerical values which Volta obtained. If, for instance, we bring silver and zinc to touch each other, we obtain the difference value 12; if now we place upon the zinc plate a lead plate, then tin, iron, copper, and finally the silver plate, we obtain for difference values 5, 1, 3, 2, 1, the sum of which is 12. Volta's law further asserts that when any number of metals are brought into contact with each other, but so that the chain closes with the metal with which it was begun, the total difference must be nought. We obtain for zinc, lead, tin, iron, and finally zinc the following values :

For zinc and lead + 5  
 „ lead and tin + 1  
 „ tin and iron + 3  
 „ iron and zinc - 9.

The sum for the values of the three first contacts is equal to + 9, the last value is - 9. Hence the whole sum is nought. Volta's contact law does not hold when an acid is included in the circuit, there being then an unbalanced electromotive force which gives rise to a current.

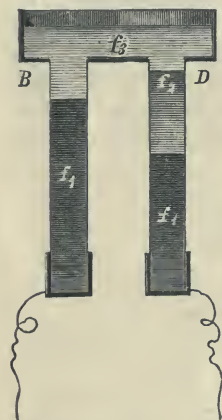

Fig. 138.—Production of an E. M. F. by Liquids in Contact.

In addition to the contact difference of potential observed when two metals are in contact, Nobili showed that two liquids in contact also develop a difference of potential, and Fechner, Wild, and others have investigated the subject more thoroughly. Wild in his experiments attached two glass tubes B D (Fig. 138) to the bottom of a little wooden box; the glass tubes terminated in copper caps, which were in connection with a galvanometer. Before each experiment the copper bottoms of the glass tubes had to be carefully examined, to see whether they would not generate a current when in contact with any one fluid—that is, whether they were perfectly homogeneous; then liquid  $f_1$  was introduced; after that liquid  $f_2$ . Care was taken not to mix  $f_1$  with  $f_2$ . Finally, liquid  $f_3$  was introduced under the same precautions. With

this arrangement a marked difference of potential was easily shown by a galvanometer placed in the circuit between the two copper caps or terminals.

#### IV.—DEVELOPMENT OF THE PRIMARY CELL.

The few cells already described (pages 148 and 149) exhibit serious defects when used as current generators, especially if the currents required are heavy ones. Apart from questions of economy, these defects are traceable to two causes, namely, *polarisation* and *local action*.



**Polarisation.**—The cause of this is due to one of the fundamental properties of the current, *i.e.* the chemical effect referred to on page 144. A simple voltaic cell (Fig. 135) is essentially an arrangement in which this chemical effect must be manifested. The liquid used is an electrolyte, and the chemical effect must appear where the current enters and leaves it. As we shall see later, if we pass a current through sulphuric acid, using platinum or non-corrodible plates at the points of entry and emergence, oxygen gas will be liberated at the place where the current enters and hydrogen gas where the current leaves.

The same action takes place in a voltaic cell when the circuit is closed. Where the current enters, at the zinc plate, oxygen is formed, which combines with the zinc, forming zinc oxide, which becomes zinc sulphate in presence of the sulphuric acid. At the copper plate, where the current leaves, hydrogen is formed, but as this element does not, under such circumstances, combine with copper, it simply adheres to the copper plate, which more or less quickly becomes coated with it.

The result is that eventually, instead of the voltaic couple being zinc and copper immersed in sulphuric acid, it becomes zinc and hydrogen (the copper being shielded by its gaseous coat), and an examination of Table II. will show that the E. M. F. of this combination of materials is 0.82 volts as against 1.09 volts for the zinc-copper couple. Consequently the current rapidly falls off, an effect which is increased by the fact that the presence of the hydrogen also increases the resistance of the circuit, a physical quantity the meaning of which we have yet to explain.

Various methods have been devised for eliminating, or at least minimising, these injurious effects. It is obvious that if the hydrogen can be removed as quickly as it is formed, or, better still, if its formation can be avoided altogether, the E. M. F. will not fall off.

The actual removal of the hydrogen is sometimes attempted by mechanically brushing it off with brushes or some other device by which the surface of the negative (or copper) plate is being continually rubbed, and thus the accumulation of the gas is prevented. In 1840 Smee, whose battery is still used for small electroplating work, attained the desired end fairly well by substituting a plate of platinised silver (silver coated with platinum black) for the copper plate. Either owing to the occlusion of the hydrogen by the platinum, or perhaps on account of the mechanical roughness of the surface, this cell does not polarise nearly so rapidly as an ordinary zinc-copper cell. An early form of such a cell is shown in Fig. 139, in which the platinised silver plate Ag. is clamped between, but well insulated from, two heavy zinc plates Zn. Proper terminals are provided, and the plates are immersed in a glass vessel containing dilute sulphuric acid. The vessel is much deeper than the plates, so that the zinc sulphate formed may fall to the bottom. In Fig. 140 is shown a battery of six such cells joined up in

series,\* and with a mechanical arrangement for lifting the whole of the plates out of the acid when the battery is not in use, so as to minimise the evil effects of local action, the other defect that we have mentioned.

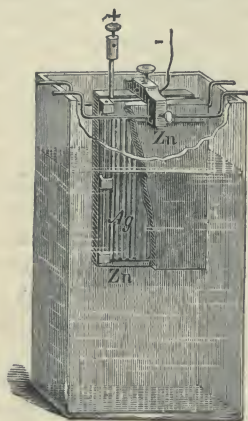

Fig. 139.—Smee's Cell.

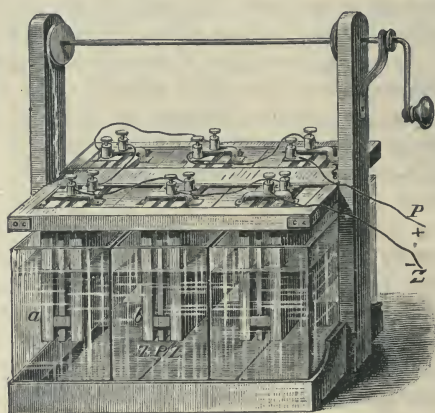

Fig. 140.—Smee's Battery.

The mechanical method of removing the deposited hydrogen is certainly crude, and is therefore seldom used. A much better method is the chemical method, the principle of which is to surround the negative element (*i.e.* the copper) with a substance rich in oxygen, held but loosely in combination, and with which therefore it readily parts. This oxygen, if in sufficient quantity, attacks the hydrogen at the moment of its formation—that is, when it is *nascent*—and oxidises it to water, in which form it is harmless. The substances are known as *depolarisers*, and the ones most commonly used are nitric acid, chromic acid (usually as obtained from bichromate of potash), and peroxide of manganese. The first two named have the disadvantage that they oxidise zinc, if they are allowed to come into contact with it, even though no current be passing, and therefore it is necessary to separate the zinc from the depolariser either by placing it in a separate vessel or by removing it from the liquid when the cell is not in use.

**Nitric Acid Cells.**—*Grove's Cell.*—One of the earliest of the cells of this class was devised in 1839 by Sir William Grove, Master of the Mint. An early form of Grove's cell is shown in Figs. 141 and 142. It consists of two vessels, one within the other, and two acids respectively surrounding the two metal plates. The outer vessel, in which the zinc plate is placed, is usually made of glass, porcelain, or an acid-resisting composition. Inside this zinc plate comes the porous pot which holds the platinum plate, bent in the shape of an S. These porous pots, made of unglazed earthenware, are largely used in primary cells. They mechanically separate the liquids inside and

\* For the meaning of this term see page 184.

outside from one another whilst allowing the electric current to flow along connecting filaments of liquid in the capillary passages with which they are permeated. The glass vessel is filled with diluted  $\text{H}_2\text{SO}_4$ , and the porous pot with concentrated  $\text{HNO}_3$ . When the battery is in action, water is decomposed and the hydrogen, reaching the nitric acid ( $\text{HNO}_3$ ) through the porous pot, takes up some of its oxygen to form water.

The chemical change may be expressed by one or other of the following equations, starting with two molecules of nitric acid :

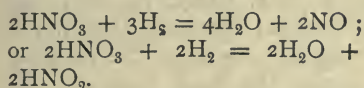

In the second case the  $2\text{HNO}_2$  breaks up into

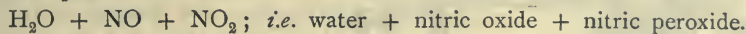

The nitric oxide forms red fumes when it comes into contact with common air. Zinc sulphate is formed in the outer vessel, but the water and nitric oxides remain in the porous vessel. The action of the cell remains constant only so long as there is undecomposed nitric acid in contact with the platinum plate. The disadvantages of this cell are the nitrous fumes and the high price of platinum.

The cell illustrated was ultimately replaced by a much more compact form, in which both the outer vessel and the porous pot took narrow flat shapes, and the zinc was bent into the shape shown in Fig. 143, very similar to that used in Wollaston's battery (Fig. 133). The S-shaped platinum was replaced by a thin flat strip which hung down inside the porous pot, which in its turn was placed in the bend of the zinc. The liquids used were the same as in the original form. A battery of eight such cells as set up by Messrs. Griffin & Sons is shown in Fig. 144.

*Bunsen's Cell.* — The almost prohibitive cost of the platinum plates in the Grove cell led to the invention of the Bunsen cell, in which the platinum was replaced by hard retort carbon, the other materials remaining the same. Fig. 145 represents the form which is given to the cell when it is intended to be joined up with other cells to form a battery. The carbon plate, surrounded by nitric acid, is placed in the porous pot,

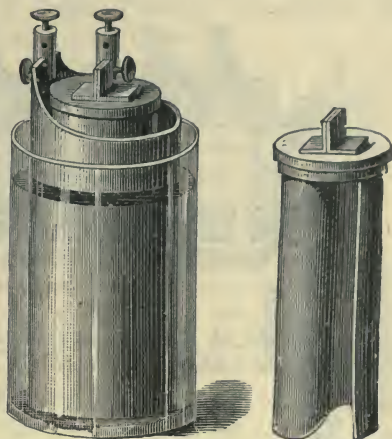

Fig. 141.—A Grove's Cell. Fig. 142.—The Platinum.

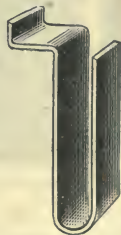

Fig. 143.—Zinc Plate for Grove's Cell.



whilst the zinc and the sulphuric acid are in the outer vessel. The great objection to the Bunsen cell is, as in the Grove cell, the generation of noxious fumes. In spite of this, however, it has been very frequently

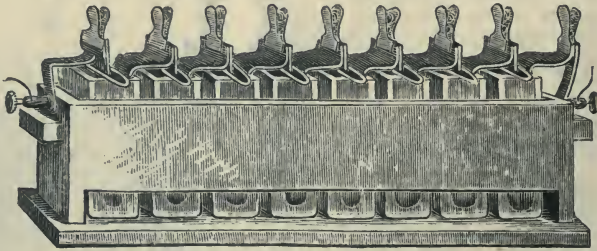

Fig. 144.—Battery of Grove's Cells.

used on account of its constancy, its high E. M. F. (about 1.9 volt), and small resistance. The Bunsen cell is less constant than the Daniell cell

(page 170), owing to the chemical changes the fluids undergo. To diminish the resistance and volume of the acids required, and also to save space, the Bunsen, as well as the Grove cell, has been constructed of plates arranged in rectangular vessels. As the zinc and carbon plates may be laid very close to each other, the resistance may be diminished to about 0.060 ohm. Rouse substituted a lead cylinder for the zinc cylinder, and Maiche an iron cylinder, which he placed in water acidulated with nitric acid (1 part in 100). This arrangement causes greater constancy and diminishes the evolution

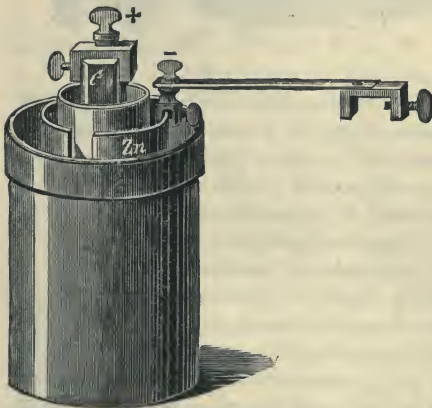

Fig. 145.—A Bunsen Cell.

of gas, but reduces the E. M. F. to 0.85 of a volt. Several inventors have successfully replaced the platinum by iron, but always at the sacrifice of the high E. M. F.

Schonbein made use of *cast-iron* pots and a liquid consisting of two parts of concentrated nitric acid and one part of sulphuric acid, with an earthenware pot containing diluted sulphuric acid, the zinc being placed in the latter liquid. As sulphuric acid takes away the elements of water from nitric acid, it prevents the latter from becoming too diluted, which is important on account of the action of dilute acid on

the iron. By using concentrated nitric acid, iron becomes what is called "passive." In this condition alone can it be utilised in a galvanic cell; when the acid is diluted beyond a certain limit, the iron is acted upon.

**Chromic Acid or Bichromate Cells.**—Chromic acid, which parts easily with a large proportion of its oxygen, is another of the fluids which, more or less, prevent polarisation. Warrington first used chromic acid with electrodes of platinum and zinc, forming a kind of Grove cell in which the nitric acid was replaced by chromic acid. For carbon-zinc cells, Bunsen, Laeson, and Poggendorff have also used chromic acid, or mixtures which produce it. For this purpose potassium bichromate, sulphuric acid, and water are used, when potassium sulphate is formed and chromic acid set free. The sulphuric acid not only combines with the potassium and sets free the chromic acid, but also dissolves the zinc, therefore if too much sulphuric acid be added, the zinc will be dissolved when the cell is not sending a current.

*The Bichromate Bottle Cell.*—Grenet's bichromate cell (Fig. 146) has bichromate of potash added to sulphuric acid. The cell is usually of a flask or bottle shape. The zinc plate *z* is in the middle, and a pair of carbon plates *k, k*, one on each side of the zinc, are joined at the top and constitute the positive pole. The zinc plate *z* is attached to a rod *a*, by which it can be lifted out of the solution when the cell is not in use. This is necessary for the reason just given, namely, that the solution acts on the zinc even when the circuit is broken.



Fig. 146.—The Grenet or Flask Cell.

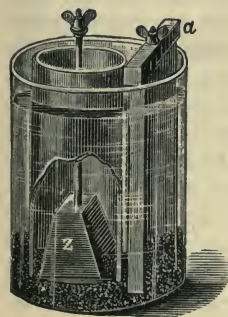

Fig. 147.—Fuller's Patent Mercury Bichromate Cell.

*The Fuller Cell.*—The Fuller cell, which is a convenient cell for laboratory use and has also been extensively used by the English Telegraph Department since 1871, is a chromic acid cell; it is represented in Fig. 147, in which *z* is the zinc electrode, which is in the shape of a rod flattened at the end or attached to a pyramidal foot. This rod is placed in a porous vessel, and in order to have it well amalgamated, about 30 grammes (or about one ounce) of mercury are placed in the earthenware pot. The

carbon plate *a* is outside the porous diaphragm, and is 6 inches long by 2 inches wide. The porous pot containing the zinc rod is placed in a glass or earthenware vessel, which is filled to within two inches of the top with a solution of 90 grammes (3 ounces) of bichromate of potash in one part of sulphuric acid and nine parts of water. The upper part of the rod is covered with wax. Water only is poured on the mercury in

the inner cell. This cell produces twice the electromotive force of a Daniell cell, with a smaller resistance under similar conditions. The addition of the mercury is the essential feature of the battery, and to it the disappearance of the main objections against the old bichromate form is chiefly due. The zinc plate is, in this way, kept permanently amalgamated so long as it lasts; and not only is the internal resistance of the battery largely diminished, but its constancy is to a great extent insured. The action (after the battery is charged, and the cells connected) commences almost immediately, and reaches a maximum in the course of a few hours.

On an ordinary working circuit no extra crystals will be required for a period of six months, after the battery is once set up; nor, indeed, so long as the bichromate solution remains of an orange colour. Only when it begins to assume a blue tint need crystals be added to it.

The electromotive force of the combination is equal to about 2 volts; the internal resistance, by varying the thickness of the porous vessel and the strength of the solution, may be made to vary from 0.5 of an ohm up to 4 ohms, according to the work which the battery is called upon to perform.

**Manganese Dioxide Cells.**—A depolariser which has, perhaps, been more extensively used than any other is the mineral pyrolusite, which chemically is a dioxide of manganese ( $MnO_2$ ). De La Rue recommended its use, but the idea was

practically worked out by Leclanché, who devoted many years to improving the cell which is known by his name. It is, without doubt, due to the great care with which every detail was worked out by the inventor that the great practical success of the cell in certain classes of work was attained.

*Leclanché's Cell.*—One of the forms of this cell which has been very widely used, especially for domestic work, is represented in Fig. 148. The four-sided form is preferred to the round, because in this manner, when a number are placed together to form a battery, the space is more completely utilised. The glass vessel contains a porous cell of cylindrical shape, the diameter of which is such as almost to fill the space in the glass vessel so as to prevent the evaporation of the fluid as much as possible. The function of this porous cell is not, as in those previously described, to separate two liquids, but simply act as a mechanical support for the solid particles surrounding the carbon plate. The zinc rod is placed as shown in the figure. The porous cell contains a carbon block surrounded by a mixture of small pieces of carbon and manganese dioxide, the top being covered with pitch, leaving one small hole so as to allow air and gas to

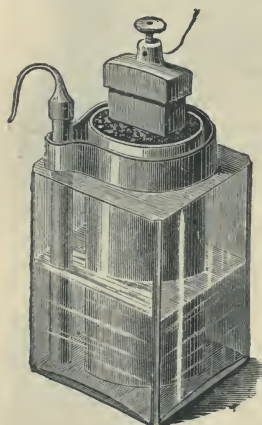

Fig. 148.—Leclanché's Cell.



pass through. The glass vessel is half filled with a strong solution of ammonium chloride (sal-ammoniac). A leaden cap carrying a binding screw is attached to the top of the block of carbon in order to obtain a good contact. The zinc rod ought to be neither cast nor wrought, but drawn out; the reason for this lies in the different properties of the three kinds. Through casting zinc becomes crystalline, brittle, and not homogeneous in structure. Owing to the porous, crystalline condition, the zinc surface would be unnecessarily increased, which would hasten the solution of the zinc; besides, cast zinc is seldom pure, but contains small quantities of many other metals, such as lead, etc. It will be shown presently that these metals form minute galvanic couples with the zinc as soon as it is dipped into a fluid, and thus considerably aid the useless solution of the zinc. Wrought zinc would have nearly the same properties, although zinc, when wrought, has to be purer to stand the process; however, the best material is zinc which has been drawn out. Leclanché uses amalgamated zinc rods, so as to obtain a uniform wearing-out of the electrode. If the wear be not uniform, rough places will be produced which will facilitate the formation of crystals, and not only increase the resistance of the cells, but also diminish the surface of the electrode. The negative carbon electrode, too, requires attention with regard to certain conditions. For filling the porous pot every manganese ore cannot be used, but only that modification known under the name of pyrolusite. Both the carbon and pyrolusite ought to be rough-grained, but polarisation is avoided best by using big grains of carbon and powdered pyrolusite, because then the hydrogen meets the pyrolusite at every point polarised, which is not always the case when large grains are used. Greater E. M. F. is, however, obtained by using grained and not powdered pyrolusite. The solution of ammonium chloride is concentrated, because by its use the resistance is diminished, and a concentrated solution is better able to take up the salts produced during the use of the cell, and to prevent the separation of the salts at the electrodes, and consequent weakening of the current.

The change that takes place is as follows: The zinc, sal-ammoniac, and pyrolusite are changed into zinc chloride, water, and ammonia, and an oxide of manganese less rich in oxygen.  $Zn, 2NH_4Cl, 2MnO_2$  are changed into  $ZnCl_2, H_2O + 2NH_3, Mn_2O_3$ .

This form of the cell is usually constructed in three different sizes, the approximate dimensions and particulars of which are given in the following table:—

Size.	Porous Pot.		E.M.F. Volts.	Resistance (approximate). Ohms.
	Diameter.	Height.		
No. 1	3'4	6'0	1'5	3 or 4
" 2	3'0	6'0	1'5	5 to 6
" 3	2'4	4'4	1'5	9 to 10

*Agglomerate Block Leclanché Cells.*—By using a diaphragm the resistance in the cell is considerably increased, and is further increased when the grains of the carbon and pyrolusite mixture are not pressed close together, because the fluid conducts worse than the mixture. Leclanché tried

to avoid using a diaphragm by altering the carbon electrode. In order to obtain a compact mass, gum is added to the mixture, which is heated to  $100^{\circ}$  C. under a pressure of 300 atmospheres. Solid blocks, known as agglomerate blocks, are produced in this manner, consisting of 40 parts pyrolusite, 52 parts carbon, 5 parts gum, and 3 parts potassium bisulphate. The latter facilitates the solution of the zinc salts which enter the pores. Leclanché fastened the carbon plate to these by means of caoutchouc rings, as shown in Fig. 149. If necessary the reduction of the resistance may be increased by using several blocks surrounding a thick polygonal carbon rod. The zinc electrode consists of a zinc rod held in position by caoutchouc rings and separated from the carbon by means of a piece of wood. The disadvantage of this form

is that the agglomerate blocks slowly disintegrate and eventually crumble to pieces.

Another pattern of Leclanché cell as made by Messrs. Siemens Bros. is shown in Fig. 150. In this cell, in order to reduce still further the resistance and at the same time to supply a larger quantity of zinc, the fuel of the cell, the electro-positive zinc electrode, is in the form of a cylinder surrounding the electro-negative carbon electrode. From one side of the cylinder there rises a substantial lug, which is bent over in the form of a hook and supports the electrode from the top rim of the glass containing vessel. The wire for making connection is soldered to the lug, the joint being carefully painted with insulating paint to prevent local action; the top rim of the glass vessel is also painted to stop the creeping of salts. Two agglomerate blocks are clamped on to the carbon with rubber bands and act as depolarisers. The resistance of a cell of this pattern, 6 in. high and  $4\frac{1}{2}$  in. in diameter, is about 0.7 ohm, the E. M. F. being about 1.55 volts.

The Leclanché cell in its various forms has the great merit of requiring

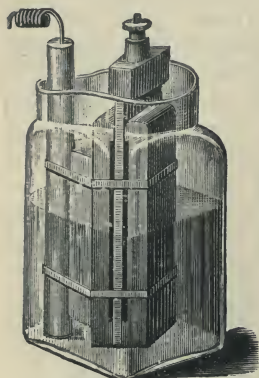

Fig. 149.—Agglomerate Leclanché's Cell.

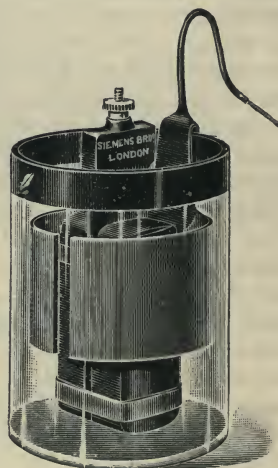

Fig. 150.—Low Resistance Leclanché Cell.

very little attention, but the depolarisation is not nearly so good as in some of the other cells described. With moderately large currents it polarises very rapidly, but recovers its E. M. F. if left standing idle for some time. It is therefore well adapted for intermittent work, such as electric bells and telephone calls, also for telegraphing on lines on which there is not much traffic. It should also be noted that the cell does not contain any corrosive acids, and that it does not emit noxious fumes when working. Further, the electrolyte, sal-ammoniac, is readily procurable, but, if not available, on an emergency it may be replaced by a solution of common table salt, sodium chloride.

**Dry Cells.**—Various modifications of the Leclanché cell completely sealed up, and usually described as “*Dry*” cells, have been brought forward and extensively used during the last few years. The term “dry” must not be taken literally, for a voltaic cell must contain an electrolytic liquid, though the quantity may be small, as in Volta’s pile, or though there may be more liquid electrolyte, as in the cells under consideration; the whole of the active material, however, of the cell may be so enclosed that no moisture can be detected without breaking open the cell. To diminish the liability of leakage both the electrolyte and the depolariser are usually mixed with other materials to form a kind of paste more or less stiff. The final seal, as a rule, consists of bituminous material, but the cell is not quite hermetically closed, a small vent being usually left for the escape of the ammonia gas, which we have seen is given off in small quantities in the working of a Leclanché cell. Should this vent be omitted or become choked the pressure of the gas will in most cases burst the cell open after it has been in use for some little time.

Cells of this type have been invented by Helleesen, Obach, Burnley, Lessing, and many others. Besides producing a compact and portable cell the efforts of inventors have been chiefly directed to diminishing the internal resistance and increasing the effectiveness of the depolariser so that the E. M. F. may be well maintained during use.

*The Obach Cell.*—One of the most widely used dry cells is that invented by Dr. Obach; a cross section is shown in Fig. 151, and the external appearance of one of the patterns in Fig. 152. In this cell the zinc A forms the outer vessel, being mounted on an insulating base B, which may be of wood, but is usually made of a compound of asphalt moulded to the required shape when hot. The carbon rod c is placed in the centre of the cell, and

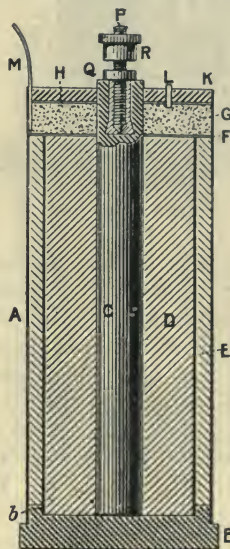

Fig. 151.—Section of Obach's Cell.



is surrounded by the depolarising mixture *D*. The latter consists of manganese dioxide and plumbago in nearly equal proportions made into a paste with 1 per cent. of gum tragacanth, and then pressed through a die into the required form. This is such as to surround the carbon *C* and to fit the projection *b* of the insulating base; it is wrapped round with paper or textile fabric. The electrolyte occupies the space between *D* and the zinc outer vessel; it is made up of about 85 per cent. of plaster of Paris and 15 per cent. of flour mixed to a thin paste with a solution of sal-ammoniac. A paper ring *F* is placed over the depolariser and the electrolyte, and above this is a layer *G* of granules of ground cork or other non-hygroscopic material. Then comes another paper ring *H*, and above this the bituminous seal *K*, through which the glass tube *L* is passed to act as a vent for the gases liberated by the action of the cell.



Fig. 152.—Obach's Dry Cell.

The method of securing the metal binding screw to the carbon so as to ensure good electrical contact is worthy of notice. A cylindrical hole widened at the bottom and with narrow grooves on either side is cut in the carbon. The screw *P* is then held in the centre of the hole, and a molten fusible alloy of bismuth, lead, and tin is poured in round it. The alloy expands on solidifying and grips the screw *P* tightly in the hole. Owing to the enlargement at the bottom and the grooves at the side it is not easy to draw out the plug or to twist it round. The nuts *Q* and *R* are then placed on *P*, the former being screwed on tightly. The terminal *M* for the zinc is a piece of copper wire or strip soldered on at the top in the space *G*. The junction should be protected from local action by being covered with some insulating material.

The Obach cell was tested in 1894 by Professor Jamieson of Glasgow and found to give good results. The output of a *B* cell weighing 2 lb. 10 oz. was 17·4 ampere hours, with currents ranging from 0·024 ampere to 0·384 ampere, the tests extending over four days with long intervals of rest intervening. An *A* cell weighing 4 lb. 6 oz. was similarly found to give 34·4 ampere hours, its resistance varying during the test between 0·027 ohm and 0·416 ohm. With the *B* cell the current was 4 minutes on, and then the cell rested for 4 minutes; with the *A* cell the corresponding intervals were 5 minutes. These rests were independent of the long rests between the different daily tests. An exhausted *A* cell was afterwards charged in a similar manner to a secondary battery (*see* page 207) with a current of 2 amperes for 7 hours, when its *E. M. F.* rose from 0·47 volt to 1·444 volts; it was then discharged through a constant resistance

of 5 ohms for 27 hours, during which the current fell from 0.259 ampere to 0.096 ampere. The total ampere hours and energy of the output are not given; it would have been interesting to compare them with the 14 ampere hours and the energy put in so as to deduce the approximate efficiency of the cell as a secondary cell. Sweeping deductions, however, should not be made from tests on single cells, which may be better or worse than the average of a parcel.

*The Lessing Cell.*—A sectional illustration of this cell, invented by Dr. A. Lessing, is given in Fig. 153. The outer containing vessel P P is of porcelain, immediately within which is placed a cylinder z of sheet zinc. In forming the cylinder a strip T is so far cut from the sheet without being completely severed that on being bent back it can be used for leading the current into the cell from the negative binding screw w. In this way all soldering or riveting inside the cell and consequent risk of local action is avoided. The negative plate c is a flat piece of carbon surrounded by manganese dioxide contained in a bag B B of coarse textile material bound round with thread. In the space between the bag and the zinc is the electrolyte, sal-ammoniac solution, thickened with flour, etc. A fairly thick layer s of sawdust covers the working part of the cell, and above this comes the bituminous seal A. Through the two latter the vent tube v v is passed for the purpose already explained. This ventilating tube is usually made of lead, so that it may be hammered up to prevent the liquid escaping whilst the cell is carried about; it can easily be opened out when the cell is required for use.

Experiments made by the author on the Lessing cell show that for ordinary telegraphic or ringing-up currents it is remarkably constant. When discharged through a constant resistance with such a current for 4 minutes at a time, with intervals of 6 minutes for rest, the current only fell 9.6 per cent. of its initial value in 380 hours, and other tests showed that the cells could have been discharged in this way for about 1,200 hours before being exhausted. It was also found that similar currents, *i.e.* from 25 to 28 milli-amperes, could be kept on continuously without the circuit being broken for 260 hours or longer. It was possible to draw much heavier currents from the cells for shorter periods, either continuously or intermittently, without any signs of distress, such as bursting or mechanical leakage, being apparent on the outside. Thus a current of nearly 500 milli-amperes (0.5 ampere) was kept on continuously through a constant external resistance for six hours with a fall of less than 7 per cent.

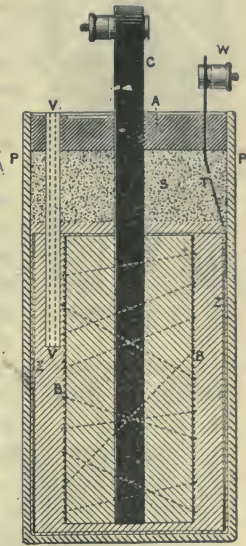

Fig. 153.—Section of Lessing's Cell.



The type of Lessing cell experimented upon was 6.3 inches high and 3.1 inches in diameter; it weighed about 3 lb. 2 oz. The E. M. F. is that of cells of the Leclanché type, namely, about 1.5 volts, and the resistance averages less than 0.2 ohm for cells in good condition, a remarkably low figure for so small a cell. The experiments conclusively show that the cell, besides being more portable and cleanly, does not polarise under severe conditions of test in the same way as an ordinary open type Leclanché. An external view of it is given in Fig. 154.



Fig. 154.—Lessing's Dry Cell.

Other good forms of dry cells have been brought out from time to time, notably the Gassner, the Hellesen (in which special attention is paid to ventilation), the Burnley (or E.C.C.), etc. etc., but considerations of space do not permit of their description in detail.

**Electro-Chemical Depolarisation.**—A third method of avoiding the evils of polarisation consists in selecting such a combination of liquids and metals that the chemical effect of the current at the negative plate of the battery does not alter the combination, and therefore does not vary the effective E. M. F. of the cell. The earliest and best attempt to apply

this method was in the cell devised by Prof. Daniell, of King's College, London, in 1836. In this cell the negative plate is of copper, and is surrounded by a saturated solution of sulphate of copper. The chemical effect of the current at this plate consists in plating copper from the solution on to the copper plate, thus leaving the combination unchanged and attaining the object referred to above.

The combination adopted by Daniell has proved so effective and convenient that almost endless varieties of his cell have been invented. We select two only for description here.

*Daniell's Cell.*—This in its original form is shown in Fig. 155, where *b* is a copper jar forming the + pole, and containing a saturated solution of sulphate of copper; *c* is a porous cell of some kind, which, in the cell represented, consists of a "membranous tube formed of part of the gullet of an ox." This porous cell contains a zinc cylinder in the middle, connected to the - pole. The liquid *o o* in the closed porous cell is dilute sulphuric acid, supplied

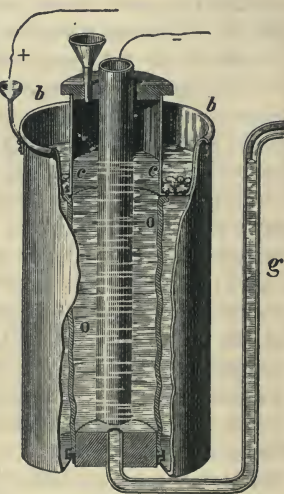

Fig. 155.—Daniell's Cell.



through the small funnel. The height of this liquid could be seen by means of the tube *g*, through which also the superfluous acid could be drawn off.

It will be seen, therefore, that the Daniell's element consists of an inner and outer cell, separated by a porous partition; copper and zinc being the metals. The copper does not waste, and may therefore be used for the outer cell, although this is not an essential feature. The porous cell may be made of unglazed porous porcelain, or of lighter material, such as parchment, or even of brown paper. When the amalgamated zinc is placed in the inner cell, and the copper plate forms the outer receptacle, the liquid in the inner cell is dilute sulphuric acid, and that in the outer cell is a saturated solution of copper sulphate or blue vitriol. It is desirable that this solution should be *saturated*, that is, should contain as much copper sulphate as it will dissolve, and, as the action decomposes this compound, spare crystals of the substance must be placed in a cage at the top of the liquid. These will gradually dissolve as the liquid becomes impoverished. The action when a current is flowing is as follows: Zinc dissolves in the dilute  $H_2SO_4$ , forming  $Zn SO_4$ , and liberating H. The freed atoms of H, however, do not reach the copper, but being handed on to the porous cell, through the pores of which they pass, they replace copper in the copper sulphate. The result is that pure copper instead of hydrogen is deposited on the outer plate, which therefore thickens. Hence

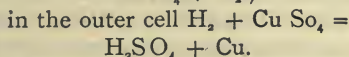
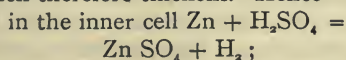

Fig. 156 represents a modification of the cell, having the copper in the inner cell and the zinc in the outer cell. Zn is the zinc cylinder placed in a glass vessel, *t* is the porous pot into which the copper rod *c* dips. The copper carries a little sieve *D*, to hold crystals of sulphate of copper. Each copper rod is connected with the next zinc cylinder by means of a wire *a*.

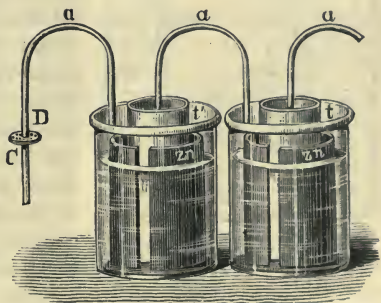

Fig. 156.—Daniell's Cells.

Some of the other numerous forms of Daniell's cell used for special purposes will be described in the technological section. We shall also describe later (*see* Chapter IX.) the forms of voltaic cells which are used as standards of E. M. F.

**Local Action.**—This defect of the voltaic cell is due to the presence of impurities in the metal plates, and especially in the zinc. For instance, suppose a small granule of iron *F* (Fig. 157) is embedded in the zinc

Zn and becomes exposed to the action of the exciting liquid. Iron being electro-negative to zinc, or, in other words, being differently acted on by the exciting liquid, the three form a miniature voltaic cell, the circuit of which is closed through the mass of the zinc not exposed to the liquid. In this circuit, therefore, an electric current, some of the paths of which are shown by the curves c c, flows and causes the zinc to be dissolved in the neighbourhood of the iron, even when the general circuit of the large cell, of which this minute circuit forms a part, is not closed. The difficulty would be overcome by using chemically pure

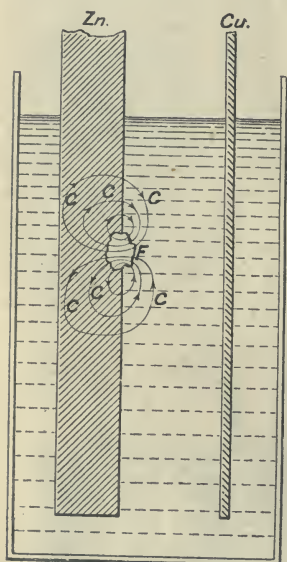

Fig. 157.—Local Action.

zinc, but this would be too expensive for ordinary use. Kemp had observed, however, in 1828 that zinc well amalgamated with mercury will not decompose acidulated water. Sturgeon, in 1830, therefore proposed that the zinc plates in voltaic cells should be well amalgamated, and this simple process was found to be thoroughly effective in preventing the local action described above. In fact, amalgamated zinc was found to behave electrically like chemically pure zinc.

Local action may, however, be set up in a cell which is initially free from it, if the cell be not properly attended to and kept in good condition. If we examine the porous earthenware vessel of a Daniell cell that has been in use for some time, we find that figures resembling the foliage and branches of trees, or little crystals, cover its surface. These are crystals of copper. The copper separated out in this manner sometimes goes through the porous cell, and is then in direct contact with the zinc, forming galvanic couples, which, producing only local action, decompose the zinc, but do no useful work. The

deposition of copper on the surface of the diaphragm is sometimes caused by the zinc residue which coats the cell. This sediment consists of iron, lead, copper, carbon, etc., which dissolve but slowly in the dilute sulphuric acid, if indeed they dissolve at all. To prevent this the porous pot is sometimes replaced by parchment. If the cell is arranged so that the zinc together with the sulphuric acid is inside the porous pot, the separation of copper may be prevented by having the zinc placed in the middle of the pot and the bottom of the diaphragm coated with wax. The zinc residue now remains at the bottom, and the solution of copper sulphate cannot pass through to it.

Similar deleterious effects develop in some other classes of cells if they are not attended to whilst in use. It is one of the merits of

the Leclanché cell that it is remarkably free from defects of this kind, and that it may be used for long periods of time with a minimum of attention.

V.—THE THERMAL PRODUCTION OF THE ELECTRIC CURRENT.

The chemical method of producing an electric current depends so intimately on the same phenomena which are manifested in the chemical effect of the current that it is difficult to deal with the two separately, and the foregoing pages will be better understood when those relating to the chemical effect (pp. 190 to 221) have been perused. When, however, we turn to the thermal method of producing a current, we have to deal with a set of phenomena which are quite distinct from those relating to what is *par excellence* the heating effect. The latter are concerned with the production of heat by a process of a *frictional* nature, which is *irreversible* and cannot be used for the purpose of restoring the heat energy to the form of current energy. There are, however, under special circumstances, other heating effects, small in magnitude and not always apparent throughout a circuit, but only where certain conditions are fulfilled. These effects are reversible, and by taking advantage of this reversibility the production of an electric current directly from heat energy is possible. The effects are usually referred to under the title of

THERMO-ELECTRICITY.

**The Peltier Effect.**—Peltier discovered in 1834 that when an electric current was passed across a junction of dissimilar metals, such as antimony and bismuth, the junction was either heated or cooled according to the direction of the current. If the current passed in one direction the junction was cooled, if in the other direction the junction was heated, this heating being in addition to the ordinary heating caused by the passage of a current through a homogeneous conductor. Peltier's method, as modified by Lenz, for showing this effect is illustrated in Fig. 158. Bars A and B of antimony and bismuth are soldered together at their centres, and two adjacent ends *a* and *b* of the cross so formed are connected

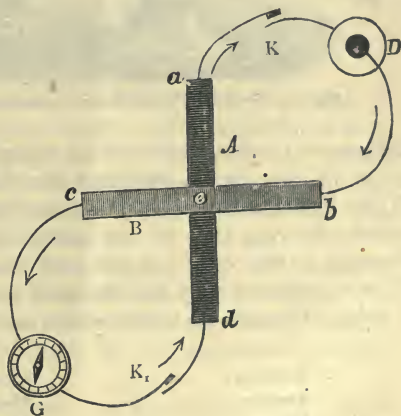

Fig. 158.—Peltier's Cross.

to the poles of a battery D through the key K. A hole *e* is bored out at the crossing point, the cross being first reduced to  $0^{\circ}$  C. by immersion in melting ice, a small quantity of water is introduced into the hole *e*, and



the battery circuit closed so that the current passes in the direction  $D\delta eaKD$ , and therefore across the junction of the two metals from the bismuth to the antimony. Lenz found that in five minutes the water in the hole was frozen and its temperature lowered to  $-4^{\circ}\text{C}$ . Peltier demonstrated the cooling effect by using a differential thermometer, and later on by making use of the Seebeck effect discovered twelve years earlier.

**The Seebeck Effect.**—This effect, which, historically, was the starting point of the science of thermo-electricity, was discovered by Seebeck in 1822. In making experiments on the Volta contact force he found that if in a complete metallic circuit there were junctions of dissimilar metals, and if these junctions were at different temperatures, then generally a steady current flowed in the circuit as long as the differences of the tem-

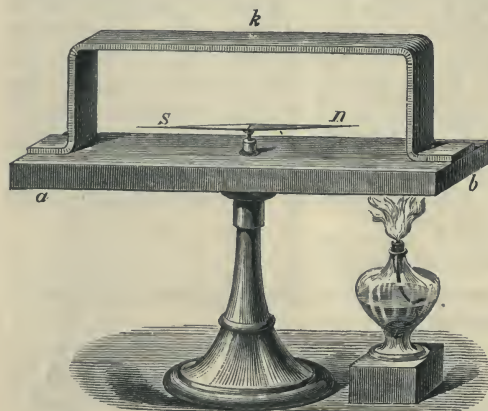

Fig. 159.—Seebeck's Thermo-Electric Apparatus.

peratures of the junctions were maintained. The apparatus used by Seebeck to demonstrate this effect for two metals only is shown in Fig. 159. A piece of copper  $k$ , bent in the shape seen in the figure, was placed on a block of bismuth  $a\ b$ , carrying a pivoted magnetic needle  $n\ s$ ; as soon as the equality of temperatures was altered by either heating or cooling one of the junctions of the two metals, the needle indicated a current which continued to flow as long as the

difference of temperature was maintained at the junctions. The movement of the needle indicated the direction in which the current flowed. If, for instance, the north junction  $b$  were heated, the  $n$  pole moved eastwards, showing that at the heated junction the current flows from the bismuth to the copper, at the cold junction from the copper to the bismuth. The experiment may be extended to other metals, and Seebeck arranged a table of metals in thermo-electric order, as follows :

— Antimony	Silver	Tin
Arsenic	Platinum	Nickel
Iron	Copper	Cobalt
Zinc	Lead	+ Bismuth
Gold		

This order only holds good for temperatures within certain limits, and the structure of the metals, etc., must be taken into account. Bismuth and

antimony, being farthest from each other in the list, are best for the construction of thermo-electric combinations of pure metals.

The actual electromotive force of a thermo-electric couple is very small when compared with that of a voltaic cell. In the following table the metals are arranged in the reverse order to that just followed, and in the adjacent column is given the E. M. F. developed with each of these metals, and lead as a standard metal. The difference of temperature required to develop these E. M. F.'s is  $100^{\circ}$ , one of the junctions being cooled with melting ice ( $0^{\circ}$  C.) and the other heated with boiling water ( $100^{\circ}$  C.).

TABLE IV.—THERMO-ELECTRIC PROPERTIES OF THE METALS.

Metal.	Voltage when paired with Lead between $0^{\circ}$ and $100^{\circ}$ C.*
+ Bismuth ... ..	+ '00682 Volts.
Cobalt... ..	+ '00320 "
Nickel... ..	+ '00246 "
German Silver ... ..	+ '00148 "
Platinum (soft) ... ..	+ '00012 "
Aluminium ... ..	+ '00006 "
Tin ... ..	+ '00001 "
Lead ... ..	...
Copper ... ..	- '00017 "
Platinum (hard) ... ..	- '00022 "
Silver ... ..	- '00029 "
Gold ... ..	- '00033 "
Zinc ... ..	- '00035 "
Iron ... ..	- '00149 "
-Antimony ... ..	- '00463 "

\* The calculations are based upon Professor Tait's work.

In this table the positive sign indicates a current from the metal to lead across the *hot* junction. For any two metals in the table the E. M. F., under similar conditions of temperature, may be found by subtracting *algebraically* the voltage of the metal lowest down from that of the one above it. For a bismuth-antimony combination this gives  $\cdot 01145$  volt, or about  $\frac{1}{100}$ th of the E. M. F. of a Daniell cell.

Alloys may be used for thermo-electric purposes, and with some of these much larger E. M. F.'s are developed than with the pure metals. The position of various alloys in the thermo-electric series does not, moreover, follow the order which might be expected from the thermo-electric position of the metals whence they are formed.

The Peltier effect enables us to trace out the source from which the energy of a current flowing in a thermo-electric circuit is derived; for it is found that the direction of the current across the heated junction of the circuit is that which gives a cooling Peltier effect. We have therefore the current which is set up cooling the hot junction, whilst the external source of heat is supplying heat tending to keep up the

temperature. Some of the heat energy supplied is therefore transformed to electric current energy at the hot junction. At the cold junction, as a rule, the opposite effect takes place; the Peltier effect here is a heating effect, and some of the electric energy is thereby transformed back again to heat. Following a very general law, we see that the current flow tends to destroy the temperature difference which is necessary to maintain it.

We can now extend the experiment referred to in Fig. 158, and use the direction of flow of a current to indicate a difference of temperature at the junctions in a circuit of dissimilar metals. If, after the current from the battery has been maintained for some time, the key  $k$  is opened and the key  $k_1$  closed, the galvanometer  $G$  will indicate the existence of a current in the direction  $d e c G$  shown by the arrow, and

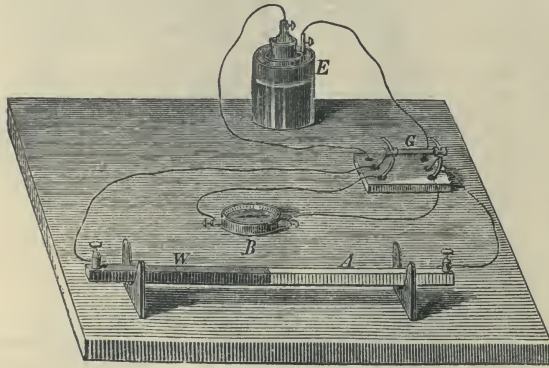

Fig. 160.—Peltier's Bar.

which therefore flows from antimony to bismuth through the junction  $e$ , or in the opposite direction to that in which the battery current passed through the junction. This indicates that the junction  $e$  is colder than the other thermo-electric junctions  $c$  and  $d$ , for the interposition in the circuit of the galvanometer

and other wires has no thermo-electric effect provided these wires are all at the same temperature.

Fig. 160 shows another apparatus used by Peltier for proving the existence of the Peltier effect. The free ends of the bismuth-antimony rod  $W A$  are connected by means of wires with the middle mercury cups of a Pohl's commutator  $G$ . The wires dipping into the first mercury cups are connected with a galvanometer, and the remaining wires with the cell  $E$ . If now we allow the current to pass from bismuth to antimony, the junction will be cooled. This causes a thermo-electrical difference in the rod  $W A$ , which is made manifest by the deflection of the needle when the commutator is reversed so as to cut out the cell and bring in the galvanometer. In the same manner the heating of the junction may be shown by sending the current in the opposite direction, that is, from antimony to bismuth.

*Thermo-electric Inversion.*—If a thermo-electric circuit of two metals, say copper and iron, be taken, and whilst one of the junctions is kept



at  $0^{\circ}\text{C}$ ., the temperature of the other junction be gradually raised, it will be found that the current generated gradually increases to a maximum, and then decreases until at a certain temperature of the hot junction the current ceases altogether. If the temperature of the hot junction be raised still higher, the current is again set up, but in the *opposite direction*. This phenomenon, known as *thermo-electric inversion*, was discovered by Cumming in 1823. Subsequent investigation has shown that when the current in such a circuit is a maximum, there is *no Peltier effect* at the hot junction. Above this temperature the Peltier effect is reversed. The temperature at which the Peltier effect disappears for any pair of metals or alloys is known as the *thermo-electric critical temperature* for those materials.

**The Thomson Effect.**—In Cumming's experiment, therefore, when the hot junction is at a temperature above the critical temperature, and before it has reached the temperature at which the current is reversed, the Peltier effect is such as to heat both the cold and the hot junction. *No heat energy, therefore, is being taken into the circuit at these junctions*, a result which appears to conflict with the fundamental law of the Conservation of Energy, for the current in flowing is giving out energy. Lord Kelvin (then Sir William Thomson) argued that energy must be absorbed somewhere, and since it was not absorbed at the junctions, it must be absorbed in the other parts of the circuit, that is, in the metals whose ends are at different temperatures.

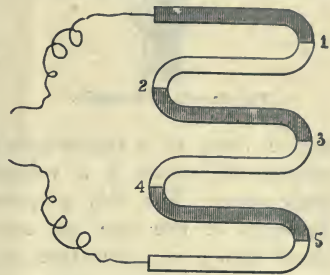

Fig. 161.—Thermo-Electric Battery.

By a series of masterly experiments, for the effect sought is a very small one, he proved that the mere passage of a current along an unequally heated bar of copper from the cold to the hot end caused the bar to be cooled, and that in iron the same result was produced by the passage of a current from the hot to the cold end. This phenomenon is known as the "Thomson Effect." In the experiments allowance had to be made for the usual heating due to the passage of the current through each metal.

**Thermopiles.**—Thermo-electric batteries, or thermopiles, can be built up of strips of two dissimilar metals placed alternately in the circuit as shown in Fig. 161, where the shaded bars are intended to represent one of the metals and the unshaded bars the other. As the junctions have to be alternately heated and cooled, care must be taken that the odd junctions 1, 3, 5, etc., are on one side, and the even junctions 2, 4, etc., on the other. If the former be heated and the latter cooled, a current will be produced on closing the circuit due to the thermo-electric E. M. F. generated by the arrangement.

To increase the E. M. F. of the pile, it is necessary either to increase the temperature difference or to increase the number of junctions. Fortunately the general conditions are such as to render compact arrangements of numerous junctions possible. One of these is shown in Fig. 162, in which all the even junctions are on one side of the pile and all the odd junctions on the other. Where the metals are not to be in contact, proper insulating spaces or materials are interposed. The two ends of the series are joined to the binding screws *y* and *x*, from which wires can be taken to the external circuit. In Melloni's experiments on radiant heat he used the pile shown in Fig. 163. Cones *c* could be placed on either or both ends of the pile to direct the radiant waves on to the thermo-electric junctions.

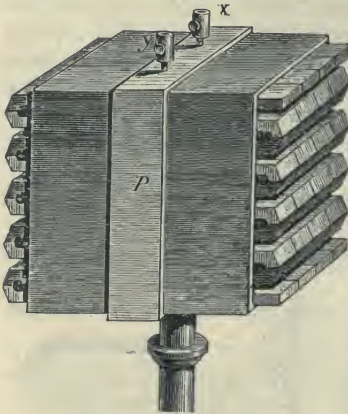

Fig. 162.—The Thermopile.

The circumstance that the electromotive force of a thermopile is proportional to moderate differences of temperature makes it a valuable and delicate instrument for measuring temperature. For this purpose the wires of the pile are connected with a very sensitive galvanometer. A very slight difference of temperature generates a current; and the strength of this current, which is proportional to the difference of temperature for a considerable range, is indicated by the deflection of the needle. Melloni found that  $\frac{1}{8000}$ th of a degree can be measured with this instrument, a minute difference which, of course, cannot be obtained with any ordinary thermometer.



Fig. 163.—Melloni's Thermopile.

More recently much more sensitive thermopile galvanometers, capable of detecting temperature differences of  $\frac{1}{1000000}$ th of a degree, have been constructed.\* The description of these, however,

\* The thermo-electric radio-micrometer of Professor Boys is capable of detecting a difference of temperature of less than one-millionth of a degree.

will be better understood when we have explained the principles of galvanometry.

For certain purposes, *e.g.* for ascertaining the comparative temperatures at any given line in the spectrum, thermopiles are used having the even and odd junctions arranged in straight lines. Another device is the thermo-electric needle, which consists of one couple, the junction of which is pointed. With it the condition as regards temperature of animal and vegetable textures can be investigated.



## CHAPTER IV.

*ELEMENTARY LAWS OF SIMPLE CONTINUOUS CURRENTS.*

## I.—OHM'S LAW OF CURRENT FLOW.

**Illustrations and Explanations.**—We have seen that by putting two different metals into a liquid we set up an electromotive force, which gives rise to an electric current if a closed circuit be provided. This electric current lasts as long as the E. M. F. is maintained, that is, as long as the chemical action lasts, and it flows from points of higher to points of lower potential. Let us consider again the simplest form of galvanic cell, namely, that consisting of a copper plate and a zinc plate in dilute sulphuric acid, the unimmersed ends of the plates being joined with a wire. Every similar arrangement is called a closed circuit. In our combination positive electricity moves from the unimmersed copper end to the unimmersed zinc end. We further know that the current is not restricted to the connecting wire, but extends to the plates dipped in the liquid and to the liquid itself. In the liquid positive electricity flows from the zinc to the copper. In the circuit, then, a current circulates passing from zinc to copper in the cell and from copper to zinc in the external wire. When, therefore, we speak of the *direction of the current*, we mean the direction of flow of positive electricity, or the direction of fall of potential in the outer wire.

To explain the laws of the current we shall return to the analogy of a flow of water. The water in the reservoirs A and B in Fig. 165 stands at different heights. As long as this difference of level is maintained, water from B will flow through the pipe R to A. If by means of a pump P the level in B be kept constant, a constant flow through R will also be maintained. Here, by means of the work expended on the pump, the level in the reservoir is kept constant, and in the corresponding case of the electrical current, by the conversion of chemical energy a constant difference of potential is maintained.

Through every cross section of the water circuit a certain quantity of water flows per second, and this quantity may be taken as the measure of the strength or magnitude of the current. Similarly, through every cross section of a conductor a certain quantity of electricity flows in a given time. That quantity of electricity which flows in one second through any one cross section of a conductor is called the strength or magnitude of

the current. If 10 gallons of water flow in every second into a system of vessels and pipes of any shape, whether simple or more complicated as shown in Fig. 164, and 10 gallons flow out again per second, it is evident

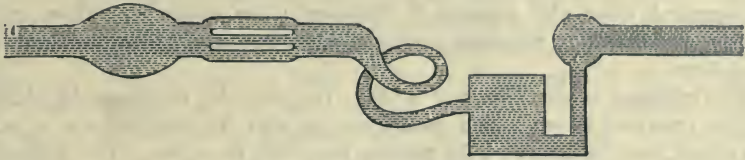

Fig. 164.—Flow of Water through Pipes.

that through every cross section of any vessel or pipe of the system 10 gallons of water pass every second. This follows from the fact that water is an incompressible liquid and must be practically of the same density throughout the system. The water moves slowly where the section is large and quickly where it is small, and thus the quantity of water that flows through any part of the system is independent of the cross section of that part. The same condition holds good for the electric current; if in a closed circuit a steady current circulates, the same amount of electricity will pass every cross section per second. Hence the following law: *The magnitude of a steady current in any circuit is equal in all parts of the circuit.*

Again, we shall increase the quantity of water flowing through the circuit in a given time by increasing the pressure producing the motion; that is to say, by increasing the difference of level of the reservoirs A and B (Fig. 165). Now, the pressure per square centimetre and the difference of level are both given by the same number in the c. g. s. system of units. Similarly, in electricity the differences of potential produced by the contact of metals and liquids, and the E. M. F. producing the current, may be measured by the same number, since differences of potential and electromotive forces are quantities of the same order, being both electric pressures.

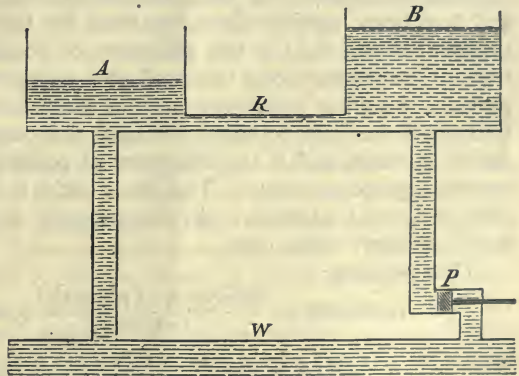

Fig. 165.—A Circuit of Water analogous to the Voltaic Circuit.

As the strength of the current in the water system is proportional to the

difference of level of the cisterns, or to the pressure exerted, so also in the electric circuit the strength of the current is proportional to the electromotive force or electric pressure produced by the battery or generator.

The quantity of water flowing through a pipe during a given time will be increased when the pressure is increased; the water then flows more quickly, and therefore a greater quantity must pass every cross section in a given time.

The pressure of the reservoir B (Fig. 165) can be increased by placing another reservoir above B, and connecting B with it; similarly the E. M. F. in a circuit may be increased by placing two cells in series. The difference of potentials in the cell determines the pressure or E. M. F., and therefore also the quantity of electricity flowing for any given time through any cross section of a circuit. If, therefore, we connect several cells we increase the electromotive force and increase the current; in other words, the intensity of the current increases with the E. M. F.

The magnitude or intensity of the current depends, however, upon something else. In the water circuit it depends on the connecting pipes; the wider the pipes the greater the flow, and the smaller the pipes the less the flow with the same pressure. Similarly the magnitude of the electric current depends on the connecting wires. It has been mentioned that different substances conduct electricity differently, and therefore the quantity of electricity passing per second from one point to another depends on the physical properties of the wire or conductor joining the two points, when a constant difference of potentials is maintained between them.

The law underlying the phenomena was discovered by G. S. Ohm, and has been verified since his time by thousands of experiments. It asserts that the ratio of the difference of potential between two points to the current passing along the conductor connecting them is a fixed quantity provided the other conditions, such as temperature, etc., remain unchanged. If the difference of potential be small, the current in the connecting conductor is small, and if the difference of potential be increased the current increases proportionately. This fixed ratio is called the *resistance of the conductor*, and is as much a physical property of the conductor as its weight, specific gravity, colour, etc.

Thus we have:

$$\text{resistance} = \frac{\text{difference of potential}}{\text{current}} \text{ (for part of a circuit) ;}$$

$$\text{or, resistance} = \frac{\text{E. M. F.}}{\text{current}} \text{ (for the whole circuit).}$$

This last equation may by transposition be written:

$$\text{current} = \frac{\text{E. M. F.}}{\text{resistance,}}$$

which is the form in which the law is most frequently stated. Although



electric resistance bears some analogy to mechanical frictional resistance, it is in reality a physical quantity of a very different kind, and the analogy must therefore not be pushed too far.

It will conduce to definiteness if we at once introduce the *names* of the practical units of E. M. F., current and resistance, leaving over their exact definition until we have developed the subject further. We have already (page 152) had occasion to refer to the practical unit of E. M. F. and of potential-difference as the **volt**. The corresponding practical unit of current is known as the **ampere**, and the practical unit of resistance is the **ohm**. It will be noticed that all these units are named after celebrated electricians. The equation just given is true whatever units are employed, provided they are consistent, but for the usual practical units it may be written :

$$\text{current in amperes} = \frac{\text{E. M. F. in volts}}{\text{resistance in ohms.}}$$

## II.—RESISTANCE OF WIRES.

We have, then, three factors which have to be considered in every electric circuit. Let us now see upon what circumstances these factors depend. Let us take a Daniell cell having a certain length of copper wire and a galvanometer in circuit. The current will cause a deflection of the needle through a certain angle. If now we double the length of copper wire, we shall find that the deflection is at once diminished. As we lengthen our wire we obtain smaller and smaller deflections. If we take wires of different cross sections we again obtain different deflections; the deflection becomes larger the larger the cross section of the wire inserted; in other words, the thicker the wire the less the resistance. This holds good, not only for copper wire, but for every substance inserted in a circuit. Again, the material as well as the form has to be considered; if, for example, we take one metre of iron wire and one metre of silver wire of the same cross section, and try the same experiment, we find different deflections for each. The resistance of a unit cube of the material of the conductor is called the *specific resistance*. To give the specific resistance of different substances a unit has to be adopted; that is, the resistance of some substance or other must be taken as 1. If, for instance, we take the resistance of a unit cube of copper to be 1, we shall find the resistance of platinum 6.99, German silver 19.2, and so on.

It may, however, be remarked here that there is a method of measuring specific resistance known as the absolute method, which is independent of the resistance of any standard substance. This method is now almost universally employed.

The laws of the resistance of conductors may now be collected as follows :—

1. *The resistance of a conducting wire is proportional to its length.*
2. *The resistance of a conducting wire is inversely proportional to the area of its cross section.*
3. *The resistance of a conducting wire of given length and thickness depends upon the specific resistance of the material of which it is made.*

$$\text{Thus, resistance} = \frac{\text{specific resistance} \times \text{length}}{\text{area of cross section.}}$$

To ascertain the resistance of a piece of material of uniform cross section it is, therefore, necessary to know its length and sectional area, both of which can be ascertained by direct measurement. In addition, however, the specific resistance of the material must be known, and this can only be ascertained by an electrical measurement or by consulting tables embodying the results of such measurements. Tables of specific resistance will be given in a later section dealing with methods of measurement.

### III.—CONNECTING UP BATTERIES.

Two or more cells joined up in any way to work together are technically known as a *battery*. The laws with which we have familiarised ourselves enable us to connect single cells with each other, to form such batteries, in the most advantageous manner. There are several methods which may be followed ; the usual way, as shown in Fig. 166, is to connect the electro-negative metal of one cell with the electro-positive metal of the next cell, and so on. In this and the next three figures the zinc, or electro-positive plate, is represented by the broad shaded double line, whilst the copper, or the electro-negative plate, is represented by the narrow unshaded double line. The electro-positive plate has the negative pole of the cell attached to it, whilst the electro-negative plate has the positive pole attached to it. The arrangement of cells in Fig. 166 to form a battery is known as a “series” connection. The electrical current flows here in the fluid of the first cell, the lowest in the figure, from zinc to copper ; through the connecting wire to the zinc of the second cell, whence it flows to the copper of the second cell ; then to the third cell, and so on, until the last cell is reached, when it leaves the copper, flows through the external circuit, and back again to the zinc of the first cell. When the entire current flows through every member of the circuit, as in this arrangement, Ohm’s law becomes :

$$\text{Current} = \frac{\text{sum of all the E. M. F.'S}}{\text{sum of all the resistances.}}$$



Fig. 166.—Cells in Series.

The resistance consists of the resistance of the cells and the resistance of the external circuit. If  $c$  be the current,  $E$  the electromotive force of one cell,  $R$  the external resistance, and  $l$  the internal resistance of one cell, then for the value for the current with one cell we have :

$$c = \frac{E}{R + l}$$

If now we connect six cells as shown in our Fig. 166, we get :

$$c = \frac{6E}{R + 6l}$$

Suppose now that the external resistance is so small compared with the rest that it may be neglected without appreciable error, then

$$c = \frac{6E}{6l} ; \text{ or, } c = \frac{E}{l}$$

We obtain, then, for the current of the six cells in series, in this particular case, the same value as for one cell ; in other words : *When we use an outer circuit of very small resistance, the current is not increased by increasing the number of cells in series.*

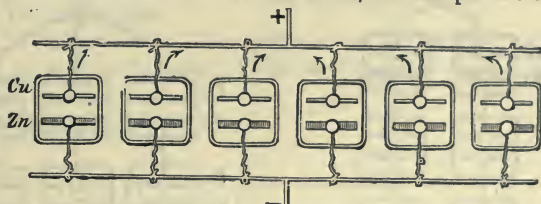

Fig. 167.—Cells in Parallel Connection.

Let us consider what happens when the opposite is the case, and the external resistance is very great compared with that of the battery. We can now neglect the resistance of the cells, and we get :

$$c = \frac{6E}{R} = 6 \frac{E}{R}$$

From this we see that by arranging our six cells in series we increase the current sixfold ; *it is advantageous, therefore, to arrange the cells in series when the external resistance is considerable.*

Cells may also be connected with each other as shown in Fig. 167. Here all the copper plates are connected with one wire, and all the zinc plates with the other wire. Such a battery is equivalent to one cell with six times the original surface ; the E. M. F. is not increased, but the internal resistance is diminished to  $\frac{1}{6}$ th of the original resistance, as the current flows through a cross section six times as large. This arrangement is known as the connection of cells in *parallel*.

The current =  $\frac{\text{E. M. F. (of one cell)}}{\text{external resistance} + \frac{1}{6} \text{ internal resistance (of one cell)}} ;$

$$\text{or, } c = \frac{E}{R + \frac{1}{6}l}$$



Neglecting external resistance, we get :

$$c = \frac{E}{\frac{1}{6}l} = 6 \frac{E}{l}$$

Therefore when the external resistance is but slight, the current is increased by joining the cells in parallel. When, however, the external resistance is very large, the internal resistance may be neglected, and we get the following equation, which is the same for one cell as for a number :

$$c = \frac{E}{R}$$

Hence the increase of cells in parallel arrangement does not increase the current when the external resistance is considerable.

The four equations which we have now obtained are important, as they enable us to arrange the cells so as to obtain the most favourable results

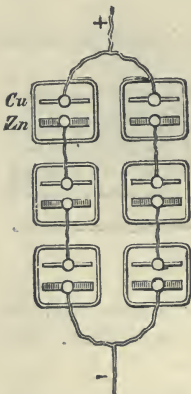

Fig. 168.—Cells in Double Circuit.

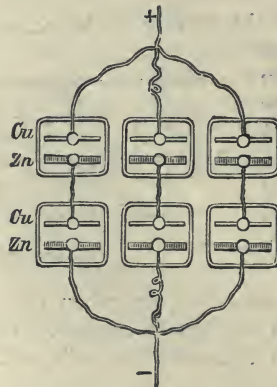

Fig. 169.—Cells in Triple Circuit.

under different conditions as regards the external circuit. Cells are arranged in series when the resistance of the external circuit is great, but in parallel when the resistance is small. Between the great and small resistance we may have intermediate conditions. In these

conditions we make use of both the parallel and series arrangements, the rule being to arrange the cells so that the internal resistance of the battery is most nearly equal to the external resistance. When this is done we obtain the maximum current from the cells through the given external resistance. Figs. 168 and 169 represent such mixed combinations of cells.

For Fig. 168 we should obtain the following formula :

$$\text{Current} = \frac{3E}{R + \frac{2}{3}l}$$

For Fig. 169 we get

$$\text{Current} = \frac{2E}{R + \frac{2}{3}l}$$

In obtaining these formulæ we have to remember that the E.M.F. of the battery is that of a single series row (*i.e.* 3E in Fig. 168 and 2E in Fig. 169), whilst the internal resistance is that of one of these single rows divided by the number of such rows.

IV.—COMPLEX CIRCUITS.

Up to the present we have discussed the arrangements of different cells with a single and simple external circuit; but the latter, too, may be divided into branches or loops. The simplest arrangement is obtained when all the parts of the circuit lie so that the total current, without dividing, can flow through them all. Fig. 170 represents such a circuit; here the separate parts  $a b$ ,  $b c$ , and  $c d$  of the circuit are so connected with each other that each part allows the whole current an undivided passage. The current here has to flow through one part after the other, and to pass through a resistance which is the sum of all the resistances of the separate parts in the circuit. The parts of a circuit may also be arranged in parallel as well as in series; Figs. 171 and 172 show such

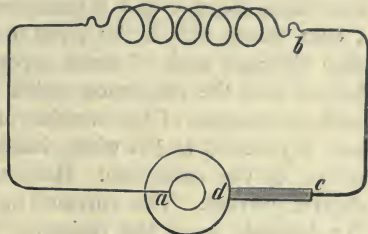

Fig. 170.—A Simple Circuit.

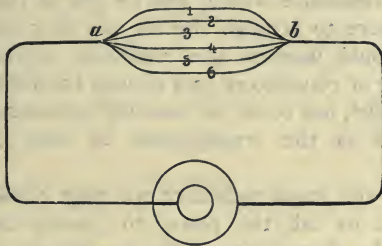

Fig. 171.—Divided Circuit.

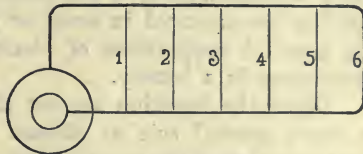

Fig. 172.—Divided Circuit.

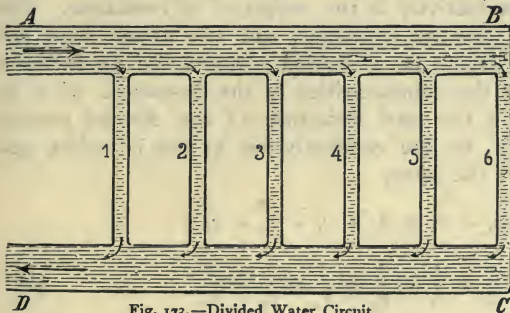

Fig. 173.—Divided Water Circuit.

arrangements. In Fig. 171 the wire  $a b$  divides into six branches. In Fig. 172 two wires run parallel with each other from the battery, having other wires joining them across the circuit. Such arrangements are called divided circuits; and the sum of the currents in the different branches of the

circuit must be equal to the whole current in the undivided conductor.

Let us compare the behaviour of the branch currents with water flowing through the system of pipes shown in Fig. 173. Water flows

through the pipes AB and CD in the direction indicated by the arrow-heads. The two pipes are connected with each other by a series of pipes 1 to 6, and water from AB is conducted through these six pipes to CD. The greatest amount of water will flow through that pipe which offers the least resistance, and the quantity of water that flows through the whole series of pipes must be equal to the quantity which flows through the cross sections at A and D (assuming that the same amount of water enters A that leaves D). If the pipes from 1 to 6 have all the same dimensions, then through each of these pipes equal quantities of water will flow; it follows that the resistance which the water from AB encounters diminishes with the increase of the number of pipes between AB and CD. The resistance is reduced to  $\frac{1}{6}$ th when, instead of communication by one pipe, there are six of the same size. Here the current of water is analogous to the electric current. The current in the circuit represented in Figs. 171 and 172 depends upon the resistance of the separate branches 1 to 6. The passage of the current is facilitated by increasing the number of branches in the circuit, consequently the total resistance of the entire circuit is thereby proportionally lessened. If the branches from 1 to 6 are of equal dimensions, they will form together a resistance which will be  $\frac{1}{6}$ th of that of a single branch. If, however, we were to arrange the six one after the other, as shown in Fig. 170, we should increase the resistance sixfold. This difference, then, in the behaviour of conductors in a circuit, according as they are arranged in series or parallel, has to be as carefully considered in practical applications of electricity as the arrangement of cells or generators in a battery.

When the branches are not all of the same resistance we may obtain a more general rule as follows. Let us call the power to convey the current either in the water circuit or the electric circuit the *conductivity* of the pipe or wire, so that conductivity is the reciprocal of resistance. The better the conductivity the less the resistance, and *vice versâ*. Now the following rule is evidently true. In a divided channel the conductivity of the whole is the sum of the conductivities of the branches. If  $c$  be the total conductivity, and  $R$  the total resistance of the divided portion of the circuit, and  $c_1, c_2$ , etc., be the conductivities of the branches, and  $r_1, r_2$ , etc., the resistances of the same,

$$\text{then } c = c_1 + c_2 + c_3 + c_4 + c_5 + c_6;$$

$$\text{hence } \frac{1}{R} = \frac{1}{r_1} + \frac{1}{r_2} + \frac{1}{r_3} + \frac{1}{r_4} + \frac{1}{r_5} + \frac{1}{r_6} \quad (a)$$

If there are only two branches :

$$\text{then } \frac{1}{R} = \frac{1}{r_1} + \frac{1}{r_2}; \text{ or } R = \frac{r_1 r_2}{r_1 + r_2}$$



Or, in words, *The joint resistance of a divided circuit of two conductors is equal to the product of the two separate resistances divided by their sum.* This rule, however, only applies to *two* branches; when there are more than two equation (a) must be used. The branch of a divided circuit which is added to reduce the current in the other branch is technically called a *shunt*.

## CHAPTER V.

*THE CHEMICAL EFFECT OF THE CURRENT.*

## I.—FUNDAMENTAL PHENOMENA.

IN summarising the chief effects of continuous electric currents on page 144 we have described the chemical effect thus: "If the conductor be a liquid which is a chemical compound of a certain class called **electrolytes** the liquid will be decomposed at the places where the current enters and leaves it." We have now to deal with the quantitative laws of the action, laws which in the main are beautifully simple, though complicated by external causes in minor details.

**Historical Notes.**—Päts van Trostwyk (1789) pointed out that an electric discharge was capable of decomposing water; to show this he used gold wires, which he allowed to dip in water, connecting one of them with the inner, and another with the outer coating of a Leyden jar, and passing the discharge through the water. The gas bubbles collected proved to consist of oxygen and hydrogen gas. Nicholson and Carlisle (1800) dipped a copper wire which was connected with one of the poles of a voltaic pile into a drop of water, which happened to be on the plate connected with the other pole; gas bubbles appeared, and the drop of water became smaller and smaller. This experiment was repeated in a somewhat different manner, the brass wires from a pile being brought under a tube filled with water and closed at the top. Gas bubbles were produced by the wire in connection with the negative pole of the pile, and the water was observed to diminish gradually. At the positive wire, on the contrary, no gas came off, but the metal lost its metallic lustre, became dark, and finally crumbled away. The gas which had collected in the tube proved to be hydrogen; while on examining the black mass it was found that the constituents of brass, viz. copper and zinc, had become oxidised.

By electrolysis, Davy, early in the nineteenth century, first obtained potassium and sodium from their oxides. He heated potassium oxide in a platinum spoon till it melted, used the platinum spoon as a positive electrode, and put into the molten potassium oxide another platinum wire, which represented the negative electrode. At the negative electrode, metallic potassium was separated, and of course at once took fire, and at the positive electrode oxygen was given off. Davy also obtained

potassium by bringing slightly moistened potassium oxide between the electrodes.

Seebeck obtained potassium in the following manner: A piece of solid potassium oxide, in which a hole is made, is laid upon a platinum plate serving as a positive electrode. The hole in the potassium oxide is filled with mercury, and into it a platinum wire is brought, to serve as a negative electrode. As soon as the circuit is completed the separation commences at the negative electrode. Metallic potassium forms with the mercury a kind of amalgam, from which it is obtained pure after the mercury is driven off by distillation. Sodium, calcium, barium, and strontium may be obtained from their compounds in a similar manner.

The oxides of the heavier metals can be decomposed by the electric current only when they can be made to conduct electricity. Faraday decomposed protoxide of lead by first melting it and then passing a current through it. Lead separated out at the negative, and oxygen was given off at the positive electrode. The halogen compounds (salts of chlorine, bromine, and iodine) are similarly decomposed by the electric current; the products, however, act on metals, and it is therefore necessary to make the positive electrode at least of carbon. The simplest way to obtain chlorine, bromine, and iodine from their compounds is to have a carbon crucible, which is made the positive electrode; and an iron wire, which serves as the negative electrode. The wire is removed from time to time to scrape off the separated metal.

To obtain magnesium, Bunsen used a porcelain crucible, which was separated into two portions by a partition which did not quite reach to the bottom. The crucible had a lid with two holes in the centre of each portion to hold the electrodes, which consisted of pure carbon. The form given to the electrodes is shown in Fig. 174. To prevent the magnesium rising to the surface, where it would burn away (as it is lighter than chloride of magnesium), grooves are made in the electrodes to hold it and allow it to collect. For the electrolysis 10 or 12 Bunsen cells arranged in series were used.

**Nomenclature.**—It is to Faraday that we owe the establishment, in 1833, of the fundamental laws of the chemical effect of the current on a firm quantitative basis, and the obligation is increased by the concise nomenclature that he devised in connection with every part of the phenomena. He named the process *electric analysis*, or more briefly **electrolysis**, since from what we have said it is obvious that a compound may be analysed by the disintegrating action of the current. The compound to be decomposed is called the **electrolyte**, and the poles or plates by which the current enters and leaves the electrolyte he called the electric



Fig. 174. — Bunsen's Electrodes.



ways or **electrodes**. The positive electrode, or that by which the current enters, he called the **anode**, and the negative electrode, or that by which it leaves, the **kathode**. The products of electrolysis he called **ions** (*i.e. the things which travel*), that given off at the anode being called the **anion** and that at the kathode the **kathion**. The whole arrangement he called a *Volta-electrometer*, or more briefly a **Voltmeter**, in honour of Volta, whose discoveries form the starting point of the phenomena connected with the electric current.

It will be observed that the conditions for successful electrolysis are that the *conductor* should be a *liquid* and also a *chemical compound*. This excludes from the list all liquid or molten metals which are elements, and the further condition that it is to be an *electrolyte* excludes the metallic alloys through which the current flows as through solid conductors. Lastly, it should be noted that the evidences of chemical action are only to be found at "*the place where the current enters and leaves*" the electrolyte.

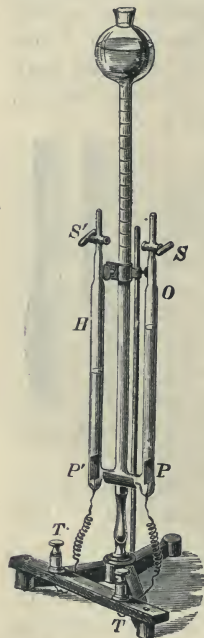

Fig. 175.—Hoffmann's Voltmeter.

The earliest observation made appears to have been that of the decomposition of water in the manner already described. A modern piece of apparatus for this experiment is shown in Fig. 175, in which the platinum electrodes  $P$  and  $P'$  are placed at the bottom of two upright tubes  $O$  and  $H$ , and are connected to the terminals  $T$  and  $T'$  by platinum wires, which are fused through the glass of the tubes. These tubes have glass stop-cocks  $S$  and  $S'$  at their upper ends, and at their lower ends are connected by a short glass tube, from the centre of which rises the large central tube which expands into a bulb at its upper end, which is open at the top. The three tubes can be filled with acidulated water from the central tube, the previously contained air being allowed to escape through the stop-cocks, which are afterwards closed. If it be so filled, and the terminal  $T$  be attached to the positive and  $T'$  to the negative pole of a suitable battery, bubbles of gas will be observed to rise from the plates  $P$  and  $P'$ , and finding their way to the top of the respective tubes, will displace the liquid, which will be driven into the open central tube. On examination it will be found that the gas rising from the anode  $P$  is oxygen ( $O$ ), and that rising from the kathode  $P'$  is hydrogen ( $H$ ). If the tubes are graduated, the latter will be found to occupy about twice the volume of the former. The proportion would be rigorously 2 to 1 were it not for the different solubilities of the two gases in water, oxygen being the more soluble of the two, and therefore appearing to be deficient in quantity.

If the water is strongly acidulated with  $\text{H}_2\text{SO}_4$ , the oxygen undergoes a further modification, forming ozone. Ozone is oxygen in a condensed condition. It is produced in comparatively large quantities by the action of electrical discharges through oxygen. The *silent* discharge is far more effective in bringing about this transformation than the spark discharge. According to Meidinger and Schonbein, the volume of O may be further reduced, under certain conditions, and another product formed during decomposition, viz.  $\text{H}_2\text{O}_2$  (hydrogen peroxide).  $\text{H}_2\text{O}_2$  diluted with water is an oxidising liquid, and is used for various purposes in the arts. Water containing a great percentage of  $\text{H}_2\text{SO}_4$  may lose as much as 0.6 per cent. of O during the formation of this compound.

Other classes of voltameters are those in which various metallic plates are used for electrodes, and solutions of the corresponding metals are the electrolytes. Thus a *copper voltameter* may be made by dipping a couple of copper plates into a solution of copper sulphate, and a *silver voltameter* by using silver electrodes, dipping into a solution of silver nitrate. When currents are passed through such voltameters, metal is plated out of the solution on to the kathode, which grows heavier, and an equal quantity of metal should be dissolved off the anode, which therefore grows lighter. This action is the foundation of the process of *electroplating*, which will be fully described in the technological section.

In such voltameters it should be noted that the apparent action at the anode is a *secondary* one. In the copper voltameter, for instance, the chemical decomposition effected by the current is given by the equation

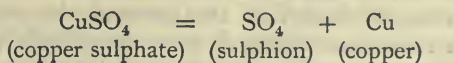

the sulphion being separated at the anode and the copper at the kathode. But the sulphion is separated in intimate contact with a copper plate, from which it immediately abstracts copper to form copper sulphate. .

In the water voltameter (Fig. 175) we had non-corrodible electrodes of platinum, and the gases formed according to the equation

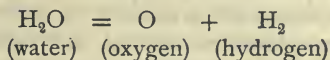

at once appear on the surfaces of the platinum. If the copper anode in a copper voltameter be replaced by a platinum or carbon anode, with which the sulphion cannot combine, the latter will at once act upon a molecule of water in the solution according to the equation

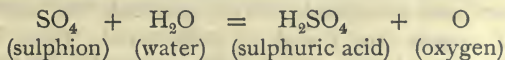

and oxygen will be given off at the anode. Some physicists assert that in the water voltameter the real electrolysis is that of the sulphuric acid

with which the water is acidulated, and that the oxygen is the product of a secondary action similar to the above.

In the historical notes (page 13) we have already referred to the decomposition of the halogen compounds (chlorides, bromides, and iodides) by the current. The fused salts may be used, but the chlorides of tin, lead, and manganese can be decomposed when in solution, though, as a rule, the solutions of compounds of chlorine, bromine, and iodine have to be very concentrated.

## II.—LAWS OF ELECTROLYSIS.

Faraday, to whom, as has been already remarked, we owe the foundations of quantitative knowledge regarding electrolysis, sums up the results of his experiments in the following general statement, which includes, either explicitly or implicitly, the various laws:—“*For a constant quantity of electricity, whatever the decomposing conductor may be, whether water, saline solutions, acids, fused bodies, etc., the amount of electro-chemical action is also a constant quantity, i.e. would always be equivalent to a standard chemical effect founded upon ordinary chemical affinity.*”\*

Before giving the formal laws involved in this statement, a few preliminary observations are necessary. Modern chemistry assigns to each of the elements or bodies which it cannot further decompose, not only a symbol for the sake of brevity, but also a number known as the “combining weight” or the “atomic weight.” These numbers are supposed to represent the relative weights of the elementary atoms, and are founded upon the experimental facts that the elements, in combining with one another to form compound bodies, do so in the definite proportions which are represented by these numbers or are multiples of them. Thus chlorine and potassium, in combining to form potassium chloride, do not combine in any haphazard way, but always in the definite proportion of 35.5 parts of chlorine to 39 parts of potassium, and if one of the ingredients present is in excess of this proportion, the quantity in excess remains uncombined. Similarly, water is always formed of 2 parts by weight of hydrogen combined with 16 parts by weight of oxygen.

The various elements, however, are not all “equivalent” in their combining power. Thus, whilst hydrogen always combines with chlorine, bromine, or iodine in the ratio of the atomic weights, when it combines with oxygen or sulphur two atoms of hydrogen are required for the one atom of oxygen or sulphur. In combining with nitrogen, three atoms of hydrogen are required for one of nitrogen, and with carbon four atoms of hydrogen for one of carbon. Thus, although the *atomic weights* of hydrogen and oxygen are 1 and 16 respectively, these bodies do not combine in this proportion, but in the proportion of 2 to 16. The atomic

\* Faraday's “Experimental Researches,” Series V., par. 505 (June, 1833).



weights corrected for these differences in combining value are known as the *chemical equivalents*. These are the numbers given in the second columns of the tables on pages 152 and 153, and used for calculating the electric pressures from thermal data. The actual numbers given are the weights of the various metals which combine with or are "equivalent" to 16 grammes of oxygen. They are also the weights of these metals referred to by Faraday as "founded upon ordinary chemical affinity," which enter into any electro-chemical action in which 16 grammes of oxygen play a part.

The next expression in the general statement which requires explanation is the "constant quantity of electricity." The statement affirms that a definite amount of electro-chemical action is always produced, when the necessary conditions are satisfied, by a constant quantity of electricity. According to this a convenient unit for measuring "quantities of electricity" would be the quantity required to produce a standard amount of electro-chemical action, such as the decomposition of 18 grammes of water (18 being the above-named chemical equivalent for water), or the equivalent weight of any other electrolyte. Having thus fixed our unit quantity of electricity, the unit current would be that current which conveyed the unit quantity per second, since one second is our unit of time in electrical measurements. The case is similar to that which would arise in water problems, in which, if one gallon had been selected for the unit quantity of water, a current of one gallon per second would be the unit current.

Unfortunately for the simplicity of electrolytic calculations, the magnitude of the unit current, as well as the unit of time, have been fixed by other considerations, and therefore, to avoid confusion in other directions, the unit quantity of electricity must conform to these units. The unit current of one ampere must convey unit quantity per second, and this unit quantity has been called the **coulomb**. It can, of course, be defined electrolytically by the amount of electro-chemical action it can produce in some standard electrolyte. The definition is as follows:—

**Definition of Unit Quantity of Electricity.**—*One coulomb is that quantity of electricity which, passing in a definite direction through a silver voltmeter,\* deposits 0.001118 of a gramme of silver.*

From this we can derive a definition of the ampere, which is, in fact, the definition adopted by the Board of Trade in dealing with electrical units:—

**Definition of Unit Electric Current.**—*A current of one ampere is a STEADY current of one coulomb per second, which, when passed through a silver voltmeter,\* deposits silver at the rate of 0.001118 of a gramme per second.*

The weight of silver named in these definitions is known as the "*electro-chemical equivalent*" of silver. Unlike the ordinary chemical equivalents,

\* Described in Chapter IX.

which are mere *ratios*, it is a *definite* weight. Corresponding weights can be tabulated for the other elements; their ratios will be those of the chemical equivalents, but they will be the actual amount of the element (or *ion*) acted upon by the passage of one coulomb of electricity. These weights are given in the following table, in which for convenience the chemical equivalents are included. The elements printed in italics are electro-negative, and will appear at the anode of a voltameter; the others (the metals) are electro-positive, and will appear at the kathode.

TABLE V.—ELECTRO-CHEMICAL EQUIVALENTS.

Element.	Chemical Equivalent.	Electro-Chemical Equivalent.
Hydrogen	2	'00001038 gramme.
<i>Nitrogen*</i> ...	9'3	'0000481 "
<i>Oxygen</i> ...	16	'0000828 "
Aluminium	18	'0000932 "
Magnesium	24	'0001242 "
Calcium	40	'0002070 "
Sodium	46	'000238 "
Iron (ferrous)	56	'000289 "
" (ferric)	37'3	'000193 "
Cobalt	59	'000305 "
Nickel	59	'000305 "
Copper	63	'000326 "
Zinc	65'5	'000339 "
<i>Chlorine</i> ...	70'7	'000366 "
Potassium...	78	'000404 "
Tin	118	'000611 "
<i>Bromine</i> ...	159'5	'000825 "
Mercury (mercuric)	200	'00104 "
" (mercurous)	400	'00208 "
Lead	207	'00107 "
Silver	216	'001118 "
<i>Iodine</i> ...	253	'00130 "

\* The names printed in italics indicate non-metallic, or *electro-negative*, bodies.

With reference to this table and the remarks which precede it, it should be carefully noted that the amount of chemical action is independent of time and that time does not explicitly enter into the definition of the coulomb. In other words, a small current passing for a long time can, theoretically, produce as great an electrolytic effect as a large current of short duration.

We are now in a position to state Faraday's laws in greater detail and on the whole in a more convenient form:—

**Law I.**—The quantity of an *ion* liberated in a given time is proportional to the total quantity of electricity that has passed through the voltameter in that time.

**Law II.**—The quantity of an *ion* liberated in a voltameter is *proportional* to the electro-chemical equivalent of the *ion*.

**Law III.**—The quantity of an *ion* liberated is *equal* to the electro-

chemical equivalent of the *ion* multiplied by the total quantity of electricity that has passed through the voltameter.

To calculate the weight of any *ion* liberated in a voltameter we have, therefore, the equation :

$$w = zQ \quad (a)$$

Where  $Q$  = the quantity of electricity measured in coulombs,

$z$  = the electro-chemical equivalent of the ion,

$w$  = the weight liberated (in grammes).

If the quantity of electricity be due to the passage of a *steady* current of  $c$  amperes for a time of  $t$  seconds we have further :

$$Q = ct \quad (b)$$

$$\text{and from (a) and (b) } w = z ct \quad (c)$$

This last equation can be used either to calculate  $w$  if  $z$ ,  $c$ , and  $t$  be known, or to calculate  $c$  if  $w$ ,  $z$ , and  $t$  are the known quantities.

A remarkable point about these laws is that no mention is made of any details connected with the dimensions of the apparatus or the magnitude or voltage of the current. It is the possibility of omitting these details which has led to the electrolytic definition being adopted as the *practical* definition for the coulomb and the ampere which depends on it ; for Faraday's and subsequent work has shown that the details referred to may be varied within wide limits, though not absolutely with impunity.

Nor is there any mention made in the laws of the source from which the current is to be derived, and the fact that the source is immaterial is one of the strongest proofs that all currents of electricity, however generated, have absolutely identical properties.

### III.—THEORIES OF ELECTROLYSIS.

The beautiful simplicity of Faraday's laws has naturally led to the attention of philosophers being directed to them, in the hope that they may, when still further probed, reveal some of the secrets of nature regarding the ultimate constitution of matter and the nature of electricity itself. As steps in this direction, various theories of electrolysis have been advanced and experiments devised in support or in critical examination of them.

One of the earliest of these was the hypothesis of Grotthuss (1806), in which he assumed that the molecules in an electrolyte have their individual electro-positive and electro-negative atoms charged positively and negatively respectively. In an ordinary liquid, for instance in water, the molecules are arranged indifferently, like row 1 in Fig. 176, with their positive and negative ends pointing in all directions. When the charged plates A and B connected to the  $+$  and  $-$  poles of a battery are inserted in the water, the molecules under the action of the laws of electrostatic



action turn as shown in row 2, so that all the hydrogen or shaded ends (+) are turned towards the (-) plate B and all the oxygen or unshaded ends (-) towards the (+) plate A. All along the row the electrical forces

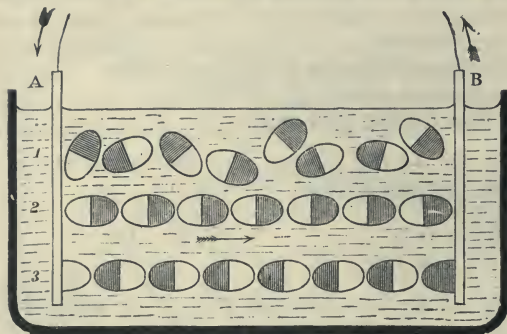

Fig. 176.—Explanation of Electrolysis.

are supposed to tear the molecules asunder, depositing H on B and O on A. The atoms in the middle of the liquid, however, recombine, for the hydrogen atoms in their journey towards B meet the oxygen atoms travelling in the opposite direction, and we get the state of affairs represented in row 3. The next step is to rotate once more the atoms into the

positions shown in row 2, and so on. In this way the theory accounts for the products only appearing at the electrodes and not in the body of the liquid.

Faraday (1833), adopting in the main Grotthuss's hypothesis, ascribes the cause of the successive decompositions and recompositions "to a modification by the electric current of the chemical affinities of the particles through or by which the current is passing, giving them the power of acting more forcibly in one direction than in another." Faraday went still further and asserted that conduction in electrolytes only takes place by these decompositions and recompositions by which the elementary charges of the atoms are carried with the latter towards the electrodes, this transfer of electricity being a true electric current.

Faraday's theory requires a sufficient E. M. F. to split, or, as we usually say, to dissociate, the molecules, this E. M. F. in the case of water not being less than 1.56 volts (*see* Table I., page 152), the electric pressure of hydrogen in an oxidising medium. But Faraday himself showed that a weak current could be maintained through a water voltameter for days by a single Daniell cell whose E. M. F. is only 1.08 volts. Helmholtz, however, showed that this current could not be produced if certain precautions were taken, and he attributed it to the presence of free hydrogen and oxygen dissolved in the water.

Clausius, applying a kinetic theory to the phenomena, assumed that in a liquid the individual molecules are always moving about with various velocities, which increase with rise of temperature, and that they are incessantly colliding with one another. Some of these collisions are sufficiently violent to smash the molecules into their constituent atoms, the latter carrying with them their electrical charges. These free atoms

as a rule find new partners sooner or later, but whilst in the free state the electro-positive atoms move towards the kathode, and the electro-negative ones towards the anode. Consequently, those which are close to the electrodes at the time of collision are separated out before they meet with fresh partners of the opposite kind, and we have the ions appearing at the electrodes. The theory is strongly supported by the fact that the conductivity of electrolytes increases with rise of temperature, which would also tend to increase the number and violence of the collisions.

More recently the subject has been minutely investigated by Hittorf, Van 't Hoff, and numerous other workers. Further experimental evidence has been adduced for the hypothesis that electric charges are carried through the electrolyte by the ions, and on certain assumptions as to the weight and nature of the ions, the charge on an atom of hydrogen or any univalent ion has been calculated to be  $8 \times 10^{-10}$  coulomb. The charge on divalent, trivalent, etc., ions will be 2, 3, etc., times this quantity.

A remarkable fact brought out by careful experiment is that some of the best-known electrolytes, if very pure, practically cease to conduct the current, and are therefore not electrolytes in this state. This has been proved true for water, sulphuric acid, and gaseous hydrochloric acid, yet the two latter, if dissolved in water, are good electrolytes of fairly high conductivity. Various hypotheses have been put forward to explain this. One is that the presence of the water, owing to its high specific inductive capacity, weakens the electrical attractions by which the oppositely charged ions of a molecule are held together, thus allowing dissociation to take place much more easily. In the pure materials it is assumed that there are no dissociated ions to carry the charges across, and thus set up a current. When water is added, dissociation commences and increases with the dilution, until in very dilute solution practically all the molecules are dissociated.

**Velocities of the Ions.**—Thus it would appear that the conductivity of an electrolyte depends upon the velocity with which the dissociated ions carry their charges through the liquid, and conversely from the specific conductivity the *ionic velocity* may be calculated. For instance, the combined velocity of the two ions in hydrochloric acid thus calculated is .00389 cm. per second, when the potential difference is one volt per centimetre. By careful measurements of the loss of HCl near the electrodes, the velocities of the two ions are found to be .00311 cm. per second for the hydrogen and .00078 cm. per second for the chlorine. These results have been further tested by direct experiment and found to be approximately correct.

**Electrons.**—Recent researches, especially in connection with electrical discharges through gases, have shown that the existence of bodies much

smaller than atoms is probable, and that these bodies always carry a negative charge. Professor J. J. Thomson calls these "corpuscles" or "electrons"; we shall return to the subject when considering gaseous discharges.

#### IV.—SECONDARY BATTERIES.

**Counter E. M. F. in Electrolysis.**—The following experiment is a fundamental and instructive one. Two Bunsen or bichromate cells (Fig. 177) are joined in circuit with the voltmeter *v* and the galvanometer *G*. In this circuit a three-way switch is inserted at *s* by means of which the wire *NS* can be connected either to the stud *a* or the stud *b*. The voltmeter *v* consists of two similar platinum plates *P* and *N* dipping into dilute sulphuric acid.

Let the tongue of the switch *s* be placed first on the stud *b*, so that there is a complete circuit

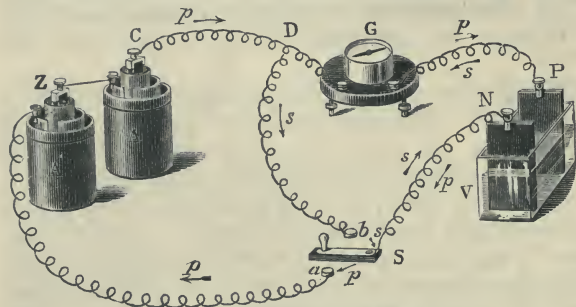

Fig. 177.—Experiment on Polarisation.

is a complete circuit *P G D b s N P* through the voltmeter and galvanometer.

No current will be indicated on the latter because the voltmeter, consisting of similar plates dipping into a liquid which acts on neither, does

not fulfil the conditions (*see* page 151) for the production of an E. M. F. Next place the tongue of *s* on the stud *a*; there is now a complete circuit *C D G P N s a z C*, which includes the battery, galvanometer, and voltmeter. A current will flow in this circuit and its existence will be indicated by the deflection of the galvanometer, which we shall suppose to be in a clockwise direction. If, after this current has been flowing some minutes, the switch *s* be suddenly moved over to the stud *b* so as to restore the first circuit, the galvanometer will immediately indicate by a counter-clockwise deflection a current in the opposite direction to the battery current. This current will gradually diminish and eventually disappear, but only after a considerable time.

Consider more closely what has happened. The plates in the voltmeter being precisely similar could not at first give rise to any E. M. F., and no current flowed, although a closed conducting circuit was provided. When the current from the battery was passed through the voltmeter, electrolysis occurred, oxygen gas being separated at the anode *P* and hydrogen at the kathode *N* in such quantities that the electrodes quickly became respectively



coated with these gases. In this state they were no longer two similar plates, but had become two *dissimilar* plates dipping into the acid. They were, in effect, a plate of hydrogen and a plate of oxygen, and therefore capable of sending a current through the galvanometer when the battery was removed by altering  $s$ .

Next observe that the current  $s$  was in the *opposite* direction through the voltameter to that of the current  $p$  from the battery, and that therefore the E. M. F. producing it must have been opposed to the E. M. F. of the battery when the latter was forcing a current through the voltameter. We have in fact, here the same thing occurring which we have referred to (page 159) as causing the *polarisation* in a voltaic cell. Under otherwise similar conditions polarisation will be the stronger the more completely the plates are covered with the gaseous film. From the beginning of the electrolysis it increases until the electrodes are perfectly coated, and then it remains of constant strength, as further evolution of gas will no longer have any effect. If the E. M. F. of the original current is weaker than that of the polarisation, the latter will not be able to attain its maximum strength, because if it did so a current would be generated opposite to the original current. Ohm's law for electric currents generated by a battery gives us the following equation :

$$\text{Current} = \frac{\text{E. M. F. of battery}}{\text{total resistance.}}$$

This law, however, only holds good as long as no liquids are inserted in the circuit ; if electrolytic liquids are part of the circuit we have

$$\text{Current} = \frac{\text{E. M. F. of battery} - \text{E. M. F. of polarisation}}{\text{total resistance.}}$$

Another way of regarding the fundamental experiment is of great practical importance. We have previously explained that one of our great sources of energy is the energy of chemical separation of materials which under suitable conditions can combine to form compound bodies. To separate the constituents of these compound bodies, work or energy must be spent upon them at least equivalent to the energy these constituents can yield up again when they re-combine. Now, when the battery was sending a current through the voltameter, it was spending some of its energy in decomposing the water and coating the electrodes with hydrogen and oxygen. This energy, stored up as the energy of chemical separation in the gases on the plates, is the energy available for producing a current when the battery is cut out and the independent circuit closed through the galvanometer.

We have therefore, in the experiment, energy stored up by the action of an electric current (usually called the *charging* current) in such a form that it can readily be used to generate another (or *discharging*) current. This is the principle made use of in the *secondary batteries* which are now so largely

used in heavy and other electrical work. The process at first sight may appear to consist in a storage of electricity. The electricity conducted into the voltameter from the primary cell *can apparently be got out again from the voltameter*. The storage, however, is not the same as in a Leyden jar or condenser, but is a conversion of electrical energy into chemical energy, which may be re-converted into electrical energy. The primary current separated hydrogen and oxygen from each other, and stored them on the electrodes; in the secondary cell oxygen and hydrogen unite again, the energy of chemical separation disappears, and electric energy again appears. Therefore, the secondary cell is not an apparatus for storing electricity, as electricity simply, but an apparatus by means of which electric energy is converted into chemical energy, in a convenient form to be turned back into electric energy. On this ground, therefore, the term electric accumulator, which is sometimes used, is not altogether an appropriate one for these secondary cells.

We have now to consider the best way to utilise the process for actual work. The simple water voltameter, *i.e.* two platinum plates in acidulated water, is not of much value, though, as we shall see presently, Grove made good use of it. Such a secondary cell would last only for a very short time; in other words, it is not capable of storing large quantities of electrical energy in the form of the chemical energy due to separation. The electrodes, however, may not only undergo physical changes, they may also be chemically changed by oxidation or reduction. When this is the case, and the electrodes are connected, we have a secondary cell that will furnish us with current as long as the modification of the electrode lasts. It is on this principle that the secondary cells in use at present have been constructed.

**History of Secondary Cells.**—Before we consider the secondary cells themselves, it will be useful to sketch their history briefly. Gautherot in 1802 observed that during electrolysis the platinum wires which served as electrodes became polarised, and that by the absorption of oxygen and hydrogen they became electrically different. By connecting the two electrodes he obtained a secondary current.

A short time after (1803) J. W. Ritter constructed the first secondary battery. Discs of the *same* metal, having moistened pasteboards between them, were arranged in the same manner as Volta's pile, and their poles were connected to the poles of a Volta's pile. When the current of Volta's pile was allowed to pass through the secondary battery for some time, the battery assumed the properties of a pile. The metal plate of the secondary battery, which was connected with the positive pole of Volta's pile, became a positive pole, and the plate connected with the negative pole became a negative pole. Hence through the closed circuit of the secondary battery a current flowed in the opposite direction to that of the primary current. Although Ritter was well aware of the importance of his

experiments, he did not follow them up at the time, for the simple reason that he had not the means.

**Grove's Gas Battery.**—In 1839 Grove carried the storage of energy by these methods much farther. The apparatus he used for the purpose is shown in Fig. 178. The glass tubes *O H* are open at the lower ends, and have platinum wires fused into the upper ends. These platinum wires terminate on the outside with platinum cups, and on the inside with platinum strips, coated with spongy platinum. The bottle and its tubes are filled with water slightly acidulated with sulphuric acid. Mercury is placed in the little platinum cups, and wires for connections are dipped into it.

As in the experiment already described (Fig. 177), a battery is arranged in the circuit in such a way that we can exclude the battery when we choose, but leave the circuit completed with the galvanometer included; then, starting with both tubes full of water, on making contact, the current will decompose the water, and at the same time deflect the needle. When the tubes become full of the gases we cut out the battery, and the needle of the galvanometer is at once deflected in the other direction, showing that the current produced by the gases is opposite to that which liberates them. The two tubes being perfectly similar in all other respects to each other, the gases only can be the cause of the current.



Fig. 178.—Grove's Gas Battery.

We may digress here for a moment to note that Grove's researches led to the discovery of *gas primary batteries*. The above arrangement, in fact, can be so used, for instead of charging it with gas by electrolysis the tubes may be filled with the proper gases produced by any of the usual chemical methods and forced into them. The cell will then act as a primary cell as long as the gaseous supply lasts. Grove examined a great number of gases and vapours, and found that gases can be arranged with the metals in a series, graduated according to the difference of potential or E. M. F. they will produce. When, as with metals, we commence with electropositive substances first, we get the following table:

+ 1 Metals which decompose water.	7 Ether.	13 Carbonic acid.
2 Hydrogen.	8 Olefiant gas.	14 Nitric acid.
3 Carbonic oxide.	9 Ethereal oils.	15 Oxygen.
4 Phosphorus.	10 Camphor.	16 Peroxides.
5 Sulphur.	11 Metals which do not decompose water.	17 Iodine.
6 Alcohol.	12 Nitrogen.	18 Bromine.
		— 19 Chlorine.

If we take one of the metals that does not decompose water, and bring



it into contact with a gas lower down in the list, the metal becomes positively electrified, the electrification being the stronger the farther gas and metal stand from each other in the series.

Grove's battery has serious defects which prevent it being used for practical purposes. The chief of these are its inconvenient shape and the fact that the quantity of energy stored is not large. Both defects are due to the ultimate products of electrolysis being gases. For practical work these products should be solids and insoluble in the electrolyte, so that an adequate amount of energy may be stored in a moderate space and that the storage materials may remain on the electrodes.

The necessary materials to fulfil these conditions and the first practical method of utilising these materials were discovered after laborious and extensive investigations by Gaston Planté. In the *Comptes Rendus* of the French Academy appears one of the earlier formal accounts of Planté's labours,

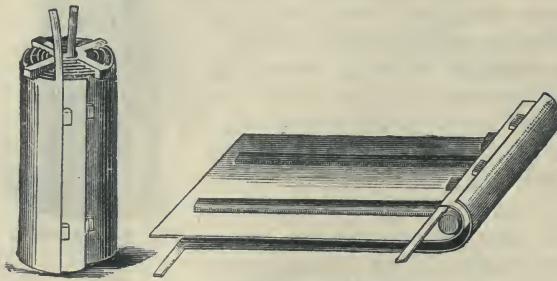

Fig. 179.—The Planté Lead Plates.

and from that time various notices of his work are to be found in the scientific publications. In 1879 he published a book entitled *Recherches sur l'Électricité*,\* which contains a full account of all that he has done. In an article written by Kareis (*Zeitschrift des*

*Wiener electrotechnischen Vereines*) he says : " When we remember that the electricians of the present day have endeavoured to make practical use of the energy stored up in the accumulators, it becomes difficult to believe that the originator did not entertain similar intentions. We are so accustomed to make practical use of every new discovery for our immediate and personal benefit, that we cannot help having a very high regard for men who are willing to leave the practical utilisation of their inventions to others. Such a man was Gaston Planté. Whoever enters his laboratory in the Rue des Tournelles finds that here science is neither the milch-cow nor the maid-of-all-work ; she is a companion that goes hand in hand with her master, revered by him on the one hand, and aiding him in all his endeavours on the other."

**Planté's Cell.**—The principle which Planté followed in the construction of his secondary cell is simply the chemical formation of the electrodes by means of a current. Numerous experiments proved that the best metal for this purpose, and the one most nearly fulfilling the conditions alluded to above, is lead. Two lead plates (Fig. 179), each 0.046 inch

\* Paris : A. Fourneau.

thick, with a projecting conducting strip, and insulated by means of india-rubber bands (0.2 inch), are laid upon each other and then rolled up into a cylinder, which is held in position by means of an ebonite cross. The cylinder is placed in a glass or guttapercha vessel containing diluted sulphuric acid (one part in ten). The lid of the vessel has several openings for the passage of the conducting wire and to allow the escape of gases. Two vertical metal bars *A A'* (Fig. 180) were frequently attached

to the lid, and were connected by a platinum wire *F*, which could be made red-hot by discharging the secondary cell. The bands *G* and *H* are in connection with the metal bands *M'* and *M*. *M'* is connected with *A* on the left, and *M* is connected with *A'* through the spring *R* on the right. When *B* is screwed down, *H* is also connected with *A'*. To charge the secondary cell two Bunsen cells are sufficient. The Bunsen cells are joined in circuit with the secondary cell, when *B* is screwed down, and the current of all the cells will pass through the wire *F*. Planté described the changes which occur when the cell is charged thus:—the electric current decomposes the water, and the oxygen separates out at the positive leaden plate, and the hydrogen at the negative leaden plate. The positive

leaden plate becomes oxidised and receives a brown coating of lead dioxide, whilst the negative leaden plate remains bright and receives only hydrogen gas. If now the two plates be connected by means of a wire, a current will circulate through the system, due to the production of a cell consisting of lead dioxide, lead, and diluted sulphuric acid. The current in this cell will have the opposite direction to the primary current, and will cause the lead oxide to be reconverted into metallic lead. When the reversion is at an end the current ceases, and the secondary cell is then said to be discharged.

The reaction of the sulphuric acid in the secondary element is of great importance. The sulphuric acid combines with the lead to form lead sulphate, a compound which is very insoluble, and which covers the leaden plates with a white layer, thus protecting the lead from further

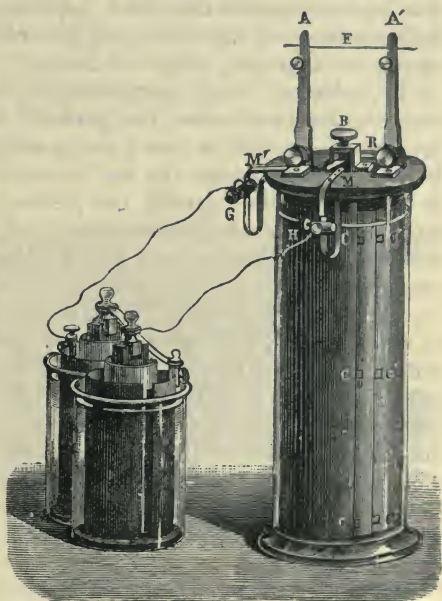

Fig. 180.—The Planté Cell.

corrosion. The current decomposes the lead sulphate, forming lead dioxide at the positive leaden plate, and lead in a spongy form at the negative leaden plate. The production of the spongy form of lead increases the surface, and consequently the effect of the plates. By repeating the process of charging and discharging the secondary cell the spongy mass will be increased through the action of the sulphuric acid, and, further, when the secondary cell is charged the upper layer of the lead dioxide will be reconverted into lead sulphate, which will prevent the further decomposition of the lead dioxide, and thus allow the cell to keep its charge for a greater length of time.

In order to charge completely a newly constructed Planté cell it is not sufficient to allow the primary current to pass through it for a considerable length of time; for as soon as the first layer of lead dioxide is formed it will protect the lead beneath it from the action of the oxygen. A short time after passing the primary current a brisk evolution of gas takes place, and if the secondary cell be discharged the oxidised lead will be again reduced, and the second electrode will become oxidised, thus causing both electrodes to have spongy surfaces. The primary current will now produce a greater amount of lead dioxide when allowed to pass through the secondary cell again in the original direction. It will be observed that the brown colour of the oxidised lead becomes lighter, until it appears almost white, when a charged secondary cell is left for some time in an unclosed circuit. The cause of this alteration is due to the action of the sulphuric acid, which turns some of the lead dioxide into white lead sulphate, which by mixing with the brown dioxide causes it to assume a lighter colour. At the next reduction the lead sulphate is also converted into lead, which adheres in grains on the surface of the plates, increasing the layer of material capable of being acted on by electrolysis.

According to Planté, a secondary cell made from lead plates should be formed thus: The primary current is allowed to pass through it for about a quarter of an hour; it is then discharged. The current is now passed through in the opposite direction a little longer; it is again discharged, and so on. When the time has been increased to two hours, it is left during the night and discharged the next day. It is then charged once more, and left for about eight days. After this somewhat lengthened process has been gone through once, the apparatus need only be charged when wanted.

After discharging a secondary cell, we find that, if we leave it for some time, it will again give a current, especially if the first discharge is very powerful. This is due to the too rapid electrolytic action of the first discharge current covering the plates with protecting layers, which put the active material below out of action for a time. On standing, these layers are dissipated more or less, and a further current can be obtained without recharging.



**Planté's Original Batteries.**—Fig. 181 represents a battery, consisting of twenty cells, arranged to be joined up either in series or in parallel. The commutator consists of the wooden beam *c c*, flanked with copper bands which are pressed by the springs *r r*. The front springs are connected with all the poles of one kind, and the back springs with all the opposite poles, the springs at the back being moved one place to the left so that the front (+) spring of one cell is opposite the back (−) spring of the next. In this position of the commutator the cells are joined parallel, thus representing one cell having plates of large dimensions. The copper bands are connected with clamps *G G* for charging and discharging purposes. When the commutator is turned through  $90^\circ$  by means of the knob *B*, the metal pins fastened to the beam *c c* will come under springs *r r*, so that the opposite metal springs are connected with each other, and the cells are joined in series. The wires from the poles of the battery, when so joined up, are connected with the clamps *T T*, between which there will be a pressure of over 40 volts.

By this arrangement of Planté's it is possible to charge the battery with the current from

two Bunsen or bichromate cells (E. M. F. about 4 volts), and discharge at the full pressure of the 20 cells placed in series, each cell having an E. M. F. of about 2.15 volts and a very low internal resistance.

There is, of course, no gain of energy by thus charging in parallel and discharging in series. The only advantage is that a current at a low pressure can be used for charging, whilst in discharging a current at a much higher pressure can be obtained. The arrangement is what in much more recent times would be called a "step-up" transformer, the "step-up" in Fig. 181 being from about 2.5 volts to 43 or 45 volts, with more than a corresponding decrease in the current.

This method of charging secondary batteries by placing single cells in parallel has now been abandoned, but in Planté's hands it yielded some striking results which are worthy of notice. A large battery of 200 cells is shown in Fig. 182, in which the charging Bunsens appear on the window-sill outside the room, where their noxious fumes will not cause trouble. The arrangements for charging with the 4-volt battery, and discharging at over 400 volts, can easily be traced. With this battery he produced

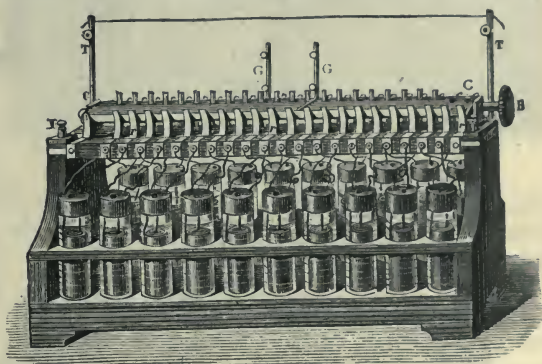

Fig. 181.—The Planté Battery (20 cells).

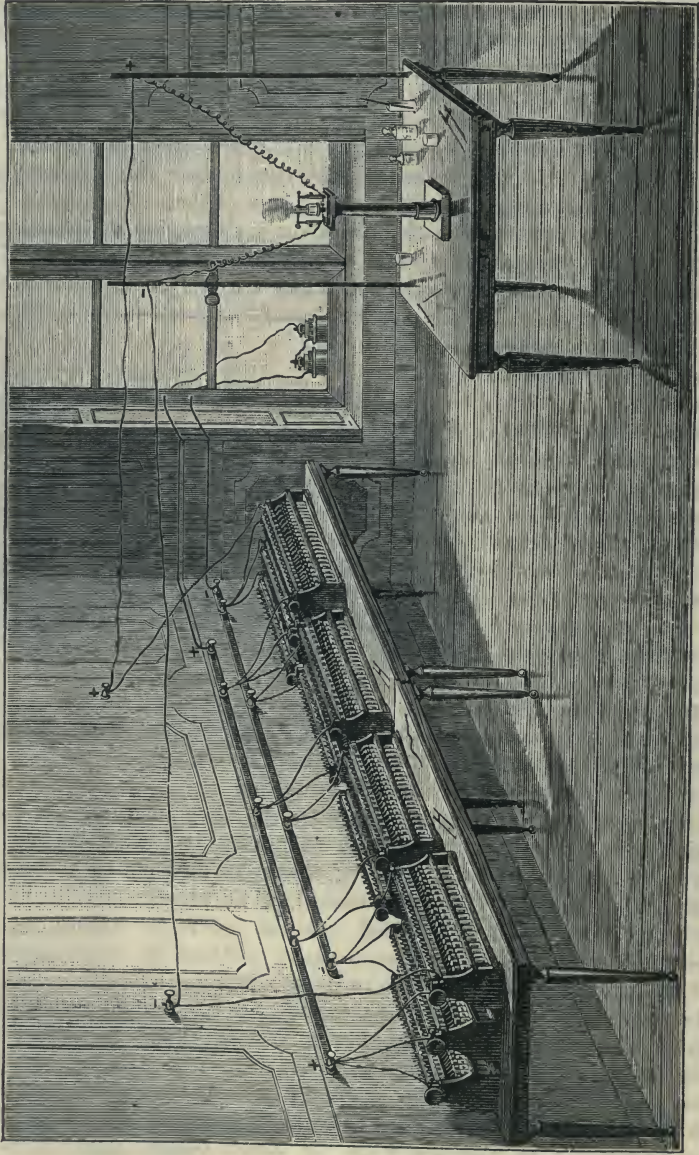

Fig. 182.—Large Planted Battery.



a phenomenon similar to that of ball lightning (Fig. 183). The negative electrode was immersed in a vessel containing salt water or acidulated water, and the positive was made to approach the liquid; when a certain distance was reached a luminous ball of vapour was formed, spinning quickly round, and becoming gradually flattened. This phenomenon was accompanied with a considerable noise. By using a large number of cells, and by allowing the negative electrode to dip into a vessel containing salt water, and bringing the positive electrode near it, Planté obtained a sheaf of glowing balls. The phenomenon produced, which is represented in Fig. 184, was compared to the formation of breakers by a spring tide. Planté's largest battery consisted of no fewer than 800 cells joined up in the manner described.

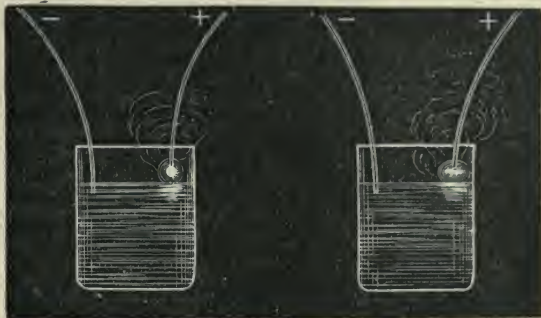

Fig. 183.—Experiment with Large Planté Battery.

The great drawback of the original Planté battery was the time taken

to form the cells, and, moreover, when these cells attained their most perfect condition, that is, when the whole of the lead on the positive plate was peroxidised, the cell very quickly fell to pieces. The attention of inventors was therefore directed to shortening the duration of formation, but little success attended their efforts until M. Camille Faure, in 1881, introduced the idea of

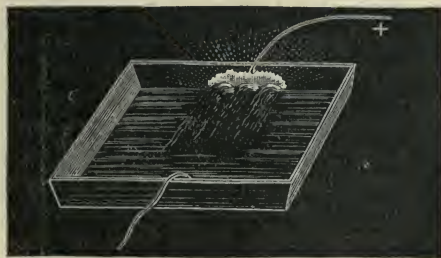

Fig. 184.—Experiment with Larger Battery.

starting the process with lead oxides produced by ordinary chemical methods, instead of beginning with plates of metallic lead and carrying through the oxidation electrolytically.

**Faure's cell**, as originally devised, consists of two leaden plates, one 24 inches long by 0.04 inch thick and the other 16 inches long by 0.02 inch thick. Both plates before being rolled up in the Planté fashion were coated with red oxide of lead (minium,  $Pb_3O_4$ ), made into a paste by diluted sulphuric acid. The large plate was loaded with 2 lb., the small plate with 1 lb. of the paste. The minium was then covered with parchment,



and the whole covered over with felt. It was placed in a cylindrical leaden vessel, having its inside coated with minium and felt. Such a cell weighed 19 lb. without the liquid. The form which Reynier gave to the Faure cell is shown in Fig. 185. The leaden vessel was replaced by a glass cylinder, and the felt by a texture which is not destroyed so quickly. As soon as the plates coated with minium were immersed in the diluted sulphuric acid, the minium was converted into lead dioxide and lead sulphate. The current had now only to complete the formation of lead dioxide on the one plate, and to reduce the compounds of lead on the other. According to Uppenborn, a Faure cell of this type had an E. M. F. of two volts and weighed 55 lb. With three Siemens' machines (model D<sub>2</sub>) 150 cells were charged in ten hours; if left unused they lost 1.5 to 2 per cent. per day.

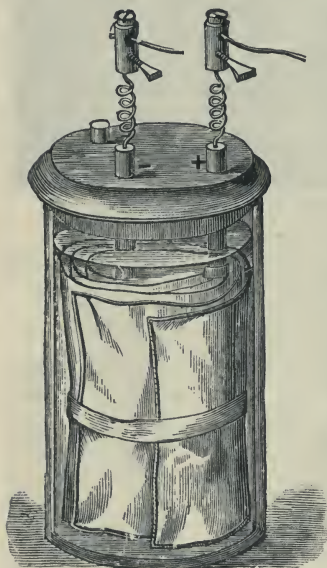

Fig. 185.—The Faure Cell.

On the first action of the charging current the sulphate of lead on one plate is reduced to a sponge of metallic lead, while that on the other is oxidised into peroxide. This is the only difference between the "secondary battery" of Planté and the "storage battery" of Faure. Both operate on the same principle and in the same way, with probably some considerable improvement in capacity in the Faure arrangement. Both batteries were frequently made in the form of numerous flat plates covered with some woven fabric, and packed near together in a rectangular box filled with dilute acid. The sole novelty in the Faure device was in the use of the paste of decomposable substance, by which a thick layer of active material can readily

be obtained on both plates of the battery. The Faure cells, as they were constructed for industrial use, were rectangular in shape, and were arranged in rectangular boxes of wood impregnated and heavily coated with an asphalt varnish, which enabled them to withstand the action of the acid solution which filled them. The weight of a single cell of such a battery was about 90 lb. to 100 lb.

The character of the actions, chemical and electrical, which go on in the secondary battery, and also the reasons for the losses experienced in it, were very fully developed in a paper on "The Chemistry of the Planté and Faure Accumulators," by J. H. Gladstone and Alfred Tribe, in *Nature* of January 5th and March 16th, 1882. The main sources of loss there shown are, first, local action between the negative lead plate and the peroxide

of lead deposited upon it; and second, the resistance of the oxide and sulphate to the passage of the current, by reason of which energy is lost by being converted into useless heat in the battery both at charging and discharging.

**Modern Secondary Cells.**—The form of secondary cell developed by Planté and Faure was found to have serious defects when it was attempted to use it widely for either scientific or practical purposes, and a great amount of experimental work was required before a cell was evolved which conformed approximately to the conditions which should be satisfied by a good working cell. Many of these conditions and the improvements made to satisfy them belong more strictly to the technological section of this book, but one or two are of more general interest, as is also the form which has been adopted for those cells which are most widely used.

Flexible plates rolled up as shown in Fig. 185, and which were copied by Faure from Planté, had soon to be abandoned when the cells began to be used for industrial purposes, for it was found to be impossible with such cells to prevent internal short circuiting. This trouble was aggravated by the difficulty of finding a separating material to replace the felt such as would resist the action of the acid for a lengthened period without rotting. Also the difficulty of efficient inspection was great in a cell of this form. These and other considerations have led to the almost universal adoption of stiff plane plates, covered in various ways with active material, for the constituents of a cell.

Modern secondary cells may be divided broadly into two classes—namely, (*a*) those which, following Planté's general method, form the active material on the lead backing which gives stiffness to the plate, and (*b*) the cells of the Faure type, in which the active material, partly prepared by previous chemical actions, is applied to the lead backing in the form of a paste. A reference to one example of each class will suffice for present purposes.

The first class may well be represented by the Epstein cell, which was formed by a modification of the Planté process. The plates before formation consisted of solid lead with deep grooves cut in it, as shown in Fig. 186, which represents on an enlarged scale a section of part of a finished positive plate. These grooved plates were first boiled for several hours in water containing 1 per cent. of nitric acid, or some other chemical that acts upon lead. During this boiling the exposed surface was bitten into by the chemical

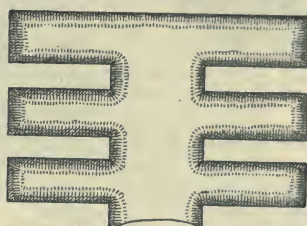

Fig. 186.—Section (Enlarged) of Part of Plate for Epstein Secondary Cell.

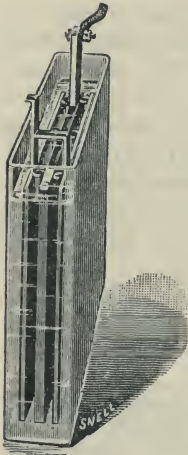

Fig. 187.—Epstein (Planté Type) Secondary Cell.

action, which left fine fissures all over the plate filled with oxide of lead. The formation was then completed by electrolysis, as in the original Planté process, except that the current was never reversed. The time of formation was only a few days, and the peroxide on the positives was found to be well fixed into and blended with the lead backing, as shown in Fig. 186, where the shaded parts are intended to represent the peroxide.

A complete cell containing one positive and two negative plates is represented by Fig. 187. The cell was 15 inches long, 17 inches high, and  $3\frac{1}{2}$  inches wide, and weighed about 86 lbs., the positive plate being 0.44 inch thick, and the negative 0.217 inch. Although containing only one positive plate, it could be discharged at the rate of 45 amperes, or on an emergency at 70 amperes, without permanent injury; at 45 amperes the rate is equivalent to about 21 amperes per square foot of the plane surface of the plate. The plates did not buckle, as the massive lead back equalised the current over the surface, and increased the conductivity of the cell. The distinguishing feature of the cell was its high storage capacity for its weight, which made it serviceable for traction purposes.

The distinguishing feature of the second class of cells formed after the Faure type is that the material which is to become eventually the peroxide of lead on the positive plates and the spongy lead on the negatives is applied to the grids or other backing in the shape of a paste of one of the intermediate oxides of lead. This oxide is then converted by electrolytic action into the required chemical state. In this way, as already

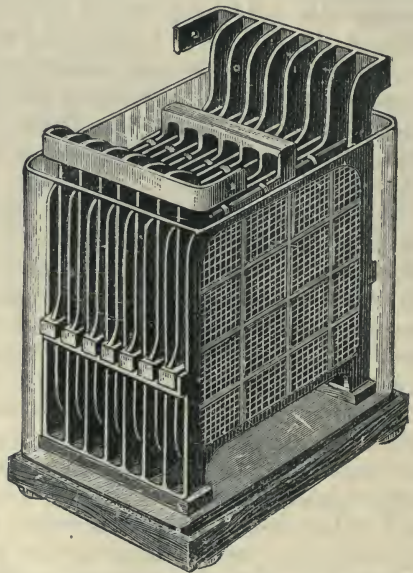

Fig. 188.—An Electric Power Storage Co.'s Cell.



explained, the time of formation of the cell, as compared with that of the original Planté cell, is materially shortened.

A 15-plate Electrical Power Storage (E.P.S.) cell of the "1881" L-type, as it is called, is shown in Fig. 188. For stationary batteries, except in the case of very large cells, the outer box is usually made of glass, which allows the condition of the plates to be inspected, to a moderate extent, from time to time without taking them out. The cell itself consists of eight negative or spongy lead plates, and seven positive or peroxide of lead plates. The employment of an extra negative plate enables the positives to be completely enclosed by negatives, a plan which has been found very effective in diminishing buckling. All the plates of the same name are joined in parallel by stout bands of lead into which lugs connected to the plates are burned.

In earlier cells these lugs were placed at one of the upper corners only of each plate, and, consequently, as the current entered and left by them alone the flow of current in the cell was not evenly distributed over the surface of the plates, being densest at the corners near the lugs. In Fig. 188, taking the eight negative plates first, it will be noticed that not only are they connected by a broad band of lead at the top, and which forms the negative terminal of the cell, but that there are in addition four other bands connecting the plates; two of these are at the bottom, one at the back and one at the front, resting on blocks of wood and supporting the weight of the plates, and two others about half-way up back and front. These last two are so shaped that they support blocks of wood, which in their turn support the positives by means of lugs projecting from the latter. The seven positive plates in their turn are connected first by the broad upper band in front, which forms the positive terminal of the cell, and also by a very massive band burnt into lugs projecting upwards from the centre of the top edge of each plate. In this manner the various plates of each part of the cell are put effectively in parallel, and the current evenly distributed, whilst at the same time the internal resistance is reduced.

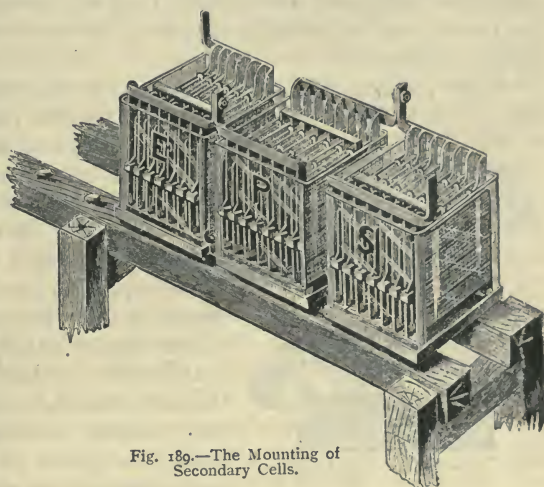

Fig. 189.—The Mounting of Secondary Cells.

The method of joining up cells of this and similar kinds to form a battery is illustrated in Fig. 189, where three such cells are shown connected in series. The cells stand in shallow wooden boxes containing a thin layer of sawdust to absorb any moisture. Each of these boxes is placed on three glass insulators resting on stout wooden trestles well varnished, or painted with a suitable paint, to make them as acid-proof as possible. The cells are turned alternately in opposite directions. The first cell has its negative terminal band at the front, and its positive one (usually painted red) at the back; the second cell has the negative at the back, and the positive at the front, and so on. It is thus possible to clamp tightly the positive of one cell to the negative of the next with very little resistance in the connections.

When the cells are being charged, and especially towards the end of the charge, gas is freely given off, and the bubbles rising to the surface burst, scattering the acid about in a kind of spray, which fills the atmosphere of the battery room. The atmosphere so charged is injurious if inhaled, and also attacks any metal surfaces exposed to it. All such surfaces should therefore be coated with an acid-proof paint, and for the same reason the wooden trestles should be similarly painted, as already noted above. It follows that no switches or contact-breakers, which necessarily expose bare surfaces of metal to the atmosphere, should be placed in the battery room. All such should be in an adjoining room, which,

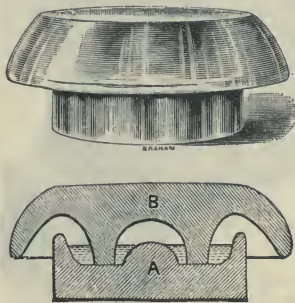

Fig. 190.—Glass and Oil Insulator.

to reduce the cost of and loss in the connecting conductors, should be as close as possible to the battery. To minimise the scattering of the spray curved sheets of glass, not shown in the figure, are placed over each cell, with their convex sides downwards.

The glass and oil insulators upon which the cells rest are shown in full and in section in Fig. 190. There is a shallow glass vessel A filled with insulating oil, over which is inverted a cap B, on which the cell rests. These insulators are designed on the same principle as telegraph insulators. The kind of leakage to be provided against is that known as surface leakage, the leaking current passing through conducting dirt films on the surface and not through the body of the material. An examination of the sectional figure will show that such leakage is provided against by the oil, the surface of which is protected against the formation of such conducting films by being covered over, and by its fluid action in absorbing any dirt that may rest upon it. The oil in itself is also a good insulator.

The further development of secondary batteries belongs to the later section of this work, where full details will be found of modern secondary cells, and of the part they play in electrical work at the present day. We shall, therefore, conclude this section with a brief summary of the methods available for charging such cells, leaving all technological details to be dealt with later.

**Charging of Secondary Cells.**—Voltaic cells, thermo-piles, or dynamo-electric machines may be used for this purpose. For all practical work the last named are to be preferred when available, but certain precautions must be taken if the cells be the only load on the dynamo. For smaller batteries, such as are required in laboratories, voltaic cells were often used in the early days of secondary batteries. To use cells such as Leclanché's would not have been advantageous, as the current of these cells would soon diminish by polarisation. Bunsen's cells, however, answered well. As the primary current causes an opposing E. M. F. in the secondary cells, it is necessary that the source of electricity furnishing the primary current should possess a higher E. M. F. than the secondary cell. For instance, in order to charge twenty cells of a secondary battery (E. M. F. = 2.15 volts each) joined in series, a source of current must be employed, the E. M. F. of which is more than 43 ( $2.15 \times 20$ ) volts. It is best to arrange the secondary cells of large batteries in series, and experience has shown that a large cell works better than several small cells containing the same total number of plates and joined up in parallel. In the latter case the currents may be unequally distributed, because of slight differences between the cells, an inequality which eventually damages the cells subjected to the heaviest currents. The currents to be used for charging depend entirely upon the total surface and character of the plates in each of the cells in series. The manufacturers will usually give information as to the best charging current for each size and type of cell, and this current should not be exceeded.

#### V.—ELECTRO-CHEMISTRY.

The applications of the chemical effect of the current, which are usually classified under the above heading, are both numerous and important, but they are most of them of a highly technical nature, and, therefore, will be more properly dealt with in the second portion of this book. We shall confine ourselves here to a few historical notes and an explanation of the elementary principles involved.

**Historical Notes.**—In 1805 Brugnatelli, Professor at the University of Pavia, showed that by means of the current from a Volta pile silver coins may be coated with a layer of gold; he made use of an ammoniacal solution of chloride of gold, in which the coins to be gilded were placed, being connected by means of a silver wire with the negative pole of the



pile, while the positive pole was in direct connection with the gold-bath. Many years later, and almost simultaneously, Jacobi, in Dorpat, and Spencer, in Liverpool, made their discovery of electrotyping. In February, 1837, Jacobi observed, in experiments made with a galvanic battery, that different layers of copper could easily be separated from the negative electrode; struck with the exactitude with which these copper layers had imitated the forms of the electrodes, he at once made use of his discovery for practical purposes. In 1838 Jacobi laid before the Academy of St. Petersburg copper-plates which were imitations of drawings engraved upon other copper-plates. The Emperor Nicholas allowed the inventor the necessary means for the further perfection of his process (1840). In the same year Spencer had obtained similar results. Elkington in England and De la Rive on the Continent were the first who introduced electroplating in commerce. In 1846 Boettger produced iron deposits, and in 1859 Jacquin discovered how to cover copper-plates with steel. In more recent times electrotyping in iron has been brought to high perfection at St. Petersburg by Klein, whose bas-reliefs exhibited during the Exhibition at Vienna, 1883, were very much admired. The firms of Christophle, Paris, and Elkington and Mason, Birmingham, have brought this branch of electrical manufacture to high perfection.

The deposition of metal at the kathode of an electrolytic bath has also been developed for the refining of copper on a large scale, and for separating metals from their ores. In some processes the electric current is merely auxiliary, and tends to make the process more certain and rapid; in others it is the chief factor in the process. The current is also used for the separation of metals from one another, as, for example, silver from lead.

In another direction numerous inventors have, more or less successfully, endeavoured to utilise the current to improve and cheapen the production of many materials usually manufactured by ordinary chemical methods, and of recent years this branch of electrical activity has increased by leaps and bounds. In the alkali manufacture, including the production of bleaching material, in various dyeing processes, especially with coal-tar dyes, in calico printing, in tanning, and in the rectification of alcohol, important results have been obtained. At one time the electric purification of sewage promised important benefits to the community at large, but it has more recently been superseded to a great extent by other methods.

Now that electric power is, in many places, so readily and cheaply available, electrolytic methods of analysis are becoming more and more a necessary part of the equipment of scientific chemists, and no modern chemical laboratory can be considered complete which does not contain facilities for *electro-chemical* analysis. In view of the fact that electrolysis is simply a shortened form of the term electric analysis, and that Faraday's laws are strictly quantitative, it is surprising that this method of analysis is

only now coming into use on an extensive scale. The explanation is probably to be found in the trouble and expense involved in the use of primary batteries for the generation of large currents, but now that dynamo currents are available the long-arrested development is taking place very rapidly.

There is still another important class of processes in which the chemical and heating effects are advantageously combined, but these will be more appropriately referred to after we have considered the laws of the heating effect.

**Electro-deposition.**—The fundamental laws governing the process are those which we have already given (page 196) as Faraday's laws of electrolysis. According to these a definite current passing for a certain time through a suitable solution will deposit on the kathode a perfectly definite weight of the metal of the solution, the weight deposited depending also on the "electro-chemical equivalent" of the metal. A table of these equivalents is given on page 196. Thus an ounce of copper would be deposited by a current of 10 amperes flowing for 145 minutes, or by a current of 1 ampere flowing for 1,450 minutes, or by 100 amperes flowing for 14.5 minutes. Similarly an ounce (avoirdupois) of silver will be deposited by a current of 10 amperes in 42.4 minutes, and so on for other metals.

But in actual practice, if it is desired to obtain a coherent deposit adhering to the kathode, several small details must be carefully attended to. Chief amongst these are the composition and strength of the electrolyte, the density of the current at the kathode (*i.e.* the number of amperes per square centimetre or per square inch of kathode surface), and the careful preparation, in which cleanliness plays a very important part, of the kathode surface to receive the deposit. Although, therefore, it is theoretically an easy matter to deposit metals electrolytically, the production of a *good* deposit for a specific purpose calls for the exercise of much technical skill and experience.

In practice the subject divides into two branches, namely: (1) *electroplating*, or the coating of objects with a thin layer of metal, and (2) *electrotyping*, or the production of metal copies, in exact facsimile, of various objects. Any source of continuous currents may be employed for these purposes, which only require currents of low pressure or E. M. F. In the early days, and even yet in small workshops, primary batteries of low resistance were extensively used; but at the present day in all large establishments dynamos are exclusively used as current generators for electro-deposition. The following two processes are of interest as illustrating the methods used in early days.

Fig. 191 represents an apparatus in which the source of electricity and depositing cell are in one. A glass cylinder, open at both ends, is supported as shown in the figure; bladder, parchment, or a similar substance is tied round the bottom of the cylinder. In the place of this inner glass vessel,

with its porous bottom, a diaphragm may be used, as in voltaic cells. In the inner vessel is a zinc plate, and the object to be plated is placed in the outer vessel and has a wire attached to it. This wire has covering it a non-conducting substance such as wax, gutta-percha, glass, etc. The two wires

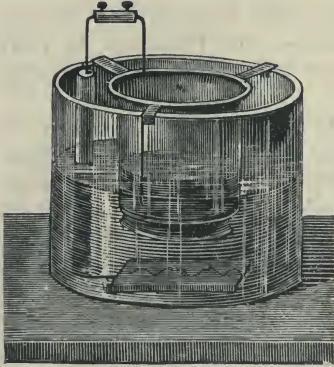

Fig. 191.—Electro-plating Apparatus.

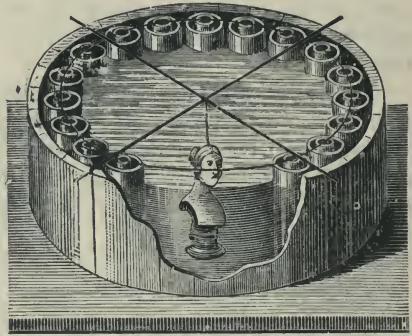

Fig. 192.—Electro-plating Apparatus.

are connected by means of a clamp. The inner vessel contains dilute sulphuric acid, the outer, if copper is to be separated out, a concentrated solution of copper sulphate. This apparatus, of course, can only be used for deposits on small objects, and then only for such objects as show no considerable cavities or protuberances, and require the deposit only on one side.

By means of the apparatus of Fig. 192, which is at the same time a bath and a battery, different objects may be coated with copper. A number of porous cells are placed along the sides of the outer vessel, which contains copper sulphate solution; each of these porous cells contains a zinc cylinder, surrounded by dilute sulphuric acid. A circular wire connects all the zincs, and is also connected with the cross wires which carry the objects.

The source of electricity and the deposition apparatus are, however, always separate when electro-plating is carried on upon a large scale. The electro-plating tank, as a rule, consists of some kind of earthenware that will withstand the effects of acid. It may, however, be made of wood, lined with gutta-percha, as shown in Fig. 193, or the wood may be lined with lead autonomously joined and covered on the inside with matchboarding. Two wires, parallel to each other, are fastened upon the edge. The outer wire frame, which lies higher than the inner, carries the positive clamp, while to the inner and lower wire the negative clamp of the bath is fastened. The metal anodes—silver plates, for instance—are hung at a distance of one to two feet from each other; the cross-bars to which they are fastened rest



upon the outer wire frame ; shorter cross-bars, from which the objects to be silver-plated are suspended to act as kathodes, are placed between the silver plates.

**Electrotyping.**—This title is applied to all those processes of electro-deposition in which the object is to produce a coating of metal sufficiently strong to be removed from the electrode to form an independent object. In the printing trades the process is very widely used for the production of copies of the type as set up by the compositor, and these copies properly mounted are used for the actual printing, thus setting free the more expensive type for further use, as well as saving the face of the type from becoming worn away by the work of printing. In this function, however, electrotyping has a powerful competitor in stereotyping, in which the copy for the printing press is taken mechanically in a metal of low fusing point. Not only, however, may the type of a book or other printed matter be copied electrolytically, but also the engravings and plates, and in this direction copper deposition is extensively employed, the original wood, steel, or other engravings being thus preserved from the rough usage of the printing press, and retaining their original sharpness and clearness even after tens of thousands of copies have been produced.

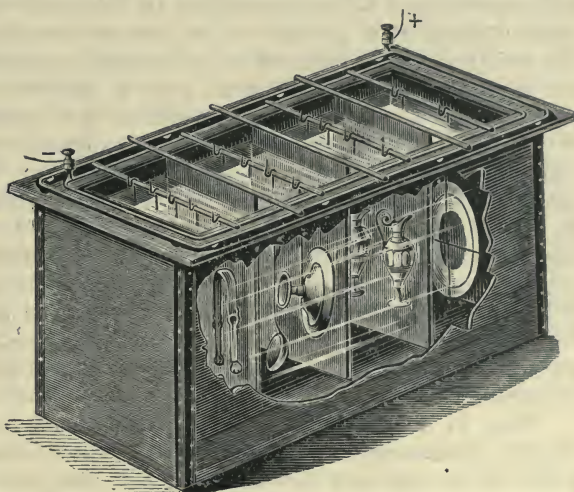

Fig. 193.—Electro-plating Bath.

In the process of electrotyping for printing purposes, it must be remembered that a facsimile copy of the type or the engraved printing block is required. If, however, the copper were deposited on the type or block, the shell of deposited metal when removed would be a negative of the type, etc., on which it had been deposited, and could not, therefore, be used for printing, for all the parts on the original which were raised would be sunk on the copy, and the sunk parts would be raised. If used for printing, the blacks would be white and the whites black. It is, therefore, necessary to interpose an intermediate stage, which consists in taking a mould or matrix in sufficiently soft, but not too soft, material, which will

be a negative of the original. Any metal electrolytically deposited on the mould will, when separated, be a negative of it, and therefore a positive copy of the original from which the mould was taken. The materials used for the mould are gutta-percha, stiff wax, plaster-of-Paris; etc., and sometimes alloys of low melting point. The former of these materials are non-conductors of electricity, and before a deposit can be taken on them, their surfaces have to be made conductive with blacklead, or metallic powder, or other suitable material. The technical details of these processes will be referred to later.

Another object of electrotyping is the production of *coins, medals, busts, statues, and works of art* generally. Here, again, if the electrotype is to be a positive copy of the original, an intermediate negative or mould must be prepared, and where the objects to be copied are complicated, great ingenuity and skill is required to produce a satisfactory result. When the object is much undercut or has irregular cavities, the mould must be taken with some pliable material, such as gelatine, as plaster-of-Paris or stiff material would be broken in separating the mould from the object. For large objects the cast or mould has to be taken in sections. Natural objects, such as leaves, small plants, insects, etc., can also be faithfully copied, with all their minute details, by electro-deposition.

**Other Applications.**—The more important of these have been already summarised, and it is almost impossible to explain the varied processes in general terms without going into the technical details which more properly belong to subsequent pages. It may, however, be explained that whereas in electro-deposition the action at the kathode is the one utilised, in general electro-chemical work both kathode and anode actions play an important part.

Thus, in dyeing, some processes depend upon oxidation, whilst others require a reducing or de-oxidising action. In *electro-dyeing*, advantage is taken of the action of the electro-negative ions, which are set free at the anodes, to carry out the oxidising actions, whilst for the reducing actions the electro-positive ions set free at the kathode are available. Very complete processes have been worked out by Goppelsweder and others by taking advantage of these different actions.

In the *rectification of alcohol*, advantage is taken of the active properties of nascent hydrogen, as set free at the kathode of an electrolytic bath, whilst in *electric tanning* the passage of the current enables the skins to assimilate the tanning material much more quickly than in the ordinary process, the operation being thereby reduced from months to days. In the *purification of sewage* the oxidising action at the anode is chiefly relied on.

In *alkali manufacture* the chief raw material is common salt (sodium chloride), which can be directly electrolysed into sodium at the kathode and chlorine at the anode. The sodium is at once converted into caustic

soda, a valuable product, by contact with water or steam, and if carbonic acid gas is injected into the apparatus, the caustic soda is converted into carbonate of soda, one of the chief products in alkali manufacture. The chlorine liberated at the anode is utilised for the production of bleaching powder (chloride of lime), or of chlorate of soda, or potash, for all of which there is a large demand.

In the *extraction of gold* electrolytic methods are taking an important place, especially in connection with the widely used cyanide process for saving the gold contained in the "tailings" from the "stamp" mills. In this process the gold is converted into a double cyanide of gold and potassium; and the most recent method of obtaining the gold from the cyanide consists in depositing it electrolytically by weak currents on lead kathodes. The gold and lead are readily separated by cupellation, and the method has the advantage over older methods of yielding a purer gold and using a smaller quantity of cyanide. It is stated that in the Transvaal alone over 1,000,000 tons a year of tailings, which were formerly discarded, are now treated by this process.

The electrolytic *refining of copper*, now very largely employed for the production of the high conductivity copper required for electrical purposes, depends upon the deposition of pure copper at the kathode of the bath. Similarly, weldless copper tubes are formed by the electro-deposition of copper on suitable mandrils used as kathodes, the tube being afterwards readily separated from the mandril.

It must not be overlooked that electrolytic processes are now used by chemists for true *electrolysis* or *electric analysis*, although it is found that in order to obtain accurate results minute precautions must be taken which were not realised as necessary at the time of Faraday's early discoveries.

Further applications of the chemical effect of the current will be referred to later on; enough has perhaps been said here to show that these applications occupy a position of rapidly increasing importance in modern industries.



## CHAPTER VI.

## THE THERMAL EFFECT OF THE CURRENT.

## I.—FUNDAMENTAL LAWS.

THE heating effect of the current set up in the discharging circuit of a battery of Leyden jars has already been referred to. A short time after the discovery of the more prolonged current produced by a voltaic cell it was observed that a wire which has such a current passing through it may become considerably heated. Davy ascertained that the heating

becomes the more noticeable the stronger the current and the greater the resistance of the wire; but exact investigations were first made by Joule (1841). To show that a wire becomes heated when a current passes through it, he used the apparatus shown in Fig. 194. Instead of the ordinary bulb for the mercury, the thermometer *s* has a tube *G* bent in spiral form. The lower end of this tube has a platinum wire  $p_1$  fused into the glass, and connected with the binding screw  $k_1$ ; a platinum wire is also fused into the glass at  $p_2$ , and connected with  $k_2$ . When the poles of a voltaic battery are attached to  $k_1$  and  $k_2$ , the circuit is completed through the mercury in *G*. On the passage of the current the mercury, becoming heated, will expand, and the extent of the expansion will be shown by the rising of the mercury in the tube *s*. Joule also measured

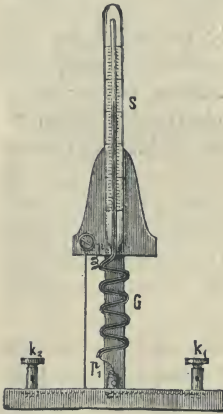

Fig. 194.—Joule's Current Calorimeter.

the heating effect of a current through a wire in other ways. One of his plans consisted in winding a wire round a very sensitive thermometer and immersing it in water. By this means he discovered the following law: "the heat generated in a conductor by a current is directly proportional to the resistance of the conductor." He further asserted that the heat generated in a certain wire in a given time by a current changing its strength must be proportional to the square of the strength of current. Experiments made by others confirmed this conclusion, and the law, known under the name of Joule's law, may be stated as follows: *the quantity of heat generated in a certain time in any part of the circuit is directly proportional to the RESISTANCE of that part of the circuit and to the*

SQUARE of the strength OF THE CURRENT. Experiments made by Becquerel and Lenz confirmed Joule's law; the apparatus Lenz used for the experiments, consisting of an inverted bottle and stopper, is shown in Fig. 195. The stopper *s* is fastened upon the support *n o*, and the bottle *G H* is made to fit it tightly. Two platinum wires are passed through the stopper, terminating in little cubes of platinum; to these platinum cubes a platinum spiral is fastened. The bottle *G H* is filled with alcohol (water being too good a conductor of electricity for exact measurements), and a sensitive thermometer *K* is tightly fitted into the bottle. By this apparatus it was proved that Joule's law holds good, not only for solid bodies, but for fluids also. If *c* be the strength of the current and *r* the resistance between two points of the circuit having a difference of potential *v*, then the heat, measured electrically, which is produced per second between these points, is  $c^2 R$  or  $c v$  (for by Ohm's law  $c R = v$ ).

Joule's law was one of the results which he obtained in the course of his classical researches on the conservation of energy and the mechanical equivalent of heat. In these the energy changes in a voltaic circuit played an important part. We have already (page 147) considered one aspect of this question

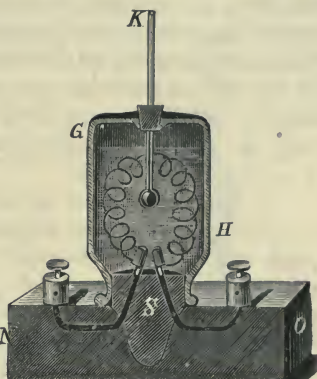

Fig. 195.—Lenz's Current Calorimeter.

in connection with the theory of the voltaic cell. We now return to it with reference to the thermal effects of the current in the circuit. We know that on the one hand the amount of zinc consumed in a battery in any time is proportional to the time and to the strength of the current; on the other hand, if we do not vary the *E. M. F.*, the heat produced is also proportional to the same two factors. It follows that the generated heat must be proportional to the quantity of zinc consumed. Favre found that 66 grammes of zinc used in a cell gave 36,320 heat units, or calories. (A heat unit, or calorie, is that quantity of heat which is required to raise 1 gramme of water from  $0^{\circ}$  to  $1^{\circ}$  C.) Now calculate what quantity of heat will be strictly equivalent to the energy of chemical combination liberated or of the energy of chemical separation absorbed. For the quantity of heat when zinc dissolves in sulphuric acid (that is, in the formation of zinc sulphate) the following result is obtained by using the tables already given for the number of heat units evolved or absorbed in the combinations that take place in the case before us.

By the conversion of zinc to zinc oxide	...	...	85,800	calories.
By the formation and solution of zinc sulphate	...	...	59,400	"
		Total	<u>145,200</u>	"

When the above quantity of zinc dissolves in  $H_2SO_4$ , 2 grammes of H are liberated as well. This takes up 107,600 calories of heat, the equivalent of the energy of chemical separation. This amount has to be deducted from the above ; we then obtain as the heat units generated by the chemical process  $145,200 - 107,600 = 37,600$  calories. Taking into consideration unavoidable sources of error, this result agrees very nearly with the result found by Favre.

Assuming, then, that no work external to the conductors is done by the current, the total amount of heat generated in a voltaic circuit is proportional to the amount of zinc used, and is equal to the quantity of energy which becomes free by the chemical action in the cell. If the cell is short-circuited, the whole of the chemical energy liberated appears as heat energy in the cell and in the short-circuiting wire. It is impossible to destroy energy, and all we can do is to change it into some other form. In our case the electric current shows no other result of the energy imparted to it except that of heat.

By generating heat in the different parts of a circuit, the temperature of these parts must be increased ; upon what does the temperature of the parts in the circuit depend ? The temperature of any body depends upon the difference between the quantity of heat it generates within itself, or obtains from without, and the quantity of heat it loses to surrounding bodies. The temperature of a body becomes constant as soon as the heat received or generated is equal to that radiated. Joule's law tells us upon what the quantity of heat generated in any wire depends, and we know from experiments on radiation that the loss of heat depends upon the nature and extent of the surface of the body and the difference of temperature between the body and its surroundings. The temperature of a wire depending upon the quantity of heat generated and the heat radiated will be the higher the greater the current and its own resistance and the smaller its surface and power of radiation. When these conditions are favourable the wire will pass to a red heat, then to a white heat, and will finally fuse. A thin wire, therefore, is easily made red-hot : its resistance on the one hand is very high ; on the other hand its surface for radiating heat is but small.

We have seen that the electric energy ( $w$ ) spent in the circuit is given by the equation

$$w = Q E$$

where  $Q$  is the quantity of electricity and  $E$  the E. M. F. Also  $Q$  is equal to the current multiplied by the time if the current be steady, or

$$Q = C t$$

$$w = C E t.$$

Then, from Ohm's law, we have

$$E = C R,$$

and therefore finally

$$w = C^2 R t.$$



If, therefore, the whole of the electric energy ( $w$ ) is converted into heat, this heat must be given by the expression  $C^2 R t$ . The form of this expression shows that it is applicable to parts of a circuit as well as to the circuit as a whole, and we are thus justified in deducing Joule's law in the form already given. If the heat ( $H$ ) produced is expressed in calories and not in electrical units, we need only introduce an appropriate multiplier into the above equation, which may then be written

$$H = 0.24 C^2 R t$$

where  $H$  is in calories,  $C$  in amperes,  $R$  in ohms, and  $t$  in seconds.

The heating of wires by the electric current may be shown by connecting the wires of a battery (short, thick copper wires) with a thin platinum or iron wire. The resistance in the battery should be reduced as much as possible by selecting cells with large plates, or if large plates are not at hand, by arranging small cells, not in series, but in parallel. With these

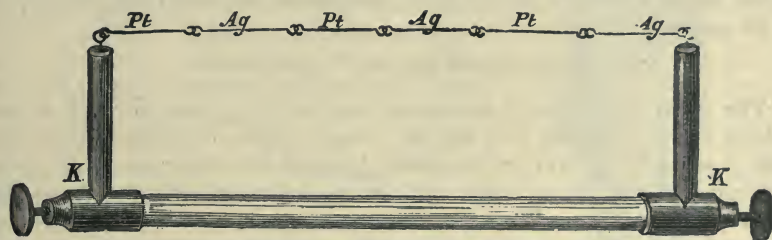

Fig. 196.—Heating Effect of Current on Platinum and Silver.

conditions it is possible to cause most of the heat generated by the current to show itself in the platinum wire.

It follows from what we have said above that the quantities of heat generated in different parts of a simple circuit depend upon the resistances of these parts. If, therefore, we wish to produce heat chiefly in one of these parts, that particular part must have a great resistance, whilst the resistance of all the other parts of the circuit must be reduced as much as possible. It has been mentioned that different bodies possess different specific resistances; hence, in the heating of bodies by means of the electric current, different temperatures must be reached when bodies having the same dimensions, but consisting of different materials, are taken. That this really is the case may be shown by arranging platinum and silver wires as in Fig. 196. It will be found that the platinum links begin to glow whilst the silver links show no visible sign of heat. Again, the surrounding medium affects the temperature of a wire; for instance, Grove heated a platinum wire in air, and then introduced the red-hot wire into a vessel filled with hydrogen gas; the wire lost its redness immediately.

The experiment just described in which the links of platinum (Fig. 196) can be made to glow with a full white heat whilst the links of silver and

the rest of the circuit remain dull and cold at once suggests the possibility that *the heating effect of the electric current may be used for the production of artificial light*. Indeed, at first sight, the experiment appears so promising that it is almost with a shock of disappointment that we learn that the working out of the idea so as to produce a practical and economical system of electric lighting has called for long years of patient work by numerous inventors, and even then has only been partially accomplished, by the almost accidental coincidence of other developments in widely remote branches of physics. We advisedly say only "partially" accomplished, for there are still details connected with the modern glow lamp which call for further improvement, and upon which inventors are still at work. The main principles and general lines of the solution of the problem are, however, well established, and with them and the early historical development we shall deal here, leaving to the later portion of the book the description of the technical details which have contributed so much to the success so far secured.

#### II.—INCANDESCENT OR GLOW LAMPS.

The general problem is to arrange an electric circuit in such a way and with such materials that on the passage of the current one part of it shall glow with a bright red or white heat whilst the temperature of the remainder of the circuit shall not be raised inconveniently above the ordinary temperature. We have seen that this requires that the material used at the glowing part of the circuit (1) shall have a high resistance per unit length as compared with the rest of the circuit, and (2) that its radiating surface, and therefore its mass, shall also be relatively small. We shall then secure that the heat produced by the current will have to raise the small mass to a high temperature before the steady state is attained in which the small surface will be able to radiate the heat as quickly as it is produced, for until this result is reached the temperature must continue to rise. The two conditions laid down fortunately both require that the conductor selected for producing the effect shall have as small a cross-sectional area as possible. This evidently tends to give a small radiating surface and small mass, and as regards the resistance we have seen (page 184) that

$$R = \rho \frac{l}{A}$$

where  $R$  is the resistance,  $l$  the length,  $A$  the cross-sectional area, and  $\rho$  the specific resistance of the conductor. Thus a decrease in the value of  $A$ , the cross-sectional area, increases the resistance. The sectional area is therefore to be made as small as considerations of fragility and the limitations of manipulative skill render possible.

In regard to the length the conditions are antagonistic, for whilst increase of length increases the resistance, which is desirable, it also increases

the radiating surface, and therefore partially violates condition (2). In this respect, therefore, a compromise, to be determined by experiment and other considerations, must be adopted.

The material selected should have, if possible, a high specific resistance, and at first sight there appears to be a fair number of conductors fulfilling this condition and also sufficiently ductile to be drawn into thin wires. It is, therefore, somewhat curious that, for reasons which will appear in the sequel, the material which, for this purpose, has until recently driven all others from the field should be carbon, which has practically no ductility at all. It, however, fulfils one further condition not alluded to above, namely, that it is very refractory.

**Historical Notes.**—Although it is only within the last thirty or thirty-five years that glow lamps have been constructed in such forms and with such qualities as to answer practical purposes, attempts to produce them cover a much longer period. Jobart, in Brussels, proposed (1838) to make use of a small carbon in a vacuum. F. Moleyns, of Cheltenham, in 1841, took out a patent for a lamp which had a glowing platinum spiral upon which coal-dust was allowed to fall. Du Moncel (1859) obtained very good results by experimenting with carbon filaments made from cork, sheep-skin, etc. Subsequently Konn and others worked at the subject, producing lamps, some of which were simple, whilst others were more or less elaborate. Konn's lamp is shown in Fig. 197, and it is interesting to compare the complicated details of its construction with the simpler forms now in use. The part of the circuit which is to emit light is one of the rods  $\epsilon$ , of which there are five. Only one is in the circuit at a time, but as each fails a new one is switched in until each one of the five has been used. The vessel is exhausted through the valve  $\kappa$ , which opens outwards.

The critical period for glow lamp lighting occurred between the years 1877 and 1880, during which attempts more or less successful were made to produce a workable glow lamp. Before referring to the labours of Swan in England and of Edison in America it may be mentioned that Sawyer and Mann, in a patent taken out in November, 1878, endeavoured to get rid of the difficulty which previous experimenters had found due to gases

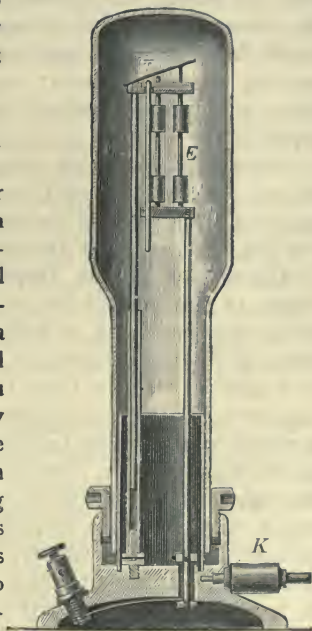

Fig. 197.—Konn's Lamp.



occluded in the carbon filament, by raising the filament to a glowing temperature by means of an electrical current, and then allowing it to cool in nitrogen. They also, apparently for the purpose of hardening the filament, adopted a method very widely used subsequently for another purpose. This consisted in raising the filament to incandescence in an atmosphere of a hydro-carbon gas, so that small particles of carbon were separated out from the gas and deposited on the filament, producing the effect indicated. Lane-Fox, also, in November, 1878, took out a patent for a glow lamp in which the carbon filament was made from a special kind of grass. In December, 1878, Swan exhibited, at a meeting of the Newcastle-on-Tyne Chemical Society, a glow lamp (*see* Fig. 200), which he afterwards produced, three months later, after it had been running during February and March of 1879. Edison, in December, 1879, took out a patent for a glow lamp with carbon made from paper.

Swan, who had been carrying on his researches in partnership with Stearn, took out a patent in January, 1880, for his now well-known glow lamp. Edison's patent for the lamp with the filament made from bamboo (*see* Fig. 198) is dated December, 1880.

**Causes of Rapid Development.**—Besides these advances in the details of the manufacture of the conducting filament, the time was ripe for the production of a workable glow lamp on account of the advancement of practical science in two other directions. Firstly, it is necessary in a carbon filament lamp that all oxygen should be removed from the enclosure in which the filament is placed. Otherwise, when the filament is raised to a glowing temperature, the carbon will unite with the oxygen in the usual manner, forming carbon-dioxide gas, and the filament will be destroyed. It was during the years 1875 and subsequently that such improvements were made in mercury air-pumps as to render them available for ordinary use in the factory. Without these improvements and developments carbon filament lamps could not have been produced at that time in large numbers for actual practical use.

Another factor which largely assisted in the development of the glow lamp was the development of the dynamo electric machine, which took place in the year 1878 and the years immediately following. The improvements then made rendered available for the first time the supply of electrical energy in large quantities at a price which brought the using of electric lamps within the range of practical politics. It will therefore be seen that it was the synchronising of the improvement of the mercury air-pump with the development of the dynamo electric machine that brought electric lighting by glow lamps within the range of commercial success in the years above referred to.

**Materials Available for the Filament.**—Returning now to the development of the conductor, the earlier inventors had used either

platinum wires or carbon rods or filaments. Platinum appeared to fulfil more than one of the fundamental conditions. As a metal it has a comparatively high specific resistance, nearly six times that of copper, and is sufficiently ductile to be drawn into fine wires or filaments. It also has a high fusing point, and is not acted upon by the gases of the atmosphere. The only drawback that at first presents itself is that of cost, for this metal approaches gold in value. Unfortunately, however, experience showed that when kept at a high temperature by an electric current the metal slowly disintegrates, and that a lamp made of a very fine filament of platinum, instead of being indestructible, has only a short life. This disadvantage, combined with the high price of the metal, accounts for the failure of early inventors to produce a platinum filament lamp that had any chance of success in ordinary electric lighting.

Carbon, on the other hand, in addition to its lack of ductility, to which we have already alluded, has the great disadvantage that at a red heat it combines readily with the oxygen of the air and is dissipated as a gas; therefore a thin filament or rod brought to a red heat in the open air will quickly burn away. It is therefore necessary to remove all oxygen from the interior of the lamp, though an inert gas like nitrogen might be left. One great advantage of the selection of carbon as the material of which the filament of the lamp is to be composed is that in one form or another it is very widely diffused; in fact, carbon forms the basis of all vegetable and animal organised structures, so much so that the chemistry of the carbon compounds is known as organic chemistry.

For many years it was accepted almost without question that, platinum having been found unsuitable, the only possible material was carbon, notwithstanding the fact that its efficiency, as measured by the candle power obtained per watt, was low, and that its resistance diminishes with rise of temperature. The last-named property is undesirable for a glow lamp which has to be run on supply mains in which the pressure may vary. On the other hand, metals and alloys have a positive temperature coefficient, and hence the increase of current caused by a rise of voltage will be checked by the increase of resistance due to the higher temperature thereby induced. The difficulty is to find a metal which combines the property of a high melting-point with the possibility of being worked up into the sufficiently fine filament necessary for the pressures of 100 to 250 volts now in ordinary use. The problem is, however, well worth solving, and during the last two or three years has been attacked by a host of workers.

The first non-carbon lamp, the "Nernst," produced some years ago, was not metallic, but had a stick or "glower"—it can scarcely be called a filament—made of the oxides of yttrium and zirconium. The Nernst lamp has the disadvantage of being non-conductive when cold, and it is necessary to heat it before the current can be passed. It therefore requires a "heater" to start it, and an electromagnet to switch the heater out of

circuit when the current passes. In addition, as the resistance diminishes seriously with rise of temperature a series or "ballast" resistance has to be put in circuit with the glower to steady the current. Further particulars will be given in the technical section.

Of the metallic filament lamps, the first one which offered a commercially possible solution was the "Tantalum" lamp of Messrs. Siemens and Halske. Tantalum is a very hard metal of high melting point, which in the pure state, was found by Messrs. Siemens and Halske to be ductile and

to have a high tensile strength. It can be drawn down to the necessary fineness for a lamp to give 25 candle power on a 110-volt circuit. Other metals which have by various processes, more or less elaborate, yielded solutions of the problem are osmium, zirconium and tungsten. Coating a carbon filament with metal has also been tried, but further reference to these and other devices must be postponed for the present. We shall conclude this part of the subject with

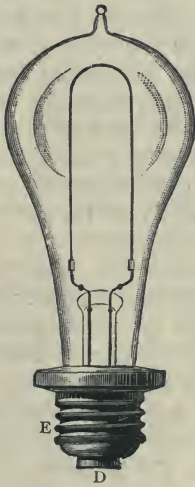

Fig. 198.—Edison's Bamboo Lamp.

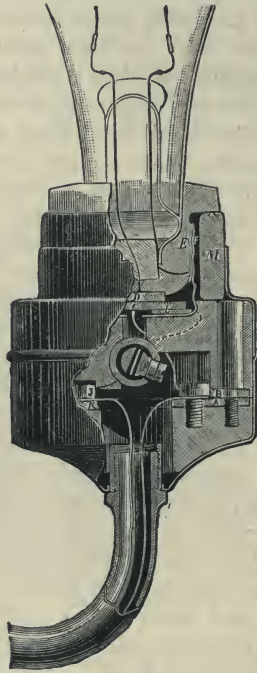

Fig. 199.—Edison's Early Form of Lamp Holder.

a few historical remarks upon the early carbon lamps of Edison and of Swan.

**Edison's Glow Lamp.**—The first glow lamp which T. A. Edison constructed had platinum wire, similar to one devised by Changy, but the disintegration of the platinum when heated, already alluded to, led him to abandon this form. He then examined the properties of many organic and inorganic substances, with the view to finding the best substance for the filament, and finally fixed upon bamboo fibre.



By means of machinery the bamboo was divided into fibres of 0.04 inch in diameter, and 5 inches in length. These fibres were pressed into U-shaped moulds, and were put by thousands into ovens, where they were allowed to become carbonised. The carbon filament was attached to platinum wires, which were fused into a glass globe having the form shown in Fig. 198. The glass globes were exhausted by air-pumps, constructed by Edison for the purpose, and during exhaustion an electric current was sent through the carbon filament, for the purpose of driving off any gases which might have been absorbed by the carbon. To prevent the temperature of the platinum wires from being raised too high, the carbon filaments were considerably thicker at the end connected with the platinum wires, so as to offer there less resistance to the current. The free ends of the platinum wires were connected with the copper pieces D and E (Fig. 198), which were insulated from each other by plaster-of-Paris. The piece E was made of thin sheet copper, and was cylindrical in shape, with a coarse screw thread embossed on it. In the lamp holder, F and C were copper pieces separated by the disc L, consisting of insulating material; M was a wooden ring serving to insulate the different metal plates from each other. By screwing in the lamp, contact was made between the cylindrical pieces E and F and between the plates C and D at the same time. By means of the plates B, A and J, K, which touch one another, contact was made within the lower wooden ring. This ring consisted of two portions covered with sheet brass. The first portion was connected with the wires leading from C and F, whilst wires from the circuit were clamped by means of screws against the plates A and K. The holder contained a key for switching the current on and off.

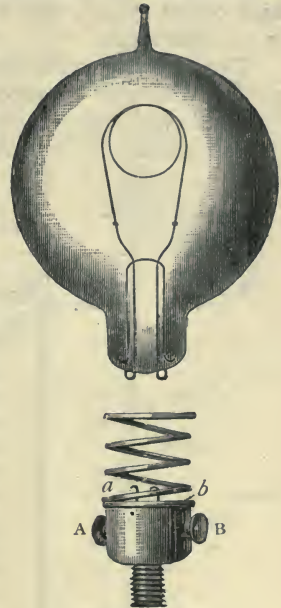

Fig. 200.—Swan's Early Lamp.

**Swan's Glow Lamp.**—In these early days Swan also did much towards the perfection of glow lamps. Long before Edison, he tried to obtain more durable carbon filaments. Too little attention had been paid by other experimenters to the exhaustion of the vessel containing the carbon, and also to the diminution of resistance at the ends of the carbon connected with the platinum wire. Fig. 200 shows an early lamp made by Swan. The platinum wires were carefully fused into a little glass tube ending in two loops outside, which formed the terminals of the lamp. The lower portion consisted of vulcanite which had a gas screw, by means

of which the lamp might be screwed upon any ordinary gas-arm after removal of the burner. The vulcanite carried two platinum hooks *a* and *b*, connected with the terminal screws A and B respectively. The carbon was four inches long, and was prepared from cotton fibres soaked in sulphuric acid (2 parts acid to 1 part water); they underwent a similar change to paper when similarly treated, *i.e.* artificial parchment was obtained. The fibre, which after the treatment was more tenacious, was then bent into the form required, and was placed in a crucible which was filled with fine coal-dust and hermetically closed, being afterwards exposed to a gradually rising temperature for some hours. The carbons were fastened to the platinum wires by making the ends overlap and then binding them together with cotton thread, which was afterwards carbonised by a further heating in a closed space.

The following particulars of these early lamps are of interest for comparison with the corresponding data for modern carbon filament lamps produced with the improvements suggested by scientific research and the experience of manufacturing them extending over a quarter of a century:—

EARLY CARBON FILAMENT LAMPS.

Make and Type.	Candle-power.	Voltage.	Resistance (hot).	Current (amperes).	Power absorbed (in watts).	Efficiency (candle-power per watt).
<i>Edison—</i>						
A Lamp	16	103	140	0·74	76	0·21
„	32	103	70	1·47	152	0·21
B Lamp	8	56	70	0·80	45	0·18
„	10	103	250	0·41	42	0·24
<i>Swan—</i>						
Class A <sub>2</sub>	16	36	25·3	1·42	51	0·31
„ A <sub>1</sub>	18	41	32·0	1·28	52	0·35
„ B <sub>1</sub>	20	46	34·8	1·32	61	0·33
„ C	20	50	37·2	1·34	67	0·30
„ D	20	52	42·1	1·24	63	0·32
„ E	23	54	44·6	1·21	65	0·31

Reference to the last column shows that the early Swan lamps were about 50 per cent. more efficient than the early Edison lamps. On the other hand, they were of much lower resistance, took larger currents, and were constructed for a much lower voltage. For the practical purpose of a public supply of energy throughout a district for domestic electric lighting the Edison lamps were the better, notwithstanding their lower efficiency.

In view of the great variety of carbon filament lamps now commercially obtainable, and the wide range of the behaviour of the different specimens when tested, it is not easy to draw up a similar table for modern lamps, but the following may be taken as average figures which may be expected from the ordinary commercial lamps. For obvious reasons names of makers are not given. Only 16 candle-power lamps are referred to.

MODERN CARBON FILAMENT LAMPS.

Candle-power.	Voltage.	Resistance (hot).	Current (amperes).	Power absorbed (watts).	Efficiency (candle-power per watt).
16	110	242	0.455	50	0.32
16	200	645	0.31	62	0.26

Very closely following Edison and Swan in point of time, excellent and thoroughly practicable lamps were produced by Maxim, Lane-Fox, and others. Some of these will be found described in the earlier editions of this book. Modern lamps will be referred to later.

**Mercury Air-Pumps.**—We have already remarked that the practical success of carbon filament glow lamps was closely associated with the almost simultaneous development of the mercury air-pump as a convenient and rapid means for producing the vacuum, without which the lamps could not be used. For this reason, and also because the principles and details are interesting in themselves, a brief description of such pumps will not be out of place here.

The fundamental experiment from which the history of mercury air-pumps starts carries us back to the year 1643, when Torricelli discovered the existence of the vacuum at the top of the mercury in a barometer tube. Torricelli's experiment is shown in Fig. 201. A tube A of

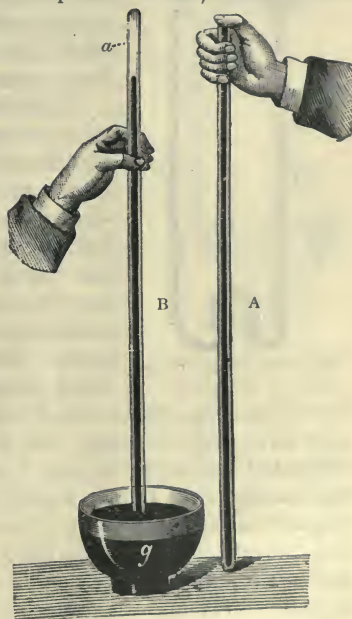

Fig. 201.—Torricelli's Vacuum.

thick glass, usually about half an inch in external diameter and closed at one end, is carefully filled with mercury free from air. The thumb being placed over the open end, the tube is inverted, and the open end intro-



duced below the surface of the mercury in a vessel *g*. On the removal of the thumb from the end of the tube the mercury inside, if the tube be over 30 inches long, falls until the top surface of the mercury is about 30 inches above the surface of the mercury in *g*. The explanation is that the pressure of the atmosphere on the surface of the mercury in *g* can be balanced, hydrostatically, by that of a column of mercury of the length mentioned. This length is usually referred to as the "*height of the barometer*," and as the pressure of the atmosphere varies from day to day, so does the barometric height and the length of the mercury column in the tube *B*.

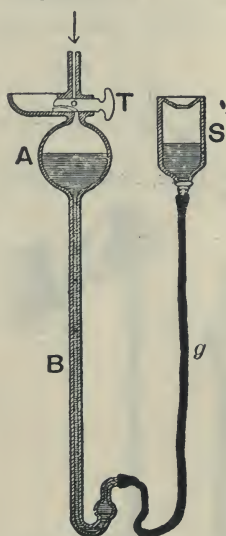

Fig. 202.—Geissler's Pump.

But the space at the top of *B* is empty if the experiment has been carefully performed, for no air could get into the tube after the removal of the thumb, and before that the tube was full of mercury. A good vacuum can therefore be obtained in the space *a*, and as the pressure in *B* required to balance the atmospheric pressure is a question of vertical height only, it is possible to enlarge the space *a* in which the vacuum is produced whilst the tube *B* is kept narrow.

Many attempts were made to utilise this principle in a convenient form for the production of a vacuum, but the next great step in advance calling for notice is due to Geissler, who, in 1855, designed the pump shown in Fig. 202. To avoid the difficulty of inverting the filled mercury tube Geissler placed at the top a three-way tap *T*, which in one position put the enlarged space *A* in communication with the external atmosphere, and in the other joined *A*, by the narrow tube shown, to the vessel to be exhausted. The open vessel *s* is connected to the lower end of the barometer tube *B* by means of a flexible rubber pipe *g*. Let now *s* be placed on a level with the lower end of *B* and filled with mercury; let also *A* be connected through the tap *T* with the outer atmosphere. On raising *s* the mercury will rise in *B* and drive the air in *A* in front of it, out into the atmosphere through *T*; *s* is to be raised until the whole of *B* and *A* and the passages of *T* are filled with mercury. *T* is then closed entirely, and *s* dropped to its former lowest level; the mercury thereupon leaves *A* and stands in *B* at the barometric height. We have now a good vacuum in *A*, and on turning *T* so as to join *A* to the vessel to be exhausted some of the air in the latter rushes in to fill the space *A*. The tap *T* is now turned to the first position, and the whole cycle of operations, consisting of the raising and lowering of *s*, etc., is repeated several times. At each repetition air is withdrawn or pumped from the

vessel which is being exhausted, until finally a fairly good vacuum is obtained.

In this form the Geissler pump had several drawbacks, and difficulties were experienced, notably with the tap  $\tau$ . The advantages and convenience of the method were so great, however, that many attempts were made to improve the details, amongst those who worked at the problem being the well-known physicists Joule, Töpler, Siemens, and others. Space will not permit us to trace the development in detail, and we shall next refer to Töpler's pump as shown in Fig. 203.

The great advance made here consists in the abolition of all taps and valves. The parts  $A$ ,  $B$ ,  $g$ , and  $s$  remain as before, but the tap  $\tau$  (Fig. 202) has been replaced by a connection to the top end of a barometer  $F$ , which serves both as an exit tube and as a gauge; an inverted U tube  $H$  has one end sealed into the neck of  $A$  and the other end  $R$  connected to the lamps or vessels to be exhausted. It is necessary that the vertical height of  $H$  should be greater than the barometric height. When now the vessel  $s$  is raised, the mercury as it rises in  $B$  first closes the opening of the side tube  $H$ , and then proceeds to sweep the air in  $A$  down the barometer tube  $F$ , and out into the open air.  $A$  is eventually filled with mercury, and then  $s$  is lowered; the mercury falls in  $A$  and rises in  $F$ , which cuts off the communication with the outer air. On the mercury in  $A$  falling below the junction with  $H$  the latter and its attached lamps become again connected with  $A$ , which is, however, now vacuum; the result is that air rushes into  $A$  from  $R$  and  $H$  to fill the empty space. The process of raising and lowering  $s$  can now be repeated, and with each stroke of the pump more and more air is withdrawn from  $R$  and  $H$  until a fairly good vacuum is obtained.

Good vacua can be obtained rapidly with pumps working on this principle, but to remove most of the residual particles of air and to obtain the highest vacuum hitherto produced artificially another principle which we owe to Sprengel is made use of, at least, in the last stages of the process of exhaustion. Instead of the contained air being driven upwards by a rising column of mercury, small globules of it are trapped by pellets of mercury falling down a narrow tube, and these globules are mechanically carried down by the weight of the mercury above them until they are discharged at the lower end of the tube. A simple method of doing this is shown in Fig. 204. Flexibly connected to the lower end of a funnel  $s$  containing a supply of clean mercury is a long fall tube  $F$ . At the upper end of  $F$  a side tube, sloping downwards, is fused on as shown, the other

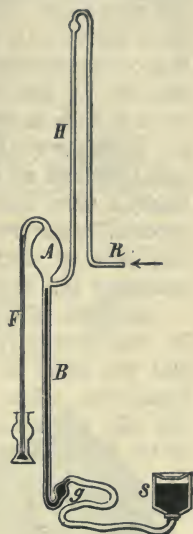

Fig. 203.—Töpler's Mercury Air Pump.

end of this side tube being connected to the apparatus that has to be exhausted. The lower end of *F* dips under the surface of some mercury contained in an open vessel *K*. The flow of mercury down the fall tube can be regulated by a suitable clip on the flexible connection at the top. This clip is adjusted until the falling mercury column breaks into a series of detached portions which successively pass the opening at the end of the side tube. As each pellet passes the open end the space above it is filled with air drawn from the side tube, the communication with which is immediately afterwards cut off by the next pellet closing the opening, whereupon the air so entrapped is carried bodily down the tube *F*. In this way the air is continually withdrawn from the side tube and all apparatus in communication with it, until finally a very high degree of exhaustion is attained. The process, however, is obviously a slow one, and it is therefore best to start the exhaustion by Geissler's method, reserving the Sprengel method for the final stages.

A form of Sprengel's pump is shown in Fig. 205. In this form a bend is introduced between the funnel *S* and the place at which the mercury column begins to break into pellets at the top of the fall tube. As before, the clip *a* on the flexible connection below the funnel is to be adjusted until these pellets are formed in convenient sizes. A hand-pump is shown connected to the side tube for the purpose of rapidly removing the air in the early stages of the exhaustion. A barometric gauge *G* has its upper end connected to the same side tube, and serves, by comparison with a standard barometer, to indicate the degree of exhaustion attained.

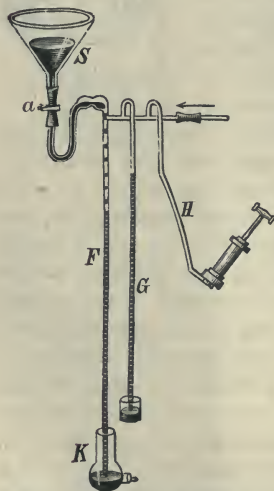

Fig. 205.—Sprengel's Mercury Air Pump.

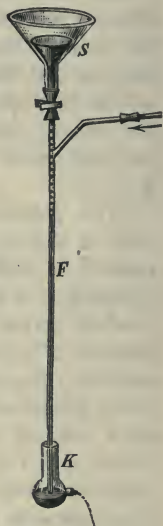

Fig. 204.—Principle of the Sprengel Pump.

Many ingenious and complicated combinations of Geissler and Sprengel pumps have been invented from time to time by Gimmingham and others. In some of these successful attempts have been made to shorten the length of the fall tubes, and generally to make the whole apparatus more compact; but we should be led too far from our main purpose if we entered into detailed descriptions of these. Some of the modifications actually in use in manufactories will be described in the technological section.

Many ingenious and complicated combinations of Geissler and Sprengel pumps have been invented from time to time by Gimmingham and others. In some of these successful attempts have been made to shorten the length of the fall tubes, and generally to make the whole apparatus more compact; but we should be led too far from our main purpose if we entered into detailed descriptions of these. Some of the modifications actually in use in manufactories will be described in the technological section.



## III.—PHYSICS OF THE GLOW LAMP.

Some interesting physical problems occur in connection with the ordinary carbon filament glow lamp. It has already been mentioned that Sawyer and Mann heated the filament to incandescence in an enclosure filled with a hydro-carbon gas for the purpose of strengthening it by the deposition of carbon from the gas on the glowing filament. This process, as we shall see later on, is also used to bring the filament



Fig. 206.—Carbon Filament of Incandescent Lamp.

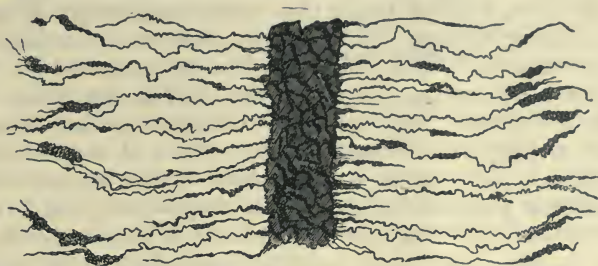

Fig. 207.—Magnified Diagram of Carbon Filament.

to a definite uniform resistance, and has been so employed by many inventors. It is known as "flashing." The effect on some classes of filaments is shown in Figs. 206 and 207. Fig. 206 represents a carbon filament with its deposit in its natural size, whilst Fig. 207 represents the same filament magnified 80 times. It will be noticed that the deposited carbon has a very irregular appearance relative to the original solid carbon of the filament.

Another interesting detail in the use of carbon glow lamps is the evident slow disintegration of the filament. It will now be a matter of common observation that ordinary glow lamps that have been sometime in use become blackened by a deposit on their interiors, this blackening tending seriously to interfere with the transparency of the glass. It is due to the disintegration of the carbon filament by electronic discharges. If the lamp has been much over-run a relatively transparent streak on the surface of the glass can sometimes be observed, as shown at *bb*, in Fig. 208. A careful examination of the lamp will lead to the inference that this streak is the shadow of one

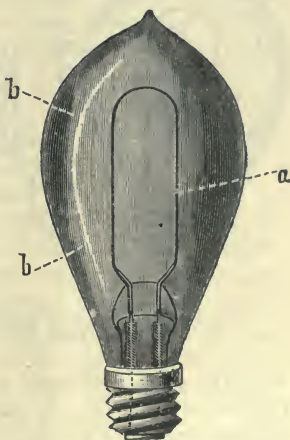

Fig. 208.—Molecular Shadow in Ruptured Glow Lamp.

side of the filament, the particles blackening the glass on either side of the streak having been shot off from the other side of the filament, say from point *a*, at which it will be probably found that the filament has been broken. It is natural to suppose that the point *a* was a point of small cross-sectional area, and therefore of high resistance in the filament, and that the temperature here was raised much above the normal. Whilst in this highly incandescent state the carbon particles were shot off from the glowing point in straight lines, and the streak *bb* on the glass was shielded by the other leg from the particles so shot off.

Even on ordinary incandescence, as shown by the gradual blackening of the bulbs, it would appear that carbon particles are being detached from the glowing filament. This view is supported by an experiment made by Edison as early as 1884, and called, from its discoverer, the "Edison Effect." One way of showing this is depicted in Fig. 209. A glow lamp with a U-shaped filament with the usual terminals *A B* has, in addition, a metal plate *M*, supported between the legs of the *U* and connected to a third terminal *c*. On passing a current from *A* to *B* through the filament, and connecting a galvanometer between the points *A* and *c*, a steady current is found to flow through the galvanometer as long as the filament is glowing.

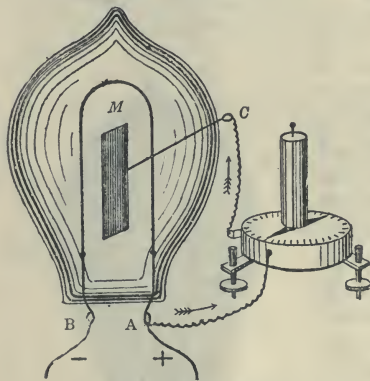

Fig. 209.—Connections for Showing the Edison Effect.

This current is in the direction shown by the arrows, and indicates the passage of negative electricity from the limb connected to *B*, the negative terminal, to the metal plate *M*, across the intervening vacuous space. The phenomenon is essentially one-sided, for if the terminals *B* and *c* be connected through the galvanometer no current can be observed.

Professor Fleming, who very thoroughly studied this effect in 1890, by a series of ingenious experiments in which he shielded the negative leg of the filament, that is the leg connected to *B*, in various ways, proved that there was an actual stream of negatively electrified particles passing from the negative leg to the metal plate *M*. It will be seen that this explains the existence of a current through the galvanometer, as shown in Fig. 209, for the plate *M* being connected to the positive terminal of the supply becomes positively charged, and when bombarded with negatively charged particles, its positive charge is being continually cancelled, necessitating the flow of a positive current through the galvanometer to renew the charge as quickly as it is dissipated. Professor Fleming, by using condensers, and in other ingenious ways, showed that the plate *M* does receive a negative

charge from the filament under the conditions and in the way indicated. He finally proved by the experiment depicted in Fig. 210 that the effect takes place even in the open air. Fig. 210 shows an unshielded carbon filament; and during the few seconds in which this carbon filament can be maintained at incandescence in the open air before it is finally consumed, the "Edison Effect" is shown upon the galvanometer G.

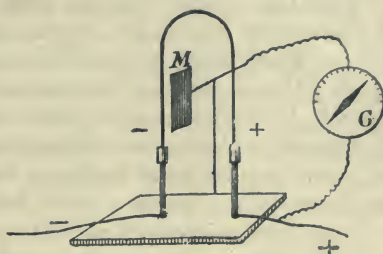

Fig. 210.—"The Edison Effect" in the Open Air.

The phenomena described above are now known to be due to the discharge of the negative "electrons" already alluded to (*see* page 200), which play such an important part in all electrical actions. The rate of

discharge of these electrons at a given voltage depends on the material, and carbon has been shown by Professor Fleming's researches to be a material in which it may be as large as one ampere per square centimetre of surface at the usual temperatures at which glow lamps are worked. It is very much less in the case of metals, and further quantitative experiments on the point would be interesting.

**Metallic Filament Lamps.**—The metallic filament lamps to which reference has been made above have been so recently introduced to the scientific world that the special physical characteristics exhibited by them have not been studied with anything like the amount of attention that has been devoted to lamps with carbon filaments. The "Edison effect," as has been just remarked above, has been found to be given by the metallic filament, as well as by the carbon filament, and there are probably other peculiarities at present unsuspected.

One of the chief physical characteristics in which a metallic filament lamp differs from its carbon competitor is that its resistance has a positive temperature coefficient. In other words, as the temperature increases the resistance of the filament also increases, whereas the opposite is the case with a carbon filament. This property leads to a distinct advantage of the newer filament over the older one in its application to glow-lamp lighting, especially when the voltage is not kept absolutely steady. Suppose, for instance, that owing to some defect in regulation at the generating station the voltage is suddenly increased 5 per cent., then more current will be taken by the lamps, more heat will be generated in the filaments, and the temperatures will rise. In the case of the carbon filament lamp the increased temperature leads to a decrease in the resistance of the filament, which therefore leads to a still further increase of the current and of the energy absorbed by the lamp. The candle-power



is, of course, increased; but if, at the lower voltage, the lamp was already working at its normal candle-power, it will now be seriously overrun, the filament will be overstrained, and its life materially shortened.

With the metallic filament lamp the case is different. The increase of temperature due to the increase of current leads to an increase of resistance, which tends to check the increase of current instead of accentuating it. The increase of candle-power above the normal will therefore probably be less than in the other case, and the effects, both on life and on efficiency, will also probably be diminished. These theoretical conclusions are borne out by some figures to be given presently, but the elementary laws involved are worth a little further consideration.

It has been pointed out above that the *rate* ( $P$ ) at which heat is produced in the filament is given by the equation:

$$P = C^2R$$

But according to Ohm's law:

$$C = \frac{V}{R}$$

and therefore the above equation may be written:

$$P = \frac{V^2}{R^2} R = \frac{V^2}{R}$$

which is more convenient for our present purpose. If the voltage  $v$  be increased 5 per cent., the numerator of this fraction will increase rather more than 10 per cent. If, therefore, the denominator  $R$  be diminished, as with a carbon filament, the heat produced is still further increased, whereas if the value of  $R$  increase the increase counteracts to some extent the increase in the value of the numerator of the fraction, and the heat produced is not so great.

The following figures given by C. H. Sharp exhibit the differences of the effects with various classes of lamps caused by a 5 per cent. increase in the voltage above the normal:

Material of Filament.	Increase in Candle-power.	Increase in Efficiency. (Candle-power per Watt.)
Carbon ... ..	30 %	15 %
Metallised Carbon ... ..	27	13
Tantalum ... ..	22	11
Tungsten ... ..	20	10

It might be inferred from the figures in the last column that the carbon lamp behaves better under the increase of voltage, since its efficiency is increased 15 per cent. as against a 10 per cent. increase of efficiency for the tungsten lamp under similar conditions. The danger of this increased

efficiency, however, has been already alluded to. It must be assumed that when working at the lower voltage the lamp was already working at the highest safe temperature consistent with the preservation of the carbon filament for a sufficiently long period to ensure a useful life of say 1,000 hours. The increase of the efficiency by 15 per cent. means that the temperature is substantially greater, and that, although the lamp is more efficient and is giving out a greater amount of light for a given quantity of electric energy supplied, the filament is being subjected to a much greater strain, and will deteriorate much more rapidly. It is not possible to give a definite estimate of the shortening of the life of the lamp produced by this overstrain, but it may be safely asserted that the increased cost of replacing lamps run at this higher temperature will outweigh the saving on the cost of the energy supplied per unit of light obtained.

Another interesting physical characteristic of metallic filament lamps is the effect of the passage of the current upon filaments made of the metal tantalum. These effects for different types of current are well shown in Fig. 211, in which is seen the appearances of the filament

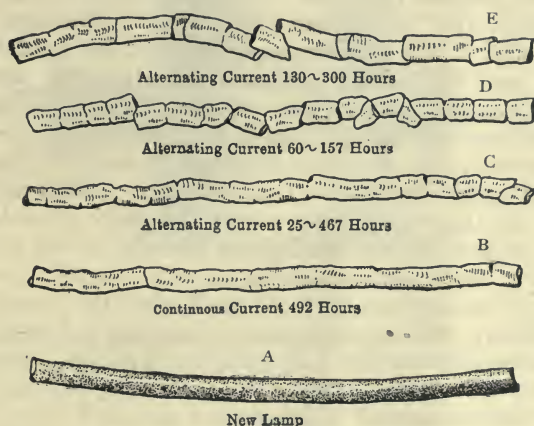

Fig. 211.—Effect of various kinds of current on a Tantalum Filament.

when examined under a microscope before and after the currents specified have been passed through it. The new filament is shown at A, and immediately above is the appearance after the passage of a continuous current for 492 hours. The original smooth appearance is marred by surface pittings, and in places the filament appears as if cut by a knife. When the current used is a rapidly reversed or alternate current, a type explained later (*see* Chapter XIV.), these changes

become still more marked, as shown in c, d, and e. In the latter two the filament appears to be broken up into sections jointed together, the joints in some places being very imperfect. The same effect, though not so pronounced, can be seen in c. This behaviour of the tantalum filament, which shows that it is not suitable for alternate currents, has not yet been explained. It is, however, worthy of note that no such effect has been observed with tungsten lamps.

#### IV.—THE ELECTRIC ARC.

A much more complicated "heating effect" of the current than that made use of in glow-lamps is witnessed in the now widely used arc lamps. Attention has already been called (*see* p. 82) to the breaking down of the dielectric and the passage of a "spark" when the electrostatic strains become sufficiently great. The light so produced does not necessarily imply the transformation of energy into the ordinary heat of hot solid bodies, although when radiated the radiant heat differs only from light in degree and not in kind. The "spark" referred to above is, therefore, not a purely "thermal" effect in the ordinary acceptance of the word, but since, in the main, as used for lighting purposes, thermal effects predominate, it will be convenient to consider some of them here.

When the circuit of a voltaic battery is interrupted at any place, a spark is observed similar to the one obtained from a Leyden jar. The sparks are obtained most easily with metals that evaporate or burn at the place of interruption, and their colour depends upon the metals which happen to be at the place of interruption. The spark, however, is not observed when the circuit of a battery consisting of a few cells is made.\* In this case we may explain the commencement of the spark when the circuit is gradually broken as follows: We have seen that a wire through which a current flows, glows most intensely when its cross-section is small. Such a diminution of section takes place always when the circuit of a voltaic battery is interrupted; the cross-section is diminished more and more as fewer and fewer parts touch each other, and finally, the few parts still in contact begin to glow, fuse, burn, or evaporate; the burning or evaporating particles then form the electric spark. We shall see later that when there is inductance in a circuit an additional reason exists for the formation of a brilliant spark at the place where the circuit is broken.

Voltaic batteries are able to give sparks still more resembling those from a Leyden jar when a great number of cells are combined. Crosse

\* Jacobi brought the poles of a twelve-cell zinc platinum battery, by means of a micrometer screw, to a distance of 0.00127 millimetre without obtaining a spark.



obtained sparks at the place of interruption with a battery of 1,626 copper-zinc cells in circuit. Gassiot saw for days sparks pass from a battery of 3,520 cells, the distance between the poles being 0.01 inch. Sparks can be made to pass continually, without using such large batteries, by bringing the poles of a powerful battery together, and then drawing them a short distance apart from each other, when we obtain what is known under the name of the *voltaic arc*. The first who observed the phenomenon was probably Davy (1802). Davy attached to the poles of a battery of 2,000 cells carbon rods, which he first allowed to touch each other and then separated. The sparks continued to pass until the distance of the carbons from each other was 4 inches, when he obtained a splendid arc of light

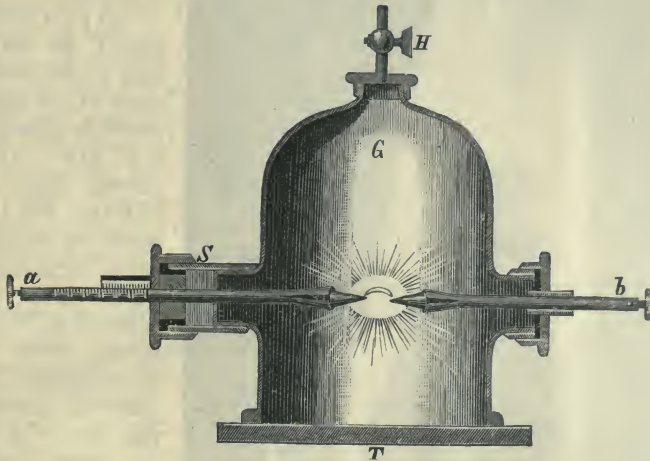

Fig. 212.—Arc Micrometer.

A very good effect is obtained by using 20 to 30 Grove's or Bunsen's cells. The length of the arc, that is, the distance of the carbon points from each other, may be ascertained by means of the apparatus devised by Wiedemann, shown in Fig. 212. *G* is a bell-jar, which fits the air-pump plate *T* airtight, and has at the top a stop-cock *H*, by means of which the outer air can be cut off. The rods *a* and *b* carry the carbon points. The rod *a* goes through the stuffing-box *S*, and has a scale to indicate the distance of the points from each other. When the air is exhausted in the bell-jar the points may be removed farther from each other without destroying the arc than when the jar is filled with ordinary air under ordinary pressure. Davy exhausted the air to 0.25 inch pressure, and moved the carbon points from 4.3 inches to 7 inches distance from each other. Deprez found that with a vertical arrangement of the carbons the arc becomes larger when the positive pole is above the negative pole. The arc is greatly influenced

by the material used for points, and it has been observed that the more volatile the material of which the electrodes are made, the more easily is the arc obtained. It is difficult to obtain an arc with platinum points; easier with points consisting of metals such as zinc, etc.; easiest with carbon points, especially when saturated with some salt solution. Casselmann obtained, with a 44-cell Bunsen battery, an arc 0.18 inch long when he

used carbon points, but an arc of double that length when he soaked his carbons in a solution of potash.

Attention should be drawn here to the curved shape of the spark which is shown in Fig. 212; this curved shape is caused by the electric stream being carried upwards by the currents of air which ascend from the heated space. The effect is interesting, as to it is due the term "arch," first used by Sir Humphry Davy and afterwards shortened to "arc," the term now universally employed to denote this form

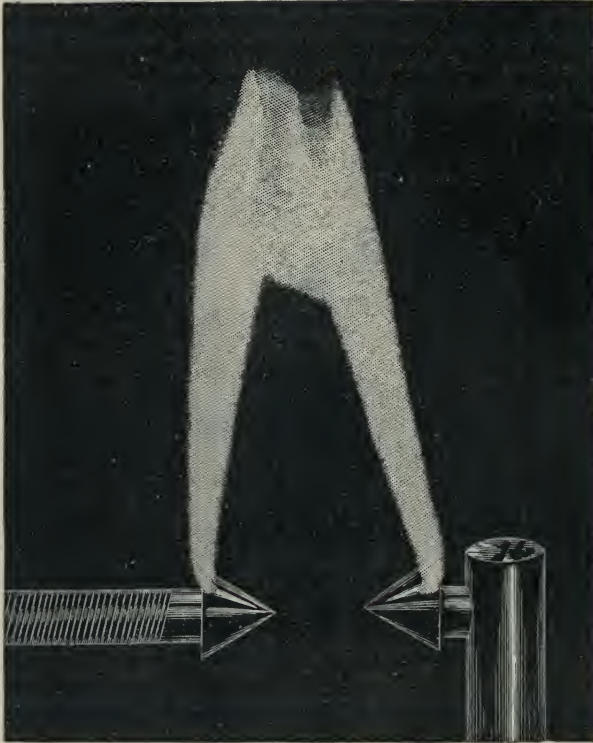

Fig. 213.—Alternate Current, 20,000 Volt Arc.

of continuous discharge. With the electrodes vertical the curved shape gives place to an almost straight line of light under ordinary circumstances.

The "arch" or "arc" form is still more strikingly displayed when, with horizontal electrodes, much higher potential-differences than usual are employed to produce the effect. Fig. 213 represents, on a scale which is one-half the actual size, an "arc" produced in some experiments of Messrs. Siemens and Halske, in which they used an alternate electric current with a potential-difference of 20,000 volts between the electrodes. This arc

made a "loud humming and clapping noise, and flapped about, being easily carried away by the slightest draught." Subsequent experiments by Crookes show that under these conditions the flaming discharge observed consists of endothermic flames of the nitrogen and oxygen of the air.

The appearance of an ordinary steady electric arc, as formed between solid carbon rods under the usual conditions for open arc lighting, is a beautiful phenomenon worthy of careful study. As the light is too dazzling

for direct eye observation, it is necessary to use some device for toning it down. Dark coloured glasses do this, but a better method is to project the arc with a convex lens on to a white screen, on which most of the details can be examined without discomfort. Fig. 214, taken from a drawing in Mrs. Ayrton's book on "The Electric Arc,"\* was obtained in this way. The arc used was 0.16 inch long, and was formed between solid carbons fed with a current of 20 amperes, at a P.D. between the carbons of 56 volts. The upper or + carbon forms a crater with an intensely bright surface, and gives out light in directions embracing an angle of about 65°. The end of the lower or - carbon, on the contrary, is pointed, and has a bright tip which, however, is not so brilliant as the + crater. The gas-like arc playing between the two has a beautiful violet central part fringed with a darker space, and surrounded by a greenish envelope. The ends of the carbon rods surrounding the brilliant tips referred to above are first a brightish yellow, which further off tones away to a duller red, and finally becomes dark. But the most curious appearances are the dark masses of viscous matter which seem to bubble and boil, and form bright spots round the bright carbon rods. On the - carbon these appear as bright boiling balls at the junction of the light and dark regions. On the + carbon, where they are not as bright, they appear more as the frayed ends of the outer cuticle of the carbon, which seems to be peeling off. The ends of these strips boil and bubble under the heat of the arc, and apparently are burnt up slowly.



Fig. 214. — Arc between Carbon Rods.

#### V.—ARC LAMPS.

The use of the electric arc as a light, either for experimental work or for illumination, was a problem which engaged the attention of many scientific men and inventors during the first three-quarters of the nine-

\* The *Electrician* Printing and Publishing Co., Limited.



teenth century. But, with only primary batteries available as a source of current energy, an economical solution of the problem which should bring the light into general use as an illuminant was impossible, and although some excellent lamps were produced which worked well on battery circuits, their use was confined almost entirely to the lecture room and the laboratory. With the development of the dynamo machine the conditions were profoundly changed, and the number of different lamps invented during the last thirty years has been legion. In this section of the book we shall briefly refer to the earlier and now historical lamps, leaving to the later section the description of some of the modern lamps and their adaptation to general purposes of illumination.

Reference has already been made to Davy's exhibition of an arc light in 1810 at the Royal Institution, when to obtain the necessary current he used a battery of 2,000 cells. Foucault (1844), instead of using charcoal enclosed in a vacuum, as Davy did, made use of carbon from the retorts of gasworks, which is much harder, and consequently not so soon consumed. Deleuil made use of Foucault's hand regulator to light the Place de la Concorde, Paris; it was placed on the knees of the allegorical statue of the town of Lille, and was, perhaps, the first occasion in which the arc light was used for outside illumination.

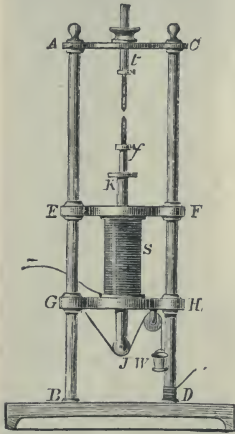

Fig. 215.—Archereau's Regulator.

Previous to 1845, the operations necessary to start the arc and to maintain the carbons at the requisite distance apart were performed by hand. In that year, however, Thomas Wright, of London, devised a lamp in which the adjustment of the carbons was brought about automatically. We have already stated (page 243) that to obtain the arc it is necessary to start a current in the circuit, either by bringing the carbons together or otherwise, and the current having been started, the ends of the carbon electrodes must be kept within a certain distance of each other, either automatically or by the continuous intervention of an attendant. For most purposes the operations of "striking the arc" and of regulating the distance apart of the carbons must be accomplished automatically. Following Wright, W. E. Staite in 1848 used the electric current to adjust the position of the carbons, and Archereau in 1849 constructed the lamp represented in Fig. 215 on the same principle as had been used by Staite and Perie. In Fig. 215, A B, C D and A C consist of copper; *t* is the fixed positive carbon. The solenoid *s* is fastened between the rods E F and G H. To the iron rod *j k* is fastened the negative carbon *t'*. The carbons are pressed together by the cord which passes over the pulley *j* attached to the negative carbon rod, and which is kept taut by

the weight *w*. The current entering by the positive terminal passes up the rod *DC* to the upper positive carbon, thence through the negative carbon to the solenoid *s*, and out by the negative wire. Before the current is switched on, the carbons are in contact and, therefore, the current can pass through. In doing so it energises the solenoid *s* and draws down the negative carbon rod, thus striking the arc, which will continue to burn as long as the distance of the carbons apart is not too great. As the carbons burn away, however, the current, derived from a primary battery in Archereau's time, is weakened, and consequently the pull of the solenoid diminished, allowing the cord and weight to push the carbons closer together, thus "regulating" their distance apart. By careful adjustment it should be possible to keep such a lamp burning for some time.

Passing over various forms of regulating apparatus devised subsequently by Foucault, De Mott, Roberts, Lacassagne, Thiers, and others, some of which will be found described in the earlier editions of this book, we illustrate in Fig. 216 a form of lamp invented by

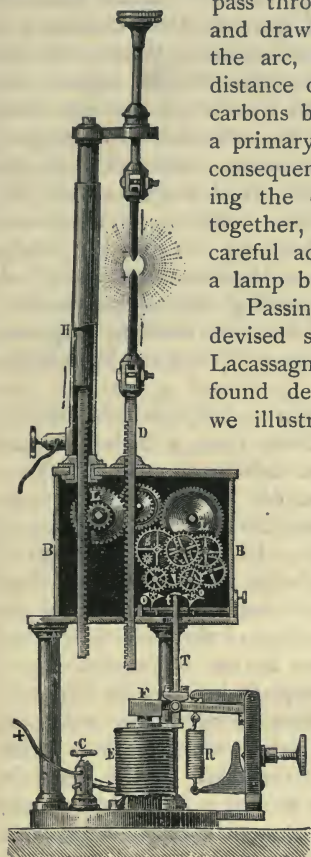

Fig. 216.—Duboscq's Lamp.

Foucault and improved by Duboscq, which is of historical interest, as having been largely used for lectures and laboratory work in conjunction usually with a Grove or Bunsen battery of 50 cells. The box *B B* contains two pieces of clockwork worked by the springs *L'* and *L*. The clockwork *L* terminates in the spur-wheel *o*, and the clockwork *L'* in the spur-wheel *o'*; between these is the catch-pin *τ t*, which will stop or release either. Which of the two clocks is stopped depends on whether the force of attraction of the solenoid *E* or the force of the spring *R* is the greater. By means of the catch *τ t* one or the other clockwork can be stopped. One clock causes the carbon-holders to approach each other, the other causes them

to recede. The wheels are so geared that one of the carbon-holders, the lower one, is made to move twice as fast as the other. The current enters at *c*, flows into the solenoid *E*, through *D*, and leaves the lamp through the upper carbon-holder *H*. When the carbons are at the right distance from each other the forces of the solenoid *E* and the spring *R* are balanced, and *τ t* stands midway between the spur-wheels, stopping both clocks. If the distance between the carbons becomes too great, on account

of the greater resistance, the current diminishes and with it the force of attraction of the solenoid. The spring  $R$  will draw  $T t$  towards the right, liberating the clockwork connected with  $O$ , and causing the carbons to move towards each other. As soon as the right length of the arc is obtained, the solenoid will also have regained its original force of attraction, and will draw the armature again towards itself, causing  $T t$

again to stop both clocks. When the arc is too small, the force of the solenoid increases, and draws  $T t$  towards the left, liberating the clockwork connected with the spur-wheel  $O'$ , which causes a separation of the carbons until the normal length of the arc is obtained. When working on a primary battery circuit the lamp gives a fairly steady light, but the complicated mechanism, and necessity for re-winding the clocks, prevent it being largely used for modern purposes. Moreover, only one such lamp can be inserted in a circuit.

Another excellent lamp, which, besides holding for a long time a high place in lecture-room and laboratory, was the fore-runner of a type which has included many modern lamps, was the lamp first constructed by Serrin in 1859. In this type of lamp the force of gravity moves the carbons, and thus drives a train of clockwork which can be locked by the action of the armature of an electro-magnet as in the Foucault-Duboscq lamp. The lamp is depicted in Fig. 217. The upper positive carbon-holder  $B$  has in its lower section a rack  $A$ , the teeth of which are geared with the teeth of the wheel  $F$ . Upon the same axis as  $F$  is a wheel  $G$ , the radius of which is one-half of  $F$ . From  $G$  a steel chain runs over  $J$  to an ivory piece which is connected with the lower negative

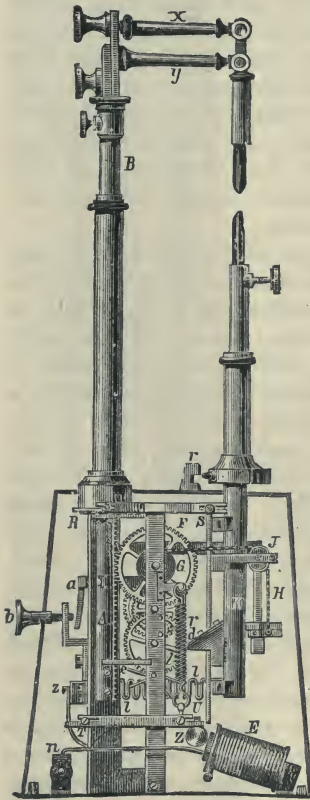

Fig. 217. —Serrin's Lamp.

carbon-holder  $K$ . At the bottom of the lamp case there is an electro-magnet  $E$  of which is fastened to the parallelogram  $RSTU$ .  $RS$  can turn about  $R$ , and  $TU$  can turn about  $T$ . The vertical side  $SU$  is connected with the cross-piece carrying  $J$ . To prevent the parallelogram from being drawn down by its own weight, there are two springs  $r$  (the second is not shown in the drawing), one of which can be adjusted by means of the screw  $b$  and the lever  $a$ . The springs



are so regulated that  $\pi$   $s$  and  $\tau$   $u$  stand horizontally. The last wheel  $e$  forms the star wheel in which the three-cornered click  $d$  catches. When the upper carbon is drawn up, as, for instance, for the purpose of fixing a carbon, the wheel  $\pi$  only will be in motion, the rest of the clockwork being at rest. The arms  $x$  and  $y$  with their screws serve for the exact adjustment of the upper carbon. The current flows through the metal portions of the lamp into the carbon-holder  $b$ , through the carbons to  $\kappa$ , through the spiral  $l$  to the clamp  $z$ , which is connected with the electro-magnet  $E$ . When a current passes through the lamp,  $E$  attracts its armature  $z$ , and the side  $s$   $u$  of the parallelogram descends and carries with it the lower carbon-holder. The upper carbon-holder  $b$  is raised by means of its connection with the wheel  $\pi$ . The carbons are thus separated and the arc struck. In spite of its weight, the upper carbon-holder cannot fall on the lower, as the click  $d$  catches in the spur wheel  $e$ , and arrests the clockwork.

The resistance increases with the consumption of the carbons, and as the current becomes weaker so the electro-magnet becomes weaker. The springs, therefore, come into action, and pull the parallelogram upwards, causing the click  $d$  to be raised and the clockwork to be liberated. The carbon-holder  $b$  now sinks, and  $G$  is turned by means of the wheel  $\pi$ ; the chain  $h$  raises the lower carbon-holder  $\kappa$ , *i.e.* the two carbons are brought near to each other once more.

The Serrin lamp was modified in details by various inventors, more especially by Lontin, who placed the regulating magnet as a shunt across the carbons instead of in series with them.

**Electric Candles.**—In connection with this section of the subject we must refer to a totally different method of fulfilling the conditions, which, though not brought out till 1876, has now only an historical interest. We refer to the so-called "electric candles," in which the length of the arc is not kept constant by any mechanism, but is fixed once for all by the method of construction. The first commercially practical candle was constructed by Paul Jablochhoff in the year 1876. Werdermann was, however, his predecessor, the invention of the latter, although he did not intend it for electric lighting, but to serve as a kind of borer for rocks, being constructed on the same principle. Werdermann allowed an arc to form between two carbons parallel to each other, but separated by a layer of air, and he then caused a current of air or steam to pass between them. The effect was similar to that produced by a blow-pipe, but of such high temperature that in a few hours the hardest granite was fused. The air blast here took the place of the electro-magnet depicted in Fig. 235.

**The Jablochhoff Candle.**—The candle invented by Jablochhoff consisted of two parallel carbon rods  $a$   $b$  (Fig. 218), separated from each other by a layer of plaster-of-Paris; the lower portions of the carbons had short brass tubes fastened to a plate  $h$ , against which two metal

springs *e* and *g* pressed, and the current was conducted through the latter into the candle. A thin plate of graphite *c*, which served to light the candle, was laid across the two carbon points, and held in position

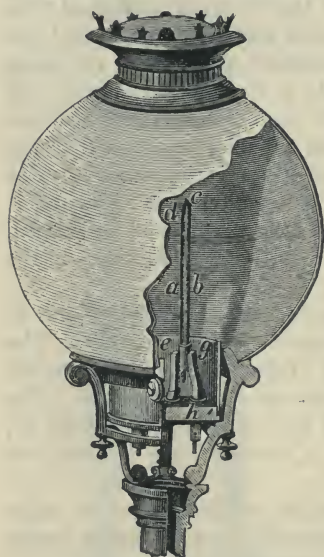

Fig. 218.—Jablochhoff's Candle.

by a paper band *d*. When the candle was inserted in the circuit a current passed from one of the carbon rods through the connecting piece at the top to the second carbon rod, and then back again to the source of electricity. The connecting piece became heated, and after it had been volatilised, the arc formed between the two carbon rods. As the carbons were consumed the insulating layer fused and volatilised. Since the positive carbon is consumed twice as quickly as the negative, it must have twice the cross section of the negative. This proportion is, however, not exact, and as all candles are not consumed at exactly the same rate, alternating currents had to be used. A candle, the carbon rods of which had a cross section of 0.006 square inches, and a length of from 8.8 to 9 inches, burnt about 1½ hours, producing a light of 100-candle power. Several candles could be inserted in one circuit, the light intensity

of the sum of the candles being greater than that of a correspondingly large single candle. The reason of this was that not only was the voltaic arc between the two carbons luminous, but also the volatilising substance between the carbons. When from two to five candles were inserted in one circuit, by turning a commutator one candle after another could be lighted. This arrangement was very inconvenient, and if one of the candles went out from some cause, all the other candles in the same circuit went out too, and could only be relighted by turning their respective commutators. To prevent this there were invented various ingenious automatic devices, which will be found described in the 1893 edition of this book.

Instead of using solid insulating substances some inventors, notably Wilde, Morin, and others, used air, and made one or both the candle rods movable. The drawback of the air insulation is that if the carbons are parallel the arc may travel up and down the gap in an erratic manner. Morin got over the difficulty by slightly inclining the carbons, so that they were nearest together at the points. Jamin employed a very ingenious device; he set the carbon pencils parallel, but surrounded them with a solenoid, the magnetic field of which forced the arc towards and kept it at the points, the action being similar to that of the magnet in Fig. 223.

The light given by these electric candles is much less than that given by an ordinary arc lamp; this combined with the necessity for using alternate currents and the disadvantages resulting therefrom have prevented this form of electric illumination from making headway commercially.

#### VI.—EFFICIENCY OF SOURCES OF LIGHT.

Having now described the two chief methods of applying the electric current for the production of artificial illumination, it will be interesting to turn aside for a moment to inquire how much of the energy used for the purpose really appears as visible light and how much is wasted in other directions. In short, what is the *efficiency* of these and other methods of producing light? For this purpose we may regard the energy supplied to the lamps as ultimately changed into radiant energy, and enquire what proportion of the energy radiated is within the range of vision; all lying outside this range is useless for purposes of illumination. In adopting this method we neglect some other sources of loss, which, however, are not considerable.

It should be explained here that all radiant energy, as such, is in the form of wave motion, and that the particular waves we are dealing with here travel with the velocity of light, or at a speed of 186,000 miles per second *in vacuo*. Now the waves are not all alike, though they travel with the same speed; there are large waves, small waves, and intermediate ones, and to distinguish between them it is most convenient to identify them by their *wave-lengths*, that is, by the distances between successive crests. In any beam of radiant energy there may be mixed together, in what would appear to be inextricable confusion, waves of many different wave-lengths, the whole forming a disturbance of exceeding complexity in the transmitting medium. Fortunately, the methods of spectrum analysis allow us to separate the different components from one another, and give us in the *spectrum* a band of radiant energy, each portion of which has a definite wave-length. Everyone is familiar with such a spectrum in the rainbow. Now when a similar coloured spectrum is produced artificially and measurements made, two or three points come out strongly. In the first place, the wave-lengths are exceedingly small (ranging between about 39 and 78 millionths of a centimetre: *i.e.* 15.5 and 31 millionths of an inch), and are all comprised within about a single octave of vibrations; in the second place, we find that radiant energy, producing no impression on the retina of the eye, exists outside the limits of the visible spectrum and can be detected by other methods, such energy having wave-lengths both longer and shorter than those above quoted.

The distribution of the energy in the spectrum of the electric arc has been investigated by Langley, whose results are embodied in the curve given in Fig. 219. In this curve the horizontal distances represent wave-lengths in



thousandths of millimetres, and the vertical distances represent the corresponding energy. The two dotted vertical lines represent the practical limits of the visible spectrum, and only the portion of the curve between

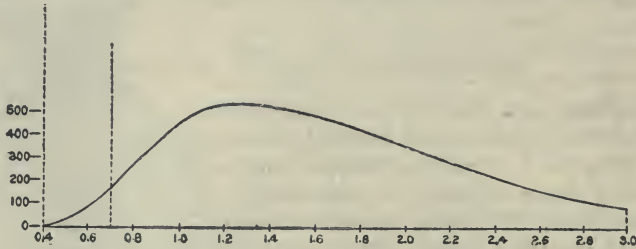

Fig. 219.—Energy Curve. Electric Arc Spectrum.

these lines represents the energy which is usefully employed in giving light. This energy is about  $\frac{1}{31}$  of the whole, and therefore only about 3.2 per cent. of the energy radiated by the arc lamp experimented with is available for purposes of illumination. We may therefore say that the light efficiency of this arc is 3.2 per cent.

Professor Langley gives for comparison the corresponding curves for a gas flame and for sunlight. In each case the total area of the curves is made the same in order to facilitate comparisons. The curve, Fig. 220, for

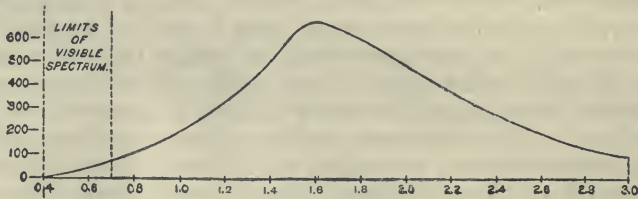

Fig. 220.—Energy Curve. Gas Flame Spectrum.

the gas flame shows that the light efficiency of this source of artificial illumination is only 1.5 per cent., the area between the dotted lines being one sixty-seventh part of the whole. The light efficiency of the electric glow lamp probably lies between that of the arc lamp and the gas flame, but usually nearer to the latter than the former. In the solar spectrum (Fig. 221) the light efficiency is 15 per cent., which is considerably higher than either of the two preceding.

The most curious result of Langley's researches is given in Fig. 222, which represents the spectrum of the fire fly similarly treated. In this case the whole of the radiations are comprised within the limits of the visible spectrum, and the light efficiency is 100 per cent. Only part of the figure

can be given, for in order to represent it on the same scale as the other figures the highest ordinate would have to be 8,700, or over 20 times the

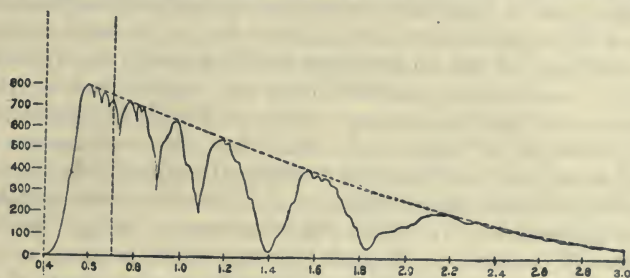

Fig. 221.—Energy Curve. Solar Spectrum.

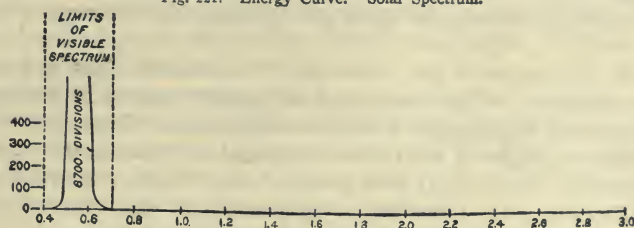

Fig. 222.—Energy Curve. Firefly Spectrum.

highest ordinate in Fig. 219. The result is very interesting, for if we could produce the light of the firefly on a large scale, the whole of the energy radiated would be available for illumination. Professor Langley considers that such production is not impossible, as vital processes do not seem to be essential to it.

#### VII.—PHYSICS OF THE ELECTRIC ARC.

Although the electric arc was discovered by Davy in 1802, the complex physical problems presented by it have only received the attention they deserve within the last few years. We are still far from having reached finality in the investigation of these problems, and many results at present tentatively accepted will doubtless have to be revised. In what follows we shall endeavour to indicate the chief problems and some of the methods employed in attacking them, together with the most important of the results obtained. We begin with the older experimenters.

If we suddenly stop the current, we find the positive electrode white-hot, whilst the negative is hardly red-hot. If we produce an arc between mercury and a wire, and when the wire is the positive pole, we find that the wire will be white-hot a good distance up; if, on the other hand, the mercury be the positive pole, the wire remains dark, and the mercury becomes heated and evaporates. These experiments and others show, then, that different quantities of heat are generated at the two poles; the

positive electrode being at a considerably higher temperature than the negative electrode. Rosetti found the temperature between the two carbon points from  $2,500^{\circ}$  to  $3,900^{\circ}$  C. ; the positive electrode was at about  $2,400^{\circ}$  to  $3,900^{\circ}$ , and the negative from  $2,138^{\circ}$  to  $2,530^{\circ}$  C. The statement, that one of the advantages of the electric light lies in keeping the space where it is employed comparatively cool, is in no way contradicted by the above temperatures ; for the heat-giving surface of the electric light, compared with other sources of light, is so small that the total amount of heat generated by an electric light would be far less than that from other sources. Siemens found that an electric light of 4,000 candle-power produces 142.5 heat units per minute. To obtain the same amount of light by means of gas we should require 200 Argand burners, which produce 15,000 heat units. The electric arc, therefore, produces about 1 per cent. of the heat which would be produced by good gas lights giving the same quantity of light.

For the comparison of the intensities of the electric light and sun light, rays of each source of light were first collected by means of convex lenses, and then allowed to act upon a Daguerreotype plate. The times were compared which the light of each source required to produce the same effect. The intensities of the lights were then taken inversely proportional to the times. This is only, however, a comparison of the effective so-called chemical or more refrangible rays, the electric light being relatively richer in these than sun light ; the proportions given are, therefore, not correct.

An examination by the methods of spectrum analysis of the light of the arc itself, as distinct from that of the flowing positive crater, leads to some interesting results. It is well known that if different substances in the form of vapour be made to glow, and then the light which the vapours send out be examined, each substance has its characteristic spectrum. When the electric arc is examined in this manner, the characteristic spectrum for the chemical substance of which the electrodes are made is obtained.

**Striking the Arc.**—The method of starting or, as it is called, "striking" the arc should be noted. After the electrodes have touched each other, and are then separated, there passes a spark whose method of production may be explained as follows : By removing the surfaces that are in contact away from each other we lessen the cross-section of the circuit more and more, until the cross-section becomes so small that the particles still touching each other begin to glow with the heat produced by increased resistance, and are then carried away. When now the two electrodes are separated a very little distance from each other, the glowing particles form a bridge between the electrodes, and the current can pass through this stream as a conductor, although a bad one. The tearing off of the particles, once commenced by the spark, continues, and will be the more easily maintained the more easily the electrode particles can be torn off ; in other words, the more readily the material of the electrode volatilises the farther may the electrodes



be separated from each other. If, however, the distance is increased beyond a certain limit the particles are no longer capable of flying from the one electrode to the other, and the current is interrupted; the arc dies out, and can only be lighted again by bringing the two points together. Le Roux found that the current might be interrupted for not more than one-twenty-fifth of a second without the light dying out.

**Resistance of the Arc.**—The measures obtained by early observers for the resistance of the arc varied very much, but the cause of the discrepancy will be found in the nature and behaviour of the arc itself, which we shall explain farther on. Experiments show that the resistance does not entirely depend upon the length of the arc, and therefore there must be another agent which helps to weaken the current. This agent can be shown to be an E. M. F. which is generated in the arc, and opposes the current that produces the arc. This opposing E. M. F. has been frequently measured as resistance, and is one of the chief causes that such different results have been obtained.

Early experimenters endeavoured to measure the resistance of the arc in the same way that one would measure the resistance of a metallic wire, namely, by measuring the potential difference required and the current produced between the carbons. Making use of Ohm's law in its usual form, the resistance would be given by the equation

$$\text{Resistance} = \frac{\text{Potential difference (P. D.) of carbons}}{\text{Current through arc.}}$$

A proper allowance being made for the resistance of the carbon rods themselves, the remaining resistance should be that of the arc alone. If this remaining resistance is of the same nature as ordinary resistance, it should follow the laws already given (*see* page 188), and more particularly should be proportional to the *length* of the arc. Edlund and others, however, have shown that when experiments are thus made with arcs of different lengths the resistance is not proportional, but that the relation between the resistance ( $R$ ) and the length ( $l$ ) of the arc is expressed by the equation

$$R = a + bl \quad (1)$$

where  $a$  and  $b$  are constants when the current and other conditions of the experiment are kept unchanged. In other words, the so-called resistance depends upon two terms, one of which ( $bl$ ) is proportional to the length of the path, and the other ( $a$ ) is constant.

To examine the nature of the results more closely, let each term of equation (1) be multiplied by the current ( $c$ ) used in the experiment, thus:

$$Rc = ac + blc. \quad (2)$$

The term ( $Rc$ ) on the left hand side will now be the potential difference ( $v$ ) originally measured, whilst of the two terms on the right hand side the second should indicate the voltage necessary to overcome the true

resistance of the arc, and if we put  $bl = r$ , this term may be written  $r c$ . The first term,  $a c$ , is constant if  $c$  be constant, and its presence in the equation indicates the existence of an actual electrical pressure or E. M. F. in the arc, against which the applied P. D. has to drive the current. Calling this  $E (= a c)$ , our equation finally becomes

$$V = E + r c. \quad (3)$$

In deducing this equation it must be remembered that Edlund's experiments were made with a constant current, and that he found that the quantities  $a$  and  $b$  in equation (1) were affected by the value of the current used. If, however, the arc consists electrically of a back E. M. F. in series with a true resistance, equation (3) should represent the facts, though it is conceivable that the resistance may vary with every change in the conditions, even as the resistance, within much narrower limits, of a metallic wire varies.

Some experiments published by Frith and Rodgers in 1896 were interpreted by the authors as proving a *negative* resistance in the arc. This interpretation, however, has been very strongly objected to both on general grounds and also as incorrectly representing their results.

**E. M. F. in the Arc.**—Edlund proved directly the presence of an opposing electromotive force. The current that produced the arc was suddenly interrupted (it has been stated that the arc does not die out immediately after the current ceases), and

at that moment a galvanometer was connected with the two carbons. The deflection of the needle was regarded as indicating the opposing E. M. F.\*

As it is of some importance to locate the seat of this E. M. F., subsequent experimenters, notably Lecher, S. P. Thompson, and Mrs. Ayrton, have examined the phenomena more minutely by using a third, or exploring, electrode for finding the distribution of the pressure in various parts of the arc, and more especially the P. D. between the  $+$ <sup>ve</sup> carbon and the arc and the P. D. between the arc and the  $-$ <sup>ve</sup> carbon.

Dr. Fleming, as early as 1890, in his experiments on the "Edison Effect" in glow lamps (page 238), extended his observations to the electric arc, using the apparatus shown in Fig. 223, in which the third or exploring electrode is seen on the right of the arc connected through a galvanometer  $G$  to the upper or  $+$ <sup>ve</sup> carbon. As his exploring electrode was rather thick, he found it convenient to deflect the arc by bringing a magnet  $N S$  near it as shown. The result of the experiment was that when the second

\* Blondel, however, repeating this experiment with more elaborate apparatus in 1897, was unable to find any trace of an E. M. F. within  $\frac{1}{250}$ th of a second after the cessation of the current.

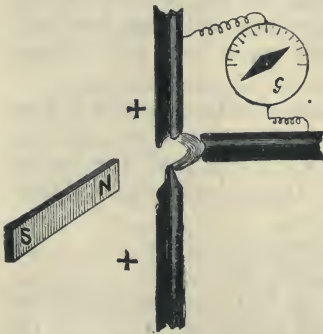

Fig. 223.—Dr. Fleming's Experiment with the Electric Arc.

terminal of the galvanometer was joined as shown to the  $+$  carbon a large current was observed, but Dr. Fleming failed to observe a current under these conditions when the second terminal was joined to the  $-$  carbon. To measure the P. D. accurately, however, it is necessary to bring the exploring electrode very close to the carbon (theoretically it should be infinitely close) without touching the latter, a condition very difficult to attain because of the action of the high temperature on the materials available; in fact, no conducting material has yet been found which will resist the high temperature in the positive crater. The measurement is made by connecting the exploring electrode to the terminal of a high resistance galvanometer, the other terminal of which is joined either to the  $+$  or the  $-$  carbon as in Dr. Fleming's experiment.

*Mrs. Ayrton's Experiments.*—

The various and complicated problems connected with the physics of the electric arc and the practical working of arc lamps were most assiduously studied for several years by

Mrs. Ayrton at the Central Technical College in London. One of the objects of her researches was to find the law connecting the various potential differences, the current, and the length of the arc, other minor variables, however, not being overlooked, especially some which have a great influence on the practical application of the arc for purposes of illumination. In regard to the particular problem we are now discussing, Mrs. Ayrton in 1895, after a careful and laborious examination of a great number of experiments, published the following equation as embodying the results and as true for the particular kind of carbons used in the experiments:

$$v = 38.88 + 2.074l + \frac{11.66 + 10.54l}{c} \quad (4)$$

in which  $v$  is the potential difference between the carbons measured in volts,  $c$  is the current measured in amperes, and  $l$  is the length\* of the arc measured in millimetres.

\* In this and the subsequent similar equations the expression "length of arc" is used in a somewhat artificial sense, and must not be taken literally. On account of the difficulty, if not impossibility, of a direct measurement, a magnified image of the arc is usually projected on a screen, and the vertical distance between the two horizontal lines  $ab$  and  $cd$  (Fig. 224) measured. The line  $ab$  is drawn through the projected edge of the crater, and  $cd$  through the tip of the negative carbon. This vertical distance between the two lines is the quantity denoted by  $l$  in the equations. The actual mean length of the arc is greater both because of the hollow of the crater lying behind  $ab$ , and also because  $cd$  is drawn through the point of the negative carbon nearest to the positive carbon.

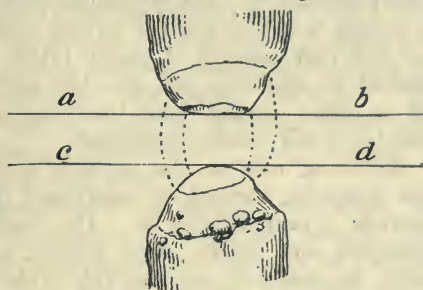

Fig. 224.—Measurement of Arc Length.



Comparing this equation with equation (3) we see that the term  $\epsilon$  of the former equation is represented by the term 38.88 (volts) in the latter, and this may therefore be taken as the true back E. M. F. of the arc for the particular kind of carbons used in the experiment. The absence from (4) of any term corresponding to the term  $r c$  of (3) would seem to show that there is no true resistance in the arc. Such a resistance, however, has been directly measured by Von Lang and subsequent experimenters, using Wheatstone bridge methods, in which proper account is taken of the back E. M. F. Considerations of space will not allow us to describe in detail these and other interesting experiments, including those of Frith and Rodgers already referred to. The remaining terms of equation (4) show that there is (i.) a back E. M. F. of 2.074  $l$  varying with the length of the arc, and (ii.) that a further amount of power (11.66 + 10.54  $l$  measured in watts) is required to maintain the arc, the power consisting of a constant term and a term varying with the value of  $l$ . The physical meaning of these terms still awaits explanation.

Returning now to the problem of the seat of the back E. M. F., the most promising method of experiment is the use of a third or exploring electrode already alluded to. This method has been employed by Dr. Thompson and others. Mrs. Ayrton, using fine carbon pencils, obtained results by gradually moving the exploring electrode nearer and nearer to either the positive or the negative carbon, and taking the reading of the galvanometer immediately before actual contact. The results, published in 1898, are as follows:—

$$\text{At the positive carbon } v = 31.28 + \frac{9 + 3.1l}{c} \quad (5)$$

$$\text{At the negative carbon } v = 7.6 + \frac{13.6}{c} \quad (6)$$

If these two equations are added together we get

$$v = 38.88 + \frac{22.6 + 3.1l}{c} \quad (7)$$

an equation showing remarkable coincidences with equation (4), especially in the actual value of the first term. It may be pointed out that the conditions of the working of the arc are disturbed by the presence of the third electrode, and this may account for the outstanding discrepancies between (4) and (7). The interesting points in connection with equations (5) and (6) are (i.) that of the total back E. M. F. of 39 volts about four-fifths is located at the passage of the current from the positive carbon to the arc and about one-fifth at the passage from the arc to the negative carbon, and (ii.) that the E. M. F. at the negative carbon is a *back* pressure and not one in the direction of the current, thus showing that whatever its physical explanation may be, the predominant cause is not

the condensation of carbon vapour on the electrode, for this would throw back energy into the circuit and give rise to a forward E. M. F. Some experimenters assert they have detected such a forward E. M. F. at the negative carbon; all Mrs. Ayrton's measurements, however, show the contrary.

By an elaborate discussion of the results of previous experimenters, Mrs. Ayrton is led to the conclusion that equation (4) may be generalised in the form:—

$$v = a + bl + \frac{c + dl}{c} \quad (8)$$

where the co-efficients  $a$ ,  $b$ ,  $c$  and  $d$  are constant for the same kind and quality of carbons, but vary slightly as the carbons are changed; it is true for solid carbons only, with cored carbons the data are more complex.

It is interesting to note that when metallic electrodes are used the value of the back E. M. F. is less than with carbon electrodes. Von Lang found the value to vary from 27 volts for platinum to 10 volts for cadmium, the intermediate metals experimented upon arranged in order being nickel, iron, copper, zinc, and silver.

On the assumption that the temperature of the arc is constant, and that of the boiling or volatilisation point of the negative terminal, and that the energy used up in the arc, apart from that radiated by the electrodes, is radiated from the surface of the arc stream, Steinmetz argues that the power radiated per unit surface of that stream may be assumed to be constant. On the further assumption, the reasons for which will be dwelt upon later, that the section of the arc stream is proportional to the current, he deduces a voltage equation for the arc. Thus if  $v$  be the voltage consumed in the arc stream as distinct from the voltage drop at the terminals,  $d$  the diameter, and  $l$  the length of the stream, and  $c$  the current, we have:

$$v_1 c = \text{radiation} \propto dl \quad (1)$$

$$\text{also} \quad c \propto d^2, \text{ or } d \propto \sqrt{c} \quad (2)$$

$$\text{Therefore} \quad v_1 c \propto l \sqrt{c}$$

$$\text{or} \quad v_1 \propto \frac{l}{\sqrt{c}}$$

or, since some energy is taken from the stream by the electrodes,

$$v_1 \propto \frac{l + c}{\sqrt{c}}$$

where  $c$  is a small constant quantity.

The final equation, therefore, is:

$$v = v_0 + \frac{a(l + c)}{\sqrt{c}}$$

where  $a$  is a constant and  $v_0$  is the voltage, representing the back E. M. F. at the electrodes due to the energy changes taking place there.

As a result of experiments, Steinmetz gives the values of the constants as follows :

$$v = 36 + \frac{5.1(l + 8.5)}{\sqrt{c}} \text{ for the carbon arc,}$$

$$v = 30 + \frac{4.85(l + 1.25)}{\sqrt{c}} \text{ for the magnetite arc,}$$

the length  $l$  being measured in millimetres, as in Mrs. Ayrton's experiments. No information is given as to the carbons used in the experiments; magnetite is magnetic iron ore ( $\text{Fe}_3\text{O}_4$ ), a substance which has been used to replace carbons in arc lamps.

For the mercury arc the conditions are more complex, since the cross section being constant (the arc being enclosed in a tube), the pressure and the temperature must vary with the current. Analysing these conditions, Steinmetz deduces the equation :

$$v = 13 + \frac{l}{42.6 d - 1.67 c - \frac{33 d^2}{c}} \text{ with a solid anode,}$$

$$v = 13 + \frac{l}{42.6 d - 2.9 c - \frac{33 d^2}{D}} \text{ with a mercury anode,}$$

the symbols having the same meanings as before.

**Source of the Back E. M. F.**—If the presence of an E. M. F. in the arc be proved, it becomes important and interesting to examine the physical facts underlying it. Whenever a current is forced against an E. M. F. energy is taken out of the circuit, and some kind of work is done at the place where the E. M. F. exists, the amount of the energy so expended per second being measured by the product of the current and the E. M. F. Recurring to the somewhat similar case of the voltameter (pages 200 and 201), the energy taken out of the circuit is employed in splitting up the electrolyte into its constituents, and the value of the back E. M. F. in volts can be calculated from the chemical work done. In the voltameter this back pressure is of the order of one or two volts. The first difficulty which meets us in the case of the electric arc is the magnitude of the back E. M. F., which is, as we have seen, about 40 volts. Closely bearing upon this question is an observation of Abney's, subsequently confirmed by Professor J. Violle, that the white light emitted by the positive carbon has always the same composition, from which we may infer that the temperature in the crater has a certain definite and constant value. Such constant values of temperature usually denote that some physical change is in progress, as, for instance, when ice is melting or water is boiling under a constant pressure. The most obvious change of this nature that can be taking place is *the volatilisation of the carbon*, and it is therefore fair to assume that, at least as far as the positive carbon is



concerned, the greater part of the back pressure may be due to this cause. There has been some question as to whether the volatilisation takes place by direct evaporation or by ebullition. Blondel, who has made numerous experiments on the physics of the arc, considers that he has proved that the former is the case. Against the explanation that the E. M. F. is due to volatilisation must be placed the experiments of Wilson, who in 1895 examined the effect of pressure on the arc. He found that as the atmospheric pressure increased the brightness of the positive crater is diminished, until at a pressure of about 20 atmospheres (about 3,000 lb. per square inch) the brilliancy fell to a dull red colour. He therefore concludes that the temperature of the crater cannot be that of boiling carbon, for if it were we should expect the temperature, and therefore the brilliancy, to increase with increase of pressure.

An examination of the shape of the carbons under different conditions gives some insight into the phenomena. These shapes are found to vary, as might be expected, with the physical condition of the carbons themselves, whether cored or solid, hard or soft, conditions which also affect the size, colour, and form of the visible part of the arc. In addition, the precise shape which the carbon points assume after a period of steady burning in the open air depends on the length of the arc and the magnitude of the current. There is always a crater at the end of the positive carbon, and the negative carbon is always more or less pointed (see Fig. 214), but the exact shape and size of the crater and the shape of the point vary with each variation of conditions. These minute changes we have not space to describe, but it may be said generally that they afford conclusive evidence that there is volatilisation of carbon in the crater, and that carbon is carried over and deposited on the negative electrode. The negative carbon also becomes more pointed the larger the current and the shorter the arc. Why the carbons do not burn away more rapidly in an atmosphere containing oxygen is partly explained by the excessively high temperature attained, which is probably above the temperature at which carbon and oxygen can combine to form carbon monoxide. On the cooler parts of the carbons some actual burning occurs, but the rate of burning is slow, and the carbons rapidly cool to blackness when the current is interrupted.

**The Flame Arc.**—The appearance of the arc shown in Fig. 214 is that of an arc passing between the ends of carbon rods placed co-axially in a vertical line with the positive carbon at the top, and therefore with the current passing vertically downwards. From what has been said, it will be gathered that the greater part of the illumination is due to the intensely bright surface of the positive crater, which is cup-shaped, and that therefore, as the cup of the crater is directed downwards, it is in the direction that the greatest intensity of illumination should be found. But

it is exactly in this direction that the mass of the negative carbon blocks the transmission of the light from the crater, with the result that a large quantity of the emitted light is intercepted and the line of maximum illumination is inclined to the vertical line at an angle which varies with the length of the arc, but is usually about 50 degrees. Moreover, the light from the crater has to pass through the parti-coloured mist or arc, which absorbs some of the light, and thus reduces the total illumination. Owing to this absorption it is not economical to lengthen the arc beyond a certain limit, which Mrs. Ayrton has found to be between 3 and 4 mm. for the vertical type of arc.

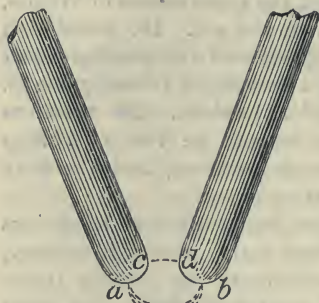

Fig. 225.—Inclined Carbons for Flame Arcs.

formed not on the part of the positive carbon rod nearest to the negative carbon, but on some less shielded part. After much experimenting, a type of lamp, which will be more fully dealt with in the technical section, has been evolved, in which the carbons are inclined to one another in a vertical plane, as shown diagrammatically in Fig. 225, the arc being formed between the lower tips of the carbons *c* and *d*, where they approach one another.

In order that the arc may take the longer path shown by the dotted lines between *a* and *b*, instead of forming between the nearest points *c* and *d* of the carbon rods, two conditions must be fulfilled. In the first place, the voltage must be sufficiently high to maintain the longer arc, being something like double that required for the short vertical arc; and, secondly, the arc must be forced to take the longer path. This latter condition can be attained by placing the arc in a

If, however, the carbons are not coaxial, the shading effect of the negative carbon will be diminished and may be altogether eliminated if only the crater be



Fig. 226.—Pure Carbon Arc. (Length, 1.15 mm.)

formed not on the part of the positive carbon rod nearest to the negative carbon, but on some less shielded part. After much experimenting, a type of lamp, which will be more fully dealt with in the technical section, has been evolved, in which the carbons are inclined to one another in a vertical plane, as shown diagrammatically in Fig. 225, the arc being formed between the lower tips of the carbons *c* and *d*, where they approach one another.

horizontal magnetic field, in which it will behave as a flexible conductor and be forced in a direction at right angles to the current and the field, in accordance with the laws of electro-magnetic action, which will be explained later.

The different effects procurable are well shown in Figs. 226, 227, and 228, which are taken from a paper on "Long Flame Arc Lamps," read by Mr. Leonard Andrews before the Institution of Electrical Engineers in April, 1906. In Fig. 226 we have the inclined carbons at a P. D. of 56 volts, at which the arc is formed in the narrow space between the carbons, and the crater is turned towards the negative carbon as in the ordinary co-axial arrangement. In Fig. 227 the P. D. has been increased to 78 volts and the arc driven to take a longer path, in this case 10 mm., so that the positive crater is no longer turned directly towards the negative carbon, but is



Fig. 227.—Pure Carbon Arc. (Length, 10 mm.)



Fig. 228.—Pure Carbon Arc. (Length, 15.5 mm.)

so situated that the greater part of its light can be freely radiated without obstruction. By raising the P. D. still higher, to 94 volts, the arc is formed directly between the tips of the two carbons, as shown in Fig. 228, in which the length of the arc is 15.5 mm. Illustrations of the effects at intermediate voltages will be found in the paper.

#### The Chemical Flame Arc.—

The arcs, whether vertical or flame, hitherto described as formed between pure hard carbons, have a white light approximating in quality to daylight, but somewhat more bluish or violet, because of the light emitted from the gaseous envelope. A complete change takes place in the character of the light if foreign bodies which can be raised to incandescence are introduced into



this gaseous envelope by impregnating the carbons or their cores with metallic salts, such as the salts of calcium and magnesium, which are most usually employed. The temperature of the arc being very high, these salts become dissociated when thus introduced into it, and the dissociated calcium, magnesium, strontium, or other metal, as the case may be, glows incandescent, emitting its characteristic light, which students of the spectrum know is different for each metal, and which has long been used in pyrotechnics producing coloured fires. Thus it is possible to impart to the gaseous envelope a reddish tinge or a warm, mellow colour, and therefore to alter completely the character of the light. Moreover, the effect produced is, to a great extent, under control, and can be adapted to the particular purpose for which the illumination is required. The one thing, however, which cannot be done with such lights is to use them for matching colours.

It is curious to note that when the metallic salts referred to are present in the carbons, the area of the crater is usually considerably less than with a pure carbon arc burning with the same current. In fact, the proportion of light emitted by the carbons and by the flame is entirely changed, and the latter becomes much more important, although its intrinsic brilliancy is very much less than that of the crater. Its area, however, being very large, the total light emitted is often greater than that from the pure carbon arc, even when the latter is of the flame type. Another peculiarity is that the voltage necessary to maintain the long arc is considerably less when chemicals are employed, being only about 40 to 50 volts. This is partly due to the lower resistance of the arc proper, but there are other causes for the low voltage.

**Enclosed Arcs.**—The rate at which the carbons consume is very much diminished by enclosing them in a space into which the air leaks but slowly. This slow rate of consumption of the carbon is one of the principal objects

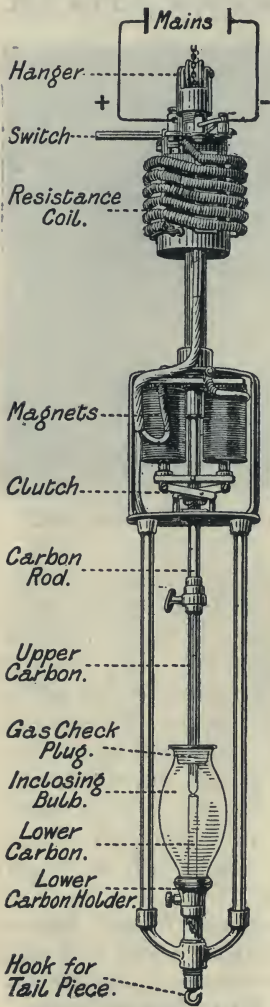

Fig. 229.—The Marks Enclosed Arc Lamp.

of the "enclosed" arcs, introduced during the last decade of the nineteenth century. The general arrangement of the parts of such a lamp, as used on an 80 to a 100 volts circuit, is clearly shown in Fig. 229. The current is led in from the positive main through a switch at the top of the lamp, whence it passes through a steadying resistance coil to the electro-magnets, which control the striking and feeding mechanism; it then passes through the carbon-holder to the upper carbon. The latter passes loose-tight through the special plug in the upper of the enclosing bulb within which the arc is formed, and which contains the lower carbon and its holder; from the latter the current returns by the frame of the lamp to the negative main terminal.

The enclosure with the special plug used in the Marks lamp, which is the lamp illustrated in Fig 229, is shown on a larger scale in Fig. 230. One of the difficulties at first met with in working enclosed arcs was the blackening of the inside of the enclosing glass owing to the deposition of carbon upon it. This deposition was supposed to be due to some of the carbon vaporised at the positive electrode getting away from the arc and not finding oxygen to combine with before it cooled down below the temperature at which the combination takes place. On the other hand, a large excess of oxygen leads to a comparatively rapid consumption of the carbons. The gas-check plug (Fig. 230) was devised to regulate the amount of oxygen; the metal tube through which the positive carbon passes contains a little hollow chamber about  $\frac{1}{2}$  inch long, access to which from the enclosure is obtained through slots in the side, and from the outer air through a small opening which will be seen on the left-hand side of the carbon rod. The proper rate of flow of the gases into and out of the bulb depends on the care with which the details of this "dead-air" chamber, as it has been called, are worked out.

As a rule, the length of the arc used in these enclosed lamps is considerably longer than is usual with the ordinary open arcs. The difference in the way in which the carbons form at the electrodes of the arc in the two cases is strikingly shown in Figs. 231 and 232. In Fig. 231

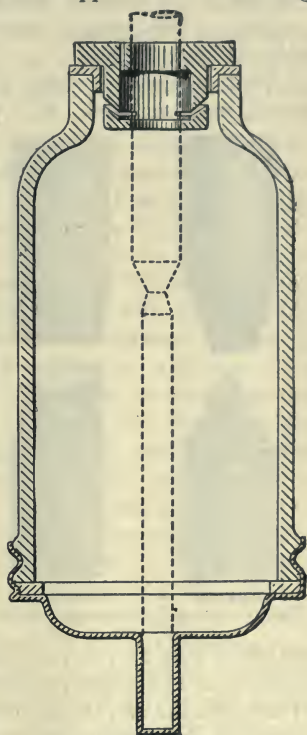

Fig. 230.—Enclosure with Gas-check Plug.

the pair of carbons on the left have the well-known shape of the carbons in the ordinary open arc. The negative is pointed, and the positive begins to taper at some distance back from the crater. The carbons on the right are those of an enclosed arc burning with the same voltage (45 volts) and current (6 amperes) as in the other case. The difference is very marked. The positive is quite blunt, and shows little or no sign of tapering as the crater is approached, whilst the negative, so far from being pointed, has a curious mushroom-like formation on its end. The open arc was 3.5 mm. long, or double the length of the enclosed arc, which was only 1.7 mm. long.

With a higher voltage (85 volts) and the same current the difference is still more marked. The positive carbon of the open arc, as seen on

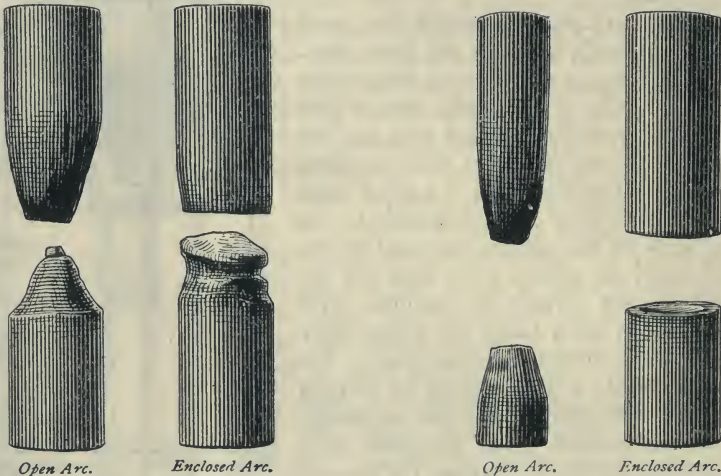

Fig. 231.—Arcs at 6 Amperes and 45 Volts.

Fig. 232.—Arcs at 6 Amperes and 85 Volts.

the left of Fig. 232, is thinned down for a much greater distance from the crater, and the negative carbon is blunter at the tip and also thinned. In the enclosed arc, shown on the right, both positive and negative carbons have their full diameter up to the arc and end almost square. In this case the open arc had a length of 15 mm., and "flamed" continuously, whilst the enclosed arc was only 9 mm. long, and burned quite steadily.

The rate of consumption of carbons 11.11 mm. in diameter in an enclosed lamp with a 5-ampere current is about 2 mm. per hour for both carbons together, more than four-fifths of this amount being at the positive carbon. Thus, with not very long carbons, such a lamp would burn for 150 hours without re-carboning, and therefore would be economical both as regards cost of carbons and of attendance. Owing to the length of the arc there is also an absence of shadows from the carbon points and a more equable distribution of light than in the open arcs.



**Hissing Arcs.**—When either the carbon arc is short for the magnitude of the current employed, or, what is the same thing, when, with a constant length of arc, the current is increased beyond a certain magnitude, a remarkable change takes place, and the physical conditions under which the arc exists appear to be completely altered. The arcs to which we have been referring hitherto burn quite quietly if properly controlled; they may be called "silent" arcs. When, however, the change above mentioned takes place, and during the whole time of continuance of the conditions which have caused it, the arc "hisses" in a very disagreeable manner.

The effect of the "hissing" condition on the electrical measurements is shown graphically in Fig. 233, taken from a paper by Mrs. Ayrton read before the Institution of Electrical Engineers in 1899. The various lines on the diagram show the connection between the potential difference (P. D.) of the carbons and the current for various lengths of arc measured as previously explained (*see note, p. 257*). The P. D. in volts is set out vertically, and the current in amperes is set out horizontally. The length of the arc in millimetres is marked on each line. The concave curves on the left of the bounding line A B C represent the measurements for "silent" arcs, and about them we need only draw attention to the fact that with each *increase* of current there is a *lowering* of the P. D. between the carbons, as must be the case if equation (8), page 259, is true. When, however, with any curve—for instance, the curve for the 2 mm. arc—the current is increased to a value beyond that indicated by the point B, in which the curve cuts the bounding line A B C, the P. D. suddenly *falls about 10 volts* to the point D, and for further increases the voltage *remains nearly constant*. The "hissing" condition with an arc 2 mm. long gives the straight line D F G, in which, although the current changes from 18 to 25 amperes, there is but little change in the P. D.—what little change there is in the direction of a rise as the current increases. The dotted lines to the right of A B C refer to an unstable period in which no measurements are possible; they are merely inserted as connecting links. The diagram given is for solid carbon electrodes, but the same phenomena are shown when cored carbons are used, although the actual readings are different. An increase in the size of the carbons, however, requires a larger current to be used before the "hissing" state supervenes for any given length of arc. It is further worthy of note that although solid and cored carbons give very different curves for the "silent" state, their behaviour in the "hissing" state is identical. In the latter state equation (8) for the "silent" arc no longer holds; its place is taken by the simpler equation:

$$v = a + bI$$

where  $a$  and  $b$  are constants, which for the curves in Fig. 233 have the values

$$a = 29.25, \quad b = 2.75.$$

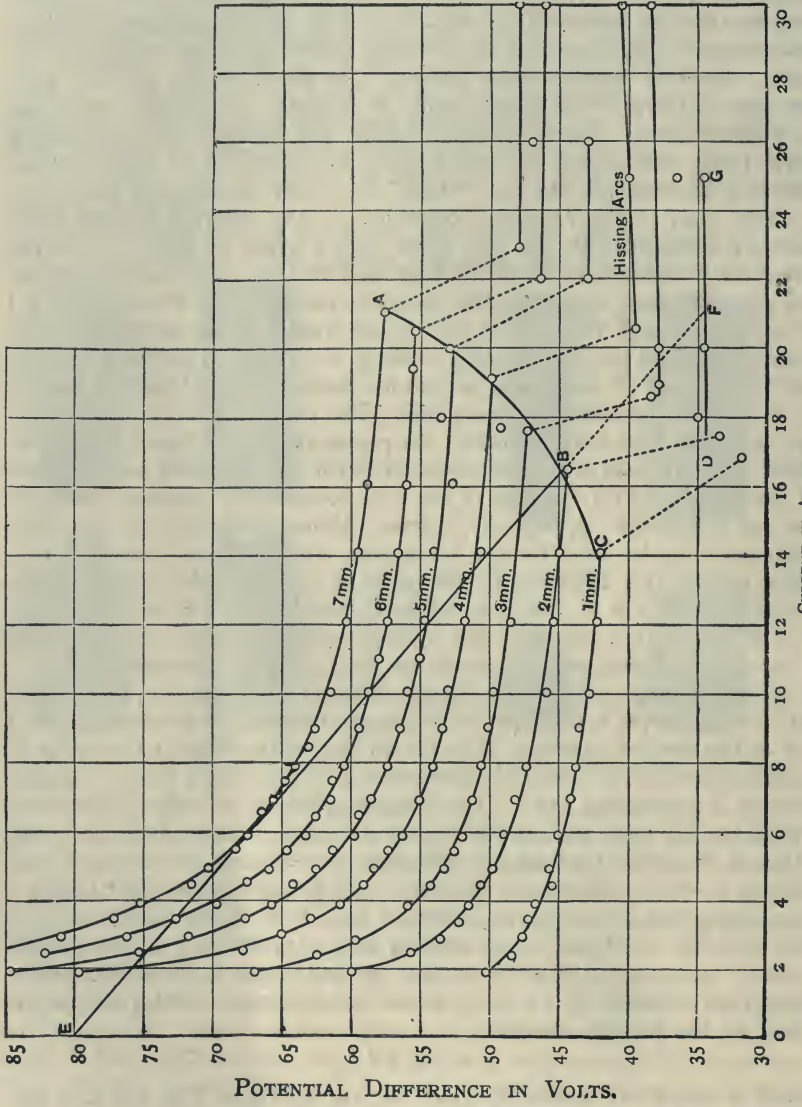

Fig. 233.—Silent and Hissing Arcs.

Besides the hissing and the change in the voltage law, other facts are observed which throw additional light upon the phenomena. In an open "silent" arc the outer sheath of the luminous vapour is always a bright green, whilst the crater is intensely white. In the "hissing" arc the light issuing from the crater is also a bright green or a greenish blue, and the arc spreads out and is flattened between the carbon surfaces. The shape of the carbons also changes, and, as Mrs. Ayrton points out, these changes give the clue to the fundamental physical difference between the two forms of the arc. The changes of the positive carbon are the most important. These are well shown in Fig. 234, also taken from Mrs. Ayrton's paper, and which represents the arc for four different currents, the last being sufficiently large to produce the "hissing" state. In these diagrams, the thick line *BC* is the diameter of the mouth of the crater, and it will be noticed that this diameter increases with increase

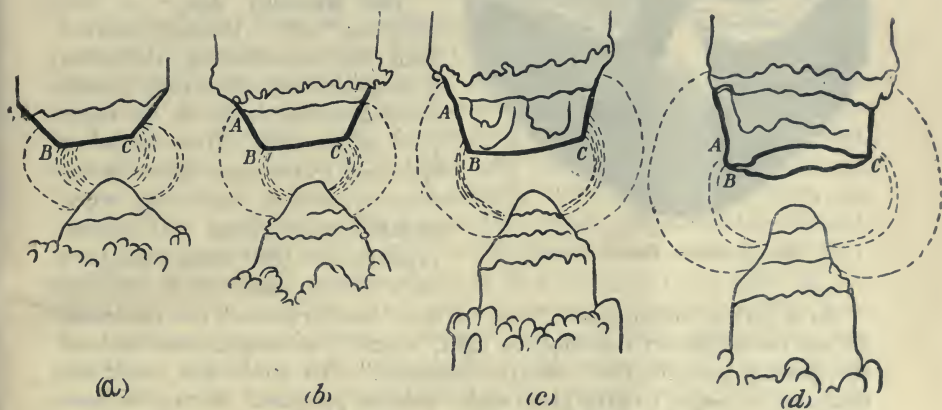

Fig. 234.—Explanation of the Hissing Arc.

of current. In diagrams (a) and (b), for 6 and 12 amperes respectively, the diameter of the crater is much less than that of the carbon rod; in (c), where the current is 20 amperes and the arc is "on the point of hissing," the crater and the rod in its neighbourhood are about equal in diameter. In (d), with a current of 30 amperes, the crater has broken through and, as it were, overflowed on to the side of the carbon. When this happens—that is, when the crater is too large to occupy the end only of the positive carbon, and therefore extends up its side—hissing is always produced. This leads on to the further simple explanation that the sudden changes noted above are due to the air penetrating to the surface of the crater. Whilst the crater was at the end only of the carbon rod this surface was protected by a cushion of vapour, but when the crater comes out at the side the air has easy access to at least a part of its surface, and burning takes the place of volatilisation.



Fleming suggested that the arc is an instance of electrolysis of complex carbon molecules in the gaseous column, and that the velocity of the negative ions is greater than that of the positive ions. This would cause a cushion of negative carbon ions to be formed in the crater, and the presence of this cushion would account for the great fall in potential in passing from the carbon to the gas. When the oxygen of the air reaches this cushion it combines with the carbon vapour, and there is a sudden

lowering of resistance, to be followed almost immediately by a fresh accumulation of ions and a fresh combination, and so on. The fact that the hissing arc is *intermittent* and not continuous supports this view.

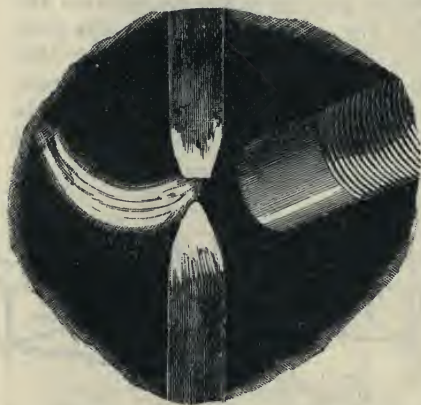

Fig. 235 — Davy's Electric Blowpipe.

**The Mercury Arc.**—In the foregoing “arcs” the light emitted from the incandescent electrodes plays a very important part, though its importance is less in the flame types of arc than in the vertical or open arc. In the flame types, moreover, it is less important when metallic salts, giving off metallic vapours, are used than with pure carbon electrodes.

In a further development, that of the “mercury arc,” the electrodes do not contribute to the effective light, which is altogether derived from the glowing gases of the “electric discharge.” To attain this result the discharge is caused to take place under reduced pressure. So far, we have been dealing with the discharge in spaces surrounded by and exposed to gases at ordinary atmospheric pressure. When this pressure is reduced the phenomena change, and as the “mercury arc” may be regarded as the first step in a complicated series of changes, it will be more convenient to postpone the consideration of the principles involved until we deal with the whole subject in Chapter XVIII.

This sketch, though a mere outline of some of the recent work on the physics of the arc, and in which many workers have been passed over without notice, has occupied us so long that one or two other points must be taken very briefly.

**Other Effects.**—As to thermo-electric effects in the arc, it is probable, since the temperature differences are great, that they may affect some of the minor phenomena, but the known numerical insignificance of such effects in other directions leads us to suppose that they cannot play a

very important part in the relatively large energy changes taking place in the arc.

It is worthy of note that the arc behaves like a flexible conductor carrying a current, and can therefore be deflected by a magnet in accordance with laws to be presently explained. We have given an instance of this in Dr. Fleming's experiment (Fig. 223). The effect was noticed by Davy, who proposed to use it as an "electric blowpipe" in the manner depicted in Fig. 235. It has a practical application in the magnetic blow-outs used on tramway controllers as well as in the flame arcs referred to above.

The phenomena of alternate current arcs must be postponed until some of the simpler phenomena of alternate currents have been explained.

#### VIII.—ELECTRIC FURNACES.

Another application of the thermal effect of the electric current has risen to a position of great importance during the last few years. It depends upon the production of the heat in a confined space where the conditions for its escape by conduction and radiation are made as unfavourable as possible. The consequence is that the temperature rises to a high value, so much so that the most refractory metals and ores can be melted either in small or moderately large quantities. When we consider that according to the simple laws already explained the amount of heat produced per minute is very completely under control, and that this heat is produced exactly where it is wanted—that is, right in the middle of the mass to be acted upon, if necessary, and not outside it—it is not surprising that these methods of obtaining high temperatures are leading to important industrial results. The reduction of the price of aluminium from 20s. per lb., which was the average price between 1862 and 1888, to less than 1s. 6d. per lb., the present price, may be mentioned as one of these, and other instances could easily be adduced. Postponing the explanation of technological details, which properly belongs to the next section, the law already given for the production of heat by the current is

$$H = 0.24 C^2 R t$$

where  $H$  is the heat in *calories*,  $C$  the current in *amperes*,  $R$  the resistance in *ohms*, and  $t$  the time in *seconds*. To produce a great quantity of heat in a particular part of the circuit we must therefore insert at that point a resistance  $R$  with an abnormally high value. On a smaller scale the same principle is made use of in the construction of glow lamps, as already explained, but in actual electric furnaces we use not only the principle of the glow lamp but also that of the electric arc, which, as we have seen, liberates a great quantity of heat energy in a small space and at a very

high temperature. In addition, in many uses of electric furnaces the fused contents are such as to be acted on chemically by the passage of the current, and thus we have in full play a third method of absorbing the electrical energy inside the mass by means of the back E. M. F. due to electrolysis, the laws of which were explained at page 200.

Returning for a moment to the equation just given, it is obvious that as the current can be controlled by well-known methods in other parts of

the circuit, the quantity of heat produced per second in the furnace, and which depends on the *square* of the current, can be regulated with great nicety to any value which experience may have shown to be desirable. The maximum temperature attainable is, however, limited by the fact that no material is available with which to construct the furnace which will not itself sooner or later yield to the influence of these high temperatures.

#### Siemens' Early Furnace.—

The more modern and special furnaces will be described later, and we shall therefore, to illustrate the above principles, describe here only the earliest successful electric furnace invented by Sir William Siemens, and also a very convenient form of furnace for laboratory work subsequently constructed.

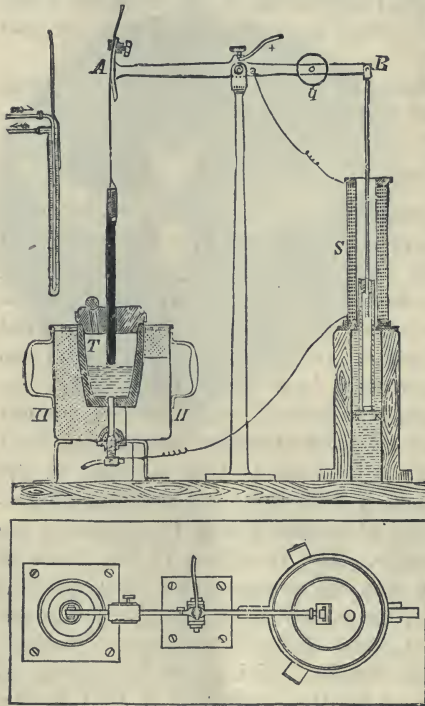

Fig. 236.—Siemens' Electric-Smelting Apparatus.

Siemens' early furnace, in which the electric arc was chiefly utilised, is illustrated in Fig. 236, in which T is a crucible consisting of graphite or other similar substance not easily fusible. This is surrounded by a kind of jacket (H) containing pieces of charcoal, or a similar substance that conducts heat badly and is not easily fused. There is a hole in the bottom of T, through which an iron, platinum, or carbon rod passes. There is also a hole in the lid of the crucible, through which the negative electrode passes. The negative pole of pressed carbon is suspended, by means of a copper strip at A, from the beam AB; to the end B is fastened a hollow cylinder of soft iron, which



moves freely inside the solenoid  $s$ . The attracting force of  $s$  may be balanced by means of a weight  $q$  on the beam. One end of the solenoid is connected with the positive, the other end with the negative, pole of the arc. The resistance of the arc may, therefore, be adjusted as required by sliding the weight  $q$  along the beam. If the resistance in the arc is increased by any cause, the current passing through the coil also increases, and the force of attraction overcomes the counterweight, causing the negative electrode to dip deeper into the crucible. If the resistance in the arc diminishes, the weight forces the cylinder back out of the spiral, lengthening the arc until equilibrium is restored. Besides the automatic regulation of the arc, it is of importance for success that the metal to be fused should form the positive pole, where the highest temperature is obtained. Sir William Siemens melted one pound of filings in an apparatus similar to the one here described in thirteen minutes; the crucible had a depth of 8 inches, and the power used was about 24 kilowatts.

When a carbon rod is used as the negative pole, the metal to be fused may sometimes undergo a chemical change; to avoid this the negative electrode must consist of a substance that causes no change. Siemens used a so-called water-pole (drawn in the figure separately)—*i.e.*, a tube of copper through which water is allowed to circulate. As regards the expense, Siemens found that by using a dynamo-electric machine, driven by a steam-engine, one pound of coal could melt nearly one pound of cast steel. The advantages of this process, some of which have been already referred to, are—(1) Theoretically the heat obtainable is unlimited; (2) the fusing takes place in a neutral atmosphere; (3) the process needs no lengthy preparations, and can be conducted under the eyes of the operator; (4) by using ordinary materials difficult to fuse, the temperature practically obtainable is very high, as in the electric crucible the fusing material has a higher temperature than the crucible itself; whilst in the ordinary method the temperature of the crucible surpasses that of the melting material.

**Ducretet's Furnace.**—These great advantages make the electric furnace a valuable addition to the resources of the chemist, either for research work or for many of the ordinary operations of the laboratory. A form of such a furnace, as modified by Messrs. Ducretet and Lejeune of Paris, is shown in Fig. 237. Ordinary electric light carbons  $c c'$  slide through the clamping cylinders  $p p'$ , and are brought together at right angles to one another just over the crucible  $c r$ . The crucible, according to the operation that has to be performed, consists of carbon, plumbago, lime, magnesia, etc. It is in a closed refractory chamber  $r$ , with an aperture  $Bo$  at the top through which the materials to be smelted can be introduced. When large currents are used, the carbon-holders  $p p'$  have to be kept cool by currents of water circulating through them. The front side

of the furnace chamber is closed by the removable screen *K*, which for many purposes can be made of deep ruby-red glass through which the operations in the crucible can be watched, but when the highest temperatures are developed it has to be made of a more refractory material, such as mica. There are apertures not shown in the figure, by which, if required, gases can be introduced into the furnace. The magnet *A* controls the play of the electric arc on the materials in the crucible, converting the arc, if need be, into a long flame, which acts as a veritable electric blow-pipe as explained on page 270. The maximum temperature attainable is about

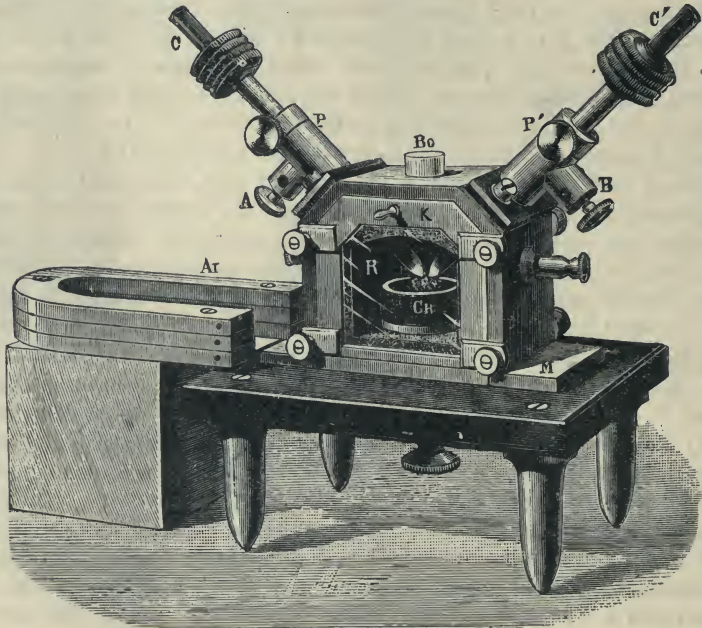

Fig. 237. —Ducretet's Electric Laboratory Furnace.

3,500° C., the temperature, according to M. Violle, at which carbon volatilises. With a current of about 12 amperes at 55 volts the most refractory ores can be reduced in a few minutes, and pure metals obtained in sufficient quantities for chemical analysis. In this way, at the *École Normale Supérieure*, specimens of metallic ruthenium and osmium were obtained.

The use of electric furnaces for many metallurgical purposes has been much developed during the last few years, and other electrical principles have been utilised, more especially in induction furnaces. The description of these developments will, however, be most conveniently postponed to the technical section.

## CHAPTER VII.

*THE MAGNETIC EFFECT OF THE CURRENT.*

## I.—ELEMENTARY LAWS.

WE have now to deal with the third effect by which we recognise a steady and continuous electric current—namely, the magnetic effect in the medium or media surrounding the conductor.

In treating this effect and following it in its various forms and their applications more than one method is available. In the earlier editions of this book Ampère's experiments on the mutual actions of neighbouring currents were taken as the starting point, and many of the phenomena were deduced from these experiments. Eventually, however, especially when the details of dynamos and motors had to be considered, it was necessary to introduce Faraday's conception of the magnetic field, without which, as now developed by his successors, the problems involved cannot be solved. Though Ampère's method is historically the older, it seems best to start at once with the Faraday field, for the Ampèrian attractions and repulsions referred to above are simple consequences of the interaction of the fields due to the two currents experimented with.

The simplest case to start with is that of the magnetic field\* near the centre of a long straight current.† In this case the magnetic lines of force\* are found to lie in planes perpendicular to the current, and in any of these planes when drawn according to the rules previously given (page 35) they are concentric circles (Fig. 238) whose common centre is the point where the plane cuts the axis or centre line of the conductor.

Faraday's method of investigation with iron filings, previously used for the magnetic fields due to permanent magnets, is available here; though great care is required to obtain good results, for in the absence of iron the fields are weak unless the currents used are very large. A vertical current should be passed through a hole in the centre of the card, as shown in Fig. 238. If fine iron filings are now sprinkled on the card, and the latter gently tapped, the filings will arrange themselves as shown in Fig. 239, which is copied from Faraday's researches. The appearance is that

\* For a full explanation of these terms see pages 27 and 34.

† In what follows, in order to avoid circumlocution, the word "current" will frequently be used instead of "conductor carrying a current."



of a whirl, and the circular shape of the lines of force is very strongly suggested. The dotted circles in Fig. 238 show these lines in perspective.

For the future, we have always to regard the magnetic field, represented by such lines, as surrounding every conductor in which a steady current

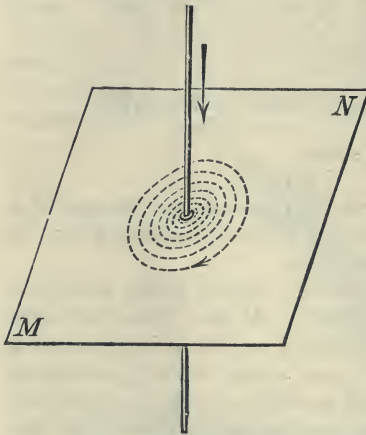

Fig. 238.—Lines of Force Round a Straight Current.

is flowing. If at any point two or more such fields co-exist the circles may be, as it were, pushed out of their places and even lose their circular shape, for the actual magnetic force at a point is the mechanical resultant of all the magnetic forces at that point. Similar deformations of the lines occur when two bar magnets are brought near together (see Figs. 23 and 24). The lines may also be distorted and deflected, and even their number changed if there be magnetic material in the field, just as the fields of the permanent magnets are distorted and modified by the presence of iron (see Figs. 25 to 27). But the lines accompany the current as they accompany the

permanent magnets, and their existence, or rather, that of the field which they represent, must never be overlooked.

It is important also to notice that the lines are *closed curves*, and that they can exist without the presence of any magnetic bodies or material. In this they differ from the lines due to permanent magnets, which always begin and end, as regards the surrounding medium, on magnets, either permanent or induced.

One further point remains—namely, the relation between the direction of the current and the direction of the lines. These two directions are indicated by arrows in Fig. 238, but some mnemonical rule is desirable to enable the reader to remember the relation. Many such rules have been devised, but perhaps the simplest is that known as the “corkscrew” rule—“If the direction of travel of a right-handed corkscrew represent the direction of the current in a straight conductor, the direction of rotation of the corkscrew will represent the direction of the magnetic lines of force.”

Thus, let  $s$  (Fig. 240) be an ordinary right-handed corkscrew and  $a$   $b$  be a fixed wire enclosed by its spirals. Now if the direction of the

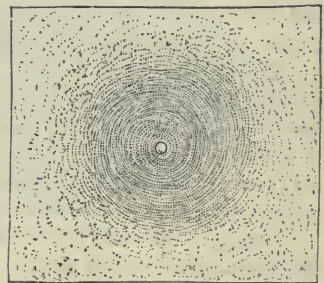

Fig. 239.—Magnetic Curves round a Straight Current.

current in the wire be from  $a$  to  $b$  the magnetic lines will encircle the wire in the direction of the curved arrow  $r o$ , which shows the direction

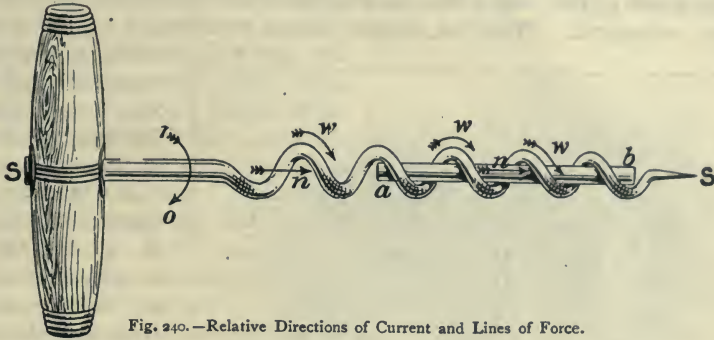

Fig. 240.—Relative Directions of Current and Lines of Force.

in which the corkscrew must be turned to advance from left to right along the wire  $a b$ .

Next consider what modification will take place if a long straight current, with lines of force of this kind in an infinite number of planes at right angles to it, be bent into a circular loop, such as is depicted in Fig. 241. The lines of force, both inside and outside the loop, will cross the plane of the loop at right angles, and all those which cross the loop on the inside will pass through the plane in one direction (downwards in the figure), whilst all on the outside will return through the plane in the opposite direction.

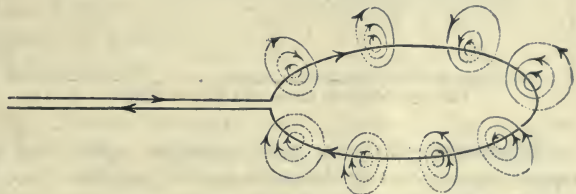

Fig. 241.—Lines of Force of a Circular Loop.

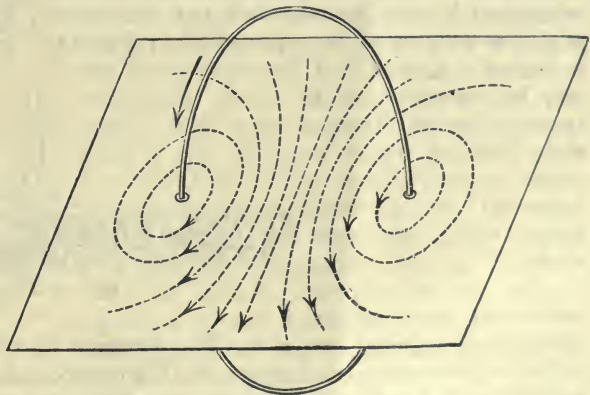

Fig. 242.—Lines of Force of a Circular Loop.

This will perhaps be better understood by an inspection of Fig. 242,

where two sets only of the magnetic curves are shown, one on each side of the current loop, each set being in the same plane at right angles to the plane of the loop. The lines of force are still circles, but are no longer concentric. With the electric circuit so arranged we can experi-

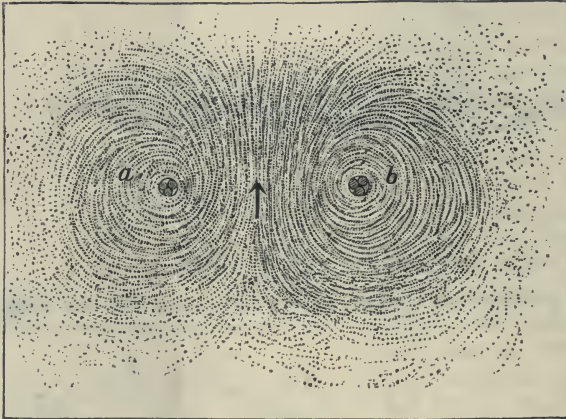

Fig. 243.—Magnetic Curves of a Circular Loop.

ment on the magnetic curves with our iron filings. The result is shown in Fig. 243, where the three wires shown in section at *a* and *b*, are carrying the current so that it ascends at *a* and descends at *b*. The arrow in the centre shows the direction of the magnetic curves there, where they form a fairly uniform field.

**Solenoids.**—Let us now superpose upon one another a number of equal circular current loops in such a way that they have a common axis, and therefore form a cylinder, and also so that the currents in each loop rotate round the common cylindrical axis in the same direction. In actual experimental work the loops are not true circles, but consecutive turns of a close-lying spiral as represented in Fig. 244. Such an arrangement is termed a *solenoid*. It may be considered as a system of parallel currents, each turn of which is almost a circle, and is connected by a small piece with the next circle.

The sum of all the connecting pieces will be equal to the straight line *A B*. The direction in which the current circulates in this system is indicated by the arrow-heads. The current in the straight wire *A B* flows in the opposite direction to that of the supposed connecting pieces between the circles. The effects of these two currents will neutralise each other, and only the circular currents need be taken into consideration. Down the inner space of the solenoid the lines of

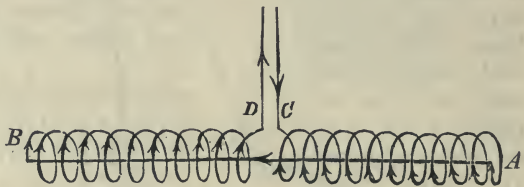

Fig. 244.—A Solenoid.



force of each turn will run in the same direction and the fields will reinforce one another.

This case can also be experimented upon with iron filings, the necessary card being cut so that it can be introduced a short distance into the solenoid along the axial line. Another of Faraday's figures (Fig. 245) illustrates the resulting magnetic curves. The wires carrying the current are shown in section at *a, a, a* on one side, and *b, b, b* on the other. If the current be assumed to be ascending in the wires *a* and descending in the wires *b* the central field will be in the direction indicated by the arrow.

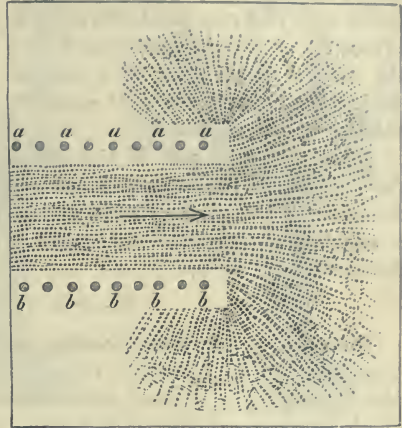

Fig. 245.—Magnetic Curves of a Solenoid.

It will be noticed that in Fig. 245 the magnetic curves stream out from the ends of the solenoid in a manner remarkably similar to that in which they stream out in Fig. 20 from the north-seeking pole of a bar magnet. Since in the outer space the lines of force have the same physical meaning in the two cases we should expect the same effects. In other words, the solenoid should behave like a bar magnet. The deduction can be tested by experiment in the manner shown in Fig. 246, where the wires leading the current in and out of the solenoid are brought up to two mercury cups *A* and *B* in such a way as to suspend the solenoid and leave it free to move in a horizontal plane.

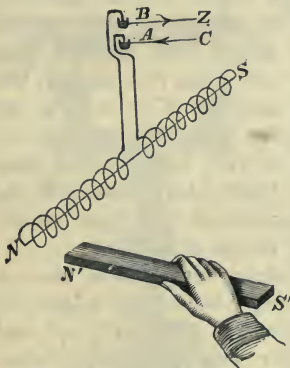

Fig. 246.—Solenoid Repelled by a Magnet.

The end from which the lines of force stream out has been marked *N* and that at which they return *s*, and by bringing the magnet *n' s'* near the suspended solenoid, it will be found to behave like a suspended magnet. The end *N* will be repelled by the north-seeking pole of the magnet and attracted by the south-seeking pole, whilst the end *s* behaves in exactly the opposite manner. Furthermore, if quite free to move, the solenoid, when carrying a current, will set in the earth's field like a compass needle with its end *N* pointing towards the magnetic north.

The connection between the direction of the lines of force in the

interior of a solenoid and the circulation of the current in the coils can also be brought under the "corkscrew" rule, only instead of the former case, in which we had a straight current with curved lines of force threaded on it, we now have a cylindrical swirl of current and straight lines of force inside it. The rule must therefore be modified as follows:—"If the direction of rotation of a right-handed corkscrew represent the direction of circulation of the current in the coils of a solenoid, the direction of travel of the screw (forwards or backwards) will represent the direction of the lines of force in the interior of the solenoid."

Thus, in Fig. 240, if the arrows  $w, w, w$  represent the direction of the current in the spirals of the corkscrew, the arrow  $n$  will represent the direction of the lines of force within those spirals, this being the direction in which the corkscrew will travel if turned right-handedly so as to follow the arrows  $w, w, w$ .

## II.—ELECTRO-MAGNETISM.

**Discovery of Electro-Magnetism.**—Arago, in 1820, developing Ampère's work, observed that iron filings which were near a copper wire conveying a current surrounded it cylindrically. The wire through which the current flowed did not attract the filings, but gave to them a distinct position; and when the filings were thus directed they attracted each other, and then covered the copper wire. The current in the copper wire converted each filing into a magnet; and caused these to place themselves with the longest axis at right angles to the direction of the current. The phenomenon disappeared whenever the current was interrupted. Arago found, further, that when iron needles were placed in a glass tube round which a current was made to circulate, the needles became magnetic; but the magnetism disappeared as soon as the current was stopped in the spiral. The magnetism was, however, retained after the ceasing of the current when, instead of iron, steel needles were taken. Almost simultaneously (in November, 1820) Davy observed the same effects, and also that if a wire carrying the current of a large battery were dipped in iron filings, the filings hung in chains around it.

The step from these experiments to the making of powerful electro-magnets is due to Sturgeon, who exhibited, in 1825, before the Society of Arts, in London, the two electro-magnets depicted in Figs. 247, 248, and 249. These figures\* are copied from the paper subsequently published in the *Transactions* of the Society. Fig. 247 is a side view and 248 a front view of an electro-magnet of horseshoe shape. The core consists of a bar of soft iron about a foot long and half an inch in diameter bent into the required shape, and, after being varnished to insulate it, overwound with a spiral of stout, bare copper wire. The ends of the wire dipped into the mercury cups  $c$  and  $z$ , the former of which was directly

\* The author is indebted to Dr. Silvanus P. Thompson for these figures.

connected to the copper pole of a large low resistance battery, and the latter could be connected to the zinc pole by the spanner *d*, which was used to connect the mercury cups *z* and *z'* and also to break the circuit at pleasure. The iron of the magnet weighed only *seven ounces*, but when the current was flowing in the spiral it was able to sustain a weight of *nine pounds* by the traction of the poles *N S*. This result far exceeded anything previously attained with permanent steel magnets. It should be noted that in the side view (Fig. 247) the poles are represented as being connected by the keeper or armature *y*. Also, if it be remembered that the current flows through the spiral from *c* to *z*, it will be found that the magnetic flux of lines in the iron follows the corkscrew rule given above. The reader should carefully verify this point.

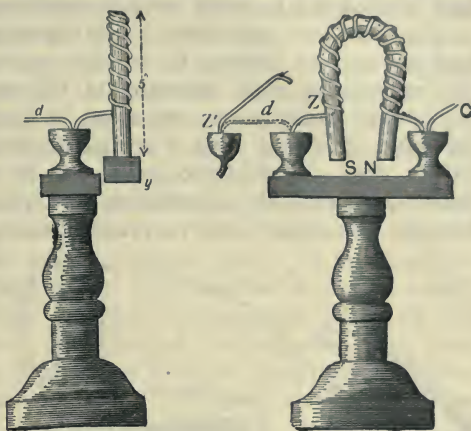

Fig. 247. Sturgeon's (1825) Electro-magnet. Fig. 248.

In Fig. 249 Sturgeon shows a straight solenoid into which rods to be magnetised are to be slipped. He observes that when a current flows in this spiral it "communicates magnetism to hardened steel bars as soon as they are put in, and renders soft iron within it magnetic during the time of action." He further remarks that the polarity of the magnetised material can be changed either by winding the spiral in the opposite direction, or, more simply, by reversing the connections to the battery so as to reverse the current. Either of these changes, of course, reverses the direction of the *circulation* of the current round the iron or steel.

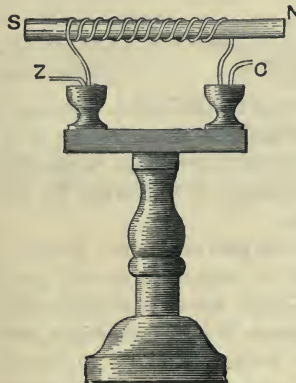

Fig. 249.—Sturgeon's Straight Electro-magnet.

**Magnetising Force of a Coil.**—The next step in advance was taken by Professor Joseph Henry of New York, who, in 1831, discovered

that a weak current circulating many times round an iron core produces as strong a magnetising effect as a much larger current circulating only a few times round the core. Put into modern language, this is the well-known *law of the ampere-turns*, which asserts that the magnetising force, or rather the *magneto-motive force of a coil*, is *proportional*



tional to the product of the current (amperes) by the number of turns in the coil, or, in other words, to the "ampere-turns." Henry's discovery is further interesting from the fact that its communication to Wheatstone a few years later enabled the latter to solve the problem of long-distance telegraphy.

The law just enunciated is so important that a numerical example may be used to impress it on the reader. Thus, suppose we have two magnetising coils externally of the same size and shape, but one wound with many turns, say 2,500, of fine insulated copper wire, whilst the other is wound with a comparatively few turns, say 125, of much thicker wire. Both these coils can be made to produce the same magnetic effect with a particular core placed inside, provided the current in the latter coil is proportionately greater than that in the

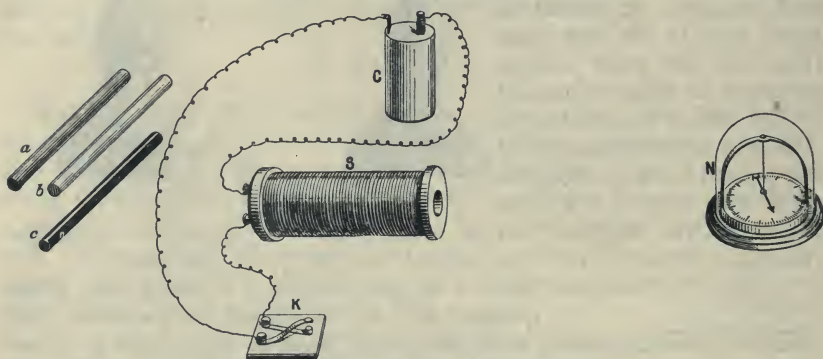

Fig. 250.—Experiment on the Magnetic Circuit.

former, so that the product of current by turns is the same for each. If, for instance, we send a current of  $\frac{1}{2}$  an ampere through the first coil, the ampere-turns will be  $\frac{1}{2} \times 2,500 = 1,250$ . To obtain a similar result with the second coil, we must send through it a current of 10 amperes, so that  $10 \times 125 = 1,250$  as before.

**The Magnetic Circuit.**—The law that we have just explained, namely, that *under similar circumstances* a certain number of ampere-turns will produce a definite effect, does not lead us very far, for in many practical cases the circumstances are not at all similar. For instance, if in the example just cited the core be changed from wrought iron to cast iron or to brass, we shall find, by quite simple tests, such as the deflection of a compass needle, that the field opposite the end of the solenoid varies considerably in strength, although the ampere-turns be kept unchanged. Put otherwise, this amounts to saying that the number of magnetic lines of force issuing from the solenoid core is different for each kind of core. The point can easily be examined experimentally with quite simple apparatus, such as is shown in Fig. 250. A solenoid *s*, a voltaic

cell  $c$ , and a key  $\kappa$  are arranged in circuit, the solenoid being placed at right angles to a suspended or pivoted compass needle  $N$ , and at a convenient distance from it. Cores  $a, b, c$ , etc., all of the same size and shape, but of different materials, can be introduced one at a time into the solenoid. The tangent of the angle of deflection of the compass needle when the key is pressed is a measure of the magnetic effect produced in each case, and the influence of the different cores can easily be shown. For more exact work a galvanometer and adjustable resistances should be introduced into the electric circuit to ensure the constancy of the current, but these and other precautions are unnecessary in a first examination of the effect, for the differences are readily detected. Now, in each case, we have the same number of ampere-turns, and therefore the same magneto-motive force. Why, then, the difference in the **magnetic flux**, as the total number of lines is called? It arises because we have been changing the medium in which the flux is set up, although we have not changed the magneto-motive force.

The case is very similar to that which we have been describing when discussing Ohm's law for electric circuits. In these the same electro-motive force gives rise to a great range of currents, according to the resistance of the electric circuit through which the current flows. In other words,

$$\text{electric current flow} = \frac{\text{electro-motive force}}{\text{resistance.}}$$

The denominator on the right hand side, as we have seen, depends entirely on the materials of which the circuit is composed and their geometrical shape and size.

So, in the magnetic case, the total number of lines set up by a given magnetising solenoid depends not only upon its magneto-motive force but also upon the material and geometrical shape and size of the magnetic circuit through which the lines pass. In short, we have

$$\text{magnetic flux} = \frac{\text{magneto-motive force}}{\text{reluctance.}}$$

The denominator of this fraction, the *reluctance*, is the term analogous to the resistance in the electric case, and when this equation was first used it was usually referred to as the *magnetic resistance*. But it was soon perceived that, apart from the danger of confusion, the analogy was not sufficiently close to justify the use of the same term in the two cases. Electric resistance causes heat to be generated, and therefore energy to be wasted in the electric circuit. In the magnetic circuit there is no similar waste of energy. Mr. Oliver Heaviside therefore suggested the use of the word reluctance for the magnetic case, and this suggestion has been very generally adopted.

Referring to the last equation, we see that with the same magneto-motive force (M. M. F.) the flux varies inversely as the reluctance. If we increase the reluctance we diminish the flux and *vice versâ*. The reluctance of wrought iron is less than that of cast iron, which, in its turn, is considerably less than that of brass. The substitution, therefore, of cast iron or brass for wrought iron, in the experiment of Fig. 250, produced the observed changes in the flux, although the change was only made in one part of the magnetic circuit. The reluctance ( $\lambda$ ) of any piece of material of uniform cross-section depends upon its specific reluctance ( $\frac{1}{\mu}$ ) and its length ( $l$ ) and sectional area ( $A$ ); the form of the equation being similar to that for electric resistance (see page 184). This equation is

$$\text{reluctance} = \text{specific reluctance} \times \frac{\text{length}}{\text{sectional area}},$$

or

$$\lambda = \frac{l}{\mu A};$$

in other words, the reluctance of the whole or of any part of a magnetic circuit is *directly proportional to its length and inversely proportional to its sectional area*.

The *specific reluctance* is a physical property of the material, and, like the specific resistance, its value must be obtained by experiment. It is usual, however, to express the results in terms of the *permeability* ( $\mu$ ), or specific magnetic conductivity, rather than in terms of its reciprocal ( $\frac{1}{\mu}$ ), the specific reluctance. This practice has grown up from another method of looking at the facts which we shall explain presently.

In applying the above equation to the calculation of the reluctance of any given magnetic circuit, we follow the same general rules that we use in the corresponding electric case. Unfortunately, the calculation is not as easy, for two reasons: firstly, the permeability of magnetic materials, especially iron, is not a constant quantity, but varies with the density of the magnetic lines in the iron; and secondly, there is *no known material which will insulate the magnetic lines* and compel them to flow in definite paths in the same way that dry air, guttapercha, and other insulating materials confine our electric currents in the conducting circuits. Thus not only the iron but also the *whole of the space surrounding our magnets* is permeable to magnetic lines, and its influence must be taken into account in the calculation.

In addition to the permeability of iron varying in the *same* specimen as the iron becomes more and more "saturated," different specimens differ widely in permeability. It is therefore necessary, before any calculations can be made, to determine, by direct experiment, the permeability and its variation under different conditions of the particular kind of iron which it is proposed to use.



## III.—PERMEABILITY.

If we fix our attention on any part of a magnetic field, such as the interior of the solenoid in Fig. 244, we know that the intensity of the field or the magnetic force at the point considered is represented numerically (assuming the space to be occupied with air or non-magnetic material) by the number of lines of force ( $H$ ) crossing a unit (or square centimetre) area held perpendicular to the direction of the lines. If we substitute magnetic for non-magnetic material the number of lines per square centimetre is altered and a greater number ( $B$ ) flows across the area. The increase is due to the greater *permeability* of the magnetic material, for more lines *go through* it than through the non-magnetic material. The ratio of the new number to the old is a measure of the permeability ( $\mu$ ), and we have

$$\mu = \frac{B}{H},$$

or

$$B = \mu H.$$

Thus  $\mu$  is a kind of multiplying factor by which the lines  $H$  are increased to the lines  $B$  by the action of the magnetic material. To determine  $\mu$  we have therefore to determine the values of  $B$  and  $H$  under exactly similar conditions.

**Measurement of Permeability.**—There are several good methods by which the permeability of a specimen of iron may be accurately determined. We select one which was employed by Dr. J. Hopkinson, and which is almost of classical interest.

The arrangement of the apparatus is shown diagrammatically in Fig. 251. The material to be tested is made into a ring of uniform cross-section, and this ring is closely overwound with a magnetising coil of insulated copper wire, represented by the thick-lined spiral in the figure. This coil is put in circuit through a reversing switch  $S$ , with a suitable battery  $B$  (usually a few secondary cells), an ampere-meter  $A$ , and an adjustable resistance  $R$ . At one part of the ring the magnetising coil is over-wound with many turns of fine insulated copper wire, and this "search-coil," as it is called, is joined in circuit with a ballistic galvanometer  $BG$ , a coil which can be moved on the limb of a permanent magnet  $M$ , but which is only used to bring the needle of  $BG$  to rest, and a coil  $RC$  used to standardise the galvanometer.

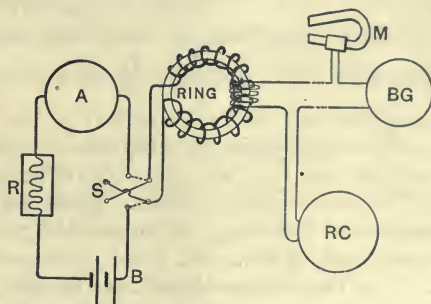

Fig. 251.—Measurement of Permeability

The experiment consists in suddenly changing the current in the magnetising coil, either by altering the resistance  $R$ , or by breaking or reversing the switch  $S$ , and observing the throw on the galvanometer  $BG$  caused by each change of current. Simultaneously the change in the magnetising current is noted by reading the ampere-meter  $A$ .

Now when a current is first passed into the magnetising coil a number of magnetic lines are suddenly produced in the iron ring. These lines all pass through the little search-coil, and as they come in give rise to a transient but cumulative induced E. M. F. in this coil in accordance with the laws of magneto-electric induction (*see page 416*). This induced E. M. F. depends upon the number of lines of force thus suddenly introduced, and gives rise to a corresponding transient current, the cumulative effect of which is measured by the first throw of the ballistic galvanometer. The observed throw of the galvanometer is thus proportional to the *change in the magnetic flux* in the ring, and the value of the change can be ascertained by using the coil  $RC$ , which allows a known number of lines to be introduced into or withdrawn from the galvanometer circuit.

The magneto-motive force can be calculated when we know the particulars of the windings in the magnetising coil and the current passed through it. For

$$\text{Magneto-motive force} = \frac{4\pi}{10} \times \text{ampere-turns,}$$

or

$$\text{M.M.F.} = 1.257 \times \text{ampere-turns,}$$

or rather more than  $1\frac{1}{4}$  times the ampere-turns. (It may be explained here that the multiplier  $\frac{4\pi}{10}$  is introduced to bring our magnetic units into line with our other units.)

When we know the magneto-motive force and the total flux, the ratio of the two will give the reluctance of the iron ring, which forms the whole magnetic current. Since we also know the length and cross-section of the ring, the permeability can be calculated from the equation already given. Or, if we prefer, we can find  $B$  by dividing the total flux by the cross-sectional area of the iron, so as to obtain the average flux per square centimetre. We can also find  $H$ , which in this case is equal to the magneto-motive force divided by the length of the magnetising coil, measured in centimetres. The ratio of  $B$  to  $H$  will give the same value of  $\mu$  as before.

#### IV.—MAGNETIC PROPERTIES OF IRON.

We are now in a position to discuss more fully the magnetic properties of materials, and especially of iron, in all its varied forms, these properties being investigated either by the method just described or one of the other methods alluded to.

The results are very numerous and complex; they may either be presented in the form of numerical tables giving the actual values measured in the various experiments or in the form of graphic curves constructed from these tables. We shall adopt the latter method because it presents to the eye in a form easily remembered information which could only be obtained by a close and laborious examination of numerical tables.

In Fig. 252, taken from Ewing's experiments, we exhibit curves showing the relations between **B** and **H** for different kinds of iron and steel. In these curves the values of the magnetising force **H** have been plotted horizontally from 0 to 50—that is, these numbers represent the number of lines of force per square centimetre that would have passed through the core of the magnetising solenoid had no iron or steel been present. The corresponding values of **B** have been plotted vertically from 0 to 16,000, showing in the most favourable case an enormous multiplying effect on the number of lines due to the presence of the soft annealed iron. All the curves start from the zero point—that is, the samples experimented upon had been carefully demagnetised before starting. The most striking curve is that for "soft annealed iron," which

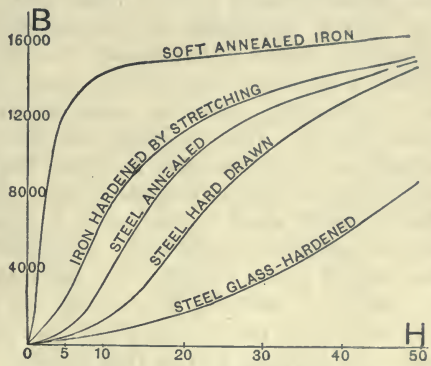

Fig. 252.—Curves of Magnetisation of Different Materials.

at a short distance from the zero point begins to rise very rapidly indeed, until for a value of  $H = 10$  the value of **B** is over 14,000, giving a value for the permeability  $\left(\frac{B}{H}\right)$  greater than 1,400. From about this point onward the rise is much less rapid, for an increase of **H** to 50, or to five times the previous amount, only increases **B** from about 14,000 to about 16,000. It is, therefore, much more difficult to get these last 2,000 lines than to obtain the first 14,000.

The curves for hardened iron wire ("hardened by stretching") and for annealed steel lie well below that for soft annealed iron, the difference at some points being considerable. In each of these curves three distinct stages can be traced in the process of magnetisation. There is first a more or less gradual rise, from the zero point, then a change to a much more rapid rise, and finally a bending of the curve once more towards the horizontal, indicating only a gradual rise in the magnetisation as larger and larger magnetising forces are employed.

Instead of drawing the curve which shows the relation between **B** and



**H**, we may represent the results in a form more convenient for some purposes by plotting, the connection between the permeability ( $\mu$ ) and the flux density **B** of the lines actually passing through the magnetic material. No further experimental data are required, as the values of  $\mu$   $\left( \text{or } \frac{\mathbf{B}}{\mathbf{H}} \right)$  can be calculated from the values used for the previous series of curves. Fig. 253, reproduced from Dr. S. P. Thompson's "Dynamo-Electric Machinery," exhibits such curves for five typical kinds of material. The differences in the permeability are very striking, and also the fact that in all cases the permeability rapidly falls as the flux density approaches the higher values. The curve for cast iron shows very graphically how inferior this material is in magnetic permeability to either wrought iron or mild steel. At a value of **B** = 8,000 lines per square centimetre its permeability has already sunk to 100, and diminishes to 50 at **B**=10,000; at the latter flux density the permeability of wrought iron is still over 1,700 for the commercial wrought iron, and nearly 2,000 for annealed wrought iron. It is interesting to note that the curves for these two materials cross one another at a flux density of 12,500, and that at higher flux densities the commercial variety is slightly better than the annealed iron. Still more interesting are the curves for mild steel, which is nearly pure iron with a very small percentage (about 0.2 per cent.) of carbon added. At moderate flux densities this material is not as good as the wrought iron, but as the density increases it rapidly comes to the front, until for **B** = 19,000 the unannealed specimen has a value of  $\mu = 350$ , and the annealed one  $\mu = 560$  as against  $\mu = 130$ , the highest value for wrought iron at this density. These and other properties have caused mild steel to supplant wrought iron very largely of late years for certain magnetic parts of heavy electrical machinery.

*Unmagnetisable Steels.*—One of the most curious facts connected with the magnetic properties of iron is the effect produced on these properties by the presence of foreign substances. Attention has already been drawn to the differences in permeability of steel and wrought iron, and, as is well known, strong permanent magnets can be made of steel, whilst wrought iron is practically useless for the purpose. Yet steel only differs chemically from wrought iron by the presence of a small quantity of carbon, the percentage amount of which is very much smaller than the percentage change produced in any magnetic property, *e.g.* the permeability, by its presence. Moreover, carbon is not a magnetic body in any one of its three well-known forms, and yet the presence of a small percentage of it in the iron enables the latter to powerfully retain the induced magnetisation after the inducing magnetic field has been removed.

The effect of alloying good magnetic steel with a small quantity of manganese is still more curious, for, with the latter present in certain proportions, the steel becomes almost non-magnetic. Thus, a specimen

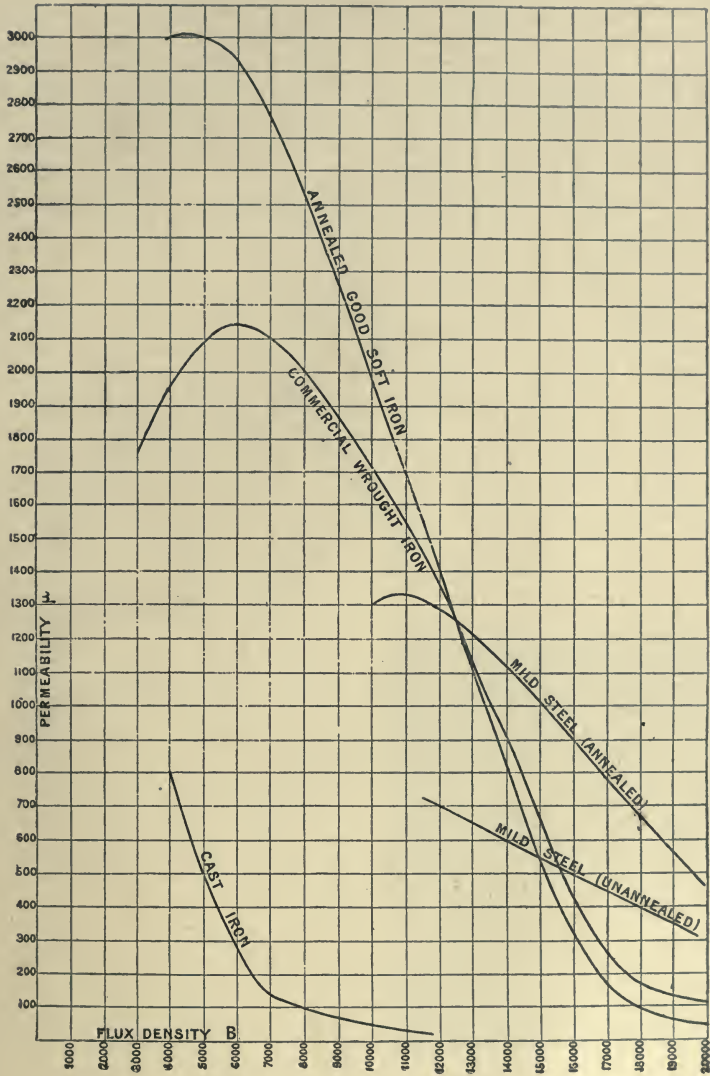

Fig. 253.—Permeability Curves for Iron.

of steel containing 15 per cent. of manganese was found to be almost unmagnetisable, the magnetic moment (*see* page 28) of a specimen subjected to a strong magnetising force being less than  $\frac{1}{7000}$ th of that of a similar piece of good magnetic steel. Another specimen of manganese steel, containing 12 per cent. of manganese and 1 per cent. of carbon, had a permeability varying between 1.3 and 1.5 in either weak or strong fields. Compare this with the permeabilities shown in Fig. 253.

But perhaps the most curious fact of all is that an alloy of two metals, steel and nickel, both magnetic, produces a substance which is nearly non-magnetic. A nickel-steel containing 25 per cent. of nickel has been observed to have a permeability  $\mu = 1.4$ , whether the field in which it is placed be strong or weak. This value for  $\mu$  is very much below the corresponding value for either of the materials of which the alloy is made. As these manganese and nickel steels have valuable mechanical properties, the fact that they are non-magnetic may prove advantageous in the construction of certain apparatus and machines. The phenomena, however, are very complex, and the greatest care must be exercised in applying any results. For instance, in the case of the steel just referred to, Hopkinson found that it became magnetic when cooled below  $0^{\circ}$  C. More curious still, on being heated up from the low temperature, it retained its magnetic properties until the temperature was raised to  $580^{\circ}$  C., when it again became non-magnetic, and remained so when cooled to ordinary temperatures.

**Hysteresis.**—We shall now refer to a magnetic property of iron which

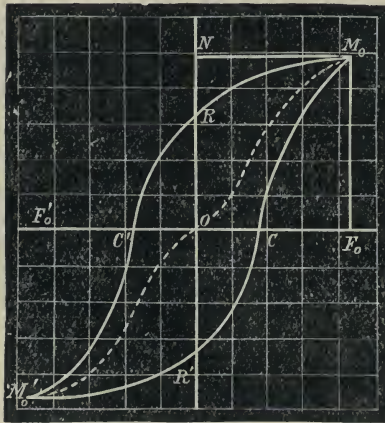

Fig. 254.—Typical Hysteresis Loop.

has most important consequences when this material is used in the construction of many kinds of electrical machinery and apparatus. In the experiments whose results are exhibited in the curves of Fig. 252, the material was; first of all, carefully demagnetised, and the curves show the effect produced by gradually increasing the magnetising force  $H$  from 0 to 50.

The experiments, however, may be carried further by observing the effect produced by a gradual diminution of  $H$  after it has been pushed up to the highest value either attainable or contemplated. The general result is shown in Fig. 254, where

the point  $M_0$  indicates the magnetic induction  $ON$  produced by  $OF_0$ , the highest value of the magnetising force used. When this force  $OF_0$ ,



is gradually diminished to zero the magnetic induction only falls along the curve  $M_oR$  to the value  $OR$ , which is a considerable fraction of the highest value  $ON$ . Let the magnetising force be now reversed and gradually increased; it will be found that the induction for the different values of this reversed force is given by the curve  $RC'M'_o$ , for which the magnetic force, being negative, is plotted to the left instead of to the right of  $O$ . Similarly negative magnetic inductions are plotted below the line  $C'Oc$ , because the positive values are plotted above that line. Thus,  $M'_o$  represents the highest negative induction produced by the highest negative value of  $H$  used.

But if after reaching  $M'_o$  the magnetising force be diminished, the curve obtained is not  $M'_oC'R$  but  $M'_oR'$ , the ordinate  $OR'$  being the negative value of  $B$  when  $H$  is again  $= 0$ ; and when  $H$  is again reversed so as to become positive once more, and is then gradually increased to the value  $OF_o$ , the corresponding values of  $B$  are given by the curve  $R'CM_o$ , the end of which is at the point  $M_o$ , reached during the first magnetisation. If, now, the magnetising force be caused to oscillate continuously between the maximum positive value  $OF_o$  and the maximum negative value  $OF'_o$ , being reversed each time it passes through the value  $0$ , the corresponding values of  $B$  will, over and over again, trace out the cyclic curve  $M_oRC'M'_oR'CM_o$ , being always found on the branch  $M_oRC'M'_o$  as the force falls from  $F_o$  to  $F'_o$ , and on the branch  $M'_oR'CM_o$  as the force rises from  $F'_o$  to  $F_o$ .

To interpret the meaning of this curious behaviour, draw the dotted curve  $M_oOM'_o$  half-way between the falling and rising curves, and therefore representing the mean value of  $B$  for each value of  $H$ , irrespective of the direction in which  $H$  is moving, *i.e.* whether increasing\* or decreasing. On comparing the actual curves  $M_oRC'M'_o$  and  $M'_oR'CM_o$  with  $M_oOM'_o$ , we see that when  $H$  is decreasing the value of  $B$  is always larger than the mean value—in other words,  $B$  does not decrease rapidly enough; and when  $H$  is increasing  $B$  is always smaller than the mean—that is,  $B$  does not increase rapidly enough. Thus the value of  $B$  is *always too large when  $H$  is diminishing, and too small when  $H$  is increasing*. In other words, the value of  $B$  *lags* behind the mean value for all changes in  $H$ . To this phenomenon Professor Ewing, who discovered it, gave the name of **hysteresis** (Greek *ὑστερεω*, to lag behind).

It is worthy of special note that the portion  $OM_o$  of the mean curve has the general shape, near the origin, of the ordinary magnetisation curve (Fig. 252) though, at first sight, the hysteresis loop  $[M_oC'M'_oC'M_o]$  appears to contain no trace of this peculiarity of the previous curve.

\* The terms *increasing* and *decreasing* are here used in their strict algebraic sense, it being understood that a negative increase is, in reality, a decrease, and *vice versa*, and consequently that a large negative value of a quantity is *less* than a small negative value, and that all negative values are less than zero.

An ingenious apparatus, invented by Ewing, for graphically projecting hysteresis curves on a screen, is shown in Fig. 255. A light mirror

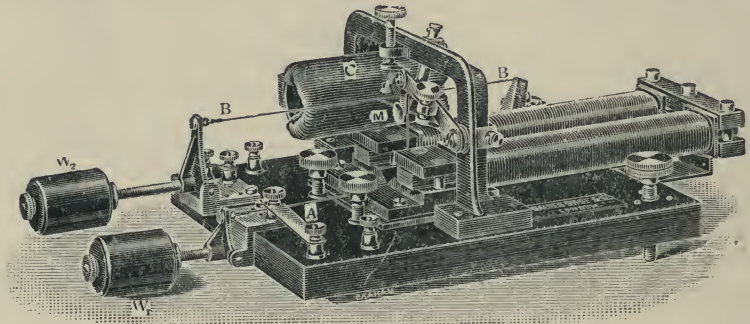

Fig. 255.—Ewing's Hysteresis Curve Tracer.

*M* is caused to oscillate, in step with the magnetising force, round a vertical axis, so that a ray of light reflected from it will move horizontally. Simultaneously the same mirror is made to oscillate, in step with the corresponding values of *B*, round a horizontal axis, so that the ray of light is, by this movement, deflected vertically. As both

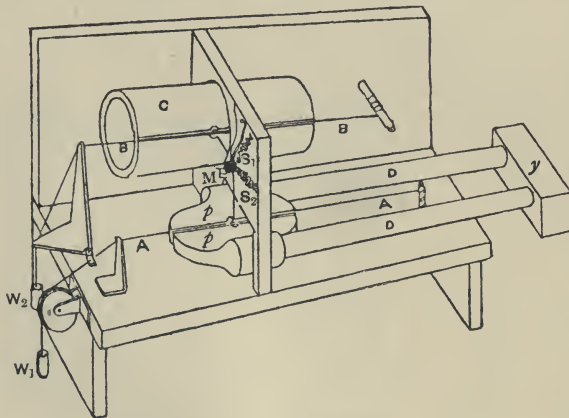

Fig. 256.—Diagram of Curve Tracer.

movements are given to the mirror simultaneously the motions are compounded and the reflected ray traces out the hysteresis curve.

Fig. 256 shows diagrammatically how the apparatus is arranged. The mirror *M* is pivoted on a single needle point so as to be free to move in any direction, and its movement is controlled by vertical and

horizontal threads attached respectively to the stretched wires *AA* and *BB*. The threads are kept taut by the light springs *s<sub>1</sub>* and *s<sub>2</sub>*, by which their tension can be adjusted. The wire *AA*, which is kept stretched by the weight *w<sub>1</sub>*, is traversed by a current of about 4 amperes, which is kept constant during any series of experiments. It passes through a long gap between the pole pieces *pp* of an electro-magnet, of which the rods

$DD$  are the cores and  $y$  is the yoke. The cores  $DD$  are the specimens of iron which are being examined for hysteresis; they are surrounded by magnetising coils (not shown in the diagram, but clearly seen in Fig. 255), through which the necessary magnetising currents can be passed.

The arrangements for changing these cores and connecting them to the yoke and the pole pieces can be seen in Fig. 255. The magnitude of the magnetic field produced in the gap between  $p$  and  $p'$  by any magnetising currents will depend on the magnetic properties of the cores  $DD$ , and the current-carrying wire  $AA$  will be moved vertically either upwards or downwards, according to the direction of the field, and with a force proportional to the strength of the field. This movement, therefore, depends upon and is controlled by the values of  $B$  in the cores  $DD$ ; it gives rise to a vertical movement in the spot of light reflected from the mirror.

The other wire  $BB$ , kept stretched by  $w_2$ , passes through the polar gap of the circular magnet  $c$ , the core only of which is shown in the diagram. By a reference to Fig. 255 it will be seen that this core is overwound longitudinally by a magnetising coil, and the magnetic circuit being nearly closed, a strong and constant field can be produced in the gap through which the wire  $BB$  passes. The exciting coil for this circular magnet is put in circuit with the wire  $AA$ , and is traversed by the same constant current which flows through the wire. On the other hand, the wire  $BB$  is in circuit with the exciting coils of the magnet  $DD$ , and is traversed by the varying current passing through those coils. It is therefore moved horizontally inwards or outwards, according to the direction of the current passing along it, and to an extent depending on the magnitude of that current. It thus controls the horizontal movement of the mirror  $M$ , which therefore depends on the magnetising force  $H$  of the coils of the magnet  $DD$  being proportional to the current in  $BB$ .

The electrical connection of the coils of  $DD$  and the wire  $BB$  ensures that the horizontal and vertical movements of the mirror shall be in step with one another, and therefore when a current varying continuously from  $\frac{1}{T}C$  to  $-C$  and back again is passed through this circuit, the reflected light traces out the hysteresis curve. An ingenious liquid rheostat and reverser for altering this current in the continuous manner required is usually supplied with the apparatus as made by Nalder Bros. and Co.

By the aid of such apparatus it is easy to show that the actual size of the hysteresis loop in any specimen of iron depends upon the range or amplitude of the fluctuations of the magnetising force  $H$ . Thus, if  $H$  oscillates between the values  $ox_1$  and  $ox'_1$  (Fig. 257) we get the loop  $a_1r_1a'_1r'_1a_1$ , but if we increase the amplitude of  $H$  so that its value oscillates between  $ox_2$  and  $ox'_2$  we obtain the larger loop  $a_2r_2a'_2r'_2a_2$ . And if we take still larger limits for  $H$ —namely,  $ox_3$  and  $ox'_3$ —we get the still larger loop  $a_3r_3a'_3r'_3a_3$ .



Moreover, it can be easily shown that hysteresis makes itself felt in all changes of the magnetising force, and that hysteresis loops are

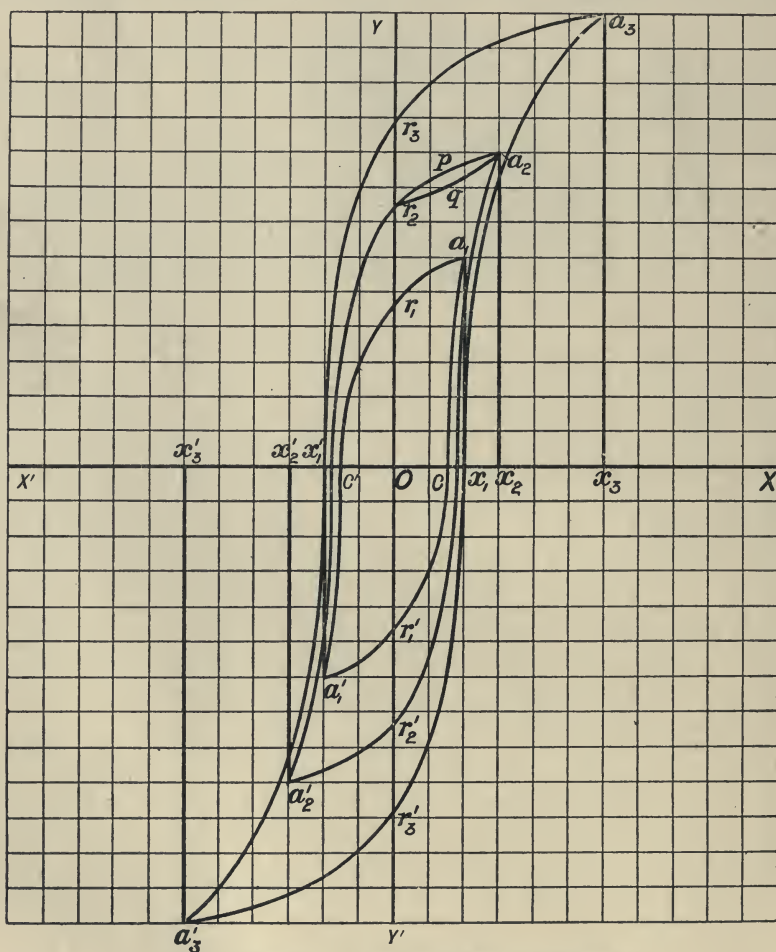

Fig. 257.—Hysteresis Loops for Different Magnetising Forces.

obtained whenever  $H$  passes through a complete cycle of values, especially if these are repeated over and over again. Thus, if  $H$  is diminished from the value  $ox_2$  to zero, and then, instead of being reversed, is again brought back to the value  $ox_2$ , the values of  $B$  will be given by the curve  $a_2pr_2qa_2$ , in which the upper half  $a_2pr_2$  is obtained when  $H$  is decreasing in value and the lower half  $r_2qa_2$  when  $H$  is increasing.

*Energy lost through hysteresis.*—The subject of hysteresis acquires great practical importance from the fact that the existence of this magnetic lagging leads to a degradation and loss of energy whenever a piece of material is subjected to cycles of magnetisation; this energy, whatever the details of the molecular process may be, eventually appears as heat in the material. It can be shown mathematically that whenever the material is carried round a complete cycle of magnetisation energy is dissipated, and that the amount of energy so dissipated per unit volume is measured by the area of the hysteresis loop. If we use the C. G. S. system of units, and the scales for **B** and **H** are in the absolute units of the system, then the area of the loop is the number of *ergs* of energy lost *per cycle per cubic centimetre* of material. The fact that energy is used up when iron is passed through successive magnetic cycles is the principle upon which Professor Ewing bases his "Hysteresis Meter," which will be described in the later section, and by which the hysteresis loss in different specimens of sheet iron can be rapidly compared. In modern electrical engineering large masses of iron are subjected to these cyclic changes, as, for instance, in the armatures of dynamos and the cores of transformers or induction coils. As the number of cycles (30 to 100 or more) per second is high, and the number of cubic centimetres of material large, the amount of energy dissipated per second as measured in watts ( $10^7$  ergs. per second) becomes sometimes serious.

But it is important to note that whatever the mass of the material and the frequency (or number of cycles per second), the loss by hysteresis is directly proportional to the area of the hysteresis loop for the particular cycle used. Hence the necessity, in the above and similar cases, of selecting material whose loops have the smallest attainable area. The practical significance of the difference between the loops **AA'** and **BB'** in Fig. 259, to which we shall refer later, becomes evident.

The chief, though not the only, factor which determines the area of the hysteresis loop is its width where it crosses the line **xox'** (Fig. 257); and this, we shall presently see, measures the value of the coercive force of the material. It may therefore be interesting to notice the values, collected in the following table, of the *coercive force* in different materials:—

Wrought iron (annealed) ... ..	1·8
"    " (hardened) ... ..	4·2
Mild cast steel (annealed) ... ..	9·0
"    "    " (hardened) ... ..	29·0
Grey cast iron ... ..	15·0
Steel (annealed) ... ..	22·0
" (glass hard) ... ..	40·0
Nickel (soft) ... ..	7·5
" (hardened) ... ..	18·0
Cobalt (1 per cent. iron) annealed ... ..	7·5

But further, on reference to Fig. 257, it will be noticed that the area of the loop also depends on the maximum value of the magnetic flux **B**. An empirical law, known as *Steinmetz's law*, from the name of its discoverer, connects the loop area or the energy *w* wasted per unit volume per cycle with the value of the maximum flux. This connection is given by the equation

$$w = c B^{1.6},$$

where *c* is a multiplier depending on the material and known as the *co-efficient of hysteresis*. If the C. G. S. system be used, that is, if *w* be the ergs wasted per cycle per cubic centimetre of material, the following are some values of *c* in different cases:—

Annealed wrought iron	...	...	...	0.00202
Annealed mild steel	...	...	...	0.00262
Annealed steel	...	...	...	0.00600
Tempered steel	...	...	...	0.00954
Grey cast iron	...	...	...	0.0183
Manganese steel	...	...	...	0.0596
Tungsten steel	...	...	...	0.0578

The actual values of the energy wasted by hysteresis in typical cases will be referred to again later.

Any change in the conditions or circumstances of the material tested

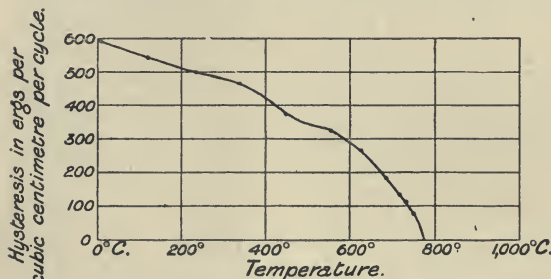

Fig. 258.—Effects of Temperature on Loss of Energy by Hysteresis.

usually affects the hysteresis loop. We shall presently see (Fig. 259) that *hardening* increases the hysteresis area and diminishes the permeability. This is true by whatever method the hardening is effected.

If the material be loaded in any way so as to be put in a state of mechanical strain the usual effect is to diminish the permeability and increase the hysteresis area.

The effects of *vibration* are in the opposite direction—namely, to diminish the hysteresis; it would appear as if the shaking of the molecules enabled them more readily to respond to the requirements of the changing magnetising forces. The effects of a rise of *temperature* are also to diminish the hysteresis loss, as might be expected from the results for vibrations. This effect is shown graphically in the curve in Fig. 258, which gives the numerical results of Dr. Morris's experiments on the energy lost through hysteresis by the specimen which is again referred to in Figs. 266 and 267. It will be noticed that the loss per cycle per cubic centimetre diminishes continuously, though somewhat irregularly, from 0° to 780° C., and vanishes at the latter, *i.e.* the critical, temperature.



The hysteresis effects so far considered depend only on the changes in the magnetising field and are not dependent on time. There is, however, a lag which requires time to develop, and is therefore not so perceptible in rapid cycles as under steady forces. Starting with demagnetised material, let  $H$  be suddenly put on, the value chosen being not too high.  $B$  at once takes up a definite corresponding value as given on the curves already discussed. But if  $H$  be kept on steadily at the above value it will be found that  $B$  gradually creeps up as time goes on until, in certain cases and for low magnetisations, the percentage increase becomes large. Thus, in some experiments of Ewing's, the permeability, as measured by the instantaneous effect, was 127, but, the magnetising force being kept on steadily, this had grown to 210 sixty seconds later. The material gradually yields to the magnetic stress, much as a viscous body would to a steadily applied force, and therefore the name of *viscous hysteresis* has been used to denote this time-lag.

**Residual Magnetisation, Retentivity and Saturation.**—The magnetisation curves (Fig. 252) and the hysteresis curves give numerical expression to some of the magnetic properties of iron and steel, first observed by Gilbert, and referred to in the introductory chapters (pp. 2 to 4). Taking any set of hysteresis loops, such as those shown in Fig. 257, the points  $r_1, r_2, r_3$ , etc., where the curves cross the axes  $y y'$  on the descending side, indicate the values,  $or_1, or_2, or_3$ , of  $B$  when  $H = 0$ . These ordinates, therefore, are proportional to the *residual magnetisation* which *remains* in the specimen under test when the corresponding maximum magnetising forces are suppressed, and may be more briefly referred to as the *remanence* of the material under each of the several conditions.

Then again, the negative abscissa  $oc'$  represents the negative magnetising force that must be applied to shake out or remove this residual magnetisation. It may be regarded as being needed to neutralise the positive *retentivity* or *coercive force* with which the material itself, whatever may be the cause, holds in a part of the magnetisation impressed upon it by the external magnetising force. In fact,  $oc'$  is a measure, in definite magnetic units, of the property of the material vaguely referred to as *coercive* or *coercitive* force from an early period in the development of the science of magnetism.

Another long-established property of magnetic material, namely, *saturation*, is graphically depicted in the magnetisation curves of Fig. 252. The very gradual slope of the upper part of the wrought iron curve shows this best. It is evident that, as the magnetising force approaches the higher values, the material responds with less and less readiness to the successive increases. In short, it is approaching a state in which it is conceivable that large increases in  $H$  would have no effect on  $B$ . In such a state the material may be said to be *saturated*, and this

term also was employed early in the science. As indicating what is meant we may note some of the higher values of  $B$  which have been observed by various experimenters. For charcoal sheet iron, Bosanquet has obtained the value  $B = 29,388$ , whilst Ewing with a specimen of Low Moor (wrought) iron first obtained the value  $B = 31,560$ , and afterwards, by using very special appliances, which enabled him to push the value of  $H$  up to 24,500, he obtained with this enormous magnetising force a value of  $B = 45,350$ . It will be noticed that with the material so

highly saturated, the value of the permeability ( $\mu$ ) has fallen to 1.85

( $= \frac{45,350}{24,500}$ ). For cobalt the

highest value of  $B$  on record is about 23,300, whilst for nickel wire it is only about 19,200.

The values of the retentivity and the coercive force referred to in the last paragraph vary widely in different samples of iron and steel. These differences are shown graphically in Fig. 259, which gives the hysteresis loops, all drawn to the same scale, for four different materials. The loop  $AA'$  was obtained from a specimen of annealed cast steel, a material which is now largely used in the construction of large electro-magnets, especially for dynamo machines. The loop is narrow, with a low value of the coercive force. The next loop  $BB'$  for another specimen of the same material shows the effects

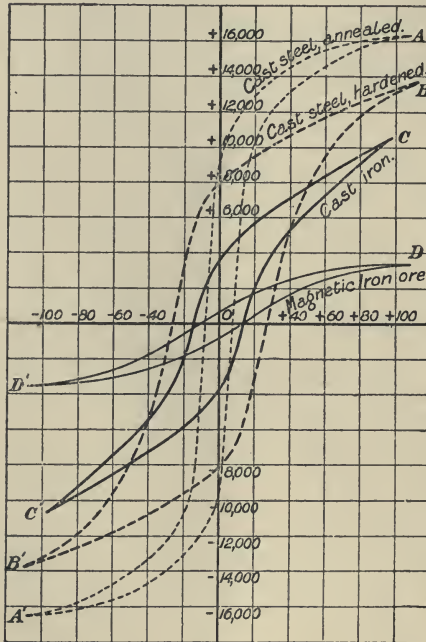

Fig. 259.—Hysteresis Loops for Various Kinds of Iron.

of hardening. The maximum value of  $B$  is reduced and the loop considerably widened, the value of the coercive force being nearly trebled. In the next loop  $CC'$ , for cast iron, the saturation value is again lower, but the loop is not so wide as the preceding. The last loop  $DD'$  is interesting from the fact that it is for lodestone or magnetic iron ore, which is an oxide of iron ( $Fe_3O_4$ ), and not the metal itself. The highest value of  $B$  shown is about 3,500, as against over 16,000, for the loop  $AA'$ , and the coercive force has about the same value as in the cast iron loop  $CC'$ . In view of the part the lodestone played in the early history of the science, the numerical comparison is curious and suggestive.

The general numerical relations of the quantities for the highest magnetising forces used are shown in the following table, which has been drawn up from the curves.

Material.	Maximum Magnetising Force.	Permeability. $\mu$	Magnetic Induction. $B$	Remanence.	Percentage Remanence.	Retentivity.
Cast steel, annealed ...	108	150	16,200	9,500	58.6	9
Cast steel, hardened ...	112	121	13,600	8,100	59.5	29
Cast iron ...	96	106	10,150	3,500	34.5	15
Magnetic iron ore ...	110	32	3,500	600	17.1	11

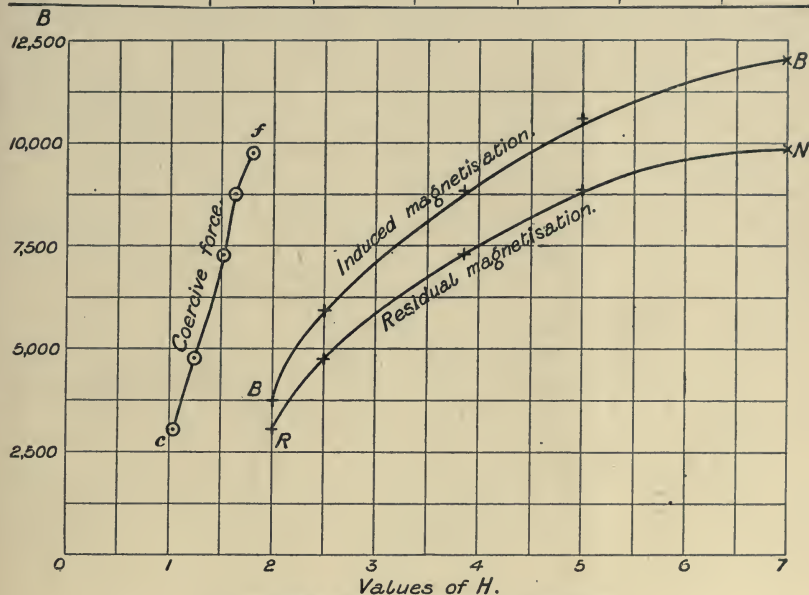

Fig. 260.—Residual Magnetisation and Coercive Force.

It will be observed that the annealed cast steel, though retaining as much as 58.6 per cent. of its magnetisation under induction, only retains it with a retentivity or coercive force of 9, whilst the hardened cast steel holds its 59.5 per cent. of residual magnetisation with a coercive force of 29, or more than three times as great. In regard to the magnetic iron ore, not only is the permeability low, but so also are the percentage magnetisation retained and the retentivity.

The relation between the residual and the total magnetisation induced with different magnetising forces is shown in Fig. 260, which has been drawn from some experiments on a very good magnetic sample of wrought iron. The upper curve *BB* gives the total magnetisation



(B) for the different values of  $H$ , and the lower curve  $RN$  shows the residual magnetisation or remanence. In this specimen the permeability rises to 2,400, and over 80 per cent. of the magnetisation remains. The retentivity, 1·8, is, however, very low, as might be expected from the small magnetising forces required. The values of the retentivity corresponding to the different remanences are shown in the short curve (*cf*) on the left.

V.—MAGNETIC PROPERTIES OF VARIOUS MATERIALS.

Although iron in many of its various forms is, *par excellence*, the magnetic material, it is not the only material which has an appreciable permeability

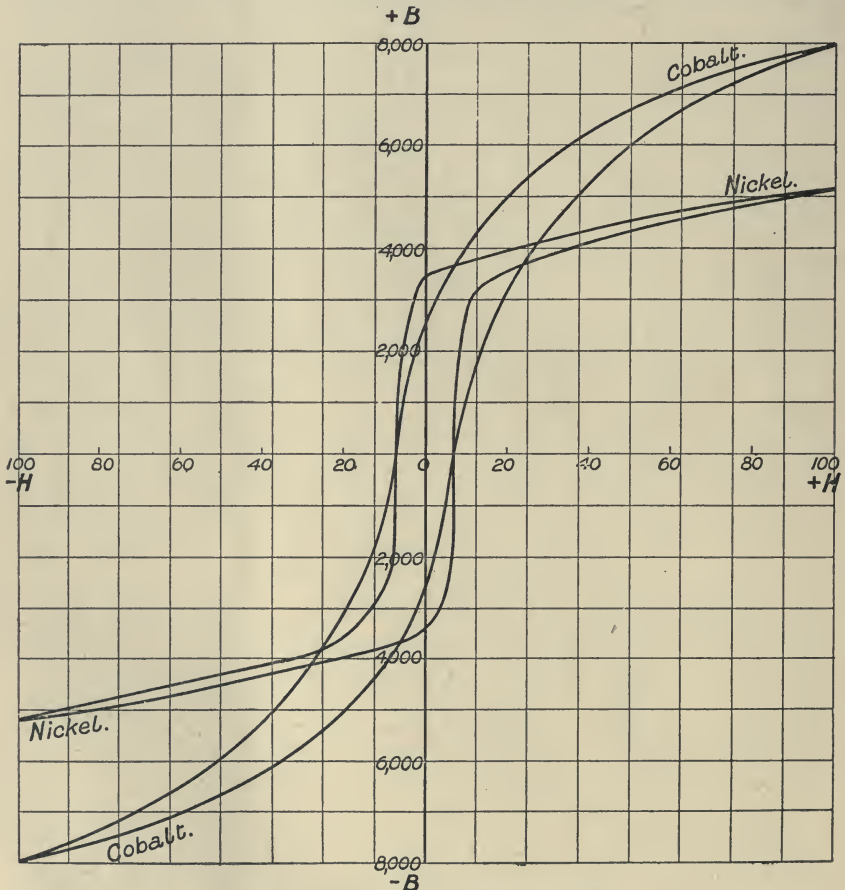

Fig. 261.—Hysteresis Loops of Cobalt and Nickel.

when placed in a magnetic field. Nickel and cobalt, two metals related closely to each other and less closely to iron, exhibit distinct magnetic properties, the latter having as high a permeability as many samples of cast iron. They also exhibit various kinds of hysteresis, and their magnetic properties are affected by changes of temperature.

In Fig. 261 we give hysteresis loops for these two metals, the one for cobalt being plotted from results obtained by Dr. Fleming, and that for nickel from experiments by Professor Ewing. The sample of cobalt used by Dr. Fleming and his co-experimenters was not quite pure, for it contained about 1 per cent. of iron, and it is impossible to say what effect this impurity had on the curve. In both cases the metal was carefully annealed.

Du Bois has experimented upon the behaviour of soft wrought iron, nickel, and cobalt in very strong magnetising fields, and from his experiments the curves of Fig. 262 have been plotted. These curves show very graphically the relative magnetic position of good magnetic specimens of the three metals. The specimen of nickel

contained 99 per cent. of the metal, but the specimen of cobalt was not so pure, as it contained nearly 6 per cent. of nickel and nearly 1 per cent. of iron.

**Diamagnetism.** — *Paramagnetic and Diamagnetic Bodies.* — By using very powerful electro-magnets the investigation can be pushed much further, and on careful examination it is found that a great

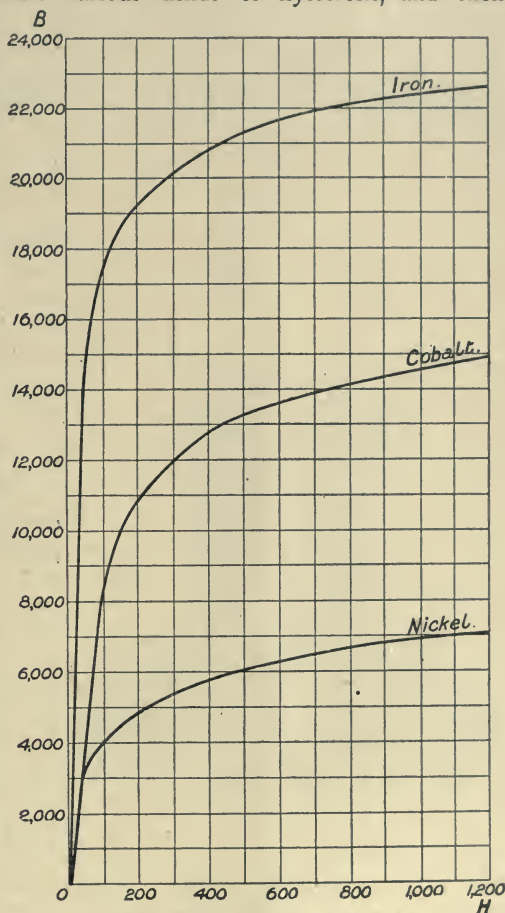

Fig. 262. — Magnetisation in Strong Fields.

number of bodies are affected by a strong magnetic field, although the effects produced are very feeble indeed when compared with those exhibited by iron, nickel and cobalt. Moreover, the effects differ in kind as well as in degree. Some substances behave similarly to iron; that is, they act so as to increase the number of lines passing through the space they occupy as compared with the number passing through empty space. Such substances are called *paramagnetic*; their permeability is greater than unity. Others act oppositely and diminish the number of lines passing through the space; they are called *diamagnetic*, and have a permeability less than unity.

The substances called paramagnetic are attracted by both poles of a magnet, and those called diamagnetic are repelled by both poles. Faraday, in 1845, pointed out that almost all bodies can be placed under one or other of these heads. To determine to which group most substances belong very powerful magnets have to be used. Fig. 263 shows an apparatus for diamagnetic determinations. On the iron yoke-piece P are fastened the two coils and cores N and S. Pieces of soft iron are screwed to the ends, and into these pole-pieces are inserted the pointed iron cylinders  $e, e_1$ , which can be adjusted by means of the screws  $s, s_1$ . Objects to be examined may be either placed upon R, the top of which is movable, or suspended from T. An iron bar brought

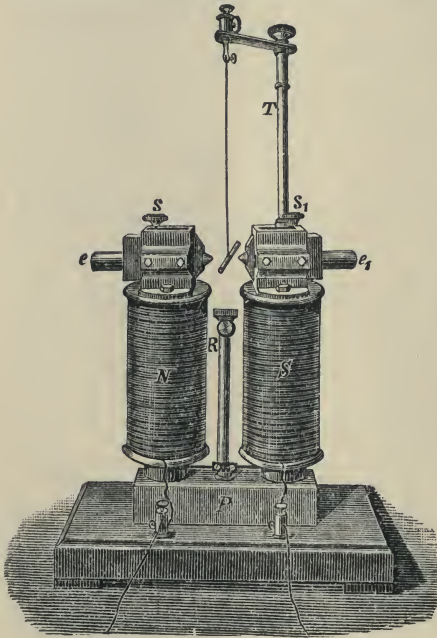

Fig. 263.—Apparatus for Diamagnetic Experiments.

between the poles of this instrument will set itself in the line of the poles; or, as Faraday called it, axially. If bismuth be taken instead of iron, it places itself across the line of the poles, or equatorially, as shown in the figure. By similar experiments Faraday compiled the following list:

*Paramagnetic*: Iron, nickel, cobalt, platinum, manganese, chromium, etc.

*Diamagnetic*: Bismuth, antimony, zinc, cadmium, mercury, platinum, silver, copper, gold, arsenic, uranium, etc., phosphorus, sulphur, iodine. The salts and oxides were also examined, and it was found that compounds of iron, nickel, and cobalt behaved paramagnetically, with the



exception of ferrocyanide of potassium, which is diamagnetic. To examine liquids more readily, Plücker made the tops of his magnet poles flat, and placed upon them, so as to bridge the polar gap, watch glasses holding the liquids. The paramagnetic fluids assumed the form shown

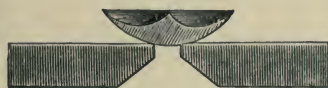

Fig. 264.—Paramagnetic liquid

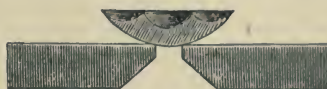

Fig. 265 —Diamagnetic liquid.

in Fig. 264; the diamagnetic fluids, the form in Fig. 265. Water proved to be strongly diamagnetic.

It is a peculiar phenomenon, but one which might be expected when our attention has been directed to the important part played by the medium, that magnetic bodies appear to change their character when the surrounding medium is altered. For instance, paramagnetic bodies surrounded by a more paramagnetic medium behave diamagnetically; and diamagnetic bodies surrounded by a more diamagnetic medium behave paramagnetically.

Gases and vapours were also examined. Faraday made gases mixed with a little HCl rise between the poles of the electro-magnet; tubes holding various gases set themselves either axially or equatorially. Gases were also enclosed in soap bubbles and thin glass globes. In air most gases proved to be diamagnetic; oxygen,\* however, was paramagnetic. Oxygen enclosed in a thin glass globe is strongly attracted, hydrogen strongly repelled. Flames, too, are influenced. Weber constructed an instrument, the diamagnetometer, by means of which he measured the magnetic moment of bismuth; and he found it to be  $\frac{1}{1,500,000}$ th part of that of a piece of iron of the same size.

The behaviour of the various solids when immersed in different media may be explained by considering the relative permeabilities of the body and the medium, and assuming that if the solid be free to move it will set itself so that the reluctance of the magnetic current is a minimum. For the truth of this assumption there is strong experimental evidence. Thus a bar of iron placed between the poles of a magnet will tend to span the gap and to set itself axially so as to offer the path of least reluctance to the magnetic lines of force. Diamagnetic bismuth, however, with a permeability less than that of air will, for a similar reason, set equatorially, because in this position the path provided for the magnetic flux has less reluctance than if the bar of bismuth were set on the line of the poles, where it would displace the more permeable air in the densest part of the field where low reluctance is of the most importance.

\* Professor Dewar, in 1892, very strikingly showed that liquid oxygen is strongly paramagnetic.

Similarly, if a diamagnetic body be placed in a diamagnetic medium, the position it will take up will necessarily depend upon which of the two is most diamagnetic, *i.e.* has least permeability. If the medium be the more diamagnetic, then the body will behave paramagnetically, and similarly to, but much more feebly than, a piece of iron of the same size and shape. But if the body be the more diamagnetic, then it will behave diamagnetically, in accordance with the conditions for least reluctance. The polar properties apparently developed need scarcely be considered.

Spheres made of magnetic substances assume no distinct position between the poles of a magnet, as their mass is regularly distributed in all directions; if, however, balls be made of certain crystals, they will arrange themselves with their optic axes either axially or equatorially. Faraday, who attributes this phenomenon to a peculiarity which the crystals possess, calls it magnecrystallic force, but it may be explained by assuming different permeabilities along and across the optic axis.

#### VI.—EFFECTS OF TEMPERATURE.

The effects of temperature on the magnetic properties of the three magnetic metals, iron, nickel, and cobalt, are remarkable. When heated each of them eventually becomes non-magnetic for all practical purposes, but the temperature at which this occurs is different in each case. For iron the temperature is about  $780^{\circ}$  C., which is a bright red heat, and sufficiently high to make it difficult to arrange for accurate measurements of the temperature and the magnetic effects. The subject has been studied experimentally by Kohlrusch (1887), Hopkinson (1889), Le Chatelier (1891), Morris (1897), and others.

Dr. Morris, in his experiments, used strips of the best charcoal iron, exceptionally pure, wound to form an iron ring; in this ring was embedded a platinum wire, by the changes in the resistance of which the temperature of the ring could be conveniently measured. The ring was then over-wound with three platinum wire coils: (*a*) a coil which was to serve as a *magnetising* coil, (*b*) a coil outside the last to serve as a *heating* coil, by having a sufficiently large current passed through it, and (*c*) a coil to act as a *search* coil for measuring **B** (see page 285). The wires of the coils were carefully covered with asbestos paper to insulate them, and the same material with mica in addition was used to insulate the windings and coils from one another. In this way insulation was obtained capable of resisting the high temperatures at which ordinary insulating materials would have been charred and ruined.

The results of some of the experiments are given in Fig. 266 as a series of curves, in which the temperature is plotted horizontally, and the corresponding permeability  $\mu$  ( $= \frac{B}{H}$ ) is plotted vertically. Each curve

is for a definite value of the magnetising force  $H$ , this value being marked on the curve. The high value of the permeability at temperatures just below the critical one, at which the magnetic properties so mysteriously disappear, is very remarkable for some values of the magnetising force. Thus, for  $H = 0.153$  at a temperature of  $764.5$ , the permeability  $\mu = 12,660$ , but at  $20^\circ$  higher is less than  $100$ . Though thus reduced almost to the vanishing point as compared with its immediately preceding values, and so much so that it cannot be shown on the scale of Fig. 266, the permeability is still measurable. Its value for temperatures higher than the critical one is shown on a much larger scale in Fig. 267, in which the common curve for all values of  $H$  is continued from  $800^\circ$  to  $1,200^\circ$  C. For another annealing at  $840^\circ$  the values of  $\mu$  above that temperature were zero. The results are for a specimen carefully annealed at  $1,150^\circ$  C. The curves show how very complicated the phenomena are, and how dependent the value of  $\mu$  is on both  $H$  and the temperature. It also depends on the physical state of the iron, for the curves for the same specimen annealed at  $840^\circ$  C. instead of  $1,150^\circ$  C. are distinctly different, although the general effect is the same. The attempt to evolve order out of such apparent chaos would appear to be hopeless.

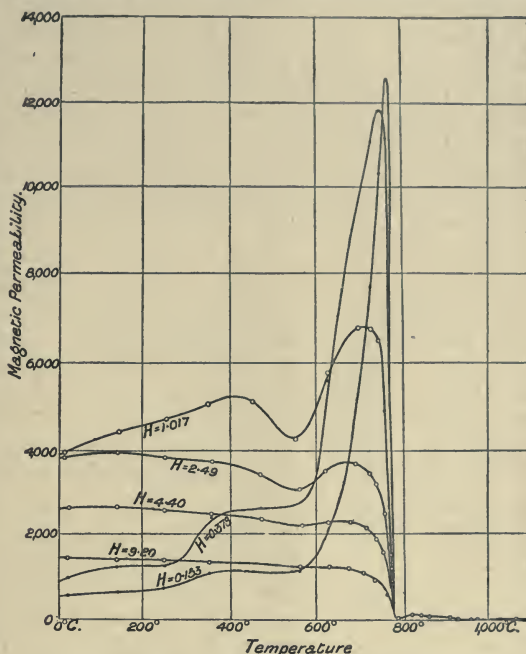

Fig. 266.—Influence of Temperature on Permeability of Iron.

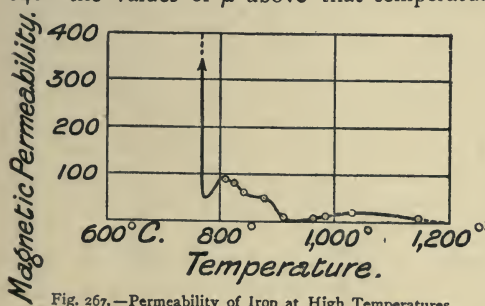

Fig. 267.—Permeability of Iron at High Temperatures.



*Recalescence.*—The temperature above which iron practically loses its magnetic properties, sometimes referred to as the *critical temperature*, is one at which profound molecular changes take place in the material. The magnetic properties are not the only ones affected, for the electric resistance changes more rapidly than usual about this temperature, and the thermo-electric properties are considerably modified. The most striking phenomenon of all, however, is that known as *recalescence*, which can be readily and simply observed by watching a sheet of white hot iron cool in a darkened room. At a certain moment, the cooling iron suddenly brightens up again, and afterwards cools down gradually to blackness in the usual way. The temperature at which the brightening occurs is known as the *temperature of recalescence*, or *re-heating*, and the sudden brightening indicates that, owing to some molecular change, sufficient energy has suddenly been set free in the cooling iron to raise the temperature temporarily, notwithstanding the fact that heat energy is being rapidly lost by radiation all the time. The interesting point is that before recalescence the iron was non-magnetic, and that afterwards it has become magnetic. It is very suggestive that in the magnetic state the material appears to have less molecular intrinsic energy than when it is non-magnetic but at the same temperature.

The hardening of steel by tempering is a well-known industrial process, and great skill and experience are exhibited in choosing the exact temperature at which to "quench" the heated metal in order to procure the right effect. Quite recently it has been discovered that the temperature of recalescence is for many purposes the best temperature for quenching, and this is not surprising in view of the molecular changes at this temperature referred to above. To ascertain when the temperature is reached in the process of cooling a "magnetic gauge" has been invented.

#### VII.—CHANGE OF LENGTH OF MAGNETISM.

In 1837 Page observed that when a piece of iron was magnetised by an electric current in its neighbourhood, a sound was emitted by the iron on the current being turned on or off. These sounds, which in the hands of Reis in 1861 led to the invention of a telephone receiver, are evidently due to molecular disturbances, and were shown by Joule in 1847 to be accompanied by a distinct lengthening of the magnetised rod by about  $\frac{1}{720,000}$ th part of its original length. The sounds and the changes of length, especially the latter, have been experimentally examined since Joule's time by Pogendorff, Tyndall, Alfred Mayer (1874), Barrett (1882), Shelford Bidwell (1885), Nagaoka (1894), Shaw and Laws (1901), and others. Exact information regarding them is of great theoretical interest, as tending to throw light upon the behaviour of the molecules of magnetic materials when under the influence of magnetising forces. The actual changes, however, are so minute that it is only by making use of the most refined methods known to modern science that reliable numerical data can be obtained.

The apparatus used by Bidwell is shown in Fig. 268. The rod *R* of iron experimented upon was 10 cm. long and was magnetised by the coil *D*. The lower end of the rod rested on the movable flap *F*, and its exact vertical position could be adjusted by the fine-threaded screw *S*. The upper end of the rod supported at *B* a lever whose fulcrum was at *A*; the far end of the lever engaged with a short arm *C* fixed to the back of the mirror *M*. A beam of light from *L* being thrown on to the mirror and reflected on to a fixed scale *E*, any movement of the mirror could be detected and measured by reading the position of the reflected spot on the scale. If now the length of the

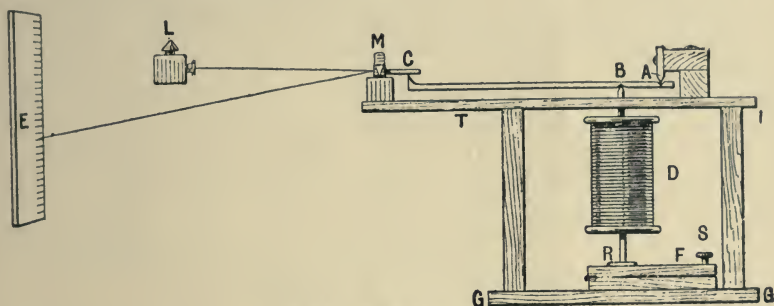

Fig. 268. — Bidwell's Apparatus.

rod *R* is slightly altered when the current passes through the coil *D*, the extent of the alteration, whether an extension or a retraction, will cause an enormously magnified movement of the spot of light on the scale *E*. The scale used was divided into  $\frac{1}{40}$ ths of an inch, and one division of the scale corresponded to a change of length of the rod *R* of 0.000041 of a centimetre.

Very numerous experiments were made with this apparatus, the rods being sometimes replaced by rings. The general results for the three magnetic metals, iron, cobalt and nickel, are well shown in Fig. 269, which is copied from Bidwell's paper in the *Philosophical Transactions* for 1888. The magnetising force, which was carried to very high values, is plotted horizontally, and the elongations and contractions vertically, the former above the line *ox* and the latter below that line. The unit of change of length used is one ten-millionth ( $\frac{1}{10,000,000}$ ) of the whole length. In the particular specimen of iron used there was observed for low values of *H* an elongation which, as *H* was increased, rose to a maximum and then diminished, until at *H* = 300 there was no change of length. For higher values of *H* there was contraction, the amount of which continuously increased to the highest value of *H* (= 1375) which was used. Cobalt behaves in exactly the opposite way to iron, inasmuch as it first contracts and then elongates, the maximum con-

traction, about  $\frac{1}{200,000}$ th of the length, occurring at  $H = 380$ , and the point where there is neither contraction nor elongation being reached

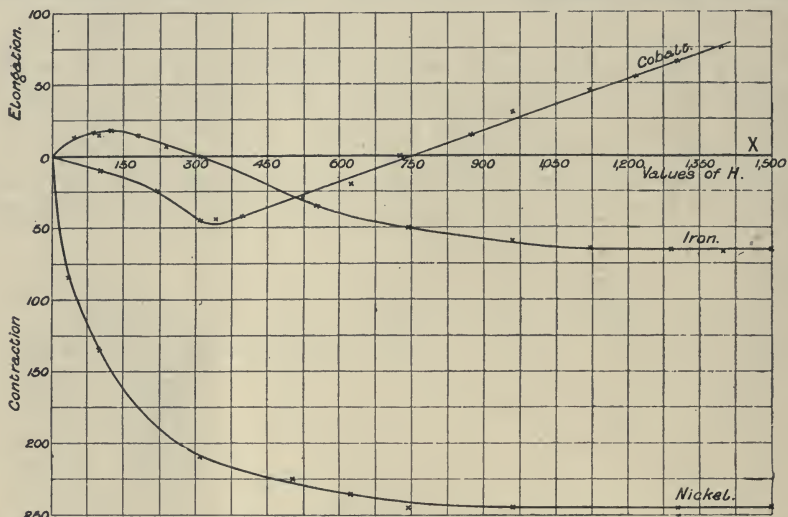

Fig. 269—Changes of Length on Magnetisation.

at  $H = 750$ . Nickel differs from the other two magnetic metals in that it always contracts by an amount which increases with the increase of  $H$ , somewhat rapidly at first and afterwards more slowly. The change of length is also much more considerable than with iron and cobalt, being  $\frac{1}{43,000}$ th of the length when  $H = 500$ , and  $\frac{1}{41,000}$ th for  $H = 1375$ .

Nagaoka, in 1894, examined the effects of cyclic changes of magnetisation on the length of the body magnetised, and observed some very curious and complicated hysteresis effects. Figs. 270 and 271 embody some of his results. The diagrams are plotted in the same manner as Fig. 269. In Fig. 270, which deals with iron, we see the effects of varying  $H$  cyclically between the limits  $+300$  and  $-300$ . Starting from 0 the iron at first elongates to 27 and then shortens to 9 at  $H = 300$ . The magnetising force  $H$  being now diminished and then reversed until it reaches the value  $-300$ , the changes of length are given by the curious curve  $bcdefgk$ . Again diminishing  $H$ , reversing and increasing so as to complete the cycle, the curve follows the path  $lmnopqrs$  to  $b$ . Successive cycles between the same limits of  $H$  give the closed curve  $bcdefgklmnopqrsb$ , the arrows showing the direction in which the curve is swept out.

Fig. 271 gives the curve for nickel between the limits  $H = +30$  and  $H = -30$ , the arrows giving the direction in which the closed loops are formed. As all the changes are contractions, the curve is entirely below the zero line  $xx'$ .



More recently the subject has been again investigated by Messrs. Shaw and Laws, who use for the magnification and measurement of the

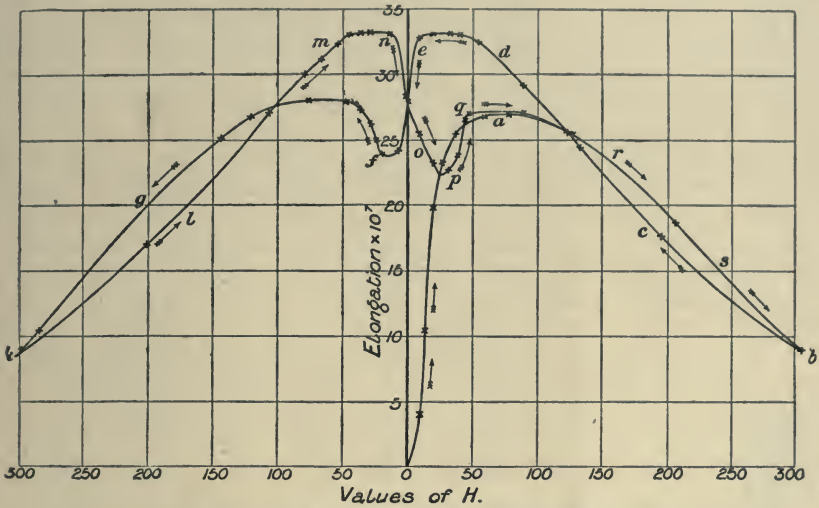

Fig. 270.—Cyclic Changes of Length on Magnetising Iron.

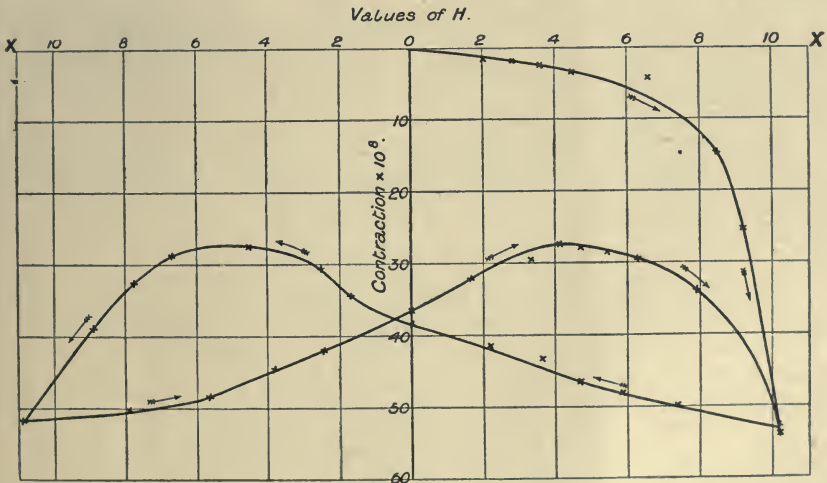

Fig. 271.—Cyclic Changes of Length on Magnetising Nickel.

lengthening of the magnetic material an instrument which they call an "Electric Micrometer." The principle will be understood from Fig. 272,

where  $M C$  is the magnetising coil surrounding a core of the metal experimented upon. The lower end of the experimental rod carries an iridio-platinum plate  $b$ . A contact bead  $a$  faces  $b$ , and the gap  $a b$  when closed completes an electric circuit, in which a telephone is inserted which gives notice to the observer of the exact moment when the circuit is closed. The contact bead  $a$  is fixed to one arm of a lever which is the last of a series of six levers numbered 1 to 6; at the other end of the series the long arm of No. 1 lever rests against the contact point of a micrometer screw  $Sc$ , the head of which  $A$  is divided in the usual manner. As the screw is turned so as to raise the left-hand arm of lever No. 1 the bead  $a$  rises, and the ratio between the movement of  $Sc$  and the movement of  $a$  can be determined. The method of using the instrument is to take readings of the position of  $a$  at which the circuit of the telephone is closed before and after the magnetising current is turned on. The difference between the two positions will measure the elongation or re-

traction of the core of  $M C$ . It is claimed that a movement of the twentieth of the millionth of a centimetre ( $5 \times 10^{-8}$  cm.) can be detected.

Messrs. Shaw and Laws generally confirm the results of previous experimenters, but they consider

they have detected a retraction in iron preceding the elongation at low magnetisations. They

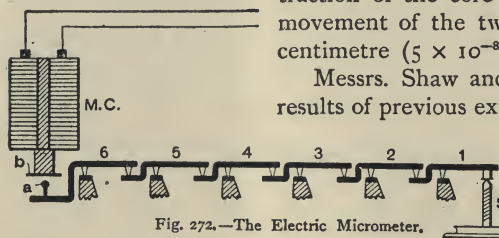

Fig. 272.—The Electric Micrometer.

have also investigated the influence of thickness on the amount of change of length in various fields.

In all the experiments hitherto recorded the experimenters have been content to trace the connection between the magnetising field  $H$  and the changes of length. A far more interesting point for investigation is the relation between the magnetic flux density  $B$  and the changes of length.

#### VIII.—MAGNETIC PROPERTIES OF ALLOYS.

In the preceding pages the magnetic materials dealt with have been chiefly the materials, iron, nickel, and cobalt, as used under these names for ordinary purposes and therefore seldom in the state which a scientific chemist would describe as pure. The results given must be regarded as setting forth the behaviour of the materials which one is accustomed to deal with, as these metals, except in those cases where a definite specification is given. For instance, ordinary samples of iron are contaminated with various impurities, either originally present in the ore and not removed during the metallurgical processes to which the ore has been subjected, or deliberately introduced during those processes. The great variety of such samples which is available for various purposes is due partly to the

presence of these impurities and also, in large measure, to the heat treatment to which the material has been subjected.

The effect of the impurities and of the heat treatment upon the mechanical properties and structure of the material is a subject which has been very assiduously investigated of late years, and a great mass of results has been accumulated, detailed reference to which is outside the province of this book. That the magnetic properties are profoundly affected is evident from the preceding pages, more especially in the steels, which differ from iron chiefly by the presence of small quantities of carbon. It is not surprising, therefore, that one of the results of alloying the magnetic metals with one another or with non-magnetic metals should be a modification of the magnetic properties of permeability, hysteresis, etc. What, however, is surprising is the extent and direction of the modifications, which are such that no working theory at present available will enable us to predict them in any given case without having recourse to experiment. We proceed to consider some such cases.

**Nickel-Iron Alloys.**—One of the most remarkable results of this kind is produced by alloying the two magnetic metals, iron and nickel. Many years ago now it was found that the very hard alloy known as nickel-steel, produced by adding about 25 per cent. of nickel in the process of steel-making, was almost devoid of magnetic permeability, the value of which in both strong and weak fields was found to be about 1·4 as against the values for various kinds of iron and steel given in the curves on page 289. Thus by adding one good magnetic metal to another an alloy is produced whose magnetic properties for all ordinary purposes are negligible.

**Other Iron Alloys.**—As far back as 1885 it was observed that a specimen of steel containing 15 per cent. of manganese was almost unmagnetisable, the amount of magnetisation developed in the specimen by a large electro-magnet being about one eight-thousandth part of the magnetisation developable in good magnet steel. The manganese was added in the form of ferro-manganese to the molten steel during manufacture. Further investigations enabled Mr. Hadfield to produce a manganese steel containing 12 per cent. of manganese and 1 per cent. of carbon, whose permeability ranged between 1·3 and 1·5 in strong and weak fields.

Quantitative results for a number of alloys of iron are given in the curves shown in Fig. 273, which is taken from a paper read in 1902 by Professor Barrett, Mr. Brown, and Mr. Hadfield before the Institution of Electrical Engineers, and published in the *Journal of the Institution*. The curves show the permeability of various alloys when tested in a constant field having the moderate intensity  $H = 8$  c.g.s. units. The vertical ordinates give the permeability, whilst the horizontal ones indicate the percentage of the added metal or element, the highest percentage being about 31.



Taking carbon first, the great difference produced by converting iron into steel by the addition of a small quantity of carbon is given by the curve on the extreme left of the figure, marked "carbon." The curve is only taken as far as about 1.3 per cent. of added carbon, but the con-

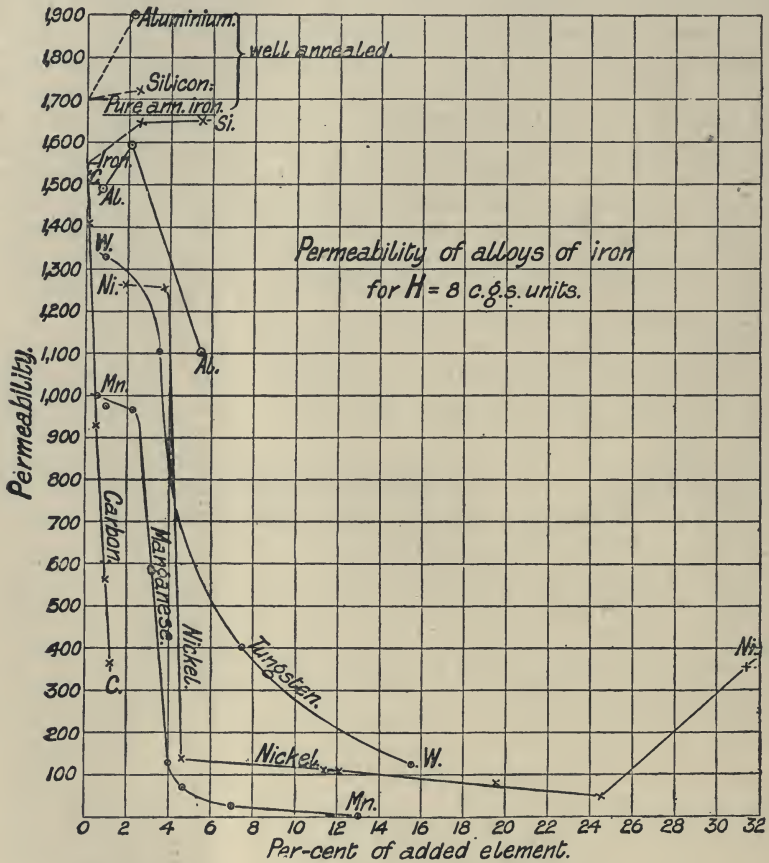

Fig. 273.—Effect on the Permeability of Iron produced by adding various metals.

tinuous reduction in the permeability ( $\mu$ ) as the carbon is increased is very marked. The difference in the magnetic properties of iron and steel have, however, been fully dwelt upon already.

Silicon, on the other hand, has the opposite effect of increasing  $\mu$ , though the change is not very great, but it is maintained in one of the curves up to an addition of 5.5 per cent. of the added element.

Turning now to the metallic alloys, the curves for nickel and manganese show a small effect for low percentages of the foreign metal, but a very great effect for a small additional percentage after a certain point is reached; in fact, the line for nickel is at one place nearly vertical. After this great fall the diminution proceeds at a more leisurely rate with the increase of the added metal, and at about 13 per cent. the value of  $\mu$  sinks practically to zero in the case of manganese. Nickel, on the other hand, reaches a minimum at about 24.5 per cent., after which the value of  $\mu$  rapidly rises. The addition of tungsten gives similar effects, but the changes are not so violent.

The case of aluminium is very remarkable, inasmuch as the addition of a small percentage of this non-magnetic metal produces an alloy which is more permeable than the iron from which the alloy is made. Two results are shown in which the addition of 2.25 per cent. of the foreign metal very markedly increases the permeability. In weaker magnetising fields the result is still more marked. Thus with a field  $H = 0.5$  C.G.S. a certain sample of Swedish iron gave  $\mu = 2,500$ , but when 2.25 per cent. of aluminium was added the value rose to  $\mu = 9,000$ . Beyond 2.25 per cent., however, the addition of aluminium leads to a diminution of  $\mu$  as is shown in Fig. 273.

Space will not allow the effects on hystereses to be given in detail, but they are equally remarkable, and it may be noted that silicon and aluminium alloys have been produced giving smaller hystereses losses than good transformer iron.

**Alloys of Non-Magnetic Materials.**—As a contrast to the unmagnetisable alloys consisting in great part of magnetic materials, magnetisable alloys have been more recently discovered made up entirely of metals which in their separate state are unmagnetisable, some of the constituents, in fact, being diamagnetic instead of paramagnetic (*see* pages 302 and 303).

The existence of such alloys was discovered in 1904 by Heusler, Stark, and Haupt, and since their discovery they have attracted the attention of many investigators, including Mr. Hadfield, Professor Fleming, and others. The alloys originally experimented upon consisted of manganese, aluminium, and copper, none of which are paramagnetic; and in fields varying from 20 to 150 units for  $H$  the values of  $B$  were found to be from 60 to 5,000 units, thus giving values of  $\mu$  up to over 30, a value sufficiently high for a fairly heavy specimen to be supported by the poles of a horse-shoe magnet.

Since the above initial results were published these alloys have been minutely examined by numerous experimenters in various countries and from different points of view. They are found to possess most of the usual properties of magnetic materials, such as a magnetisation curve bending

over for the higher flux densities, a permeability curve rising to a maximum and then falling away, hysteresis, etc. Being alloys, the varying composition of the different specimens leads to different numerical values of the magnetic quantities, which are also affected by the presence of other metals, the influence of lead being specially marked. They are also much affected by the heat treatment they are subjected to, and under certain conditions of temperature and previous heat treatment can be obtained in the non-magnetic state, in which it is worth noting that their density is very different from that which they have in the magnetic state. Thus

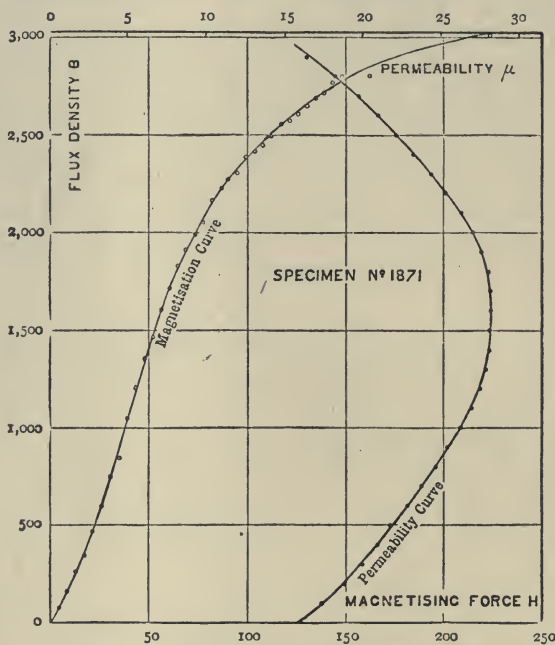

Fig. 274.—Magnetisation and Permeability Curves of Copper Alloy.

a certain alloy which when originally cast was strongly magnetic ( $H = 75$ ,  $B = 11,800$ , and  $\mu = 157$ ), and had a density of 6.61 after annealing at  $950^{\circ}\text{C}$ ., was found to be non-magnetic and to have a density of only 5.80.

It is impossible to deal with all the results obtained in detail, but the curves given in Figs. 274 and 275 will suffice to show how the magnetic properties resemble those of iron. These curves are taken from a paper by Professor Fleming and Mr. Hadfield, read before the Royal Society. Fig. 274 gives the magnetisation and permeability curves of a particular specimen, the former being plotted as usual with values



of **H** horizontal and values of **B** vertical, but the latter being plotted somewhat differently from usual practice, with the values of  $\mu$  horizontal against the values of **B** vertical. A series of hysteresis loops for the same specimen are given in Fig. 275, and may well be compared with the similar loops for iron given in fig. 259. Finally, the dependence of hysteresis

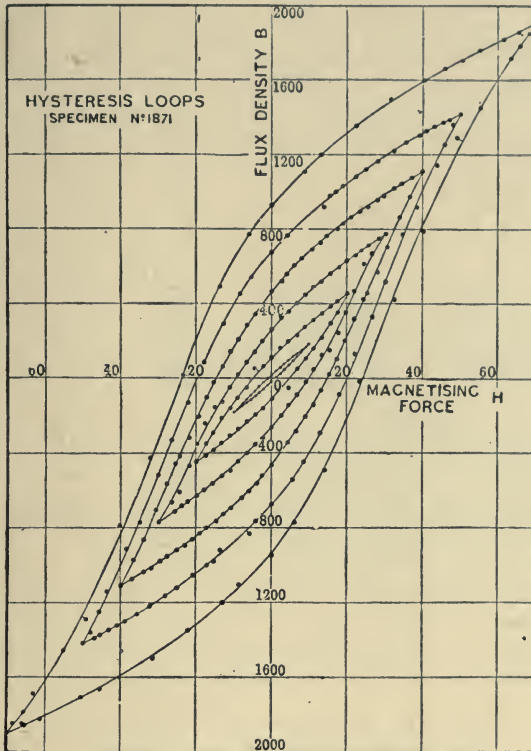

Fig. 275.—Hysteresis Loops of Copper Alloy.

on flux density is given in Fig. 276. These curves show that the connection between the losses per cycle per cubic centimetre and the maximum flux density follows a law similar to Steinmetz's law for iron, which has been referred to on page 296. Expressed in symbols, the loss is:

$$w = c B^x$$

where  $w$  is the loss,  $B$  the flux density, and  $c$  and  $x$  are constants, whose value can be determined from the curves.

The composition of the particular alloy experimented upon was:

Manganese	...	...	...	...	...	...	...	...	Per cent.
Copper	...	...	...	...	...	...	...	...	22.42
Aluminium	...	...	...	...	...	...	...	...	60.49
Carbon	...	...	...	...	...	...	...	...	11.65
Silicon	...	...	...	...	...	...	...	...	1.50
Iron	...	...	...	...	...	...	...	...	0.37
Slag (MnO and SiO <sub>2</sub> ), say	...	...	...	...	...	...	...	...	0.21
									3.00
									<u>99.64</u>

There was, therefore, only a mere trace of iron present.

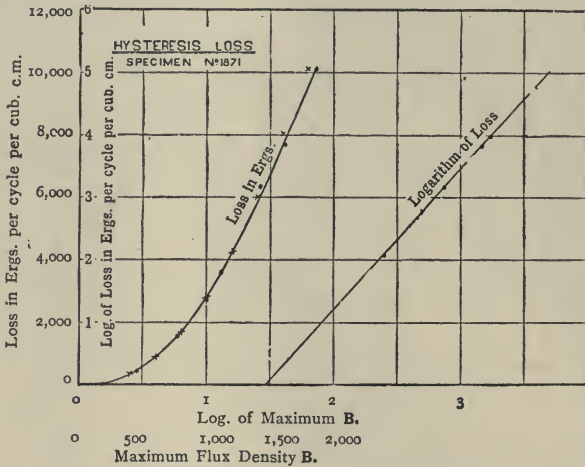

Fig. 276.—Hysteresis Losses in Copper Alloys.

Attempts have been made to account for these results by supposing that a particular crystalline form is essential to the magnetic state, and that this form is produced in these alloys; but as yet there is little, if any, evidence to give us a clue to the correct explanation.

IX.—MAGNETISM AND LIGHT.

Connecting links between different physical phenomena are always interesting, and frequently lead to important results and theories regarding the nature of the phenomena. Thus, electricity and magnetism, at first distinct sciences, are now known to be intimately associated. It is therefore not surprising that physicists should have early attempted to find some connection between the phenomena of magnetism and of light, and it is worthy of note that their efforts have been successful.

There are at least three ways in which magnetism has an effect on a beam of light. The first, discovered by Faraday in 1845, is the rotation of a beam of plane polarised light when traversing a transparent medium in the direction of the lines of a magnetic field. The second, discovered by

Kerr in 1877, is again concerned with plane polarised light, which is rotated when reflected from the polished pole of a magnet. Lastly, in 1896, Zeeman found that the well-known D lines of the spectrum are profoundly modified in appearance when the light passes through a powerful magnetic field.

**The Faraday Effect.**—A ray of light is said to be polarised when it can be reflected at the surface of glass in one position, but not in another; or when it can be transmitted through a plate of tourmaline in one position, but not when the plate is turned at right angles to this position. Ordinary light can be reduced to this condition by passing it through what is called a polarising apparatus. A Nicol prism or a thin slice of tourmaline will answer the purpose. The plane in which a ray is polarised can be detected

by observing it through a second polarising apparatus (Nicol prism or tourmaline). Every polariser is opaque to rays polarised in a plane at right angles to that plane in which it would itself polarise light. Hence, of two such pieces, one polarises the light, and the other tests the light and shows it to be polarised. The first is called the polariser, the second the analyser. The nature of polarised light has been previously referred to in describing (*see* page 66) experiments on the electrostatic strains in a dielectric.

Faraday caused a polarised beam of light to pass through a piece of certain "heavy glass" lying in a powerful magnetic field between the poles of a large electro-magnet, through the coils of which a current could be sent at pleasure. Under these circumstances he found that the plane of polarisation was *rotated* in a marked degree.

This rotation of the polarisation plane may be shown by means of the apparatus represented in Fig. 277, as arranged by Ruhmkorff. The electro-magnets *N S* are placed horizontally, with their poles opposite to each other. The iron cores of the magnets are bored through their whole length. The iron yoke which connects the two iron cores consists of three pieces, *E*, *H*, and *E'*. The two pieces *E* and *E'*, bent at right angles, are movable on the horizontal piece *H*, so as to alter the distance between the two poles. The commutator *c* reverses the current at will. When

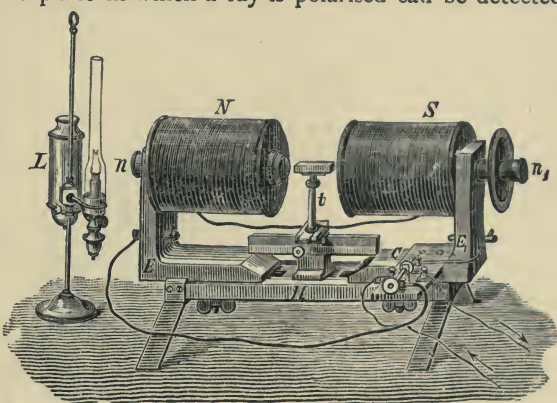

Fig. 277.—Action of a Magnet on Polarised Light.



rotation of the polarisation plane is to be observed, the polariser is placed at  $n$ , in the bore of the iron core; the analyser, which carries a divided circular scale, is placed at  $n_1$ . The source of light is placed at  $L$ , and the body under examination upon  $z$ . The two Nicols (polariser and analyser) are then so arranged that the field of vision remains dark when the magnets are unexcited; if now contact is made, the field of vision again becomes bright, and the angle through which the analyser has to be moved to produce darkness again, gives the amount of rotation of the plane of polarisation by the magnet. The amount of rotation was shown by Verdet to be proportional to the strength of the field and the

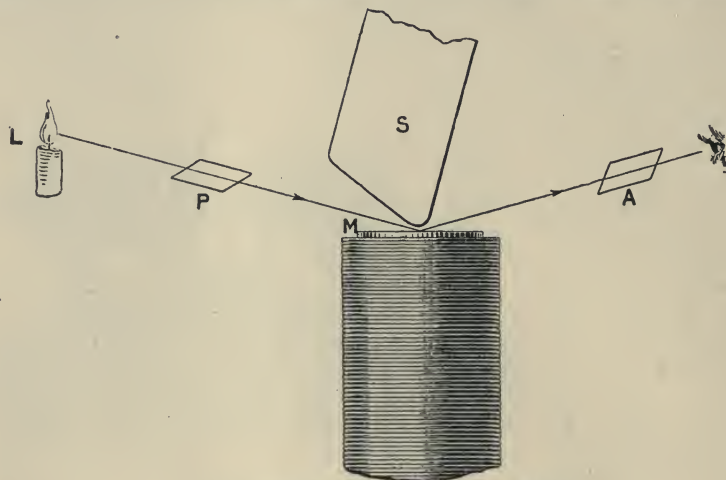

Fig. 278.—Oblique Reflection from Pole of Magnet.

length of the column of liquid or transparent medium. Most isotropic substances of high refractive power are found to rotate the plane of polarisation when placed in the position indicated in Fig. 277.

**The Kerr Effect.**—In 1877 Kerr directed a beam of plane polarised light on to the polished pole of a powerfully excited electro-magnet, and found that the plane of polarisation of the reflected light was rotated. The arrangement of the apparatus for oblique incidence of the light is shown in Fig. 278, where the light proceeding from some source  $L$  is first passed through the polarising prism  $P$  and then reflected at the polished pole  $M$  of the magnet. After reflection it is examined by the analysing prism  $A$ . To increase the magnetic effect at the point where the light strikes, a sub-pole  $s$  of soft iron is brought close down to the polished surface so that the beam passes through a narrow magnetic gap.

For perpendicular incidence Kerr used a sub-pole  $s$  (Fig. 279), which had a hole  $a a$  bored through it, and which was kept from coming

in contact with the pole of the magnet *M* by wooden distance pieces. The light from *L* after passing through the polariser *P* was reflected downwards from a sheet of unsilvered glass *G*, placed at an angle of  $45^\circ$ ; after reflection from the polished pole of the magnet, the part of it transmitted through *C* was examined by the analyser *A*.

The chief result of these experiments is thus stated by Dr. Kerr:—  
 “When plane polarised light is reflected regularly from either pole of an iron electro-magnet, the plane of polarisation is turned through a sensible angle in a direction contrary to the normal direction of the magnetising current; so that a true south pole of polished iron acting as a reflector turns the plane of polarisation right-handedly.”

Dr. Kerr also examined a beam of light reflected obliquely from the side of a polished magnetised bar, which formed the armature of an electro-magnet. In this case also he found that the plane of polarisation is rotated, but the rotation is in opposite directions according as the original plane of polarisation is parallel or perpendicular to the plane of incidence of the light.

**The Zeeman Effect.**—The observation of this effect depends upon the use of somewhat refined optical methods, and in describing it some elementary knowledge of optics must be assumed. It is generally known that when the light of an incandescent vapour is examined spectroscopically, the spectrum is not continuous, but is found to consist of a series of more or less numerous bright bands. Now, if such a source of light be placed between the poles of the Ruhmkorff electro-magnet (Fig. 277), the bands can be observed in the usual way, and are unaffected as long as the magnet is unexcited. Confining the observation to a single band, let the magnet be now strongly excited. On examining the light transmitted through the pole pieces, that is, *along the lines of force*, the band is *split into two* very close together, and circularly polarised in opposite directions. In other words, the vibrations in the two bands are circular ones and the rotations are in opposite directions. The separation of the two shows that the wave lengths are slightly different.

Let the light now be viewed at *right angles to the lines of force*, say horizontally from the side of the magnet. In this case the band is found to be *split into three*, all of which are plane polarised—that is,

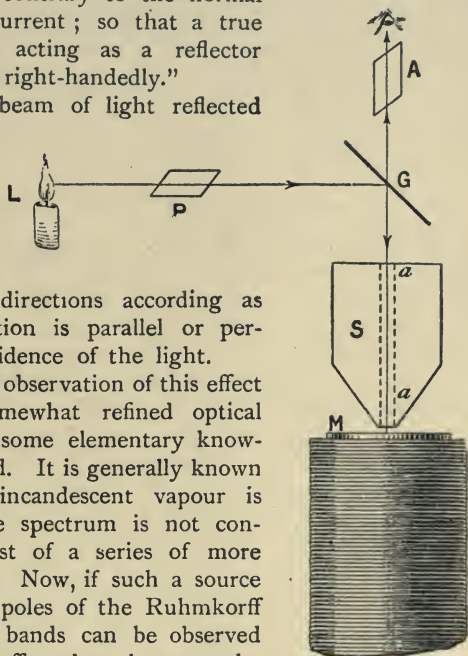

Fig. 279.—Normal Reflection from Pole of Magnet.

consist of vibrations in definite planes. Further, the vibrations of the central band, which is of the same wave length as the original light, are horizontal—that is, along the lines of force; whilst the vibrations of the side bands are vertical—that is, across the lines of force. These two side bands, of course, have wave-lengths slightly greater and slightly less respectively than the central band.

It is therefore proved that there is a direct action between a magnetic field and the vibrations which constitute light. If we suppose that the vibrating atoms of the source carry positive and negative charges of electricity, the above effects can be explained by the well-known electro-magnetic laws which we have been considering, and even the ratio of the charge of electricity to the mass of the vibrating atom or "corpuscle" can be measured. It is considerations of this kind that make the phenomena of such high theoretical importance.

#### X.—THEORIES OF MAGNETISM.

**The Two-fluid Theory.**—The earliest speculations, subsequent to Gilbert, of any scientific value regarding the nature of magnetism, were promulgated at a time when Newton's great discovery of the law of gravitation had directed the thoughts of philosophers to theories postulating action at a distance. It was not, therefore, surprising that some explanation, analogous to that which had so brilliantly simplified our conceptions of the laws governing the motions of the heavenly bodies, should be put forward to explain the actions which were observed in the magnetic field. A very superficial consideration of the facts, however, would suffice to show that the phenomena were more complicated than those of gravitation. In the latter it was only necessary to assume that particles of matter *attracted* one another according to a certain law. But in magnetic working both attractions and repulsions had to be explained. The difficulty was met by assuming the existence of *two* magnetic materials with diverse properties, such that like particles repelled and unlike particles attracted one another, with forces proportional to their magnetic masses and inversely as the square of the distance between them. From the extreme mobility shown in the experiments, these magnetic materials were assumed to be *fluids*, and hence arose the *two-fluid theory* of magnetism.

This theory, as most frequently set forth, assumed that the surfaces of magnets were coated, as it were, with the appropriate magnetic fluids, the density varying from point to point of the surface as was required to explain the experimental facts. It gave rise to many elegant and abstruse mathematical theorems, which have been very useful in the development of pure mathematics, and which, up to a certain point, explained some of the early experiments and enabled the results of



others to be predicted. The inherent difficulties were, however, great, for apart from their curious properties the assumed fluids were found by experiment to be quite imponderable, and to be non-existent apart from magnets. Moreover, if magnetism were some kind of fluid which flowed over from the one body to the other during the process of magnetisation, we should have expected to observe some signs of magnetisation in the wood, glass, or pasteboard sheet which we placed between the iron bar and the magnet; but these did not show any signs of magnetisation. Again, the piece of iron magnetised should have only one kind of magnetism, depending upon which pole of the magnet touched or was near the piece of iron; but this it was observed was not the case. Lastly, the magnet should lose some of its power at each experiment, and, on the other hand, the piece of iron should give signs of magnetisation when removed from the magnet, at least for some time.

These considerations taken alone would not perhaps have overthrown the theory, but as fresh facts were accumulated it began to break down in its attempts to explain them. Thus, Jamin showed in his experiments with corrosives that magnetism is not only distributed along the surface of a body, but enters it more or less according to the constitution of the body. He found that a magnet may possess several layers of magnetism, differing from each other, and he obtained what he termed abnormal magnets, that is, magnets with two north poles, or two south poles. He took a normal magnet, magnetised its outer layer oppositely to the inner, so that he had now a south pole where formerly there was a north pole. The new north pole of his magnet was brought into contact with some acid, which removed the outer layer of the magnet. When examined this end showed its original magnetism, that is, south. The remaining pole of the magnet, that is, the south pole, was not put into acid, and it remained south. This magnet, then, had two south poles.

Earlier still, experiments made with broken magnets tended to show that the surface distribution of magnetic fluids is insufficient as an explanation of the facts. Thus, if we break a long thin magnet, such as a magnetised knitting-needle, or a thin bar N S (Fig. 280), at the middle, or neutral line, we obtain two magnets, each of which has a

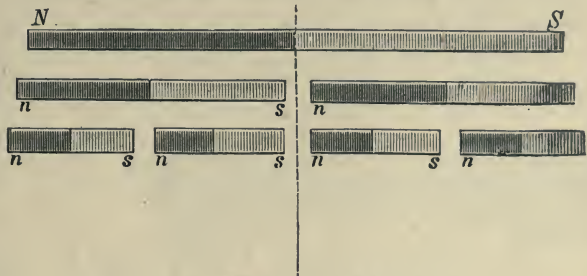

Fig. 280.—Effects of Breaking a Magnet.

north- and a south-seeking pole. Let these two pieces be again broken, then each of the smaller pieces thus obtained will be a magnet, both its ends attracting filings, while the north-seeking pole points in the same direction as the north-seeking pole of the original magnet, and the south-seeking pole in the same direction as the south-seeking pole in the original magnet, as shown in the figure. If we consider these breakings to be continued till the portions become infinitely small, we are led to the conclusion that a magnet consists of little parts, or molecules, each of which possesses a north- and a south-seeking pole, and that all the north-seeking poles lie in one direction and all the south-seeking poles in the opposite direction. There is a free north-seeking pole at one end and a free south-seeking pole at the other, but every intermediate north-seeking pole is neutralised by the presence of an adjacent south-seeking pole.

**Poisson's and Weber's Theories.**—In the earlier molecular theories, notably one put forward by Poisson, it was assumed that the process of magnetisation consists in magnetising the individual molecules, whose axes would then be arranged as just described. This, however, only forces the difficulty one step farther back, as it is perhaps more difficult to imagine a process of molecular magnetisation than one of magnetisation of the whole mass.

Most subsequent theories assume the molecules to be already magnetised. One of the earliest of these was advocated by Weber, who, in addition, assumed that the molecules were subjected to a constant controlling force. According to this theory, it is not difficult to explain some of the different magnetic phenomena we have noticed, as, for instance, the action of magnetic induction. If we bring a piece of iron *a b* near the north-seeking pole of a magnet *S N* (Fig. 281), all the north-



Fig. 281.—Magnetic Induction.

seeking ends of the molecules of the magnet are directed towards the piece of iron, and as they are nearer than their south-seeking poles, their influence therefore prevails. The molecules of the piece of iron, which are first scattered through its mass with their poles pointing in all directions, when under this induction turn their south-seeking poles towards the magnet. The end of the piece of iron nearest the magnet will exhibit magnetism opposite to that of the pole to which it is presented.

According to this view, magnetisation is nothing more than a determinate position of all the molecular magnets, all their north-seeking poles pointing in one direction, whilst their south-seeking poles point in the opposite direction. A piece of iron is in an unmagnetised condition

when the molecules assume various and mixed directions. This may be illustrated by a simple experiment. If we nearly fill a glass tube with steel filings which have been magnetised, and pass the pole of a magnet along the tube several times, the tube of filings will behave like any ordinary bar magnet. The filings are now turned with their poles facing the same way, but if we shake the filings in the tube it loses its magnetism, as the poles of the particles of filings are no longer turned in the same direction. The following experiment is even more striking. A glass cylinder is fitted with flat glass ends, and is filled with water in which magnetic oxide of iron is diffused. A coil of insulated wire is wound round the cylinder. On looking at a light through the ends, the liquid appears muddy, and very little light can get through; but when a current of electricity traverses the wire, the liquid appears clearer and more light passes. The reason is that the particles of the oxide on being magnetised arrange themselves so that their lengths are in the direction of the axis of the cylinder, and so they obstruct the light less. In a similar manner the existence of the neutral zone may be explained. When we bring a piece of iron near the middle of a magnet, as at  $m m'$  (Fig. 282), it is not influenced, because there are an equal number of particles on each side of that line having poles producing equal and opposite effects.



Fig. 282.—Magnet and Iron Filings.

But this theory, although it goes much farther than the two-fluid theory, still fails to account for all the facts, and more especially it does not explain all the peculiarities of the curves of magnetisation such as we have given in Figs. 252 and 254. According to the assumption made with respect to the nature and direction of the supposed constant controlling force, these curves would have different forms, but none of the theoretical forms would correspond with the actual curves. Subsequent philosophers have therefore added further assumptions tending to bring the theory into closer correspondence with the experiments. The difficulty is to account for the three stages (Fig. 283) shown in these curves, namely, the slow initial rise from zero, the subsequent very rapid rise, and the final gradual rise. Except that the points  $a$  and  $b$  are not so sharply defined, careful experiment shows that magnetisation curves are made up of the three parts  $o a$ ,  $a b$ , and  $b c$ . Indeed, if we smooth the angles as shown by the dotted line, we get quite a typical curve. Any theory of magnetisation must account at least for these three stages and also for the phenomena of residual magnetism and hysteresis as already described.

**Wiedemann's and Maxwell's Theories.**—To meet the difficulty Wiedemann assumed the turning of the molecules to be hampered by



a frictional resistance similar to the friction between two solids. The peculiarity of such a resistance is that it absolutely prevents motion until the moving force reaches a certain magnitude beyond which the

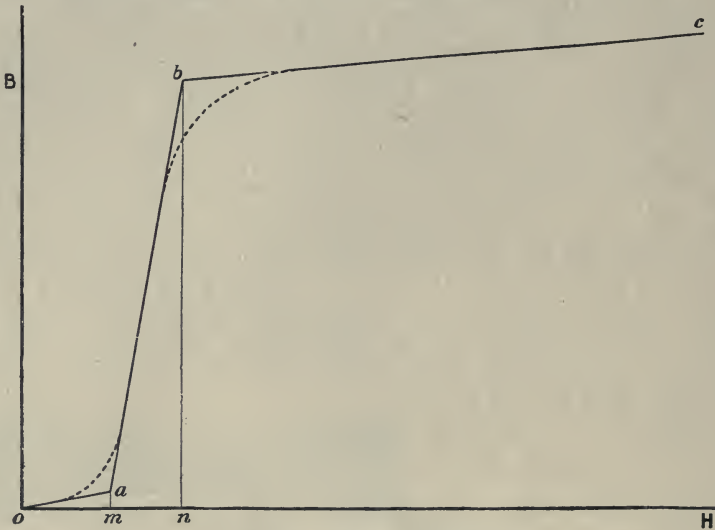

Fig. 283.—Stages of Magnetisation.

motion produced rapidly increases. This would account for the part  $a b$  (Fig. 283) of the curve, but not for the other two stages.

Maxwell improved upon this hypothesis by assuming that the molecules rotated under the influence of the magnetising forces in the same way that an elastic solid such as steel yields to mechanical forces. If a piece of steel wire is stretched by a gradually increased mechanical pull it at first yields but a very little, until a certain strain is reached known as the elastic limit. Within this limit it has the power of elastic recovery, and will return to its original length if unloaded. This stage corresponds to the part  $o a$  of the magnetisation curve. After the elastic limit is passed the material yields very rapidly and non-elastically to comparatively small increases in the load, and we have a stage corresponding to the stage  $a b$  of the magnetisation curve. Beyond this the mechanical analogy cannot be pressed, as the stretched wire ultimately breaks. But in the magnetisation case we are dealing with rotations which cannot be carried beyond a certain line, namely, the direction of the magnetising field. We can therefore get over this final difficulty by supposing that the greater number of molecules yield non-elastically during the period  $a b$ , but that some of the molecules or molecular groups do not so yield until the magnetising field has

passed the value  $o n$ . If they after that yield a few at a time, we may account for the small increases registered in the stage  $b c$ .

Residual magnetism is explained by assuming that even at the highest magnetisation some of the molecules have not lost the power of elastic recovery, and that these resume either partially or entirely their original positions when the magnetising field is suppressed; their contribution to the magnetisation thus disappears with the field. The remaining molecules, having been strained beyond the elastic limit of recovery, remain permanently set, and their changed orientation causes the residual permanent magnetisation.

Since the elastic limit and the power of elastic recovery may be assumed to differ widely in different materials, this theory accounts for a wide range of experimental facts. It is difficult, however, to see how the existence of hysteresis can be explained by any reasonable extension of the theory.

**Hughes's Theory.**—Prof. D. E. Hughes, so well known in connection with the microphone, exhibited, in 1884, experiments in support of a theory that in an unmagnetised piece of iron or steel the molecules assumed to be magnetised are arranged in closed magnetic chains. Taking 20 flat strips of iron bound together, he first magnetised them in a strong field, and suppressed the field. He then dissected the compound bar and tested the separate strips, which were found to be magnetised in various complicated ways, sometimes even oppositely to the general magnetisation of the laminated bar. Following a method used by Jamin, Hughes dissolved in weak nitric acid an iron bar which had been subjected to magnetising forces. As successive layers of iron disappeared the bar showed curious opposing states of magnetisation at different thicknesses. This Hughes explained by supposing that the molecules of iron removed by the acid had formed part of closed magnetic chains, which, by the removal of some of the molecules, had become opened, and thus affected the external field. Hughes also showed how his theory explained the fact that thin steel bars are better for permanent magnets than thick ones.

**Ewing's Theory.**—Ewing, assuming that the elementary molecules of magnetic materials are individual magnets, supposes that in the unmagnetised state these elementary magnets are not scattered through the mass of the iron in an utterly irregular manner, but that they form molecular magnetic groups by the mutual influence of the magnets on one another. Such a group, like Hughes's closed chain, produces no outside magnetic force. A set of molecular groups, each containing four magnetic molecules, is shown in Fig. 284, the molecules being denoted by arrows whose heads are turned in the direction of the molecular magnetic axis. The first and third group  $a$  and  $c$  would exert no external magnetic effect, but the other two would exert, the second  $b$  a horizontal magnetic effect, and the last  $d$  a vertical effect. The transition from

stages *a* and *c* to stages *b* and *d* can be brought about by subjecting the magnets to the influence of an external field.

In Fig. 285 we have a set of molecular groups, each consisting of seven molecules. In each of these the various magnetic axes are so disposed by the mutual magnetic action that on the whole little or no outside magnetic effect could exist. Suppose, now, a gradually increasing magnetic

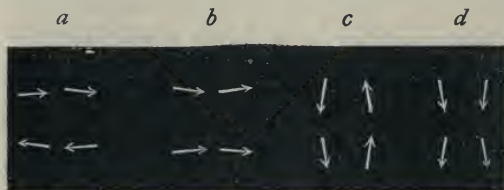

Fig. 284.—Groups of Four Magnets.



Fig. 285.—Groups of Seven Magnets.

field is produced in the space where such groups exist within an unmagnetised iron bar. Whilst the magnetic force is feeble it has little effect, and only a few of the molecular magnets will move in response to it, producing a slight external magnetic effect in the direction of the field. This stage corresponds to the portion *o a* (Fig. 283) of the ordinary magnetisation curve. If the field be now suppressed these disturbed magnets will return to their original positions and no permanent magnetisation will remain. If, however, instead of suppressing the magnetic field its strength be increased gradually, then sooner or later some of the molecular groupings will become unstable, and a little further increase of the field will overpower the mutual actions of the magnets; the groups so disturbed will then be broken up by the turning of the individual magnets more or less completely in the direction of the magnetising force. As the magnetic field increases still further, more and more groups are thus broken up until practically none of the original groups remain. This stage corresponds to the part *a b* of the magnetisation curve (Fig. 283), and on the suppression of the magnetic field many of the magnets would retain their positions; the bar would be permanently magnetised.

If now the strength of the field be further increased, even to a great extent, very little additional magnetic effect can be produced, for the molecular magnets are now all setting in the general direction of the magnetising field, and all that can be done is to bring them more strictly into line with the field against the elastic resisting forces due to mutual magnetic actions. The magnetisation of the bar will be increased, but not to any great extent. This stage corresponds to the part *b c* of the magnetisation curve (Fig. 283), and on the removal of the field the magnets will return to the position denoted by *b*.



To illustrate his theory, Ewing experimented with groups of little pivoted magnets, and some of the results of an experiment with 36 such magnets are shown in Figs. 286 to 288. In each figure the direction of the superimposed magnetic field is shown by the arrow  $h$ . In Fig. 286 the magnets appear to be unaffected by the field  $h$ ; they are grouped in a number of closed chains. On the magnetic field  $h$  being increased the groupings become unstable, and break up one after another until we have the magnets in the position shown in Fig. 287, in which all the north-seeking poles are turned in one direction, but the magnetic axes are not quite parallel to  $h$ . It is exceedingly interesting to watch the successive changes intervening between Figs. 286 and 287; it must, of course, be remembered that the pivots upon which the magnets turn are fixed in lines which are not parallel to  $h$ . On still further increasing the strength of  $h$  considerably the individual magnets are brought into the positions shown in Fig. 288, in which the magnets are dragged nearly parallel to the direction of  $h$  against the mutual magnetic forces acting between neighbouring magnets.

With such groups of magnets Ewing was able to show effects corresponding to those

produced in magnetising an iron bar, not only as regards the general shape of the magnetisation curve already alluded to, but also with regard to retentivity, coercive force, hysteresis, etc. He therefore advanced the theory that the mutual magnetic actions according to known laws between the magnetised molecules rendered unnecessary the hypothesis of a frictional resistance to the turning of the molecules when subjected to the influence of a magnetising field.



Fig. 286.



Fig. 287.

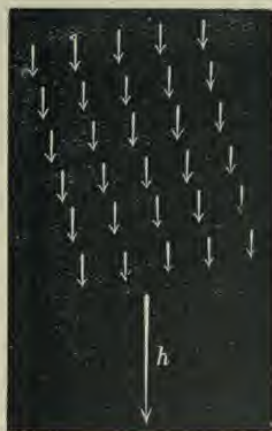

Fig. 288.

Ewing's Experiments with Groups of Magnets.

**Ampère's Theory of Magnetism.**—All the theories (except Poisson's) hitherto mentioned begin by assuming that the magnetic molecules are actually magnetised, but none of them give any indication of how such magnetisation was originally effected or how it is retained. The evident similarity in the behaviour of magnets and solenoids led to *Ampère's theory of magnetism*. Solenoids and magnets obey the same laws. The force of attraction or repulsion between their poles is directly proportional to the product of the pole strengths and inversely proportional to the square of the distance. Solenoid and magnet affect each other exactly as two magnets would. These phenomena led Ampère to give up the two-fluid theory, and to suggest that magnetism is nothing else than parallelism of electric currents. By means of Ampère's theory all magnetic phenomena find a simple explanation; a magnet may be assumed to consist of a bundle of molecular solenoids, with their similar poles arranged in the same direction. Such currents if looked at from one end of the magnet

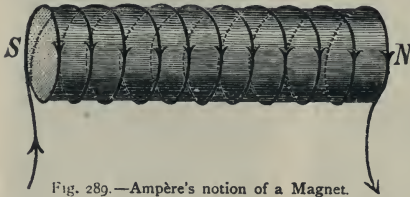

Fig. 289.—Ampère's notion of a Magnet.

would all appear to be circulating in the same direction, and their joint effect could be represented by a single current circulating in that direction round the magnet. According to Ampère's theory, this resultant current at the south pole of a magnet will flow clockwise, at the north pole counter clockwise, the pole in question pointing towards the observer.

If the observer stand before the south pole of the solenoid (Fig. 289), the current enters at s, and flows without altering its direction of rotation through all the turns, and out again at n. Place a watch with its face towards the observer, the current will move with the hands; if now the observer moves to face the north pole, still having the watch facing him, he will see the current move against the hands of the watch. If every kind of magnetism (earth magnetism too) be due to electrical currents, it must be the earth currents which determine the position of the magnet or solenoid. The current which causes the earth's magnetism must flow from east to west, and the current at the south pole of the magnet has the same direction at its lower side, and the opposite direction at its upper side.

The molecular electric currents, if they exist, do not cause any evolution of heat as do the currents in our ordinary electric circuits. If, however, the molecular circuits have no resistance, no heat can be generated, and, moreover, the current, when once started, would continue to circulate until suppressed by external causes. It is not easy to see how the currents are originally started. A piece of iron, for instance, at a white heat cannot be magnetised, and therefore we must assume that its molecules are not magnets, and that the Ampèrian currents are non-existent in

them. As the iron cools it suddenly, at the temperature of recalescence (page 306), becomes magnetic, and therefore during the violent energy changes which take place at this temperature the Ampèrian currents must be generated. How this is accomplished has not yet been suggested, but if energy has to be used in the process there are certainly at this temperature sufficiently large changes taking place in the intrinsic energy of the molecules to allow of some being available for the generation of the currents.

The phenomena of diamagnetism can be explained by assuming that molecular currents are started in channels of no resistance by the inductive action of the field in which the experiments are made. According to the laws of magneto-electric induction, the direction of circulation of these currents would be such as to set up a field opposed to the inducing field, and the observed repulsions, etc., would follow. On the removal of the inducing field, currents would be induced in the opposite direction, which would cancel the previous currents, and the body would return to its original condition with its molecules unmagnetised. Ewing has pointed out that this theory requires the molecular groups of diamagnetic bodies to have enormous rigidity as compared with iron or steel.

In view of the new facts which have been brought to light by Heusler's discovery of magnetic alloys composed of non-magnetic materials (*see* page 313), and by the experiments of other investigators in the same direction, it is obvious that the foregoing theories will have to be modified in various directions if they are to give even an approximate explanation of the phenomena. The time, however, has scarcely arrived for a complete re-discussion of these theories, although the data are now rapidly accumulating.



## CHAPTER VIII.

*ELECTRO-MAGNETS.*

In applying the foregoing laws and principles to the service of man, the electro-magnet, in some one of its many forms, plays a most important part. Indeed, to discuss adequately the varied types of electro-magnets and the functions they are called upon to perform, would require the setting down here, in anticipation, much of what will constitute a considerable portion of the subsequent sections of this book. There are, however, certain general principles and considerations involved in the design and use of electro-magnets which may be conveniently referred to here and illustrated by the description of a few typical designs, some of which are very widely used.

The principle which conduces more than anything else to the usefulness of an electro-magnet is the fact that its magnetism can be set up or removed at pleasure, and that the position from which this operation can be effected may be at a very considerable distance from the point where the magnet is situated. The place where the electric circuit, the current in which controls the magnetism, is made or broken, can be placed anywhere in the circuit, and, as a rule, the length, disposition and extent of this electric circuit can be adapted to any conditions. The limitations which economical and other considerations place upon this statement will appear in the sequel under particular cases are being dealt with, but the main principle is of paramount importance. It involves as a consequence the possibility of creating, suppressing, varying and controlling mechanical forces of predetermined magnitude and direction at a great distance from the operator. These forces can be used either directly, if large enough to perform the work to be done, or they may be applied indirectly, as a trigger is used in a gun, for the purpose of setting in motion a much larger store of energy and thus controlling work which may be immeasurably beyond their own feeble powers. In whatever way they are used, however, the electro-magnet, with its wonderful properties, is the key of the arrangement, and without it the whole train of operations might have to be modified, and in many cases the results attained would be impracticable.

Since the most usual and immediate object of an electro-magnet is the production or variation of a mechanical force, and since the mechanical force between two magnetic materials in the neighbourhood of one another is proportional to the square of the magnetic flux (or lines of force pass-

ing from one to the other), we see that in designing an electro-magnet great attention should be paid to the production of the necessary magnetic flux as readily as possible. The same consideration also applies when the primary object of the electro-magnet is the production of an intense magnetic field in a confined space, as in the air-gaps of dynamo machines. In both cases the object will be attained by so disposing the copper of the electric circuit and the iron of the magnetic circuit that the desired effect on the latter shall be produced most economically by the means available in the former. These two circuits are always linked together as shown diagrammatically in Fig. 290, which illustrates the simplest possible case of a magnetic flux being set up in an iron ring by a current-carrying ring looped through it in a plane at right angles to the plane of the iron ring.

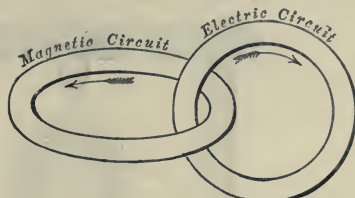

Fig. 290.—Relative positions of Electric and Magnetic Circuits.

The laws directly involved have been dealt with already, but it may be well to recapitulate them here in a slightly different form. The magnetic flux produced will depend upon :

- (1) *In the Electric Circuit.*—The magneto-motive force (M. M. F.), which is proportional to the “ampere-turns”—that is, to the product of the current by the number of turns in the magnetising spirals.
- (2) *In the Magnetic Circuit.*—The reluctance ( $\lambda$ ), which should be as low as possible. This is attained by making the circuit as short and as thick as possible, and by introducing into it as much magnetic material of high permeability as the circumstances will permit.

It is well also to bear in mind the relations between the direction of circulation of the current and the direction of the magnetic flux. This relation is shown again in a different form, but one more adapted for our present purpose, in Fig. 291, where the arrowheads on the dark outer circles indicate the direction of circulation of the electric currents, and the letters N and S on the shaded inner circles show the polarity of the near ends of iron cores round which such currents circulate.

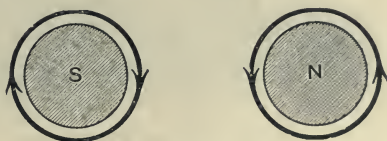

Fig. 291.—Relation between Current Circulation and Poles of Core.

It is only necessary to remember in addition the convention that the direction of the magnetic flux is *outwards* from a *north-seeking* pole and *inwards* towards a *south-seeking* pole. Attention is called to the corkscrew rule already given (*see* page 276), which will be found to harmonise with

Fig. 291. It may perhaps be well to emphasise the fact that it is the *direction of circulation* of the current which determines the direction of the flux, and that it is a matter of perfect indifference whether the magnetising solenoid be wound in right-handed or left-handed spirals.

In most cases, the function of an electro-magnet is to produce motion of some kind, and therefore the complete apparatus usually consists of two parts, fixed and movable respectively. In one of Sturgeon's early electro-magnets, already illustrated (Figs. 247 and 248), the fixed part is the

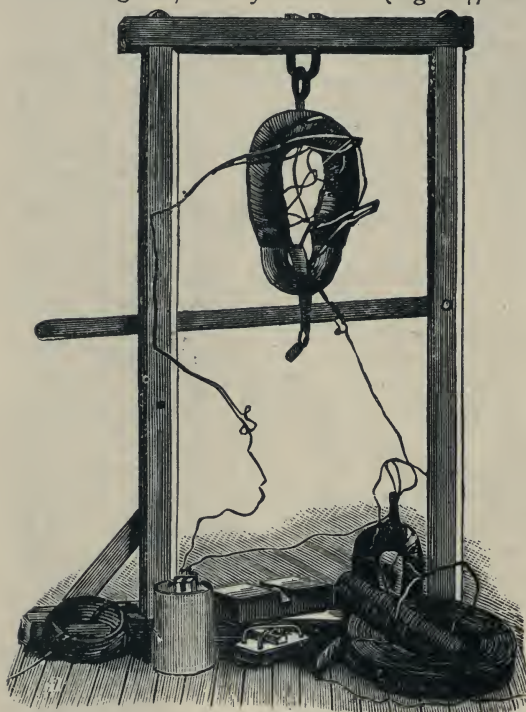

Fig. 292.—Henry's Electro-magnet.

horseshoe-shaped piece of iron overwound with the magnetising coil, and the soft iron keeper, or armature, is the movable part. In the straight bar magnet of Fig. 249 no movable part is shown. By the kindness of Professor S. P. Thompson we are able to illustrate in Fig. 292\* another electro-magnet of great historic interest, namely, the electro-magnet used in 1831 by Professor Henry, of Princeton College, in his original investigation which resulted in the discovery of the "law of ampere-turns." The internal rod of soft iron, technically called the *core*, is 20 inches long and 2 inches square, weighs 21 lb., and is bent into the form of a horseshoe,  $9\frac{1}{2}$  inches high. Nine coils in all were wound on the core, and each coil consisted of 60 feet of copper bell-wire carefully insulated, the ends of the coils being brought out so that any desired combination of them might be made. The ends of the core and the parts of the armature in contact were properly surfaced so as to fit well together, and, the whole being fixed in a strong wooden frame as shown, a wooden lever was arranged passing through a loop fixed on the armature. By sliding weights along the lever the forces of detachment corresponding to particular variations of the magnetising coils and

\* Copied from the *Scientific American* of December 11th, 1880.



currents could be ascertained. The small single-fluid copper-zinc battery shown at the foot was used in the experiments. With one coil only in circuit, Henry found that the force produced was only just able to support the 7-lb. armature. As successive coils were added the force required to detach the armature rose rapidly at first and afterwards more slowly, until with the whole of the nine coils in circuit a force of 650 lb. weight was required to pull off the armature. A later electro-magnet, built by Henry in 1831, was capable of supporting a load of nearly a ton weight (more exactly 2,063 lb.) on its armature. The apparatus shown was mostly constructed by Professor Henry himself, and in addition to the electro-magnet comprises a current-reverser, and some of the coils used in his experiments on secondary and tertiary induction currents, to which we shall refer later on.

**Short-range Electro-magnets.**—Passing to modern forms of electro-magnets, we have in Figs. 293 and 294 examples of the lineal descendants

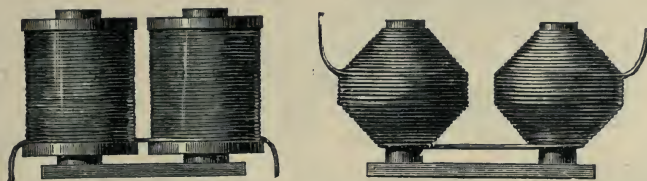

Figs. 293 and 294.—Two-limb Electro-magnets.

of the old horseshoe type first used by Sturgeon and Henry. The curved part of the horseshoe, difficult to make and overwind with wire, is replaced by two straight cores connected by a carefully fitted *yoke* piece, which serves to carry the magnetic flux across from one core to the other. On these cores the magnetising coils can either be wound directly, as shown in Fig. 294, or, being previously wound on proper formers with bounding flanges, can be easily slipped on the cores as shown in Fig. 293. The conical shape of the coils shown in Fig. 294 was devised by Kelvin for cases in which the length of wire used for a definite magneto-motive force was of importance. In neither case is the complete electro-magnet apparatus shown, for the movable part, or armature, is omitted. Its proper position would be such as to bridge magnetically more or less the space between the two exposed poles, but the precise form it must take depends upon the nature of the work to be done. The complete electro-magnet with its armature as used in a continuous current electric bell is shown in Fig. 295, in which *Y Y* is the iron of the yoke and *A A* the armature iron, *P P* being the pole pieces. The only non-magnetic gaps in the magnetic circuit are the short distances between *P P* and *A A*, for stout cores pass through the coils as shown by the dotted lines. The piece *B B B*, which carries the yoke and the armature, is non-magnetic, being made of brass. In

some cheap forms of bells this piece is of iron, which magnetically is a bad design.

For certain kinds of work, more especially where space is a primary

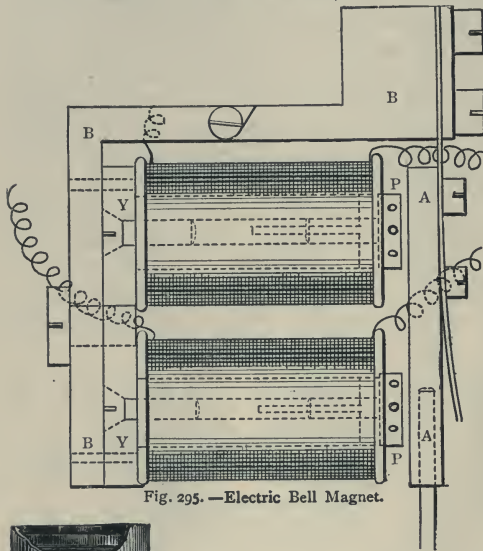

Fig. 295.—Electric Bell Magnet.



Fig. 296.—Ironclad Electro-magnet.

consideration—as, for example, in the fitting up of a large telephone exchange switchboard—one of the magnetising coils is discarded, and the necessary return path for the magnetic flux is provided by an iron sheath of adequate thickness placed round the coil which is retained. The arrangement is shown in Fig. 296, in which a part of the outer iron sheath has been cut away to show the magnetising coil and iron core within. The fixed yoke-piece at one end is shown in section bridging across the bottom between the central core and the sheath, but the movable

armature at the other, which will be disc-shaped in this case, is not shown in the figure. Such magnets are variously known as "ironclad" or "bell" electro-magnets.

Where the object of an electro-magnet is the production and utilisation of a mechanical force, the kind of work which it is called upon to perform must obviously profoundly affect its design. Thus the actual motion required may be small, but within this range of motion it may be desired to produce a comparatively strong force. The magnets just described are suitable for this purpose, since, as usually arranged, the distance between the fixed cores and the movable armature is small, and it is only across this short distance that motion is possible. In fact, the mechanical pull upon the armature diminishes very rapidly as this distance increases, until at quite a moderate distance the pull ceases to have any practical value.

**Long-range Electro-magnets.**—There is, however, another class of electro-magnets in which the range of motion is much greater. In these the iron core of the magnetising solenoid is the movable part, and advantage is taken of the fact already referred to, that in a non-uniform field a piece of soft iron will tend to move to the part of the field where the lines are densest. Another way of stating the same

principle is that whenever part of a magnetic circuit consists of soft iron free to move, the *soft iron will move* in such a direction as to *diminish the magnetic reluctance of the circuit*. The principle of such electro-magnets can be demonstrated experimentally with the apparatus shown in Fig. 297. The core c of the solenoid A is free to move along the axis

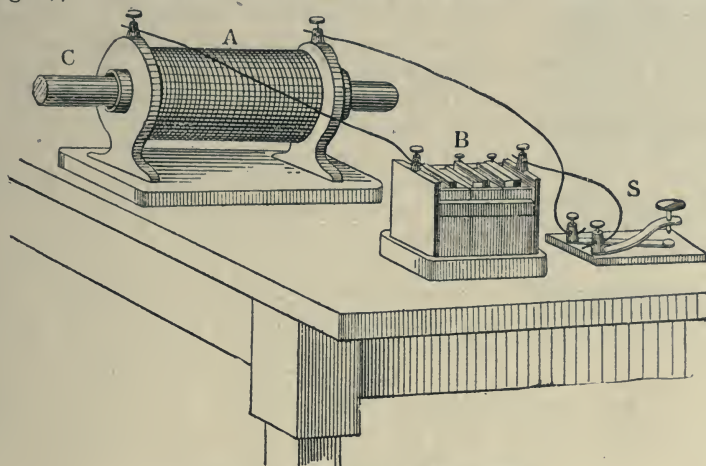

Fig. 297.—Coil and Plunger Electro-magnet.

of the solenoid, and can be withdrawn at pleasure. Let the solenoid be joined up in circuit with a battery B and a break-circuit key or switch s and the core removed. If now the electric circuit be closed at s and the end of c be introduced into the coil, it will be found to be pulled strongly inwards, and that as the core enters the coil the pull increases at first, reaches a maximum, and then decreases until the core, if longer than the coil, lies symmetrically within it, with equal lengths sticking out at each end. If the core be withdrawn a few inches from this position and released, it will oscillate, provided the interior of the solenoid be sufficiently smooth, about the central position, and finally settle down in that position as if it were constrained to do so by elastic bands. With the iron in the central position the magnetic circuit of the field of the solenoid has manifestly the least reluctance.

We see that the force of attraction on the iron core produced by the solenoid is not uniform. As the core approaches the solenoid the force is increased, then again diminishes, until in a certain position the rod remains at rest. This is the case when the centres of bar and coil coincide as shown in Fig. 297, and the force with which an iron core may be drawn into a solenoid, when properly arranged, may become very considerable, a solenoid placed vertically being able to hold an iron core in suspension.



Greater equality of pull than is possible with a solid cylindrical core can be obtained over a long range in two ways. In the first place the coils on the solenoid may be arranged in sections, and as the core moves forward successive sections may be brought into circuit by contacts successively made by the moving core. Or the core itself, instead of being a simple cylinder, may take some of the forms devised by F. Krizik and shown in Fig. 298. The shapes of the three upper cores are obvious. In the two lower ones iron is shown shaded and the white spaces represent non-magnetic material. In all the iron is piled up towards the centre, with the result that as the core moves forward the variation of the reluctance is more gradual and the forces produced are more uniform than with a solid cylindrical core.

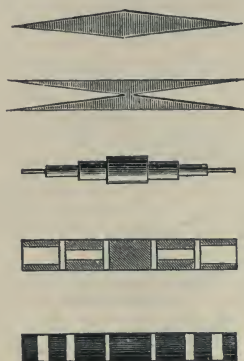

Fig. 298.—Krizik's Bars.

A practical example of a long-range plunger electro-magnet is shown in Fig. 299, which represents the electro-magnet used in one of the early patterns of arc lamps made by the Brush Electrical Engineering Company. In general arrangement it resembles the two-limb electro-magnets already described (Figs. 293 and 294), the modification being that the former armature has been fixed and the cores with their connecting yoke have been made movable. If these cores be now drawn downwards a non-magnetic gap of high reluctance is introduced into the magnetic circuit of the coils. The cores are therefore sucked inwards with a considerable force, and tend to move so as to shorten the non-magnetic gap and diminish the reluctance of the circuit. The same principle is employed in other electro-magnetic devices, which will be referred to in due course.

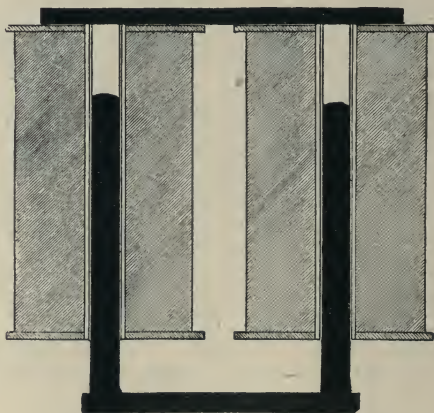

Fig. 299.—Electro-magnet of Brush Arc Lamp.

### Dynamo Electro-Magnets.

—Another large class of electro-magnets has for its primary object not the mechanical effect of a pull on a piece of movable iron, but the production of a more or less intense magnetic field for other purposes. By far the most important section of this class consists of the electro-magnets of dynamo-electric machines, the fundamental principle of which requires that there should be relative motion between

conducting circuits and magnetic fields, the magnitude of the E. M. F. produced depending directly upon the number of lines in the magnetic field. For this reason, and also because the magnets are very frequently of considerable size, the principles on which good magnetic circuits depend are carefully followed in the design. This does not, however, preclude a very great variety in constructional details for special purposes. Only a few forms will be referred to here, as the subject will be more fully considered in a later section.

A widely used form is shown in section in Fig. 300, in which the magnetic circuit is of the horseshoe type inverted. There are two magnetising coils on the upright cores *c c*, which are connected across their upper ends by a very massive yoke *Y*. *N* and *S* are the pole-pieces, and the magnetic circuit is completed by a cylindrical armature of good soft iron which almost fills the space *A* between the pole-pieces. The whole magnet stands upon an iron bed-plate, which, if placed against the pole-pieces *N S*, would deflect many of the lines of force, because these would tend to pass through the good magnetic iron of the bed-plate as the path of least reluctance.

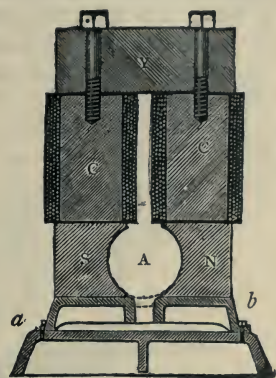

Fig. 300.—Electro-magnet of a Bipolar Dynamo Machine.

Since the main object of the electro-magnet is to force as many lines as possible across the gaps between the pole-pieces *N S* and the armature iron, a non-magnetic foot-step *a b* of zinc, or some other suitable material, is interposed between the pole-pieces and the bed-plate to diminish the magnetic leakage which otherwise would occur through the latter. Notice especially the ample cross-section of all parts of the magnetic circuit and the

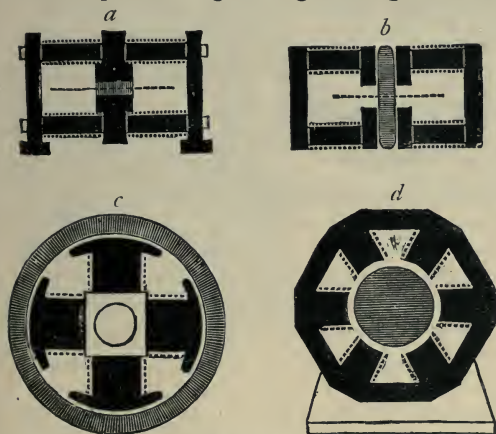

Fig. 301.—Electro-magnets of Dynamo Machines.

reduction of its length so as to leave only sufficient room for the magnetising coils.

To illustrate partly the possible variety attainable, four other forms of dynamo electro-magnets are shown diagrammatically in Fig. 301. In these diagrams, to which we shall have to return later, the heavy black

portions represent the yoke iron, pole pieces, and cores, carrying the magnetising coils, the positions of which are indicated by rows of dots at the side. The iron of the armature is indicated by lighter shading. In both *a* and *b* there are four magnetising coils, the currents in which so circulate as to produce north polarity at the top pole-pieces, and south polarity at the bottom, the lines of force flowing from top to bottom through the armature iron. Both these are essentially two-pole machines, though in the latter there are really four pole-pieces. In *c* and *d*, what are known as multipolar magnets are illustrated, *c* having four poles and *d* six; these poles being alternately north- and south-seeking. In *c* the poles

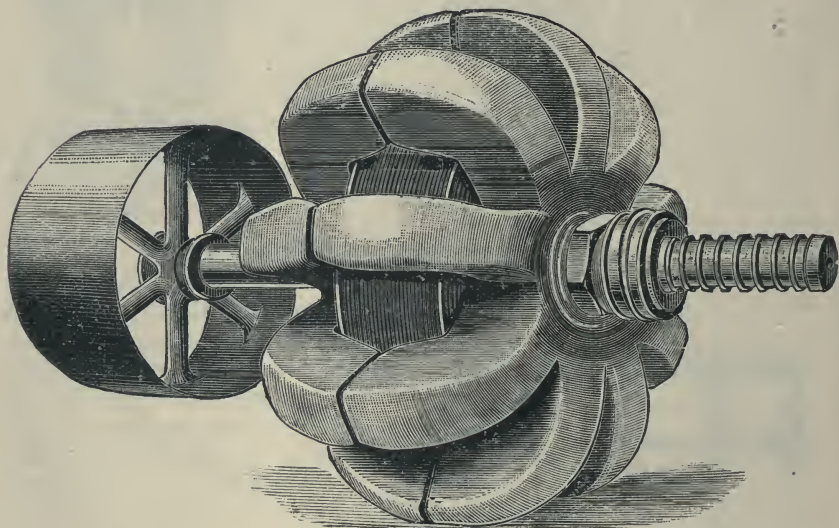

Fig. 302.—Electro-magnet of Mordey Alternator.

are internal, and the armature iron surrounds them in a cylindrical ring, which carries the lines of force from the north-seeking poles to the south-seeking ones on either side. In *d* the poles carrying the magnetising coils project inwards from an external yoke-piece which surrounds the whole of them, and the armature iron is placed in the inner central space.

In another type worthy of notice a single magnetising coil produces a multipolar magnet. It is of importance because large machines have been built with electro-magnets of this general type. Two examples are shown in Figs. 302 and 303. In Fig. 302 we have the electro-magnet of the Mordey Alternator. The magnetising coil can be seen between the arms occupying the central space; from the ends of its core rise the massive polar projections which almost enclose the coil and form a magnet with eighteen poles. The projections on either side very nearly meet.



and the object of the design is to produce a very intense field in the gap between the opposed faces of these projections. It is perhaps needless to point out that the poles on one side, say the right-hand side, are all of one polarity, and those on the opposite side are all of the other polarity. Fig. 303 is even more curious. For clearness only a portion of the magnet is shown in this figure, the complete magnet with its thirty-two poles being as shown in Fig. 304. The magnetising coil, the position of which can be seen in Fig. 303, is wound on a circular framework, which takes the place of the core in the more compact forms. From either side of this framework unsymmetrical polar projections rise alternately, those rising from the left-hand side having, say, north-seeking polarity, and those which rise from the right-hand side having south-seeking polarity. Poles so placed are technically known as "staggered" poles. The iron of the armature is not shown, but it will be readily

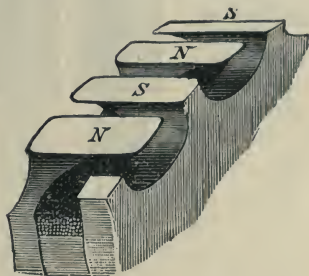

Fig. 303.—Details of Electro-magnet with "Staggered" Poles.

understood that it surrounds the polar faces  $NSNS$  of Fig. 303 in much the same way that the armature iron surrounds the projecting poles in Fig. 301, *c*.

There are many other forms of electro-magnets designed for producing intense fields in a limited space; one of these has been already illustrated in Fig. 263 in connection with the experiments on diamagnetism, and others will appear in the sequel.

**Polarised Electro-magnets.**—There is another widely used class of magnets which consist of permanent steel magnets with which electro-magnets are combined. Since the pole-pieces of such magnets exhibit polarity, due to the permanent magnetism of the steel, when there is no current in

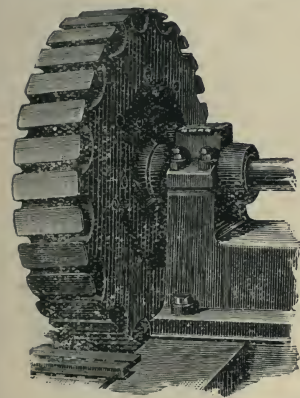

Fig. 304.—Electro-magnet with "Staggered" Poles.

the coils or solenoids they are known as *polarised electro-magnets*. They are very extensively employed in Telegraphy and in Telephony, though the principle is frequently of use in other directions. We select for illustration one from each of the applied sciences named.

Fig. 305 gives two views of the Hughes polarised electro-magnet as employed in the printing telegraph. The permanent magnet consists of four strips of steel of horseshoe shape, highly magnetised, and clamped together to form a single magnet. This method of construction (*see*

page 23) gives a stronger magnet for the amount of material used than if this material were in one solid piece.

On the ends of this compound steel magnet are clamped soft iron pole-pieces  $p$  with cylindrical extensions, which form the cores of the magnetising coils of the electro-magnet. At the further ends of these cores there are additional polar extensions and a movable bridge-piece or armature  $a$ , the rapid alternate attraction and release of which is the object of the arrangement. With no current in the coils  $a$  is held off the pole-pieces by the spring  $s$ , forming the other arm of a bent lever. This spring is set just to counter-balance the pull due to the permanent magnet. In this position it is very sensitive to the additional pull due to

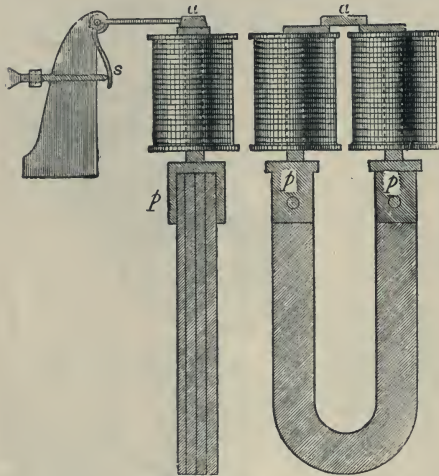

Fig. 305.—Hughes Polarised Electro-magnet.

a small current circulating in the coils, placed on the ends of the pole-pieces. Professor Hughes, by long and patient research, showed that this piling up of the coils on the end of the poles gave *more rapid working* than if they were distributed along the magnet. In the printing telegraph the operating current only lasts about one-hundredth of a second, and therefore the response of the armature must be rapid.

A telephonic example is the polarised electro-magnet of the old Gower telephone shown in Fig. 306. The permanent magnet  $NOS$  is semicircular, the ends of the steel being near the centre of the diameter of the semicircle. To these ends are fastened soft iron pole-pieces, which turn at right angles and project forwards. The coils are wound on the pole-pieces, thus following Professor Hughes's method of construction. The armature, not shown in the figure, consists of an iron plate which closes the box and forms the vibrating diaphragm of the telephone. Its response has to be much more rapid than in the printing telegraph just described.

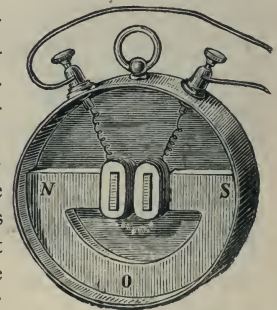

Fig. 306.—Polarised Electro-magnet of Gower Telephone.

The foregoing descriptions do not nearly exhaust even the chief forms of actual electro-magnets, but they deal with the more important types, and well illustrate the principles involved. Further modifications used in actual practice will be referred to as occasion requires.

## CHAPTER IX.

*SIMPLE MEASUREMENTS IN CONTINUOUS CURRENT CIRCUITS.*

A GREAT portion of the advance of electrical science during the last forty years has been due to the establishment and elaboration of a system of exact measurement of the chief quantities involved and universally recognised in all parts of the world. Although different individual workers, especially Gauss and his followers, had previously formulated various methods of measurement, and proposed more or less suitable standards with respect to certain magnetic measurements, the work of international co-ordination dates from the appointment, in 1862, by the British Association of its Committee on Electrical Standards. The work of this Committee, carried on assiduously from year to year, the results being embodied in a series of valuable annual reports, eventually secured the co-operation of leading scientists abroad, and the joint results obtained and suggestions put forward were formally adopted after careful consideration at different international congresses called for the purpose. The progress of science may in the future require the modification and extension of some of the decisions thus officially adopted, but meanwhile the advantages to science of their widespread recognition and practical use have been incalculable. It is therefore essential in considering the services rendered by electricity to mankind that the reader should have a clear grasp of the essential simple principles involved in these measurements and in the construction of the diverse and beautiful instruments by which they are made. In this chapter we propose to deal with some of the units and the simple methods of measurement of most frequent use in connection with continuous current circuits.

## I.—QUANTITY OF ELECTRICITY.

**Voltmeters.**—In dealing with the chemical effect of the electric current we have already pointed out (page 195) that Faraday's laws of electrolysis form the simplest basis for measuring the total quantity of electricity that has passed any given point in an electric circuit during the continuance of the current, provided that the current has always flowed in the same direction. The practical unit in which such a quantity of electricity is measured is known as the *coulomb*, and we repeat here, for convenience of reference, the electrolytic definition of the coulomb previously given.

**Definition of Unit Quantity of Electricity.**—*One coulomb is that*



quantity of electricity which, passing in a definite direction through a silver voltameter, deposits 0.001118 of a gram of silver.

The silver voltameter referred to in the definition is a simple piece of apparatus which may conveniently be constructed as shown diagrammatically in Fig. 307. A shallow dish  $\kappa\kappa$  of thin platinum rests on three metal pins  $m m m$ , and forms the kathode of the voltameter, the metal pins being joined together by wires connected to the wire  $b$ . The anode is a thick plate  $A$  of silver suspended by a strip  $s$  of silver cut out of the same sheet and bent up and connected to the wire  $a$ . The platinum dish is nearly filled with a solution of pure silver nitrate, and when  $a$  and  $b$  are connected to the positive and negative ends of the circuit respectively, the current passes from the plate  $A$  to the dish  $\kappa\kappa$  through the electrolyte. In accordance with the laws of electrolysis already explained, silver is dissolved off  $A$  and is deposited on  $\kappa\kappa$ , the amount of

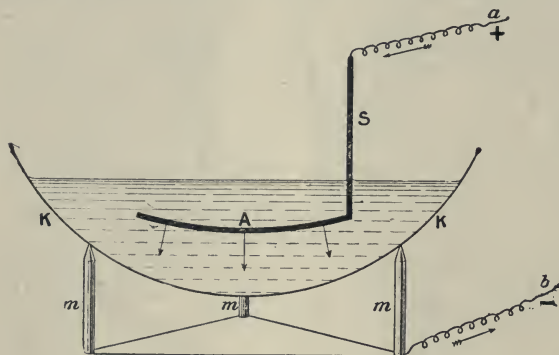

Fig. 307.—Silver Voltameter.

silver either dissolved or deposited being theoretically a measure of the total quantity of electricity passing. In practice, probably because of secondary chemical actions, more accurate results are obtained by weighing the quantity deposited on  $\kappa\kappa$  than by ascertaining the amount dissolved off  $A$ .

Several precautions are necessary; the plate  $A$  should be wrapped in blotting paper to prevent silver oxide from falling on to  $\kappa\kappa$  and being weighed with it. Then again, an *adherent* deposit should be obtained which can be readily washed without loss. Theoretically the rate at which the silver is deposited is immaterial, but in practice, if the current density, that is, the number of amperes per square inch, be too great, the silver may be deposited in a powdery or a non-adherent form which could not be washed, dried, and finally weighed with any degree of accuracy. A current of about one-sixth of an ampere per square inch of kathode surface gives good results, and this density should not be very much exceeded. The washing, drying, and weighing of the dish  $\kappa\kappa$  both before and after the deposition of the silver must be carefully done. The strength of the solution of silver nitrate may vary within wide limits, but a solution of 20 grams of the salt in 100 cc. of pure water gives good results.

The difference in the weights of  $\kappa\kappa$  before and after deposition gives

the weight of silver deposited, and then the quantity of electricity measured can be found by dividing this weight by 0.001118, or

$$\text{Quantity in coulombs} = \frac{\text{weight of silver deposited (grammes)}}{0.001118}.$$

A copper voltameter is less expensive than a silver one, and accurate results can be obtained with it. It can be made by placing two sheets A and K (Fig. 308) of pure copper about half an inch apart in a solution of copper sulphate. One of these, A, the anode, may be fairly thick, as it is not necessary to weigh it, and it will be partly dissolved when the current passes. The other, K, the cathode, should be as thin as possible, both because it will increase in thickness as the copper is deposited on it and also because its *increase* of weight will be used to calculate the coulombs of electricity, and any increase will be more accurately ascertained with a light plate than with a heavy one. The current must, of course, be passed through the voltameter from the anode to the cathode, and great care must be exercised in cleaning and drying the cathode when it has to be weighed, that is, before and after the passage of the current. The quantity of electricity that has passed will be given by the equation—

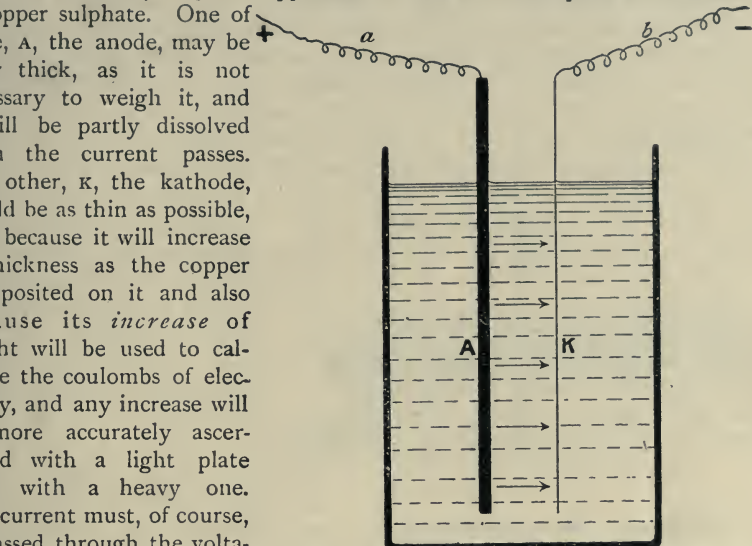

Fig. 308.—A Copper Voltameter.

$$\text{Quantity in coulombs} = \frac{\text{weight of copper deposited (grammes)}}{0.000326},$$

since 0.000326 gramme is the electro-chemical equivalent of copper or the quantity deposited by one coulomb.

In a copper voltameter an adherent deposit can be procured with a much denser current than is safe with a silver voltameter. For copper the current may be as large as half an ampere per square inch of cathode surface. There is a drawback which affects high accuracy in the occasional solvent action of the solution on the copper plates. This can be overcome by careful preparation of the solution, and especially by expelling the dissolved air.

It is possible to use other kinds of voltameters for the measurement

of quantities of electricity, but in each case the proper electro-chemical equivalent of the ion electrolysed must be employed in the subsequent calculation. A table of these electro-chemical equivalents has been given on page 196. Some fairly accurate gas voltameters have been devised, in which the gases evolved in the decomposition of water are measured and the coulombs calculated from this measurement.

**Ballistic Method.**—In practical applications it is frequently necessary to measure accurately quantities of electricity whose magnitude is only a very small fraction of a coulomb. An inspection of the table of electro-chemical equivalents will convince the reader that the accurate measurement of so small a quantity as, say, the ten-thousandth part of a coulomb would be impossible by electrolytic methods, as the weight of metal deposited would be almost, if not quite, inappreciable. In these cases, however, the electricity to be measured can usually be so dealt with that it can be passed almost instantaneously through a suitable galvanometer, the result being that the movable part of the galvanometer receives an impulse the effect of which can be measured. This effect then becomes a measure of the quantity of electricity that has passed through the instrument. The details of this method, which, for reasons that will appear in due course, is known as the *ballistic* method, will be more conveniently considered in a later section after the principles underlying the use of galvanometers and the details of construction of typical instruments have been described and explained.

## II.—ELECTRIC CURRENT.

**Voltmeter Measurement.**—The measurement of the magnitude of an electric current can be made by means of a voltmeter, provided the current be perfectly steady or liable only to such fluctuations as may be disregarded for the particular purpose in view, in which case the *mean* value of the current can be measured. As we have already explained (page 180), the current is the quantity per second passing any cross-section of the circuit, and the two are therefore connected by the relation :

$$\text{Current} = \frac{\text{quantity}}{\text{time}},$$

or, giving names to the units,

$$\text{Current in amperes} = \frac{\text{quantity in coulombs}}{\text{time in seconds}}.$$

If, therefore, the quantity in coulombs is measured by the methods just described and a note made of the exact time taken to deposit the metal on the kathode, the mean value of the current can be easily calculated.

Thus, suppose a steady current is found to deposit one pound of copper in one hour, then, since a pound is equal to 453.6 grammes, the quantity of electricity is

$$\frac{453.6}{.000326} = 1,391,000 \text{ coulombs (nearly).}$$



But since there are 3,600 seconds in an hour, the value of the current must be

$$\frac{1,391,000}{3,600} = 386 \text{ amperes (nearly).}$$

The objection to this method of measurement is that it is indirect and does not give any indication of the magnitude of the current whilst it is flowing. It is only when the necessary washings and weighings have been completed that the value of the current can be ascertained. It further follows that the method gives no indication as to whether the current has or has not changed in value whilst the electrolysis was in progress.

We thus see that the *chemical* effect is not of much use for the measurement of the current strength except for standardising purposes. The

*thermal* effect is still less available, for it also is cumulative, and the accurate measurement of quantities of heat is a difficult operation. The thermal effect can, however, be used indirectly, as we shall see later.

On the other hand, the *magnetic* effect is eminently suitable for indicating and

measuring the value of the current from instant to instant, provided the fluctuations are not very rapid, though even for moderately rapid fluctuations the difficulties of following the variations have been ingeniously overcome in modern oscillographs.

**Galvanoscopes and Galvanometers.**—These names are given to the instruments which indicate the existence of, or measure the magnitude of, a current *by means of its magnetic effect*. When the direction and approximate strength of a current only are required, very simple pieces of apparatus, known under the name of *galvanoscopes*, are used. To estimate roughly the strength of a current, the simple instrument shown in Fig. 309 is sometimes used; it consists of a wooden frame which carries a few turns of a thick wire, and is sometimes called a multiplier. The frame encloses a pivoted magnetic needle which can be deflected by the current, the deflection being roughly read off on the graduated card below.

A more sensitive instrument is the vertical galvanoscope (Fig. 310). Here two magnets *ns* and *s'n'* are placed parallel to each other, so that the north pole of one is opposite the south pole of the other. Such an arrangement of the needles is known as *astatic*. The needles are rigidly

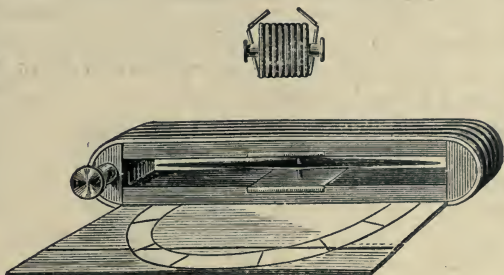

Fig. 309.—A Multiplier.

attached to a horizontal axis which is a little above their centre of gravity, so that they stand vertically when no current is passing through the coils. When the current passes the needles are deflected towards the horizontal, but gravity causes them to set in some intermediate position depending on the strength of the current.

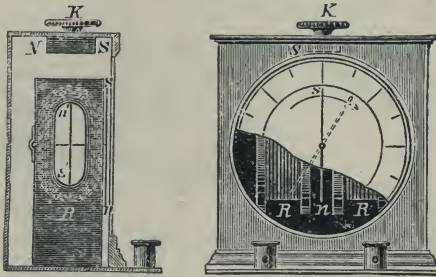

Fig. 310.—The Vertical Galvanoscope.

It usually has two coils which may be connected, so that the same current goes round both in the same direction or in different directions, or they may be used separately. The frame for the coils and the astatic pair of needles are shown separately drawn. The frame

with the coils is fastened upon a horizontal metal disc, which moves upon the bottom plate, and is maintained in a horizontal position by means of three levelling screws. The screw *s* is for clamping the disc with the coils in position when the zero of the scale is brought into the magnetic meridian. A usual arrangement is to wind one of the coils with about 100 turns and the other with about 10,000. The four binding screws *p* to *o* are in connection with the ends of the two coils. The needles are hung from the metal support *EFG*, and can be adjusted vertically by the screw *k*, which is for the purpose of raising or lowering the needles. The number of turns which should be wound upon the coils of a galvanometer of this type depends entirely upon the purpose

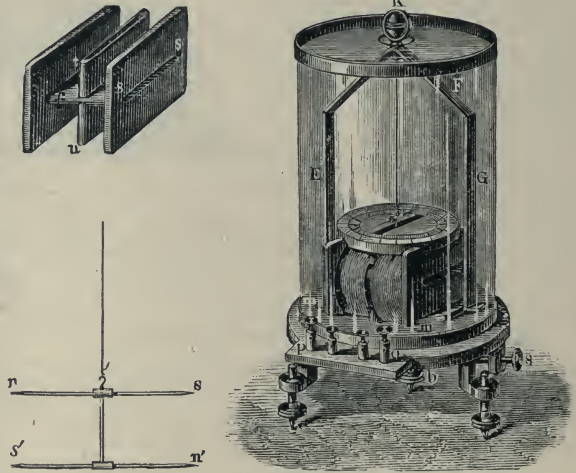

Fig. 311.—The Astatic Galvanometer.

The needles are hung from the metal support *EFG*, and can be adjusted vertically by the screw *k*, which is for the purpose of raising or lowering the needles. The number of turns which should be wound upon the coils of a galvanometer of this type depends entirely upon the purpose

for which it is to be used. When used in a circuit of small resistance, fewer turns of wire will suffice, whilst when used with great resistance a coil of many turns has to be used.

In this instrument, which is typical of a numerously represented class, it will be noticed that the coils form a solenoid of many layers and turns of wire, and that when a current is passed through this wire a magnetic field will be set up in the core of the solenoid proportional to the ampere-turns (*see* page 281). Since one coil has about 100 times the number of turns on the other, a certain current in this coil will produce the same strength of magnetic field as a current 100 times as great in the other coil. The range is therefore considerable. The lower needle  $n' s'$  of the astatic couple is placed in the core  $s s$  of the solenoid, and is acted upon by the magnetic field according to laws already explained. The upper or reversed needle  $n s$  is acted on by the return field outside the solenoid, and since both the field and the needle are reversed, the direction in which this needle tends to rotate will be the same as that of the lower needle. Both needles are therefore rotated by the current in the same direction. But the needles are also under the influence of the horizontal component (*see* page 38) of the earth's magnetic field, which tends to hold them in the zero position, that is, in the magnetic meridian. The actual position taken up will be that in which the turning effects of the two fields are balanced, and in this position the needle will come to rest. The deflection so obtained will obviously increase with increase of current, but it would be wrong to assume that the deflections are proportional to the current. This should be carefully borne in mind in using such an instrument. It may be noted that the restoring effect of the earth's field is diminished on account of the reversal of one of the magnetic needles, although this reversal increases the deflecting effect due to the current's field. Both results, therefore, tend in the direction of greater sensitiveness.

The astatic galvanometer described was invented by Nobili, and was used by him in his classical researches on radiant heat. It is sufficiently sensitive for a wide range of electrical experiments, some of the more common and fundamental of which we shall describe presently. We postpone to a later section the description of the more sensitive and more modern galvanometers.

**Large Current Galvanometers.**—The astatic galvanometer is only suitable for the direct measurement of small currents, such as were generally used before the development of heavy electrical engineering in the last thirty years. This development has, however, created a widespread demand for instruments of precision, capable of measuring accurately the much larger currents and voltages than were met with in telegraphy or any of the early applications of electricity to the service of man. Moreover, the varied and special conditions under which the instruments have to be used have reacted on the designs, with the result



that there is available to-day a great variety of instruments for all kinds of electrical measurements, and the list is being continually added to. In this part of the book we shall, however, only deal with the principles involved as illustrated by typical instruments of historical interest, leaving to the later section the description of some of the leading instruments in use at the present time.

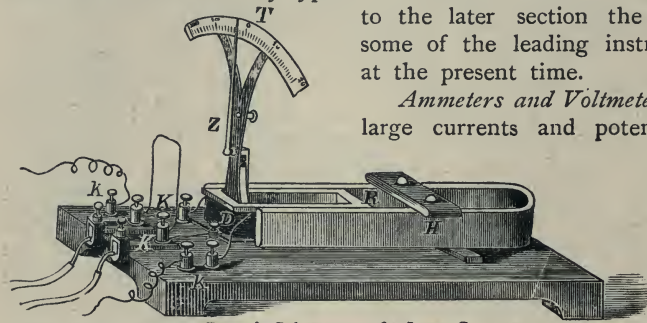

Fig. 312.—Deprez's Galvanometer for Large Currents.

*Ammeters and Voltmeters.*—When first large currents and potential differences began to come into common use, the want of convenient names to describe the instruments designed to

measure them soon made itself felt. Such instruments are essentially galvanometers, but this latter term is not sufficiently distinctive. Professors Ayrton and Perry, therefore, proposed the term "Ammeter" (a contraction of the word ampere meter) for the instruments that measure heavy currents, and "Voltmeter" for those which measure the corresponding pressures. These terms are now very generally used

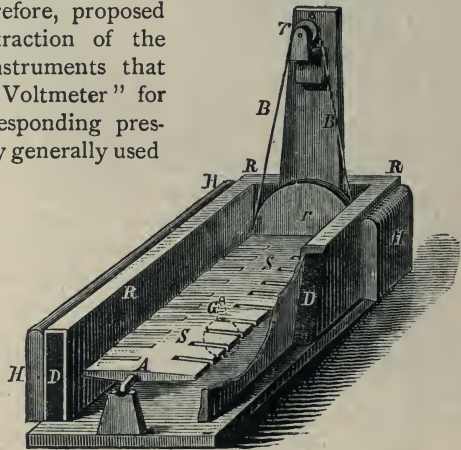

Fig. 313.—Deprez's Galvanometer.

The special feature which distinguishes such instruments from the more sensitive galvanometers, and the feature which so profoundly modifies the design as to alter entirely, in most cases, the main details of construction, is the fact that, with the larger currents available, the mechanical forces called into play, though still small, are such as can be more readily

gauged and measured than can the almost infinitesimal forces acting in the more sensitive instruments. This was soon realised by inventors, and its influence is shown even in the early instruments.

The earliest one on record is Deprez's galvanometer for large currents, represented in Figs. 312 and 313, in which H is a steel horse-shoe magnet; R a wooden frame, which carries a copper band, and several windings of wire D. One set of binding screws K is in connection with the copper

band, and the other binding screws *K*, are in connection with the coil of finer wire. Inside the frame is a soft iron plate *s*, which has ten incisions on each side, and moves round a horizontal axis upon two knife edges. One of these knife edges is seen at *A* in Fig. 313. The parts of *s* become magnetised by induction of the permanent magnet, and whenever an electrical current flows round them they are deflected from their position of rest by the vertical field set up by the current. When the galvanometer has no current the little weight *G* helps to bring the iron plate back into its first position. The motion of the plate is indicated by the pointer *Z*, which moves along the scale *r*. To make it more convenient for use, the instrument was usually gauged in amperes; that is to say, it was determined by experiments in what proportion the divisions on the scale stand to an ampere.

The earliest form of the galvanometer or ammeter of Ayrton and Perry

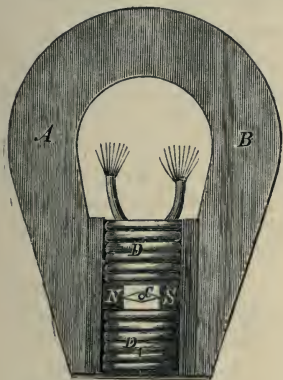

Fig. 314.—Ayrton and Perry's Ammeter.

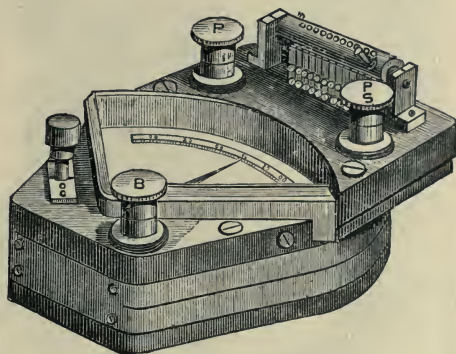

Fig. 315.—Ayrton and Perry's Ammeter.

also gave direct readings in ampères. A very light magnetic needle *c* (Fig. 314) could move freely in the magnetic field formed by the pole-pieces *N* and *s* of the magnet *A. B.* The two coils *D D* consisted each of ten wires, and were so arranged that each deflection of the needle was directly proportional to the strength of the current. The wires were in connection with a cylinder having contact springs (Fig. 315). By simply turning this cylinder, the ten separate circuits of the instrument could be arranged either in series or parallel. The instrument was very sensitive, and was also easily graduated at any time. In both Deprez's and Ayrton and Perry's instruments the influence of the earth's magnetism is reduced to a minimum by having the needle in a strong independent magnetic field. Ayrton and Perry constructed a voltmeter on a similar principle to that of their ammeter. The difference was that the voltmeter\* had coils of 400 ohms resistance, and measured the

\* The method of using a galvanometer as a voltmeter will be explained later. (See page 372.)

difference of potentials between two points in volts, whereas in the ammeter the resistance in series was about 0.3 ohm and in parallel 0.005, the latter being more than one hundredth of the former, in consequence of the resistance of the small leading wires inside the instrument. The ammeter was calibrated in series and generally used in parallel circuit, whereas the voltmeter was calibrated in parallel circuit and used generally in series, and then indicated from 1 volt per degree in some instruments to 5 volts per degree in others, the total deflection of 45°

in the latter case being obtained with 225 volts.

But just as the ammeter could be conveniently used in series, when testing the comparatively small currents passing through a single incandescent lamp, so the voltmeter could be used in parallel circuit for testing electro-motive forces of two or three volts, such as, for example, the electro-motive force of one or two Faure's accumulators. To calibrate the voltmeter, the commutator was turned to *parallel*, so that the resistance of the instrument was 4 ohms, and a current was sent through the instrument by a cell of known electro-motive force  $E$ ,

but of unknown resistance, producing, say, a deflection of  $D_1$ ; the plug attached to the instrument was now taken out, which had the effect of adding a resistance of 4 ohms to the circuit, and a second deflection  $D_2$  was obtained.

From this it can easily be proved that a potential difference of  $10 \times \frac{D_1 - D_2}{D_1 D_2} E$  volts between the terminals of instrument would produce a deflection of 10° when the commutator was set to parallel, or 1° when set to series.

The instrument just described was afterwards improved, but was eventually replaced, for many purposes, by an entirely different type designed by the same inventors, known either as the "Solenoid Ammeter" or the "Magnifying Spring Ammeter." It is shown in Fig. 316, whilst

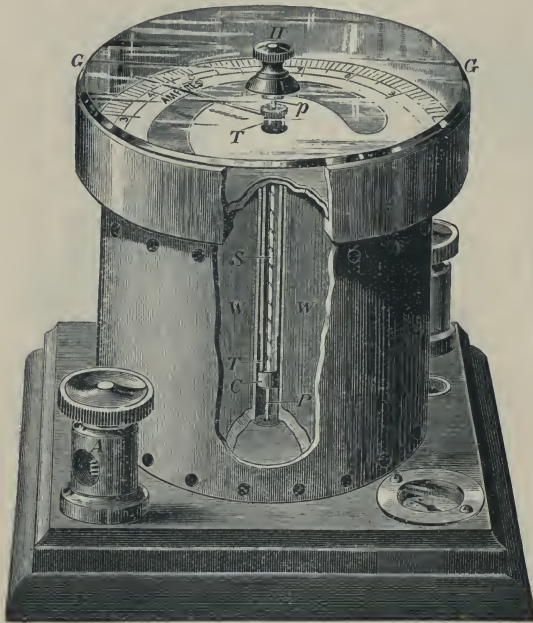

Fig. 316.—Ayerton and Perry's "Magnifying Spring" Ammeter.



the spiral spring used in it is shown separately in Fig. 317. This form of spring has the property, first pointed out by Professors Ayrton and Perry, that if one end be fixed and the other be free to turn, for a small extension of the spring there is a comparatively large proportional rotation of the free end. It is, therefore, well adapted for magnifying a small lateral extension into a large rotational deflection.

In Fig. 316 such a spring  $s$  is attached at its upper end to the milled head  $H$ , and hangs freely down. At its lower end is attached a cap  $c$  which supports a soft iron tube  $\tau \tau$ , the upper end of which carries an aluminium pointer which moves over a graduated scale;  $\tau \tau$  is quite free to rotate with the lower end of the spring. The current-carrying conductor is wound in the space  $w w$  outside the tube, in the form of a solenoid, of which the tube and spring form the vertical axis. On a current passing through this solenoid the soft-iron tube is sucked downwards, thus stretching the spiral spring and causing its lower end to rotate. The amount of rotation is indicated by the pointer on the dial. The scale below the pointer can, therefore, be marked with either the amperes or the volts corresponding to the various deflections of the pointer, according as the instrument has been wound for an ammeter or a voltmeter.

A type of electro-magnetic ammeter or voltmeter which is very widely used is that in which the controlling force counterbalancing the action of the current is due to gravity. An early and good form of such an instrument, designed by Messrs. Nalder



Fig. 318.—Nalder's Gravity Ammeter.

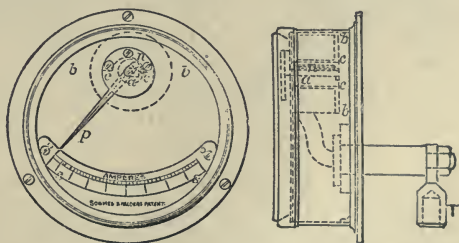

Fig. 319.—Details of Nalder's Gravity Ammeter.

Brothers and Co., is shown in Fig. 318, whilst the details are depicted in Fig. 319. A light pointer  $p$  pivoted on an axle  $a$  carries at its shorter end a small bundle  $n$  of soft-iron wires. These wires project backwards into the hollow core  $c c$  of the coil of the solenoid  $b b$ . When a current



Fig. 317.—Spring of Ammeter.

passes through the solenoid a magnetic field is set up in the core-space  $cc$ , which is stronger at the edges than along the axis. Now a piece of soft iron in a non-uniform magnetic field always tends to move towards the strongest part of the field. Neither the axle  $a$  nor the wires  $n$  are at the axis of the solenoid, and they are so arranged that when the magnetic field is set up the wires  $n$  are free to move towards a stronger part of the field in such a way that the pointer  $p$  deflects to the right. This action is assisted by a small bundle of iron wires fixed close to the position of rest of  $m$  so as to repel  $n$  when magnetised by the field of the solenoid. The pivoted system is so balanced that when the instrument is set up in a vertical position, with no current passing through it, the pointer  $p$  stands opposite the zero of the scale. When the current passes  $p$  is displaced from its balanced position, to which gravity tends to restore it. Under these conflicting influences the pointer takes up a position which depends on the current in the solenoid  $bb$ , and the mark on the scale indicates either the amperes passing through the coil in the case of an ammeter, or the volts causing the current in the case of a voltmeter.

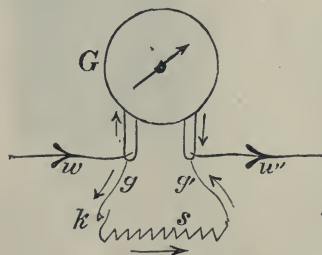

Fig. 320.—Shunting a Galvanometer.

Many other kinds of instruments have been designed in which various forms of spiral springs, or of permanent or electro-magnets, have been used to counterbalance the effect of the current. Some of these now in common use we propose to describe in the later section, where we shall also allude

to one or two indirect methods of measuring large currents which are convenient in heavy engineering work.

**Shunting Galvanometers.**—In measuring small currents it frequently happens that a galvanometer is much too sensitive for a particular experiment; in other words, its sensitiveness is such that if the whole current to be measured were passed through it the moving part would be driven violently against the stops, and the instrument would be damaged. In this case the principles explained at page 187 are taken advantage of, and only a fraction of the current is passed through the galvanometer  $G$ , the remainder being *shunted* past it along a *shunt* or by-path  $s$  placed across the terminals of the instrument, as shown in Fig. 320.

If necessary, the ratio of the total current in  $w$  to the current passed through the galvanometer  $G$  and measured can easily be found, provided we know the relative resistances of  $G$  and  $s$ . Thus, if the resistance of  $s$  be  $\frac{1}{n}$ th the resistance of  $G$ , the current through  $s$  will be  $n$  times the current through  $G$ , and therefore the current in  $w$  (that is, the current in the main circuit) will be  $n + 1$  times the current in  $G$ .

The path  $s$  is said to be a "shunt" on, or in "parallel" with, the path  $g$ .

**Cross Shunts.**—In electrical work more complicated arrangements often become necessary both for practical and experimental purposes. To understand these arrangements more clearly, we shall again have recourse to the analogy of the flow of water in pipes already used in pages 180 to 189. Let Figs. 321, 322, and 323 represent three different systems of pipes. In each of the three figures water flows from  $a$  in the directions of the arrows, by two pipes through which it can flow to  $c$ ;

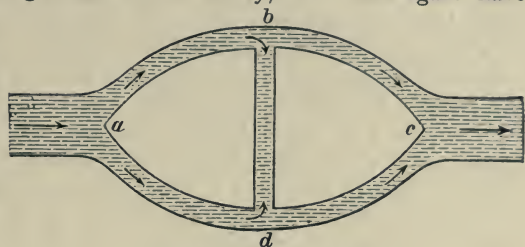

Fig. 321.—Cross Water Channel.

the greatest amount of water will enter into the branch pipe with the greatest cross-section because it offers the least resistance. The quantity of water flowing at  $c$  into the outlet pipe will be equal to the quantity of water entering at  $a$ , and the total amount of water flowing through  $abc$  and  $adc$  will be equal to the amount of water in the undivided pipe. In Fig. 321 the water flows in the direction of the great arrow to  $a$ , where it finds two pipes exactly like each

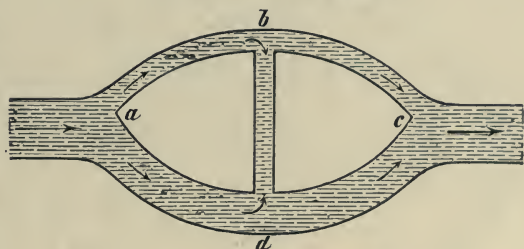

Fig. 322.—Cross Water Channel.

other,  $abc$ ,  $adc$ . The water will be equally divided here, and through each pipe half of the original amount will flow. The pipe  $bd$  connects  $abc$  with  $adc$ , and we have now to enquire how the water will flow in  $bd$ . The water flowing along  $ab$  and  $ad$  finds at  $b$  and at  $d$  the same conditions as to pressure. The pressures from  $b$  to  $d$  and from  $d$  to  $b$  oppose each other, and thus remain in equilibrium. The water in  $bd$  remains then at rest, because the resistances in  $abc$  and  $adc$  are divided at the points  $b$  and  $d$  in the same proportion. For the same reason the

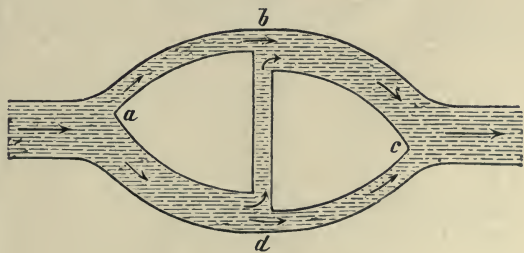

Fig. 323.—Cross Water Channel.



water in  $ba$  (Fig. 322) will remain at rest, although the pipes  $abc$  and  $adc$  are here different from those of the previous figure, and offer a different resistance. The ratio of the resistances of the parts of pipes to each other, however, remains the same as in the former case. The conditions will, however, be altered in the arrangement shown in Fig. 323. Here the water divides at  $a$  into two unequal currents, the larger of which,  $ad$ , arrives at  $d$ , where it meets a much smaller pipe, offering a greater resistance. The pressure will force water along the cross pipe  $db$  beyond  $b$  in the direction from  $d$  to  $b$ . This motion will be favoured by the pipe  $bc$ , which, being much broader, facilitates the further flow. Hence such an arrangement as that shown in Fig. 323 will cause the water to flow in the cross channel in the direction from  $d$  to  $b$ .

Fig. 324 represents an arrangement of an electric circuit similar to that of the system of pipes just now explained. The current, leaving the battery, divides at  $a$  into two branches; one branch flows through  $ab$ , the other through  $ad$ ; at  $b$  and  $d$  the tendency for a current to flow through  $bd$  in either direction will depend upon whether the electric pressure at  $b$  or at  $d$  is the greater. The two opposite tendencies to flow along  $bd$  will either weaken or entirely neutralise each other. Whether there be a current in  $bd$  or not, there will be currents in  $bc$  and  $dc$ , which, meeting at  $c$ , will then flow back to the battery.

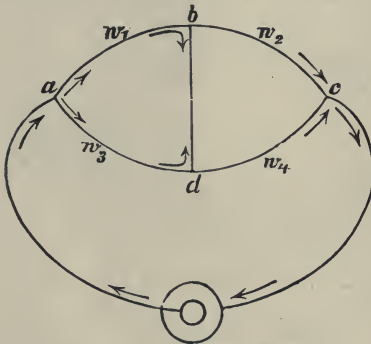

Fig. 324.—Cross Shunt (Electric).

To complete the analogy we wish to trace, let us suppose the flow of water to be produced by a difference of level between the points  $a$  and  $c$  (Fig. 321). Suppose the stream to be flowing by two channels  $abc$ ,  $adc$ , from a higher level at  $a$  (where the height above a certain initial level is  $v_1$ ) to a lower level  $v_2$  at  $c$ . For any point  $b$  in the first channel there is a point  $d$  in the second, which is at the same level  $v$ . If these two points are joined by a channel  $bd$ , there will be no flow along  $bd$ , because the ends are at the same level  $v$ . Let us now follow the analogous arrangement of a divided electrical current (Fig. 324). If the potentials at  $a$  and  $c$  be  $v_1$ ,  $v_2$ , and that at  $b$  be  $v$ , then there will always be a point  $d$  in  $adc$ , having the potential  $v$ , and if this point be joined to  $b$  by a wire  $bd$  in which there is a galvanometer, there will be no indication of current in  $bd$ . Now, what must be the relations between the resistances  $ab$ ,  $bc$ ,  $ad$ ,  $dc$ , that there may be no current in  $bd$ ? By an extension of Ohm's law (page 182), applicable either to the hydraulic or the electric case,

the current in any part =  $\frac{\text{fall of potential or level in that part}}{\text{resistance of that part}};$

$$\left. \begin{aligned} \text{hence current in } a b &= \frac{v_1 - v}{\text{resistance } a b} \\ \text{current in } b c &= \frac{v - v_2}{\text{resistance } b c} \end{aligned} \right\}$$

$$\left. \begin{aligned} \text{current in } a d &= \frac{v_1 - v}{\text{resistance } a d} \\ \text{current in } d c &= \frac{v - v_2}{\text{resistance } d c} \end{aligned} \right\}$$

But when there is no current in  $b d$ , the currents in  $a b$  and  $b c$  are the same, and so are those in  $a d$ ,  $d c$ ; hence from the first two equations:—

$$\frac{v_1 - v}{\text{resistance } a b} = \frac{v - v_2}{\text{resistance } b c};$$

or,

$$\frac{v_1 - v}{v - v_2} = \frac{\text{resistance } a b}{\text{resistance } b c}.$$

Similarly from the last two—

$$\frac{v_1 - v}{\text{resistance } a d} = \frac{v - v_2}{\text{resistance } d c};$$

or,

$$\frac{v_1 - v}{v - v_2} = \frac{\text{resistance } a d}{\text{resistance } d c}.$$

Therefore

$$\frac{\text{resistance } a b}{\text{resistance } b c} = \frac{\text{resistance } a d}{\text{resistance } d c}.$$

If the resistances in one branch are equal, those in the other branch must also be equal.

III.—ELECTRIC RESISTANCE.

The principles laid down here give a most convenient method for measuring resistances. The instrument or arrangement by which it is applied was first used by Professor Wheatstone, and is called *Wheatstone's Bridge*. Like all the so-called *nul* methods, which consist in reducing to zero the current in a particular circuit, it admits of great accuracy. The simplest mode of applying it is as follows: Let M (Fig. 325)



Fig. 325.—Principle of Wheatstone's Bridge.

be an unknown resistance, and N a measured resistance which may be adjusted to any required value. Let P and Q be two other equal resistances. Arrange M and N in one branch, and P and Q in the other branch of a divided circuit. Connect a galvanometer at G with the junction of M and N on one side, and the junction of P and Q on the other. Adjust N until there is no current through G, then  $M = N$ . Or if P and Q be not equal in resistance we still have by the equation proved above:—

$$\frac{M}{N} = \frac{P}{Q},$$

whence

$$M = N \times \frac{P}{Q}.$$

The Wheatstone bridge is one of the most important pieces of apparatus used in electrical work. Various forms of it have been devised for general and special experiments; some of these we shall describe later on. All the methods, however, require at least one *known* resistance (the resistance  $N$  in the above equations), in terms of which the value of the unknown resistance is obtained. We shall, therefore, now refer to the subject of such standards of resistance.

**Units of Resistance.**—In the early days of electrical measurements the necessity for universally recognised units was severely felt, and in no direction more so than in that of the unit of resistance. In the absence of a common unit each experimenter had to take whatever was most convenient at the moment, such as the resistance of a particular piece of wire in his laboratory. Jacobi suggested the use, as a unit of resistance, of a copper wire one metre in length and one square millimetre in cross sectional area. But this unit proved unsatisfactory, because the resistance of copper is considerably altered by even slight impurities, and in Jacobi's time methods of producing electrically pure copper in large quantities had not been discovered. Siemens, therefore, proposed the mercury unit, usually known as the Siemens unit, and consisting of a column of mercury one metre in length and one square millimetre in cross section, at a temperature of  $0^{\circ}\text{C}$ . The advantages of using mercury are that it can be readily obtained in a state of purity, and being a liquid at  $0^{\circ}\text{C}$ . its physical condition at that temperature is perfectly definite.

Not the least of the services which the Committee of the British Association rendered to electrical science was the initiation and carrying out of a series of researches on the electrical resistances of various conductors under various conditions, and the determination of the concrete resistance which should most nearly represent the theoretical resistance known as an ohm. In these researches most of the prominent men of science, without distinction of nationality, ultimately joined. The results obtained were accepted internationally, and were officially adopted by most civilised governments. The final conclusion with regard to the **ohm** is that it is most nearly represented by *the resistance at  $0^{\circ}\text{C}$ . of a column of mercury 106 centimetres long and of uniform cross section throughout, and weighing 14.4521 grammes.* The weight named is that of a column of mercury of the specified length and one square millimetre in cross section, but for certain practical reasons it was thought better to specify the weight rather than the cross section.

The standard ohm is seldom used in the form defined above, and when so used it is chiefly for the purpose of ascertaining the exact



value of the resistance of some conductor of more convenient material and shape. Even the wire copies of the ohm and its sub-multiples and multiples usually known as *standard coils* are, as a rule, only used when high accuracy of measurement is required. For this reason all the details connected with them have been carefully considered by scientific men, many of whom have made suggestions for improving the construction of such coils. We shall describe some of the best known forms later, but we pass on now to describe some of the less accurate forms of coils of known resistances which are widely used for work where very high accuracy is neither required nor sought. Such forms of resistance coils can usually be rapidly adjusted to various approximately known values, and are used as standards for ordinary work in the same way that ordinary approximate weighings, the weights of accurately known value and the sensitive balances only being used when high accuracy is required.

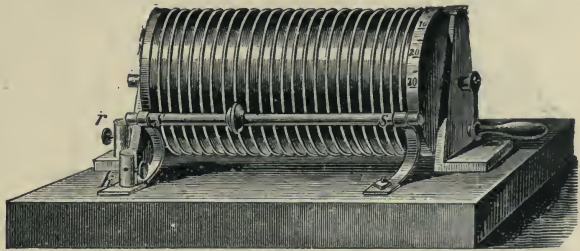

Fig. 326.—The Rheostat.



Fig. 327.—Poggendorff Rheochord.

**Adjustable Resistances.**—For ordinary laboratory work wide ranges of resistances are required, and it is often necessary and always convenient that it should be possible to increase or diminish the resistance in circuit *without breaking the circuit*. There are three principal ways of doing this: (*a*) by a sliding contact moving over the resistance wire or wires; (*b*) by withdrawing or inserting plugs between brass blocks, to which the ends of coils of known resistance are attached; (*c*) by contact pieces sliding over the surfaces of plugs to which also the ends of coils of known resistance are attached.

The first method (*a*) is used in the two pieces of apparatus shown in Figs. 326 and 327. The instrument in Fig. 326 is known as a Rheostat. A wire having a known resistance per unit of length is wound spirally on a cylinder of wood or ebonite. This cylinder can be turned by

a handle. One end of the wire is permanently connected to the binding screw  $r$ , and the other is insulated. The thick rod  $s s$ , connected to the binding screw  $k$ , carries a sliding terminal which presses, by means of a spring, against the wire; the latter acts like a screw when the handle is turned, and moves this terminal along the rod. Any number of turns and fraction of a turn of the wire can thus be brought into the circuit, the number of turns being read off on a scale on the rod, and the fractions of a turn on the divided flange at the right-hand end of the cylinder. The rheostat shown here is easily injured, and has many faults; it is therefore not used now so much as formerly. Poggendorff's rheochord, represented in Fig. 327, is somewhat more reliable. The two platinum wires  $a$  and  $b$  are fastened at one end to the small copper blocks  $d$  and  $c$ ; at the other end  $e f$  the wires are fastened to silken cords, which run over the rollers  $g$ , and carry

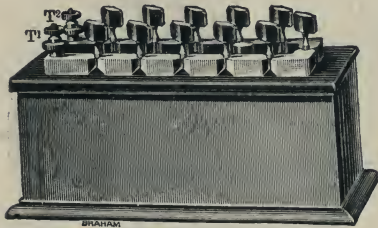

Fig. 328.—Plug Resistance Box.

weights for the purpose of giving the platinum wires a uniform stretch.  $\kappa$  is a sheet-iron box filled with mercury, which has the sides through which the wires pass made of glass. The instrument is inserted in the circuit by means of the screws  $d c$ . The current enters through one of the screws, passes through the wire up to the box, through the mercury to the next wire, and leaves the apparatus through the

other screw. It is easily seen that by moving the box along the two platinum wires different lengths of wire can be inserted; in order to measure these, the instrument has a graduated scale. It is, however, difficult to obtain the wires perfectly uniform through their whole length, and therefore the actual value of the resistance inserted or removed is not very accurately known without troublesome calculations.

**Resistance Boxes.**—The second method, ( $b$ ), of altering the resistance without breaking the circuit, is by means of resistance boxes, similar to that shown in Fig. 328. In these the range of resistance available can be made much greater than is possible with a single wire. The general method of connection is shown in Fig. 329. The ends of a coil of known resistance are connected with brass pieces  $C^1, C^2$ , which are divided from each other by a small space, bounded by slightly conical surfaces. If now the current enters one of these brass pieces it cannot flow to the next before it has gone through the coil between them; but the current can pass directly from one brass piece to the other when a plug  $P^1$  is inserted. In the absence of the plug the current, which reaches  $C^1$  in Fig. 329, would have to flow through the resistance coils  $W^1$  before it could reach the

second piece of brass  $C^2$ . In the series of such resistance coils of graduated resistance is arranged. The resistance of each coil is exactly determined, and the coils are arranged in a convenient order, the resistance of each coil being marked on the ebonite top of the box, close to the hole which the coil bridges. It is found to be convenient to use values which can be easily added together, and with which any required resistance within the range of the box can be quickly made up. The following values of successive coils are very frequently used:—

1st Row	...	1	2	2	5	10	10	20	50
2nd Row	...	5,000	2,000	1,000	1,000	500	200	100	100

With an arrangement like this, any whole number from 1 to 10,000 ohms can be obtained. For fractions of a unit, resistance coils of 0.1, 0.2, 0.2, and 0.5 ohms are added, or the unit may be subdivided by making it one branch of a Wheatstone's bridge. When the resistance box (Fig. 328) is used, care ought to be taken that all the metal parts are bright, especially the bores, and that the plug is firmly placed into the hole with a slight screwing motion.

The third method,  $c$ , is illustrated in Fig. 330. Here again the actual resistances are embodied in coils of wire within the box, the ends of the coils being brought up to the brass blocks on the top in a manner

similar to that shown in Fig. 329. The pattern is known as the "dial" pattern, and in each dial there are eleven brass blocks arranged round the circumference of a circle, and numbered 0, 1, 2, . . . . 9, 10. A sliding contact at the end of a radial arm passes over these blocks, and between each two blocks in the dial a resistance coil is connected up, the resistances in any one dial being all equal to one another. Thus in Fig. 330 the resistances in dial A are all single ohms, in dial B they are each equal to 10 ohms, and in dial C to 100 ohms. The connections, and the plan of the top of the box, are given diagrammatically in Fig. 331. If the radial arms be

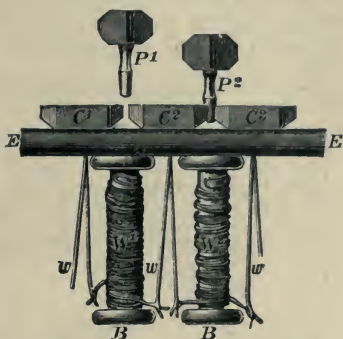

Fig. 329.—Resistance Coil and Plug.



Fig. 330.—Dial Resistance Box.



in the positions shown the current entering at  $T_1$  passes through the box to  $T_2$ , as follows:—From  $T_1$  by a connecting strap to block 0 of dial A, and through the two first coils of dial A to the radial arm  $R_2$ ;

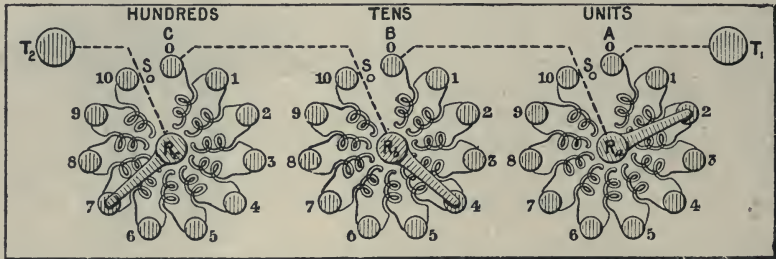

Fig. 331.—Connections of a Dial Resistance Box.

from this radial arm, by another connecting strap, to block 0 of dial B, through the first four coils of dial B to radial arm  $R_2$ ; similarly to block 0 of dial C, seven coils of dial C, and finally to terminal  $T_2$ . The resistance in the box, 742 ohms, through which

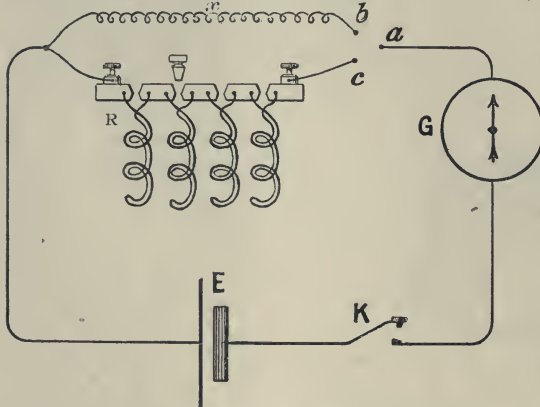

Fig. 332.—Simple Method of Measuring Resistance.

the current passes is read off at once by simply reading in order the numbers opposite the radial arms on the three dials. Additional dials for thousands or fractions of ohms can be added if required. The radial arms are usually made of laminated copper, and should have a good bearing surface, such as can be seen in Fig. 330.

**Simple Measurement of Resistances.—**

We are now in a position to measure approximately the resistance of any wire. We may make the experiment in many ways, one of the simplest being as follows:—A complete circuit (Fig. 332) is made with a constant voltaic cell  $E$ , a galvanometer  $G$ , and the wire  $x$  whose resistance is to be taken. The deflection of the needle is noted, and the wire to be measured removed, and in its stead is placed a rheostat, or resistance box  $R$ . This change may be conveniently made by having three contact points  $a$ ,  $b$ , and  $c$ , as shown. Resistance is now changed until the needle shows the same deflection as before. This resistance will be

equal to the resistance of the wire under examination. This method of determining the resistance (called the method of substitution) has several defects. Between the first and second reading a certain time passes, during which the E. M. F. and internal resistance of the battery may have undergone some change. We may partly eliminate the error by again inserting the resistance to be measured, and taking the mean of two observations.

The method of the Wheatstone bridge is not open to this objection. We have seen that in an arrangement like that represented in Fig. 324 the connecting wire  $b d$  is without a current when the resistances of the remaining four wires stand as follows :

$$\frac{\text{resistance of } a b}{\text{resistance of } b c} = \frac{\text{resistance of } a d}{\text{resistance of } d c}.$$

Fig. 333 shows us how to use this principle and to measure resistances with the bridge. The screws  $a b c d$  are fixed at the corners of a rhombus ; the screws  $e f g h$  in two sides meeting at the point  $d$ .

The wires  $a b$  and  $b c$  are equal to each other, and possess the same resistance ; the wires  $a e, f d, d g,$  and  $h c$  are also equal to each other, and have the same resistance. The galvanometer  $B$  in the connecting wire  $b B d$  will show no current when the resistances of the wires  $a b$  and  $b c$  are to each other as all the resistances between  $a$  and  $d$  are to all resistances between  $d$  and  $c$ .

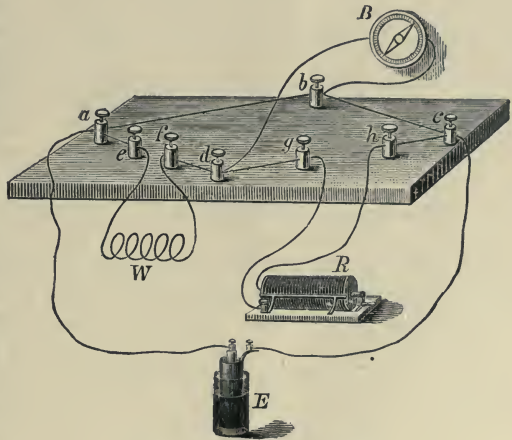

Fig. 333.—Wheatstone's Bridge.

A galvanometer being inserted at  $B$ , the wire under examination  $w$  is inserted between  $e$  and  $f$ , and any rheostat or box of coils  $R$  between  $g$  and  $h$ . When in this circuit the connecting wire  $b b d$  is without current, the following equation must be true :

$$\frac{\text{resistance of } a b}{\text{resistance of } b c} = \frac{\text{total resistance between } a \text{ and } d}{\text{total resistance between } d \text{ and } c}.$$

It follows, therefore, that when the wires  $a b$  and  $b c$  are of the same resistance, and no current passes through  $b b d$ , the sums of the resistances between  $a d$  and  $d c$  must be equal. Finally, in this case, since the wires  $a e, f d, d g,$  and  $h c$  are equal to each other, the resistance of  $w$  must be equal to the resistance between  $g$  and  $h$ .

## IV.—ELECTRICAL PRESSURE.

**Simple Measurement of Electromotive Force.**—The E. M. F. of a galvanic cell may be ascertained by taking the difference of potentials at the two poles by a Kelvin's quadrant electrometer (*see* page 374). But indirect methods of determination are, as a rule, more convenient. We may measure the resistance and current of the cell, and calculate the E. M. F. from these values, by means of Ohm's law. As we require a unit for measuring resistance, we require a unit for measuring E. M. F., and as already explained, the *Volt* is the unit employed, the E. M. F. of a Daniell's cell being nearly equal to 1.12 volts.

The E. M. F.'s of two cells—a Grove's and a Daniell's, for instance—may easily be compared by the following method, due to Poggendorff, and usually known as the *Potentiometer method*. Let  $E_1$  and  $E_2$  (Fig. 334) be the cells to be compared. Stretch over a scale a German silver or platinum wire  $ab$ , of any convenient length. Take a battery the E. M. F. of which is known

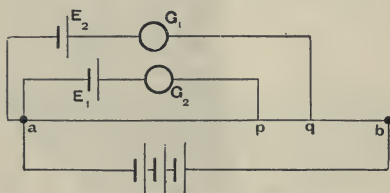

Fig. 334.—Diagram of a Potentiometer.

to be greater than either  $E_1$  or  $E_2$ , and join it up with  $ab$ , the zinc being towards  $a$ . Join  $E_1$  and  $E_2$  with galvanometers  $G_1$  and  $G_2$  in their circuits, so that the wires from the zincs come to  $a$ , and the positive wires to movable points  $p$  and  $q$ . Move  $p$  along  $ab$  until there is no deflection of  $G_2$ , and then do the same with  $q$  till there is no deflection of  $G_1$ . Then  $E_1$  is equal and opposite to the P. D. between  $p$  and  $a$ , and  $E_2$  to the P. D. between  $q$  and  $a$ . But the fall of potential along  $ba$  varies as the resistance (by Ohm's law), and therefore as the length, if the stretched wire be perfectly uniform in material and cross-section throughout its length. Hence  $E_1 : E_2 ::$  the length  $ap : \text{the length } ab$ .

The E. M. F. of a cell is measured by the difference of potentials at the poles of the unclosed cell. If, therefore, we have a cell whose difference of potentials is = 1 volt, we may consider the E. M. F. of this cell to be the unit of E. M. F., and call it 1 volt. If we compare the E. M. F. of a Daniell's cell with the volt, we find that 1 Daniell, if in good condition, has an E. M. F. of 1.12 volts. Bunsen's cell has an E. M. F. of 1.95 volts.

The potentiometer method has the great advantage that the E. M. F. is measured when the cell is sending no current. It is only in such a case that the pressure on the terminals is equal to the full E. M. F. of the cell, and that the E. M. F. itself is not being subjected to changes due to polarisation caused by the current. The method requires that the E. M. F. of one of the cells shall be accurately known, and with this object in view much attention has been devoted to the subject of "*Standard*



Cells," as they are called, and the conditions under which their E. M. F.'s may be relied upon as standards of pressure. We describe some of the usual patterns on pages 364 to 370.

The comparison of the E. M. F.'s of two cells can be approximately made by simple applications of Ohm's law. Thus:—with a box of adjustable resistances and a galvanoscope form a simple circuit (Fig. 335) consisting

of one of the cells  $E_1$ , the resistance box  $R$ , and the galvanoscope  $G$ , and alter the resistance in the box until the galvanoscope gives a convenient deflection. Now change the cell to  $E_2$  and again alter resistance until the *same deflection* as before is obtained. Then in each case the *same current* is generated, and therefore the E. M. F.'s will be proportional to the resistances of the circuits round which the current passes. In

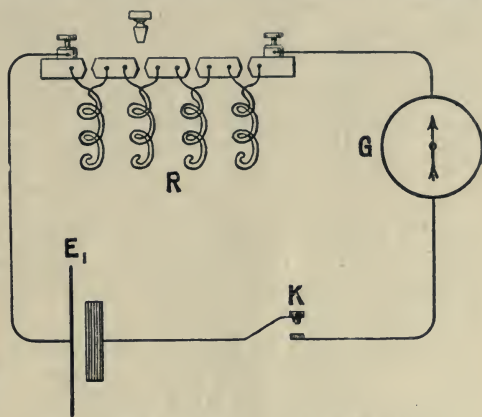

Fig. 335.—Simple Method of Comparing E. M. F.'s.

calculating this resistance in each case it must be remembered that it consists of the resistances of the battery and the galvanoscope as well as the resistance of the coils in the box.

The experiment may be varied by using a galvanometer of known law instead of a galvanoscope, and allowing the currents to be different in the two cases. The *ratio* of the two currents will be known from the deflections and the law of the galvanometer, and hence the ratio of the E. M. F.'s required to send these currents through known resistances can be calculated by Ohm's law.

Another method is to keep the resistance of the circuit unchanged, to use both cells and to have a galvanometer in circuit. The cells  $E_1$  and  $E_2$  are first joined up (Fig. 336) to *assist* one another, and the current ( $C_1$ ) measured by the galvanometer  $G$  in this case is proportional to the sum ( $E_1 + E_2$ ) of their E. M. F.'s. They are then joined up (Fig. 337) to *oppose* one another and give a current ( $C_2$ ) proportional to the difference ( $E_1 - E_2$ ) of the E. M. F.'s. We therefore have

$$\frac{E_1 + E_2}{E_1 - E_2} = \frac{C_1}{C_2}$$

whence

$$\frac{E_1}{E_2} = \frac{C_1 + C_2}{C_1 - C_2}$$

The three last methods are open to the objection that in each of them the cells are required to send currents, and therefore their E. M. F.'s

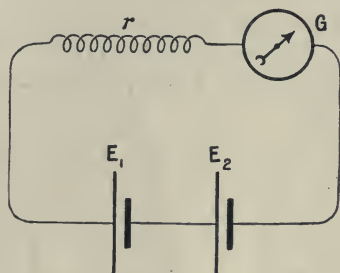

Fig. 336.

Comparisons of Electromotive Forces.

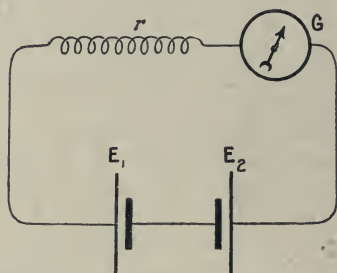

Fig. 337.

may be changed by polarisation during the experiments. Two of the experiments also require that the resistances of the cells should either be known or negligible. These methods can, therefore, only be regarded as approximate.

We have next to describe instruments suitable for measuring directly either the whole E. M. F. in a circuit or the electrical pressure or potential difference (P. D.) between any two points, without reference to the full pressure or E. M. F. which may be acting at some other part of the circuit, or which may even be distributed in different parts of the complete circuit.

For the future we shall use the term E. M. F. for any electrical pressure impressed on the circuit by chemical action, thermo-electric action, electro-magnetic induction or any other means. The term P. D. we shall use for the electrical pressure between any two points without reference usually to the method by which such pressure has been produced. In the case of a cell or other current generator having internal resistance, the E. M. F. and the P. D. at the terminals are the same when the generator is on open circuit or sending no current; whenever a current is passing these two pressures are not equal.

In the measurement of E. M. F.'s and P. D.'s the ultimate standard, as now recognised internationally, is embodied in some form of "standard" cell, and therefore we shall devote a short space here to the description of such cells.

**Standard Cells.**—The Board of Trade definition of the standard of electrical pressure is in these words:—

"The Volt, which has the value  $10^8$  in terms of the centimetre, the gramme and the second of time, is the electrical pressure that, if steadily applied to a conductor whose resistance is one ohm, will produce a current of one ampere, and which is represented by  $0.6974 \left(\frac{1000}{1433}\right)$  of the electrical pressure at a temperature of  $15^\circ$  C. between the poles of

the voltaic cell known as Clark's cell, set up in accordance with the specification appended hereto."

It will be noticed that the material standard referred to is a certain voltaic cell, for the construction of which directions are given. These directions are minute and voluminous and we do not propose to produce them verbatim here, but using the words of the specification we may say that "the cell consists of zinc or an amalgam of zinc with mercury in a neutral saturated solution of zinc sulphate and mercurous sulphate in water, prepared with mercurous sulphate in excess."

The specification then proceeds to give minute directions for purifying the materials, making the solutions and paste, and setting up a cell such as is shown in Fig. 338. The cell is contained within a small test-tube about one inch in diameter and two inches deep. The negative element is the pure mercury at the bottom of the test tube, connection with which is obtained by means of the platinum wire, whose end dips into it; this end is sealed through the lower end of a narrow glass tube which protects the rest of the wire as it is brought up through the cell to form the positive terminal. On top of the mercury floats a paste of the consistency of cream, formed by mixing mercurous sulphate ( $\text{Hg}_2\text{SO}_4$ ) to which a little mercury has been added, with a neutral saturated solution of zinc sulphate ( $\text{ZnSO}_4$ ). The positive element is a rod of pure zinc which dips down into the paste as shown, a piece of copper wire being soldered to the upper end to act as the negative terminal. The zinc rod and the tube containing the platinum wire are held in place by a cork, and the whole is sealed up with marine glue.

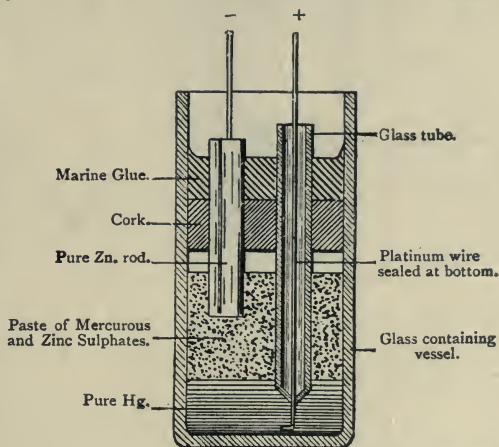

Fig. 338.—Board of Trade, Standard Clark's Cell.

Both before the Clark cell was adopted as the official standard of electrical pressure and since that time its peculiarities have been patiently investigated by many experimenters. Foremost amongst these must be mentioned Lord Rayleigh, whose researches on the subject are classical and who devised the H pattern of cell, which for a long time was regarded as the most reliable, and after an interval has now been readopted. Mr. Fisher, who is one of those who has investigated the subject carefully, prefers to the Board of Trade pattern, for practical use, the form of cell shown in Fig. 339,



constructed by Messrs. Muirhead & Co., the original makers of the Clark cell. In this form the great mass of mercury, which is troublesome in the official pattern if the cell be roughly handled, is replaced by a small quantity

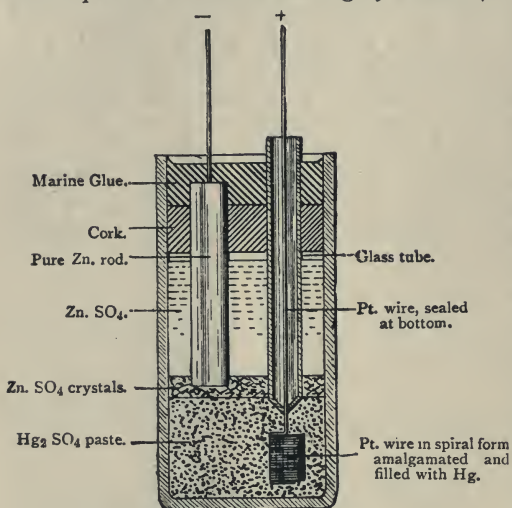

Fig. 339.—Fisher's Modification of Clark's Cell.

of mercury contained in a cylindrical spiral continuation of the platinum wire. This is surrounded by a paste of mercurous sulphate, on the top of which are crystals of zinc sulphate and a saturated solution of zinc sulphate. The zinc rod passes down through the solution and terminates in the zinc sulphate crystals. It is claimed that cells set up according to this pattern give more concordant results than the official cells, and that they stand rough usage, both electrical and mechanical, short of actual breakage, very well.

One of the great disadvantages of the Clark standard cell is its high temperature coefficient, the formula for the variation of its E. M. F. with the temperature usually given being:—

$$E_t = 1.434 [1 - 0.00079 (t - 15)]$$

where  $E_t$  is the E. M. F. at the temperature of  $t^\circ$  C. The standard temperature is  $15^\circ$  C., and the formula means that as the temperature rises the E. M. F. *diminishes* 0.079 per cent. (or about 0.0011 volt) per degree. This is a very serious change, especially when the difficulty of ascertaining the *exact* temperature inside the cell is considered. Moreover, Professor Ayrton has shown that the behaviour of the cell under changes of temperature depends on the way in which the temperature change is made.

Attention has, therefore, been given to the production of cells with a temperature coefficient lower than that of the official standard. Professor Carhart in America used Zn.SO<sub>4</sub> solution saturated at  $0^\circ$  C., and therefore not saturated at  $15^\circ$  C. The E. M. F. at  $15^\circ$  C. was found to be 1.442 volts, and the temperature coefficient 0.00039—or about one-half of that given above. Other advantages are claimed for the Carhart-Clark cell.

Professor Carhart in 1893 and Mr. Hibbert independently in 1896, by using *chlorides* of zinc and mercury instead of *sulphates*, obtained a cell whose temperature coefficient is less than 0.01 per cent. per degree, or

more accurately 0.000733 of a volt per degree. These cells also have the peculiarity that their E. M. F., by adjusting the concentration of the  $Zn.Cl_2$ , can be made exactly one volt at any ordinary temperature, so that they can be used as one-volt standards. Weston in America, and Jaeger and Wachsmuth in Berlin, have modified the Clark cell by substituting cadmium for zinc and cadmium sulphate for zinc sulphate. These are known as Cadmium cells, and have an extremely low temperature coefficient. Their behaviour has been investigated by Dr. Henderson, who makes them up in the form shown in Fig. 340. The mercury in the bottom of the test tube has the usual paste of mercurous and cadmium sulphates in contact with it; on this there rest some moist cadmium sulphate ( $Cd.SO_4$ ) crystals, above which is an amalgam of cadmium, consisting of one part by weight of cadmium to six of mercury. The connections to both mercury and cadmium are made by fine platinum wires sealed through narrow glass tubes in the ordinary way, and Dr. Henderson saves the expense of long platinum wires by soldering on copper leads at the point *s* low down in the tubes.

The **H** pattern of standard cell referred to on page 365 was originally devised in 1884, as a modification of the Clark cell, by Lord Rayleigh, with a view to securing the more perfect separation of the various constituents of the cell. When the Board of Trade standards were adopted in 1894 this **H** pattern was superseded by the single tube pattern shown in Fig 338, and for some years all the modifications devised had this general shape. More recently, however, especially in experiments conducted at the National Physical Laboratory, and at Berlin and Washington, the **H** pattern has been revived, as being the more suitable where a high order of accuracy is desired. The following description of the original **H** standard cell has, therefore, not only an historical but also a present-day practical interest.

The cell consisted of two small test tubes, A and B (Fig. 341), connected by a horizontal and narrower tube, fused into each, through which liquid could pass easily. For electrodes platinum wires were fused into the lower end of each limb. In one limb (A) the platinum wire passed into a small quantity of pure redistilled mercury, on the top of which was placed the paste of pure mercurous sulphate ( $Hg_2SO_4$ ) and pure zinc sulphate

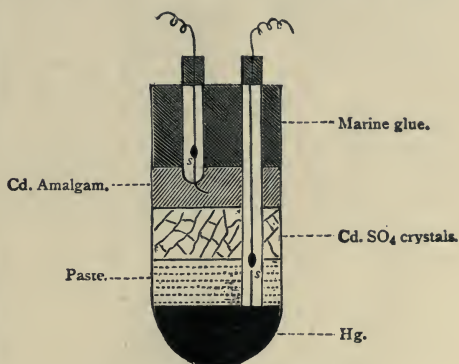

Fig. 340.—Cadmium Standard Cell.

( $\text{ZnSO}_4$ ). In the other limb (B) the platinum wire passed into an amalgam of mercury and pure zinc. The space between the paste, on the one side, and the amalgam, on the other, was filled with a saturated solution of nearly neutral zinc sulphate, a few crystals of the salt being inserted to insure that the saturation should be maintained. The tops of the two tubes were closed with corks sealed hermetically with marine glue. The classical researches of Mrs. Sidgwick and Lord Rayleigh were made with cells of this pattern, and published in 1884. They gave the E. M. F. of the cell as 1.435 volts at  $15^\circ\text{C}$ .

In the modern type of cell recently experimented upon at the National Physical Laboratory by Mr. F. E. Smith cadmium takes the place of zinc throughout, as suggested by Weston in 1892. In preparing the materials for these cells great attention is paid to the preparation of the depolariser,

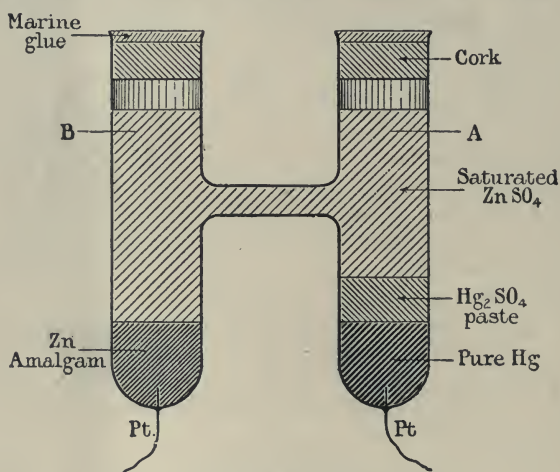

Fig. 341.—Diagram of the H Cadmium Cell.

the mercurous sulphate. To obtain this in a pure state no fewer than four entirely distinct methods have been devised, namely:—

- (i.) Electrolysis ;
- (ii.) Chemical precipitation by the addition of carefully prepared mercurous nitrate,  $\text{Hg}_2(\text{NO}_3)_2$ , to pure sulphuric acid ;
- (iii.) Re-crystallisation of ordinary mercurous sulphate from solution in sulphuric acid ;
- (iv.) The action of fuming sulphuric acid on pure mercury.

The most interesting of these methods is probably the electrolytic one. In the experiments at the National Physical Laboratory the mercurous sulphate was formed at a mercury anode in a solution of dilute sulphuric acid, consisting of one volume of strong sulphuric acid to five volumes of water. The solution was well stirred so as to keep the anode exposed



to the electrolyte, the current density being from 1 to 5 amperes per 100 square centimetres of anode surface. By whatever method prepared, the depolariser was carefully washed first with dilute sulphuric acid, and then with a solution of neutral saturated cadmium sulphate. Finally, the paste consisting of mercurous sulphate and cadmium sulphate was prepared from the above and carefully re-crystallised cadmium sulphate in the proportion of four volumes of mercurous sulphate to one volume of powdered cadmium sulphate. When the depolariser was prepared by methods (ii.) or (iii.) pure mercury was added to the extent of about one-tenth of the whole volume. To the dry powder so formed, sufficient saturated solution of cadmium sulphate was added to form a thin paste. The cells were charged as in the original Rayleigh pattern, crystals of pure cadmium sulphate being introduced into each limb, and the depth of the paste being about half a centimetre. To eliminate entirely any effect due to the material used for closing the upper ends of the test tubes, these upper ends were constricted and finally sealed off skilfully with a blow pipe.

An elaborate research was made on a large number of cells made according to the specification, some at the laboratory, others by careful experimenters elsewhere. In addition twelve cadmium cells were brought to England from the National Bureau of Standards at Washington and directly compared with the normal cells prepared at the laboratory. The differences observed between the E. M. F. of the individual cells and the mean E. M. F. of the other cells of a group was of the order of a few microvolts (millionths of volts) only, and the mean of the E. M. F. of the American cells only differed from the mean of the E. M. F. of the English cells by three microvolts, the English ones being the higher. This is a remarkable result, which would have been considered quite unattainable ten years earlier, and shows that the minute causes of variation have been very thoroughly investigated in the interval. Most of these causes were again investigated, including, for instance, the "effect of the size of the crystals of mercurous sulphate," which was found not to be very serious.

The constancy of the cells at different periods of time after being set up was carefully observed, with the result that 40 out of 50 cells were found to vary by not more than 2 parts in 200,000 after the first month of their preparation. The effect of short-circuiting the cells from 1 to 5 minutes was also examined, and, as might be expected, the result was a temporary lowering of the E. M. F., due to polarisation. The recovery, however, was rapid, occupying only 15 minutes in a cell short-circuited for 1 minute, and about 35 minutes in a cell short-circuited for 5 minutes.

The effect of change of temperature is small, careful experiments at the National Physical Laboratory giving the following results :—

$$E_t = 1.01830 - 0.000034(t - 17) - 0.00000066(t - 17)^2.$$

This equation means that the E. M. F., at the normal temperature of 17° C. is

1.01830, and that a rise of  $1^\circ$  in temperature only changes the value by 3 parts in the last decimal place, the change being a diminution. This result should be compared with that given for the Clark cell on page 366, when it will be noticed that the temperature co-efficient of the cadmium cell is about one-twentieth of that of the Clark. In other words, a change of  $1^\circ$  affects the E. M. F. of a Clark cell as much as a change of  $20^\circ$  affects a cadmium cell. The practical importance of this difference is very obvious.

**Measuring Instruments.**—In physical measurements the method of measurement should be such as not to alter the quantity which has to be measured. An electro-magnetic instrument, however, only approximately fulfils this condition when used for the measurement of pressure, because some current must flow through it, and this tends to alter the pressure. But there is another class of instruments which utilise the strains produced in the electric field near conductors at different potentials, and which in most cases do not disturb the potential differences they are called upon to measure. These instruments have their prototypes in the somewhat crude electroscopes already described (page 54), and are known as "electrometers";

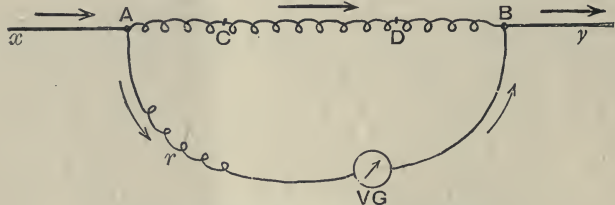

Fig. 342.—Measurement of Potential Differences

but a short space

will be devoted first to the instruments which utilise the magnetic effect of the current.

**Electro-magnetic Voltmeters.**—The same pattern of electro-magnetic instrument which is suitable for an ammeter can also be used for a voltmeter if the conducting circuit be wound differently. For ammeter work the winding consists of a few turns of very thick wire, which has to carry the whole current to be measured, and must therefore be of low resistance, to avoid dangerous heating. As a voltmeter, the instrument *VG*, being required to measure the P. D. between the points *A* and *B* (Fig. 342) in the circuit *ACDB*, is placed in a branch circuit between these points as shown. Now, unless the resistance of this branch circuit *AVGB* is very much greater than the resistance of the main circuit *ACDB*, its introduction may disturb the current flowing in the main circuit, and therefore alter the very P. D. which it is required to measure. Thus the current in *AVGB* must only be a small fraction of the current in *ACDB*, and therefore to get the requisite number of "ampere-turns" a coil of many turns, and necessarily of fine wire, must be wound on. Such a coil, however, will add to the resistance of the branch circuit, and may even have sufficient resistance in itself to satisfy the condition alluded to above; but if not, an additional resistance *r* must

be placed in series with it in the branch circuit. Whatever the resistance, the current in amperes flowing through the galvanometer  $v G$ , multiplied by the resistance in ohms of the branch circuit, will give the P. D. between the points A and B in volts. If the resistance of the branch circuit be kept constant, then the galvanometer can have its scale marked off in volts, and will thus become a *voltgalvanometer*, or more briefly a *voltmeter*.

The ammeters already described, therefore, have only to be wound with fine wire coils instead of thick wire coils, with possibly an added separate resistance included, to be available as voltmeters if properly graduated.

**Hot-wire Voltmeters.**—The heating effect of the current does not lend itself directly to electrical measurements as readily as the magnetic or the chemical effect, because the exact measurement of quantities of heat is a physical operation usually requiring experimental skill of a high order. The heating of materials, however, generally produces physical changes, some of which are more amenable to exact measurement than a quantity of heat; and one of them especially, namely, the expansion caused by increase of temperature, is the basis of a series of instruments originally designed by Major Cardew for voltmeter work.

The principle of such instruments is illustrated in Fig. 343. A long, fine wire,  $A C K D B$ , has its ends, A and B, attached to two hooks, and is kept taut, without being overstrained, by being passed round the pulley L, which is attached by a flexible cord to the spiral spring s. The flexible cord passes round a small pulley  $\phi$ , to the axle of which an index I is fixed to indicate the amount of rotation of the pulley  $\phi$ , and therefore the movement of the cord. If wires P and N be soldered to A and B respectively to supply current, this current will heat the suspended wire, which will therefore expand, allowing the spring s to contract, and to drag the flexible cord round the pulley  $\phi$ . The amount of expansion will be indicated by the movement of the index I on its scale, and when the temperature has become steady the expansion will depend principally on the current passing through the wire, and therefore on the P. D. at the terminals A B. The conditions are somewhat complicated, but by taking certain precautions it can be arranged that for a definite P. D. applied to A B the index I shall take

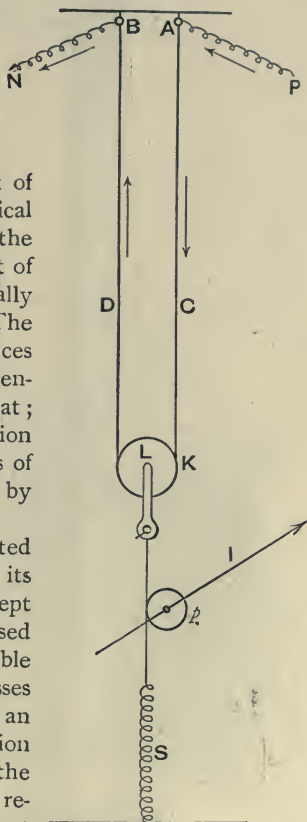

Fig. 343.—Principle of the Hot-wire Voltmeter.



up a definite position on the scale. By applying known P. D.'s to A B, therefore, the scale can be graduated in volts.

The chief working parts of one of Major Cardew's earlier forms of "hot-wire" voltmeters are shown in Fig. 344. The current passing through

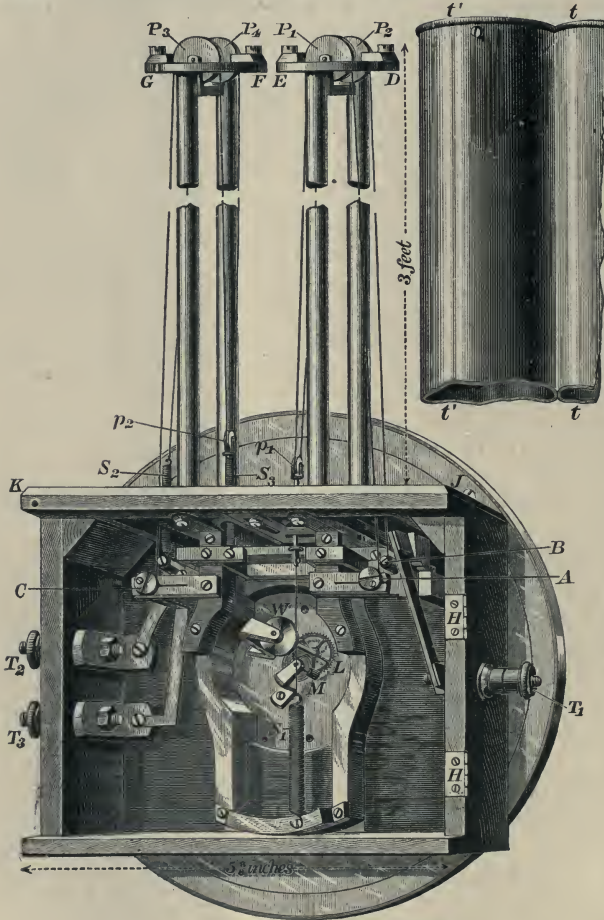

Fig. 344.—Cardew's "Hot-wire" Voltmeter.

the instrument, or rather the terminal volts causing the current, are measured by the extension which the heat generated causes in a fine platinum-silver wire about thirteen feet long. The current entering at  $T_1$  passes first through a fusible cut-out of very fine wire to the screw A. It then enters the platinum-silver wire which passes from A over a fixed ivory pulley P, at the other end of a long tube  $tt$ . From  $P_1$  it passes back along the tube to a movable ivory pulley  $p_1$ , back again to another fixed pulley  $P_2$ , and then back to a fixed block B, to which its other end is attached. The wire thus traverses the tube  $tt$  four times. It is stretched taut by means of a fine cord attached to the block of the movable pulley  $p_1$ ; this cord passes round the wheel w, and is stretched by the spiral spring  $s_1$ . Thus, if the wire lengthens by being heated, the pulley  $p_1$  is drawn down and the wheel w rotates. On the axis of w is a toothed wheel L which gears into a pinion M, whose axis carries the index which

moves over a scale on a dial not shown in the figure. The block  $B$  is electrically connected to the terminal  $T_2$ , so that it is the P. D. between  $T_1$  and  $T_2$  which causes the current in the wire, and which is measured by the indications of the pointer on the dial. A second and similar platinum-silver wire occupies the tube  $t'$ ; its ends are attached to the spiral spring  $s_1$  and the block  $C$ , whilst its movable pulley  $p_2$  is attached to the spring  $s_3$ . Electrically this wire joins the terminals  $T_2$  and  $T_3$ ; its extension is not measured, its purpose being to double the resistance, and therefore to halve the sensitiveness of the instrument, thus practically doubling its range, for the reading when a certain P. D. is put between  $T_1$  and  $T_3$  is only one half as great as when the same P. D. is put between  $T_1$  and  $T_2$ . It is necessary to use a wire similar, and similarly placed, to the working wire for this second resistance, because to double exactly the value of the readings the added resistance must be exactly equal to the resistance of the working wire in the tube  $t$ .

But this latter wire is heated, and therefore changes its resistance with each current. The added resistance must, therefore, vary to exactly the same extent, and this is most readily accomplished in the way described.

**Electrometers.**—In the preceding instruments the electric pressure has been measured indirectly. Thus in the electro-magnetic voltmeters the pressure is measured by the magnetic effect produced by a current produced by the pressure, whilst in the hot-wire voltmeters advantage is taken of the expansion of a wire heated by such a current.

In neither case is the measurement direct, and both methods break down where the conditions are such that the production of a current destroys the pressure or potential difference to be measured, as, for instance, when the potential difference is that of two charged insulated conductors. In such cases the electrostatic methods must be employed, and advantage taken of the electric stresses in the medium between fixed and movable bodies brought to the potentials the difference of which it is required to measure. If the instruments are sufficiently sensitive they can also be used to measure

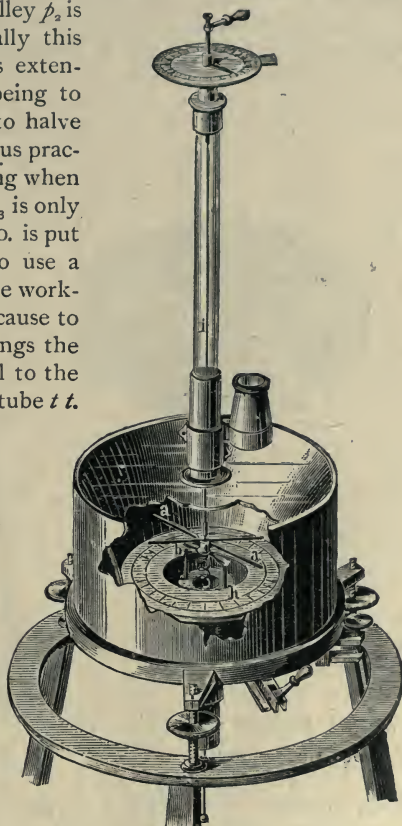

Fig. 345.—Kohlrausch's Torsion Electrometer.

any potential differences, including those between two points in a circuit through which a current is flowing.

The instruments, as previously explained, are known as electrometers, and an *electrometer* may be defined as an instrument for *measuring electric pressures by means of the electrostatic strains in the dielectric*.

Electrometers are simply electroscopes in which the effect produced by the strains in the dielectric is *measured* instead of being *indicated* only.

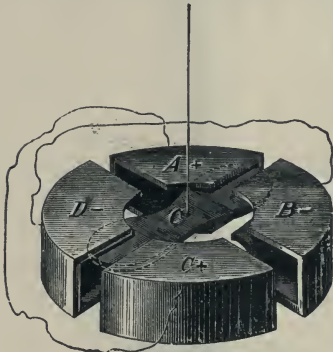

Fig. 346.—The Quadrants in Lord Kelvin's Electrometer.

Attempts to make such measurements, with more or less exactness, date from an early time in the history of the science, but it was only during the nineteenth century that the labours of Kelvin, Kohlrausch, Dellman, and others resulted in the production of reliable instruments.

Kohlrausch's "Torsion Electrometer" is illustrated in Fig. 345. The arm *a a*, which is bent downwards in the middle, is made of silver, and fixed by means of the pieces of shellac *b b*. The suspended arm, also of silver, hangs by the glass thread *i* in such a manner that it is able to rotate in the same horizontal plane as the straight parts of *a a*, in consequence of the bend in the latter. The spiral wire below the suspended arm is used to establish electrical connection, and the instrument is used for taking measurements in a way similar to that in which the "Torsion balance" is used.

*The Quadrant Electrometer.*—The characteristic features of this instrument are the following: A light body connected with the inner coat of a Leyden jar, by which it is charged, hangs near two bodies whose electric

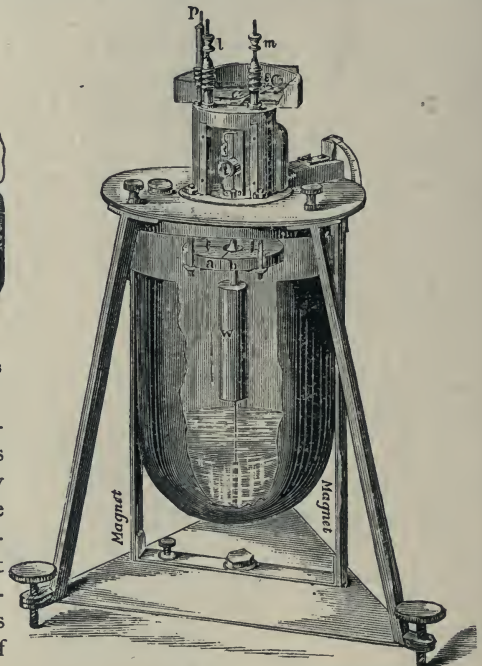

Fig. 347.—Lord Kelvin's Quadrant Electrometer.



potential-difference is to be tested. The difference of electrical condition is measured by the resultant attraction of the light body. In Lord Kelvin's instrument the light body is a very thin aluminium needle *c*, shaped like a figure 8, as shown partly by dotted lines in Fig. 346 and being within the quadrants *a b* in Fig. 347. This flat needle is hung by a wire from an insulated stem above a Leyden jar with hemispherical base (Fig. 347). This Leyden jar contains strong sulphuric acid, which forms its inner coating. A wire stretched by a weight *w* dips into the acid, and connects the needle with this inner coating. The needle carries a small mirror, which serves to indicate the deflection by reflecting a beam of light on to a scale. The needle *c* hangs inside four quadrants *A +*, *B -*, *C +*, *D -* (Fig. 346), insulated by glass stems, by which they are supported from the body of the instrument. The quadrant *A +* is in electrical connection with *C +*, and *B -* is in connection with *D -*, as shown by the wires in the figure.

Let us suppose the needle *c* charged to a high negative potential; then, if the quadrants are symmetrically placed, it will deflect neither to the right nor to the left, so long as *A +* and *B -* are at the same potential. If *B -* be negative relatively to *A*, the end of *c* under *A* and *B* will be repelled from *B* towards *A*, and at the same time the other end of *c* will be repelled from *D* towards *C*. The motion will be indicated by the motion of the spot of light reflected by the mirror, and as the controlling force is the torsion of the suspending wire, the deflection will be sensibly proportional to the difference of potential between *A* and *B*. The number of divisions which the spot of light traverses on the scale will, therefore, measure the difference of potential between *A* and *B*. This instrument is, therefore, an electrometer, and not a mere electroSCOPE.

Two terminals *lm* (Fig. 347) serve to charge *A* and *B*. They can be lifted up out of contact with *A* and *B* after charging them. The third terminal *p* is attached to a little electrical influence machine inside the jar, called a *replenisher*, by which the charge of the jar can be increased at will. There is also a gauge by which the constancy of the charge can be measured, and the sensitiveness of the instrument maintained unchanged. Some of these instruments are made so sensitive as to give a deflection of one hundred divisions for the difference of potential between zinc and copper in contact.

Many modifications of Lord Kelvin's Quadrant Electrometer have been devised, but of all these we can only refer to two. A simple form, due to Professor Clifton, of Oxford, is shown in Fig. 348. The quadrants are supported on glass pillars, and the terminals, *TT*, are brought down through openings in the bottom of the case, which can be closed by plugs when the instrument is not in use. The insulated rod, *R*, is for the purpose of charging the Leyden jar: *S* is a tangent screw by which the exact orientation of the needle in the quadrants can be adjusted, and *VV* are vessels for containing some desiccating substance for keeping the

upper part of the case dry. The suspension is bifilar, and furnishes the requisite control whilst insulating the needle; the Leyden jar can be removed from below without lifting off the cover.

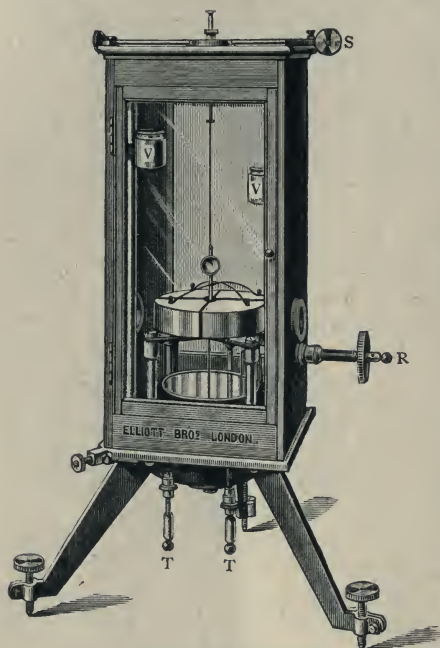

Fig. 348.—Clifton's Quadrant Electrometer.

A more recent form of Quadrant Electrometer, as devised by Professors Ayrton and Perry and Dr. Sumpner, is shown in Fig. 349. In this the quadrants are much smaller than in the Clifton pattern; they are supported on glass rods, *r, r*, and the terminals, *T, T*, are, as before, brought down through holes in the base plate. The standards *S, S*, which carry the suspension, are likewise supported on glass insulating rods; they also carry the guard ring which protects the mirror from being influenced by external electrifications. The mirror, which is made as small as possible, and the needle, which is of the ordinary shape, are carried by a torsionless fibre suspension. The former has

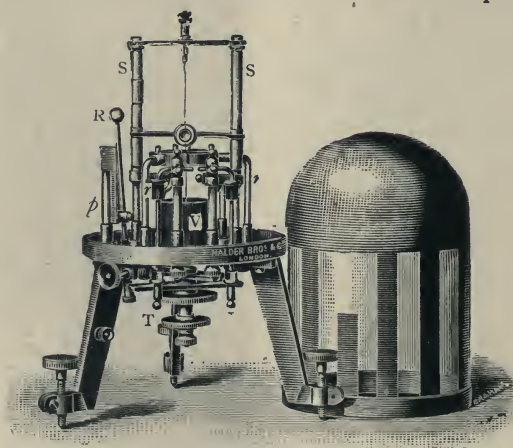

Fig. 349.—Ayrton, Perry & Sumpner's Quadrant Electrometer.

fastened behind it little magnets similar to those used in galvanometers. In this case, however, they are for controlling purposes only, the control being effected by the action on them of a pair of scissors magnets, carried on the central stem below the base plate. The leaden vessel *V* contains strong sulphuric acid, which will keep the interior dry when the cover is on, and which also, by its viscosity, will damp the motion of the needle by acting on a

little platinum vane which dips into it, and is rigidly connected by a platinum wire to the needle.

The most striking modification in this instrument is the Leyden jar for charging the needle. This is formed by the glass cover, which is coated internally and externally with tinfoil in the usual way, additional strips, however, being added to the external coating for screening purposes. The internal coat is charged by the rod R, which is carried on a pivot by the insulating pillar  $p$  in such a way that the connection with the coating can be broken by pushing the knob out of contact.

In measuring small E. M. F.s and P. D.s with a quadrant electrometer the Leyden jar, and therefore the needle, is charged up to a high potential, and the two points whose potential difference is required are connected to the terminals. The deflection is then sensibly proportional to the P. D. A more exact law is given by the equation :

$$\delta = k(V_1 - V_2) \left( N - \frac{V_1 + V_2}{2} \right)$$

in which  $N$  is the potential of the needle,  $V_1$  and  $V_2$  are the potentials of the points under test,  $\delta$  is the deflection, and  $k$  a constant to be determined by a preliminary calibration. If  $N$  be large as compared with  $(V_1 + V_2)$  the equation becomes

$$\delta = kN(V_1 - V_2) \text{ nearly,}$$

and  $\delta$  is sensibly proportional to  $(V_1 - V_2)$ . A good instrument can be made sufficiently sensitive to give considerably over one hundred divisions for a P. D. of one volt. In electrometer working special attention must be paid to details of insulation.

*Electrostatic Voltmeters.*—For measuring the higher pressures met with in electric lighting, power and traction circuits, less sensitive electrometers of a more portable type are required. They are usually designed to work *idiostatically*, that is, by means of the strains set up by the potentials to be tested, and without the assistance of any additional electrification such as is given to the needle in the quadrant electrometer. They will be described in the technological section of the book, for which also is reserved the description of the modern apparatus for applying the potentiometer method (*see* page 362) of comparing these higher P. D.s with the E. M. F. of a standard cell.

#### V.—ELECTRIC POWER.

Power is defined as the *rate of doing work*, and electrical power due to electric currents is, therefore, the rate at which work is being done electrically in a circuit or portion of a circuit. It can be shown that this power is represented *at any instant* by the product of the pressure and the current at that instant. If the whole circuit is being dealt with, then the pressure is the whole impressed pressure or E. M. F., and the current is the total current in the circuit, thus, in continuous current circuits :—



$$\text{Power} = \text{E. M. F.} \times \text{current} \quad (\text{i})$$

or

$$W = E \times C \quad (\text{ii})$$

If  $E$  be measured in volts and  $C$  in amperes the product of the two might be called *volt-amperes*, and this name was used for some time. Eventually, however, it was displaced by the term *watts*, in honour of James Watt, who did so much to advance exact ideas on the subject of power. We have therefore the equation

$$\text{Watts} = \text{Volts} \times \text{Amperes} \quad (\text{iii})$$

It is perhaps worthy of note, as showing the cosmopolitan character of electrical terms, that the three scientists whose names are used in the above equation are of three different nationalities. Other similar instances will occur as we proceed.

In equation (i) above, if the E. M. F. referred to is that of the generator of the current in the circuit, then the E. M. F. and the current are in the same direction, and the power represented by the product is the rate at which the generator is giving energy to, or is doing work on, the circuit. In dealing with a portion of a circuit, however, it may happen, as for instance when a secondary battery is being charged, that an E. M. F. at some point of a circuit is opposed to the current which is passing, or, in other words, is a *back E. M. F.* In such cases the above product is *negative*, and represents the rate at which electrical energy is being taken from the circuit and converted into some other form of energy. In the instance cited, that of the charging of a secondary battery, the electrical energy is being converted into energy of chemical separation, and most of it is being stored as such.

The analogous hydraulic case may help us here. Imagine a centrifugal pump placed at the bottom of a vertical shaft, and driven by a steam engine so that it forces water up the shaft. There will be a difference of pressure between the suction-pipe and the delivery pipe of the pump, the pressure in the delivery pipe at the bottom of the vertical shaft being greater than the pressure in the suction pipe. The rate at which the pump is giving hydraulic energy to the water is measured by the product of this increase of pressure (or hydraulic E. M. F.) and the quantity of water delivered per minute (*i.e.* the current).\* Now, let the current be reversed whilst the pump continues to revolve in the same direction, and therefore continues to set up the same difference of pressure which is, however, opposed to the direction of the current. In this case the pump will act as a turbine or hydraulic motor, and will take energy from the water, which can be utilised to drive machinery or do work. The rate at which this energy is taken from the water and absorbed by

\* It is assumed that the water is moving with the same velocity before and after passing the pump.

the turbine is again measured by the product of the (back) pressure and the current.

In a portion of a circuit *in which there is no source of E. M. F.*, the electrical power is also measured by the product of the P. D. (V) and the current (C), and remembering that we have  $V = C.R.$  in such a portion of a circuit we may express the electrical power in any one of the three forms—

$$W = VC = C^2 R = \frac{V^2}{R}$$

The electrical energy in this case is all being transformed into heat, and the rate at which this heat is being generated may be expressed by any of the three last terms, though the second ( $C^2R$ ) is the one most usually employed.

With steady currents the electrical power can be measured by using a voltmeter and an ammeter to measure the pressure and current respectively, and then the product of the two readings will give the number of watts. But it obviously will be more convenient as regards the measurement of power if we can devise an instrument whose readings depend on the required product, and whose scale can therefore be graduated in watts. Such an instrument is called a *wattmeter*.

Before describing the instruments it may be pointed out that power, or rate of doing work, is an engineering quantity, and therefore there should be some relation between the electrician's unit of power, the watt, and the engineer's unit of power, the horse-power, which is 33,000 foot-lbs. per minute, or 550 foot-lbs. per second. The relation does exist, and is given by the equation

$$746 \text{ watts} = 1 \text{ horse-power.}$$

**Wattmeters.**—From the above it will be obvious that an instrument which is to measure the electrical power in a circuit or a portion of a circuit should be designed so that its indications depend either directly or indirectly upon the product of the current passing and the pressure applied. Electro-dynamometers and current balances lend themselves readily to the conditions. In these instruments, to be described later, the reading depends upon the product of the current in a movable coil and the current in fixed coils, and when used as ammeters or voltmeters these coils are joined in series, so that the current is the same in both. But the two sets of coils may be disconnected, and one of them, preferably the fixed coil, may be made to carry the whole of the current in the circuit, whilst the other, or movable coil, may be wound with a wire of high resistance and so connected up that it carries a current proportional to the pressure. The indications of the instrument will depend upon the product of these two currents, that is, upon the product of amperes by volts—in other words, upon the watts.

The method of joining up these instruments to the circuit to be tested is shown diagrammatically in Fig. 350.  $BD$  and  $CF$  are the mains supplying energy to circuits between  $D$  and  $F$ . One of these mains ( $BD$ ) is cut, and the sides of the break joined to  $a$  and  $b$ , the terminals of the thick wire or ammeter coils  $A$  of the wattmeter. The terminals  $c$  and  $d$  of the fine wire or voltmeter coils  $V$  are connected, one to each main, and frequently in this circuit an additional resistance  $R$ , which is kept constant, is introduced to fulfil still better the conditions of voltmeter working (*see* page 370). The instrument being so constructed that its indications depend on the *product* of the currents in  $A$  and  $V$ , these indications will measure the power in *watts* which is being used between the points  $D$  and  $F$ .

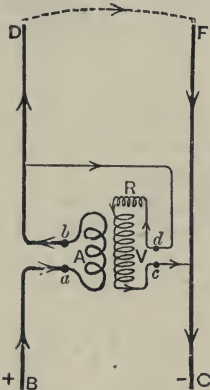

Fig. 350.—Connections of Electro-Magnetic Wattmeter.

#### VI.—ELECTRIC ENERGY.

The correct measurement of electric energy is one of the most important problems which has been brought to the front by the development of the dynamo machine and the supply from central stations of large quantities of electrical energy for diverse purposes. It is, of course, useful to know the current, the pressure, the power, etc., but, above all, the consumer is concerned with the total energy delivered to him, for it is this which performs the work which he requires to be done, whether it be mechanical work or chemical work, as in electro-plating, or heating, as in the use of electric radiators, etc., or lighting either by arc or glow lamps, though in the latter case much of the energy is wasted if the only object be to produce light.

It is not one of the least of the achievements of modern electrical science that it has introduced into every-day life the actual buying and selling of energy *as* energy, directly and not indirectly. It is true that when we buy fuel or gunpowder, or even food, what we really desire to make practical use of is the energy stored in the commodity dealt with. But we do not measure or buy the energy as such; what we do purchase and take delivery of is so much mass, so many pounds or what not, of the material from which by well-known methods we hope to obtain the energy we desire.

What, then, is energy, or rather, when may a body or system be said to possess energy? The reply to the latter question is that a body or system possesses energy when it is *capable of doing work*. The amount of energy is measured by the amount of work that can be done in the most ideally favourable circumstances. The energy is indestructible; but during the performance of the work it usually changes its form and passes to other bodies or systems. Space,



however, will not allow us to pursue further this interesting part of the subject.

We have seen above that power is the *rate* of doing work. If this rate, that is, if the power, be kept constant for any period of time, the total amount of work done will be given by the product of the rate by the time. In other words:—

$$\text{Energy} = \text{Power} \times \text{Time.}$$

The electrical unit of power is the watt, and the electrical unit of time is the mean solar second; the electrical unit of energy must therefore be the work done by one watt in one second. This unit is known as the **Joule**, in honour of the great English experimenter of that name. We therefore have:—

$$\text{Joules} = \text{Watts} \times \text{Seconds}$$

Expressed in engineers' ordinary units of energy,

$$\text{One joule} = \text{One foot-lb.} \times 0.737.$$

For ordinary purposes the Joule is too small a unit to be convenient, and therefore a much larger unit, known as the *kilowatt-hour* or *Board of Trade unit* (B.T.U.), has been brought into use. In this unit the power is measured in kilowatts (thousands of watts) and the time in hours instead of seconds. Thus:

$$\text{Board of Trade Units} = \text{Kilowatts} \times \text{hours,}$$

or

$$\begin{aligned} \text{One B.T.U.} &= 1,000 \times 3,600 \times \text{joules.} \\ &= 3,600,000 \text{ joules.} \\ &= 2,654,000 \text{ foot-lbs.} \end{aligned}$$

This Board of Trade unit is, in these islands, the statutory unit which appears in the accounts rendered to their customers by the electric lighting and power companies.

**Instruments.**—What we want, then, in an instrument for measuring electrical energy is an instrument which shall either add up, or produce a record which will enable us to add up or integrate, as it is technically called, all the products of power by time throughout the whole period during which the power is being supplied. In the first case the instrument might be called an adding-up or *integrating wattmeter*, though a better name would be an *energy meter*. In the second case it would be sufficient to have a *recording wattmeter*, which would record the number of watts at every instant, so that from this record the total energy could be measured up or calculated. We propose now to describe some early forms of energy meters which are of historic interest.

**Energy Meters.**—The first which we shall describe may be called a "clock" meter, since the power supplied simply controls the rate of

going of a clock, the clock being accelerated proportionately to the power. The principle employed was originally suggested and used by Professors Ayrton and Perry, who in 1882 constructed an energy meter in the form of a clock whose pendulum was electro-magnetically controlled. The idea was modified by Dr. Aron, and one of the early forms which he devised, and which at one time was largely used, is shown in Fig. 351. Two separate clocks, each controlled by its own pendulum, were mounted on the same base plate. The last wheels of the train of each clock were so geared together that if the clocks were going at the same rate the counting dials seen in the figure were not affected. If, however, one clock gained on the other, the dials registered

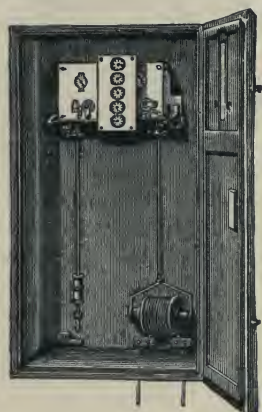

Fig. 351.—Dr. Aron's Energy Meter.

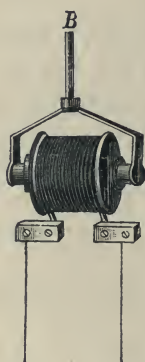

Fig. 352.—Bob of Energy Meter.

the total gain. One of the pendulums, that on the left, was an ordinary pendulum with the usual adjustments, but the other had a bob, shown on a much larger scale in Fig. 352, consisting of a solenoid of fine wire, which swung inside a larger and fixed solenoid of thick wire. The fine wire solenoid was put as a shunt across the supply mains, and thus took the place of the fine wire or voltmeter coil of a wattmeter, whilst the thick wire coil carried the whole current supplied and acted as the ammeter coil of the wattmeter. The joint effect of the currents in the two coils on the rate of swing of the pendulum was proportional to the products of those currents, that is, to the volt-amperes or watts supplied. Thus, the right-hand clock was made to err at a rate proportional to the watts, and therefore the total error in a given time was proportional to the total energy supplied. This error was indicated by the readings on the dials, which thus registered the energy consumed.

The next meter is one of a very large class of meters which are in reality small electric motors, so controlled that the speed of rotation of the armature is proportional to the power that is being supplied, and therefore the total number of revolutions of the armature, which can be automatically counted quite easily, measure the total energy. The great difficulty is to ensure the above-mentioned proportionality between speed and power, and many are the devices adopted for the purpose. Another, though minor, difficulty is to reduce the frictional resistances so far that the armature will rotate even when the power to be

measured is only a small fraction of the maximum for which the meter is designed.

The particular meter illustrated in Fig. 353 was designed by Professor Elihu Thomson, and is, though somewhat modified, very widely used. The two large fixed coils which are so prominent are the field-magnet coils of the motor; they carry the total current supplied, but have no iron cores, the magnetic circuit of this curious electric motor being composed entirely of non-magnetic materials. The armature is mounted upon a vertical spindle, and rotates between these coils. It is wound with fine wire, which, in series with a non-inductive resistance, is placed as a shunt across the mains, and therefore transmits a voltmeter current. Now it can be shown

that the turning moment acting on the movable armature is proportional to the product of the current in the two coils—that is, to the watts supplied to the consumer. If, therefore, we can make the opposing moment proportional to the steady speed of rotation, that speed will be proportional to the watts, which is just what is required. The result is achieved by means of the magnetic brake seen in the lower part of the figure. A horizontal disc of copper is fixed to the spindle, and three strong horseshoe magnets, with their poles close to one another,

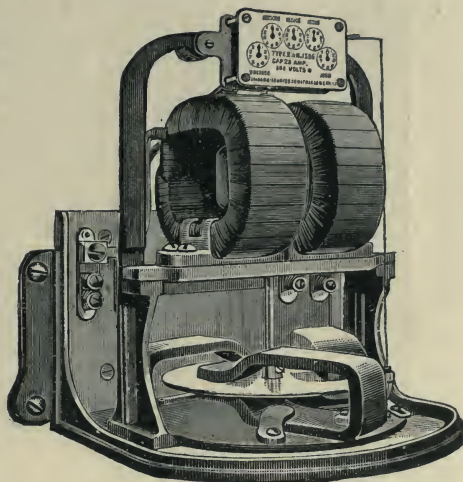

Fig. 353.—Professor Elihu Thomson's Energy Meter.

but on opposite sides of the disc, are fixed so that the latter rotates freely between them. The copper disc, as we shall explain later, rotating in these strong magnetic fields, has currents set up in it, which by their reaction on the fields retard its motion, and the retarding couple is proportional to the speed. By adjusting the position of the magnets the counting dials which record the revolutions of the armature can be caused to indicate Board of Trade units.

**Coulomb-meters.**—The factors of electric current energy being the current ( $c$ ), the pressure or potential-difference ( $v$ ), and the time ( $t$ ); or in symbols

$$W = V C T,$$

it is obvious that if the pressure  $v$  be kept constant it will be sufficient to measure the product  $c t$ . The product of amperes and seconds gives



quantities of electricity of coulombs (*see* page 195), and coulomb-meters are instruments which record the total value of the product  $c \tau$  when a current, either steady or otherwise, is passed through them for a definite time  $\tau$ . To get the value of the energy their indications must therefore be multiplied by the mean value  $v$  of the potential-difference. On the other hand, energy meters give at once the value of the product  $v c \tau$ , and therefore follow the changes in  $v$  as well as those in  $c$ .

The first form of meter used for public supply purposes was invented by

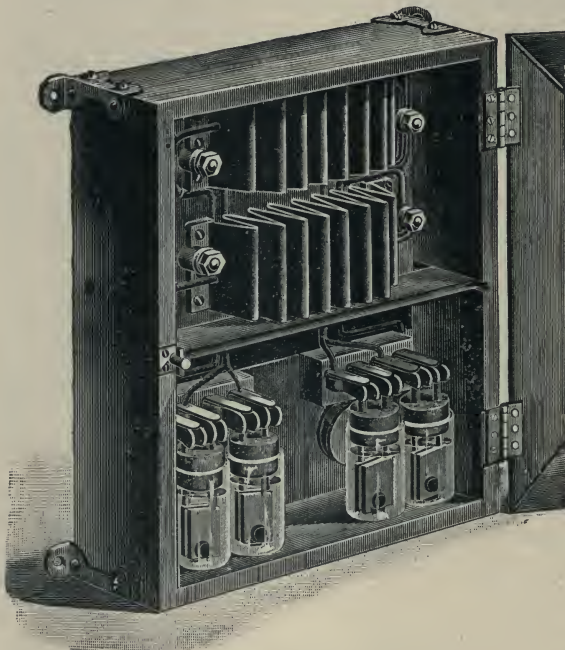

Fig. 354.—Edison's Public Supply Meter.

Edison, and was based on the principle of the voltameter explained at page 192. As the weight of the ions separated in a voltameter is proportional to the total quantity of electricity that has been passed through, all instruments of this type are essentially coulomb-meters. Edison made use of a zinc voltameter, that is, a voltameter consisting of plates of zinc in a solution of zinc sulphate; the weight of zinc deposited on the kathode directly measured the total number of coulombs supplied to the consumers, and these multiplied by the volts and

divided by 3,600,000 ( $3,600 \times 1,000$ ) gave the number of Board of Trade units delivered.

The early forms of the Edison coulomb-meter will be found described in the first edition of this book. A more recent form, embodying many improvements suggested by experience, is depicted in Fig. 354. It is known as the "Standard Three-Wire Meter," since there are two circuits through the meter, so that current drawn from either side of a three-wire system will be measured. The conductors leading from the external wires of the distributing mains are cut, and the gap in each case bridged by one of the circuits of the meter. Taking one of these circuits, the bulk of the current passes

through one of the zigzags of stout German-silver strip seen in the top of the case. The voltmeters are placed in a branch circuit, so that only a definite fraction of the total current passes through them. This branch circuit contains not only the voltmeter, but also a coil of fine copper wire, which can be seen behind the voltmeter on the right, and whose resistance still further diminishes the current through the voltmeter. The copper coil has, however, a still more important function. It is, of course, necessary for accurate work that the ratio of the currents, and therefore the ratio of the resistances of the main and branch circuits, should remain the same at all temperatures. Unfortunately, however, the resistance of zinc sulphate varies widely with change of temperature, diminishing as the temperature rises. Copper also varies, but in the opposite direction, whilst the variation of German-silver is but slight. It can readily be seen, therefore, that by combining a proper resistance of copper with the zinc sulphate in the branch circuit, the resistance of that circuit can be made to vary proportionately with that of the German-silver in the main circuit, and thus the ratio of the two, and therefore the ratio of the currents in them, will remain constant.

Each voltmeter consists of two vessels, each containing two plates made of zinc cast with two per cent. of mercury. As can be seen in the figure, the two vessels of the voltmeter are in parallel with one another, so that the current divides between them, and chemical action takes place in each, zinc being deposited on the kathodes and dissolved off the anodes. The meters are periodically inspected, and at definite intervals the voltmeters are replaced by others, the old ones being taken to the station, where the plates are weighed, and the account for the energy supplied calculated from the weighings.

The meters are made in four standard sizes, numbered 1, 2, 4, and 8 respectively. The resistances are so proportioned in the various sizes that the deposition of 10 milligrammes of zinc in the voltmeter denotes the number of ampere-hours indicated by the number of the meter. Thus, in No. 4 meter the deposition of the above weight of zinc measures the passage of 4 ampere-hours of electricity. An ampere-hour is 3,600 coulombs.

One great disadvantage of voltametric meters is, that it is impossible with them for the consumer to ascertain his consumption from time to time, and thus be in a position to check any waste that may be going on. The majority of modern meters are therefore so designed that the energy consumed is indicated on a dial or dials like those of a gas-meter, so that the consumer can readily read off the amount of energy used up to the time of reading.

A simplified form of the Aron energy meter has been largely used as a coulomb-meter to measure the energy on constant pressure circuits. In this form (Fig. 355) the complicated pendulum bob shown in Fig. 352 is replaced by a simple magnet *M* attached to the end of the pendulum rod, and swinging over a solenoid *s* of thick wire, placed with its axis vertical, and carrying the whole current in the circuit. The alteration of the rate of swing

of the right-hand pendulum will depend upon the magnetic effect of the current in the solenoid, since the magnetism of the swinging magnet is constant. But as the solenoid has no iron core its magnetic effect will be strictly proportional to the current in the wire. Thus the alteration in the rate of swing will be proportional to the current, and since the total effect of these alterations is shown by the dials the indications of the latter will be proportional to the total coulombs that have passed through s.

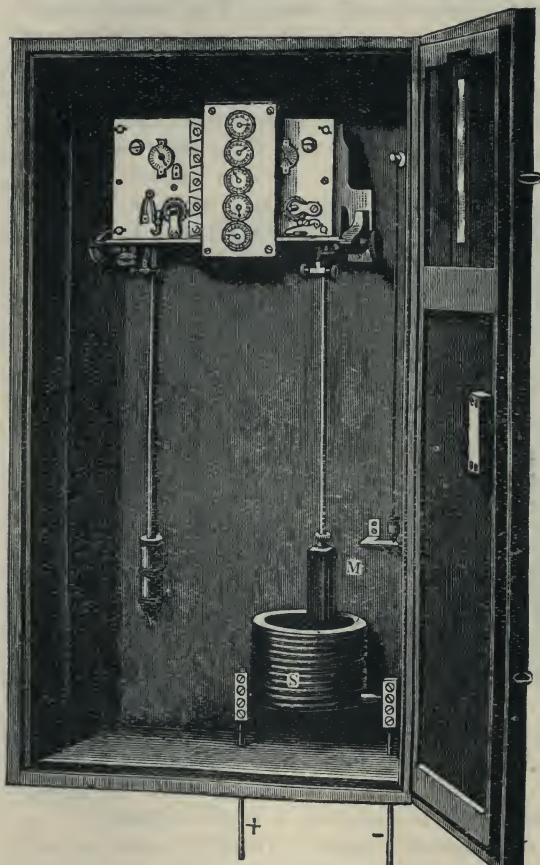

Fig. 355.—Aron's Coulomb Meter.

Many other forms of coulomb-meters, and also of energy-meters, were devised during the first few years of the development of the public supply of electric current energy for lighting and power purposes, and some of them are certainly of historical interest. Space, however, will not allow us to enter into details of these, and we must now reserve the further consideration of measuring instruments and measurements in continuous current circuits for the technological section of the book, in which we propose to describe some of the more important instruments in use at the present time.



## CHAPTER X.

*FURTHER APPLICATIONS OF THE EFFECTS OF THE CURRENT.*

THE magnetic effect of the current was soon after its discovery pressed by inventors into the service of man for purposes other than those of measurement, and the early attempts to utilise the mysterious mechanical and chemical forces developed have long since passed into the history of the science. Before dealing with other fundamental discoveries and their developments we may pause here to dwell upon the application of the phenomena and principles, which have now been described, in a direction which produced the most profound social changes in the latter half of the nineteenth century. We are still too near in point of time to estimate in all its bearings the influence which the development of telegraphy has had upon the history of the race, but it is certain that the philosopher of the future will assign no mean place to this department of applied science when examining the sociology of the last century. The pages next following will therefore deal with

*THE ELECTRIC TELEGRAPH.*

## I.—EARLY HISTORY.

Experiments in telegraphy were made as far back as the year 1753, when it was proposed to represent letters by combinations of sparks, etc.; but these were of little practical value before the discovery of the electric current and its properties.

The earliest proposal to use the transmission of electricity for the communication of signals appears in the *Scots Magazine* for February, 1753, where a correspondent from Renfrew, who signs himself C. M., proposes several kinds of telegraphs acting by the attractive power of charges of electricity, conveyed by a series of parallel wires, corresponding in number to the letters of the alphabet, and insulated by supports of glass or jewellers' cement at every twenty yards. Words were to be spelt by the charges attracting letters, or by striking bells corresponding to letters. One Le Sage, of Geneva, in 1782, proposed to convey twenty-four insulated wires in a subterranean tube, and to indicate the letters of the alphabet by means of the attraction of light bodies. In 1811 Sömmering suggested a similar application of voltaic electricity, chemical decomposition being the effect

observed; and as, to a certain extent, he carried his suggestion into effect, he is sometimes regarded as the first who made a practical telegraph.

Samuel Thomas Sömmering was born in 1755, at Thorn, studied medicine at Göttingen, and became Professor of Anatomy at Kassel. He was led by a suggestion of the Minister Montgelas to use the voltaic current in telegraphy in the following manner:—When the Austrian troops crossed the Inn, 1809, and entered Bavaria, King Maximilian fled, in company with Montgelas, to Dillingen; here he was surprised by the unexpected arrival of Napoleon. At this time Chappe's optical telegraph was used in France, and through it Napoleon had obtained the news of the crossing of the Austrians sooner than had been expected, and the consequence was that Munich, which

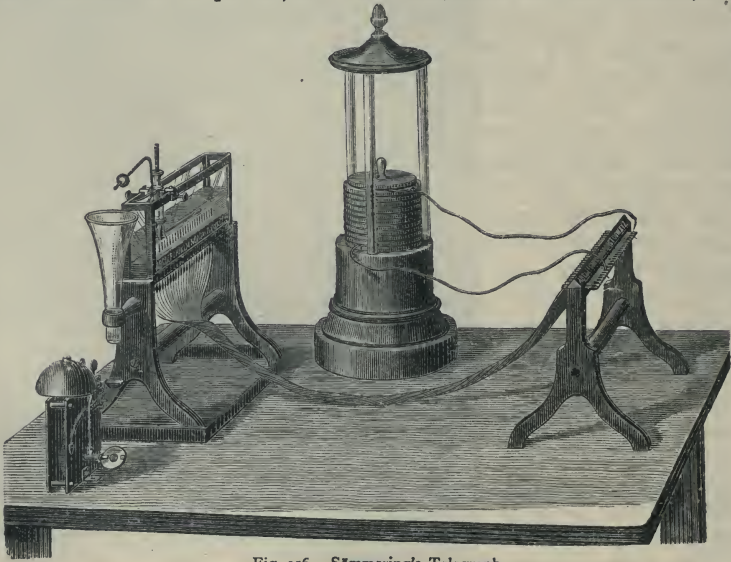

Fig. 356.—Sömmering's Telegraph.

had been taken on the 16th of April, was retaken by Napoleon on the 22nd of April, so that Maximilian was able to return to his capital the same month. The prominent part which the method of signalling had played in this important event caused Montgelas to ask the Academy to lay proposals before him for a system of telegraphy. Although Montgelas can only have had in mind the optical telegraph, Sömmering conceived the notion of making use of the electrolysis of water by the galvanic current for this purpose. His experiments commenced on July 8th, 1809. On the 6th of August he telegraphed through a length of wire of 724 feet, and on the 18th of August through a wire 2,000 feet long. His apparatus is shown in Fig. 356. It contained twenty-seven wires for the twenty-five letters, together with stop and repeating signs. These wires are covered with an insulating substance,

and twisted so as to form a cable. One end of each wire ended in a gold pin which was cemented in the bottom of a rectangular flat glass box filled with water; the other end was connected with a frame containing twenty-seven connecting pivots, each of which was lettered. A voltaic pile, consisting of fifteen Brabant thalers, zinc discs, and felt impregnated with a solution of ordinary salt, was used as a battery. The poles of this battery ended in plugs, which were inserted in two holes of the pivots, and hydrogen and oxygen were then evolved at the corresponding gold pins, and by seeing at which pole the gas was produced the observer told which letter it was intended to signal. Sömmering further combined with this apparatus an alarm, as shown in the figure. A spoon-shaped glass vessel, placed so as to catch the escaping H and O of two gold pins, was connected with an angular lever; the horizontal arm of the lever reaching out of the glass box loosely supported a leaden ball. When the evolution of gas commenced the spoon was raised, the protruding arm of the lever was lowered, and the leaden ball allowed to fall through a glass funnel upon the lever of a clock, which made the bell ring. Sömmering's apparatus was never applied to practical use.

In 1819 the deviation of the magnetic needle through the action of an adjacent electric current became known, and Ampère, in 1820, and Fechner, in 1829, showed how to make use of this fact for telegraphic purposes. Ampère's plan was to use thirty needles and sixty wires; Fechner's twenty-four needles and forty-eight wires; for at first it was supposed that there must be a separate needle for each letter or sign signalled; these proposals, however, came to no practical results.

Baron Schilling constructed an electro-magnetic telegraph in 1832 by making use of the multiplier devised by S. Ch. Schweigger (*see* page 345); but the first electro-magnetic telegraph of which practical use was made was the telegraph constructed by Gauss and Weber at Göttingen, in 1833, with a line of 3,000 feet of wire.

The original apparatus was sent to the Exhibition at Paris in 1881, and has been described in *La Lumière Electrique* (vol. viii.). It is represented in Fig. 357. BB is a galvanometer frame in which the magnet A, 3.97 feet in length, carrying a small mirror M, is suspended by means of a silk thread. The sender consisted at first of a simple galvanic battery, for which the induction apparatus shown in Fig. 358 was afterwards substituted. Two large magnets A, each weighing 25 pounds, were arranged vertically upon a frame so that their north poles projected above the frame. The induction coil B was placed loosely about the middle of the magnets, so that it could be moved freely by means of handles. The ends of the coil B were connected with the coil in the galvanometer frame. A quick motion of the coil generated an induced current, which reached the galvanometer frame through the wires, and caused the magnetic rod to be deflected. The direction of deviation was determined by the direction in which the coil was moved, and it is evident that by combinations of these deflections a whole alphabet could be formed.



To simplify the manipulations, a double lever *L* was added, which moved a

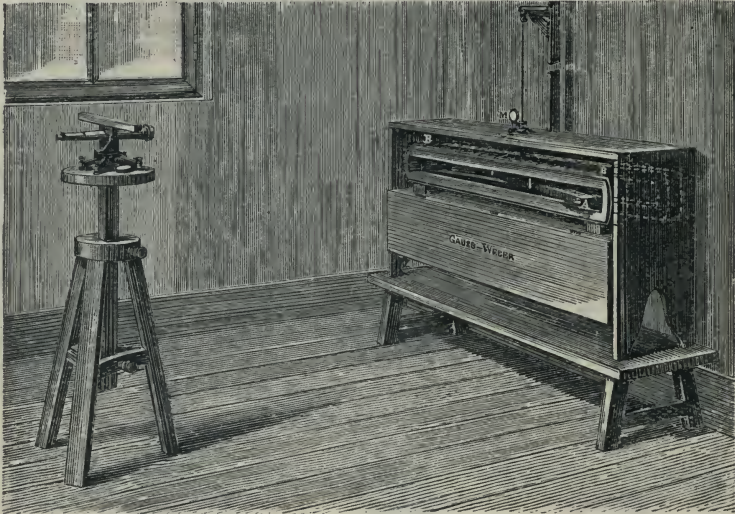

Fig. 357.—Gauss and Weber's Telegraph.

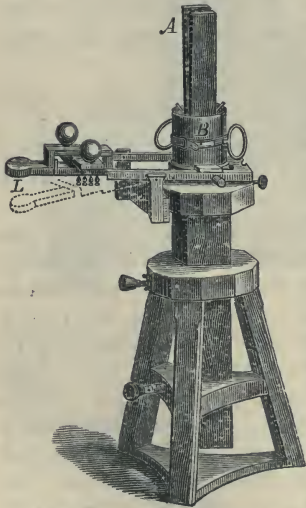

Fig. 358.—Gauss and Weber's Sending Apparatus.

commutator as well as the coil. The call signal was given by means of a bell and clockwork.

In the year 1837 three independent inventors described practical systems of telegraphy. They were Carl August Von Steinheil, of Munich, who had been a pupil of Messrs. Gauss and Weber; Sir Charles Wheatstone, of London; and Mr. Morse, of the United States. The telegraphs of the two first resembled in principle Oersted's and Gauss's; that of the last consists in making a ribbon of paper move by clockwork, whilst interrupted marks are impressed upon it by a pen or stamp of some kind brought in contact with the ribbon by the attraction of a temporary magnet, which is excited by the circulation of the telegraphic current. By the telegraph of Wheatstone the needle moves only to the right or left, and by the combination of a certain number of right and left motions, either with one or two independent needles acted on at once by distinct currents, the alphabet is easily, though somewhat tediously, constructed.

It thus appears that we cannot claim the exclusive invention of electric telegraphy for any one individual. But of the several inventors none probably showed such perseverance and skill in overcoming difficulties as Wheatstone. His telegraph, accordingly, was in general use in England before Von Steinheil was able to obtain a similar success in Germany.

To Steinheil must be further ascribed the discovery of the possibility of conveying the returning electric current back through the earth, a discovery which was of the greatest utility in the further development of telegraphy; indeed, no discovery is perhaps more deserving of notice on account of its importance than this of the apparently infinite conducting power of the earth, when made to act as the vehicle of the return current. Setting all theory aside, it is an unquestionable fact that if a telegraphic communication be made, suppose from London to Brighton, by means of a wire going thither, passing through a galvanometer, and then returning, the strength of the current shown by the galvanometer at Brighton will be almost exactly doubled if, instead of the return wire, we establish a good communication between the ends of the conducting wire and the mass of the earth at Brighton and London. The whole resistance of the return wire is at once dispensed with. The fact was more than suspected by Steinheil in 1838, but, for some cause or other, it obtained little publicity; nor does the author appear to have exerted himself to remove the reasonable prejudices with which so singular a paradox was naturally received. A most ingenious inventor, Mr. Bain, whose chemical telegraph we shall describe, independently discovered the principle, and proclaimed its application somewhat later; and in 1843 perhaps the first entirely convincing experiments were made by M. Matteucci, at Pisa. From this time the double wire required to move the needle telegraph was reduced to a single one. The apparent paradox is now known to be a consequence of Ohm's law, for it can be shown mathematically that if a conductor be infinitely extended the resistance between any two points in it depends on the size of the electrodes, and not on the distance between them.

Meanwhile the needle telegraph had undergone some further modifications. William Fothergill Cooke, who had seen Schilling's apparatus in 1836 at Professor Munke's house in Heidelberg, copied it, and brought it to England. Intent on improving the apparatus, he joined Wheatstone, and together they constructed a needle apparatus with four, and another with five, needles. The latter is represented in Fig. 359. The signs were given by the deviation of two needles at the same time. As may be seen from the drawing, twenty different signs could be given by the apparatus. The possibility of long distance telegraphy was much advanced about this time by the discovery of Henry—now known as the "law of ampere-turns" (*see* page 282)—that a weak current circulating many times round the core of an electro-magnet can produce the same magnetic effect as a strong current passing a few times round the same core.

Cooke and Wheatstone took out their first patent in 1837. A local



circuit was used for working the alarm, this being the first application of the so-called *relay*. By inventing the relay, Wheatstone made it possible to telegraph on long lines with much weaker currents. The

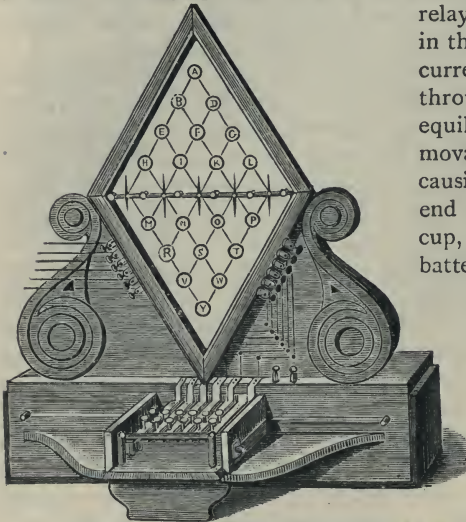

Fig. 359.—Cooke and Wheatstone's Five-Needle Telegraph.

relay was first used for the alarm only, in the form shown in Fig. 360. The current going through  $W$  passes through the coil  $M$ , disturbing the equilibrium of the magnetic needle, movable about the axis  $x y$ , and causing the lever  $a b$  to lower its end  $a$ , and to dip into the mercury cup, closing the circuit of the local battery  $B$  and the magnet  $E$ , and causing the pin  $s$  to strike the bell  $G$ .

The first experiment with the five-needle apparatus was made at the North-Western Station in London, with a wire of  $1\frac{1}{4}$  miles long. In 1840 the Great Western Company constructed a line 39 miles long, but did not extend the line any farther on account of the expense.

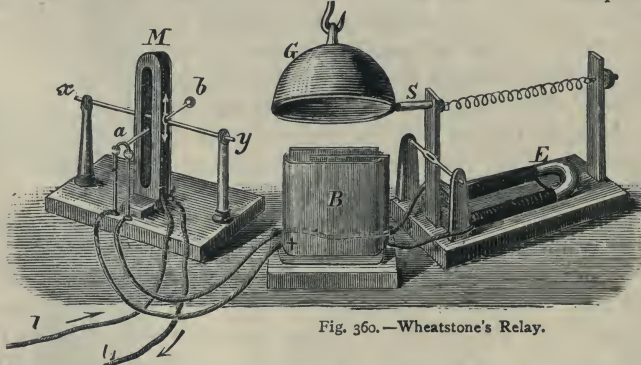

Fig. 360.—Wheatstone's Relay.

In 1839 Wheatstone replaced the five needles by a single needle or pointer moving over a dial by a "step-by-step" motion, so as to pass successively the letters of the alphabet engraved on the circumference of the dial. It is represented in Fig. 361. The sender here consists of a ratchet wheel  $k$ . The springs  $n n'$  are so arranged that when one spring makes contact with a tooth, the other spring will stand between two teeth. The negative pole of the battery is connected with the metal mass of the wheel, and the current flows from the positive pole



to the receiving station. The receiving apparatus consists of the two electro-magnets  $e$  and  $e_1$ , with the two armatures  $a$  and  $a'$  and the clockwork  $u$  whose pointer  $z$  moves over the different signs, the clockwork being put in motion by the weight  $G$ . The wire  $+l$  of the sending station leads to the clamp  $k_2$  of the receiving station; clamps  $k_1$  and  $k_2$  of the receiving station are connected with the springs  $n$  and  $n'$ ; when the wheel  $k$  is moved the battery current will alternately flow through the electro-magnets  $e$  and  $e_1$ , passing through the electro-magnet  $e$  when the spring  $n$  rests upon a tooth, as shown in the figure, and through the electro-magnet  $e_1$  when the spring  $n'$  comes to rest upon a tooth. Owing to the alternate excitation of the two electro-magnets, an alternate attraction

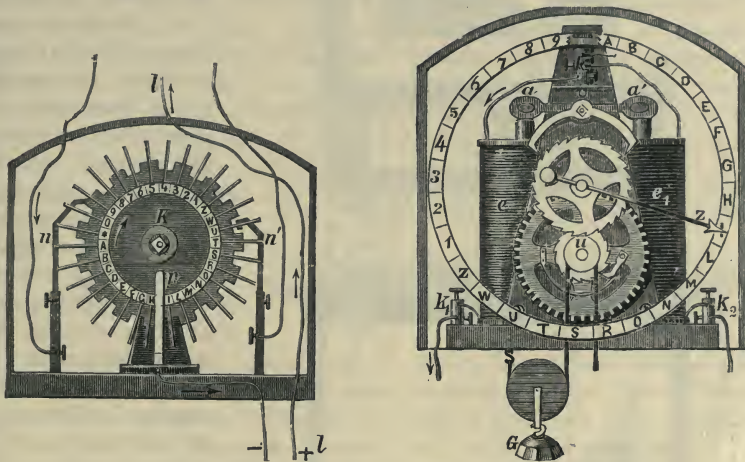

Fig. 361. — Wheatstone's Step-by-Step Telegraph.

of the armatures  $a$  and  $a'$  will take place, and, therefore, a swinging of the escapement  $s$ , which alternately releases a tooth of the wheel  $d$  first on the right and then on the left, thus allowing the pointer to move one place for each current sent.

Morse's contributions to telegraphic science in its early days are particularly interesting. A painter by profession, he did not take up the subject which has made his name world-famous until late in life, being attracted thereto by hints received from others. In 1837 he constructed an apparatus which, though very different in appearance from the now well-known Morse receiver or ink-writer, contains the germ of that instrument. It was further associated with, and rendered still more interesting by the use of, an automatic transmitter, the forerunner of the beautiful transmitters which are the pride of modern telegraphy.

This first apparatus of Morse's transmitted signs by combinations

of two simple motions, nine signs being used to represent the figures 1—9. Fig. 362 represents Morse's apparatus for the transmission of these nine numbers. The frame *c c* is vertically fastened upon a table, and carries a complex pendulum *o B* and the electro-magnet *E*. Upon the pendulum, which bears a pencil at the lower end, is fastened the

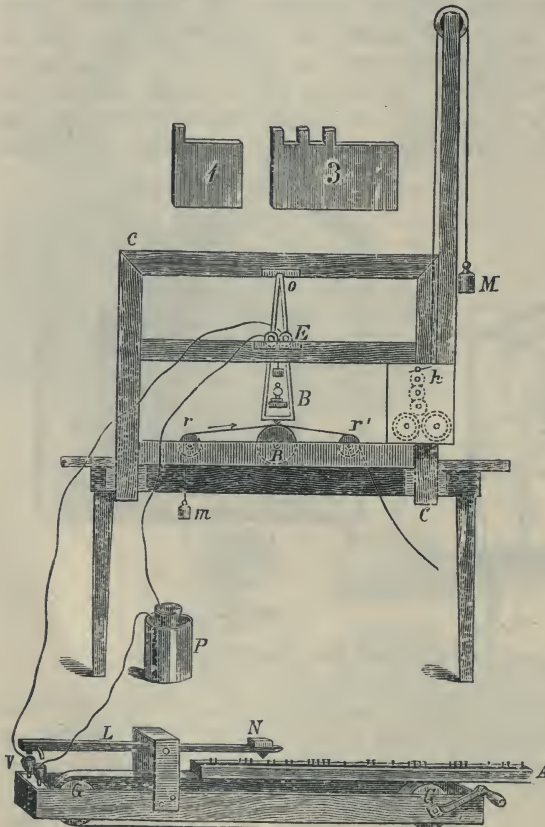

Fig. 362.—Morse's First Telegraph.

armature of the electro-magnet ; a paper strip passes over the roller *R* underneath the pencil, and is kept in motion by means of the clock-work *h* and the rollers *r r'*. When the pendulum is in its central position the pencil traces lines upon the paper that are parallel in direction to the length of the strip ; when the armature is attracted a slanting line (see Fig. 363) is traced by the pencil, and another slanting line is traced when the magnet lets the armature go, and the pendulum returns to its original position. By alternate magnetisation and demagnetisation **V**-shaped lines are formed. One **V** indicates the figure 1 ; two **V**'s the figure 2 ; and so on. These deflections of the pencil are produced in the following manner :

The lever *L* of the sender has the weight *N* placed at one end, and under this a pin ; at the other end a bent wire is arranged, which, when dipping into the mercury cups *v*, connects them with each other, and by doing so closes the circuit of the battery *P* and electro-magnet *E*. The types are placed in the wooden frame *A*. When *A* is made to move under the lever *N*, the lever will close the circuit as often as the edges of the lead types raise the end *N* of the lever.

The pencil at B will, therefore, make the corresponding signs on the paper strip. About the time when this apparatus was constructed, Morse made the acquaintance of Alfred Bail, who aided him greatly, and afterwards became one of his partners. The experiment succeeded for the first time on the 4th September, 1837. The signs obtained were those shown in Fig. 363, which correspond to the numbers 215, 36, 2, 58, 112, 04, 01837, which, according to the telegraphic dictionary, gave the words "Successful attempt with telegraph, September 4th, 1837." Morse's apparatus became known to Francis O. T. Smith, a member of Congress, and through his aid Morse was enabled to make a journey to London and Paris, which, however, proved fruitless as regards the finding of means to give effect to his invention. When he returned to New York (1839) Morse again took to painting, and afterwards to daguerreotyping, in order to maintain himself. In 1843 Congress voted the sum of 30,000 dollars for the construction of a trial line, and, as a consequence of this grant, the first line in America, 40 miles long, was tried for the first time in 1844, between Washington and Baltimore.

Morse's apparatus had, meanwhile, undergone many modifications so that by this date it closely resembled the form now usually employed. From that period the Morse

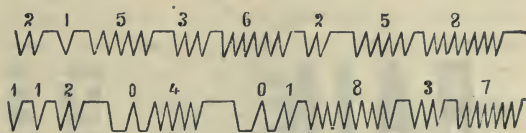

Fig. 363.—Morse's First Telegraphic Writing.

apparatus had a large demand, and in a very short time became widely if not generally used. Morse became electrician of the New York and Newfoundland Telegraph Company, and also of the New York, Newfoundland, and London Telegraph Company, and about the same time he was further appointed Professor of Natural History of Yale College, New Haven. In 1857 he received a present from ten European States of 400,000 francs, as an acknowledgment of his international services. Two monuments were erected to him in New York—one in 1871, the other in 1872, the year of his death.

The Morse instrument, which has been greatly improved in Europe, is equalled in usefulness by Hughes' printing instrument. This and the Morse apparatus were declared by one of the early International Telegraph Congresses to be the only exclusively reliable instruments for the international telegraph service. The first printing telegraph instrument, however, was constructed by the American, Bail, in 1837. Bain followed in 1840, and Wheatstone in 1841.

David Edwin Hughes was born in London in 1831, but emigrated in 1838 with his father to Virginia, where he was appointed Professor of Music at the High School, Barnstow. Here he studied natural science with such success that after some time the professorship was offered to



him. He devoted his time for some years to the construction of a type-printing telegraph apparatus, which he completed in 1853. A society in New York was formed, which undertook the introduction of the printing apparatus in America, whilst Hughes himself went to Europe for the purpose of making his instrument known. He met with no success in England, but was able to introduce the instrument into France, whence it very soon reached other countries.

The chemical telegraph, which had been first constructed by Sömmering, was so much improved in the course of a few years that it was of practical use to Bain in 1842. The principle consists in causing the end of the wire of the receiving station to move over a paper soaked in a solution that will be decomposed electrolytically when a current flows through the wire, and regulating the flow of current from the sending station, so that the decomposition and consequent colouring of the paper appear as written or printed letters. The word to be telegraphed is compounded of large simple metal letters, as shown in Fig. 364; these are connected with the positive pole of a battery, the negative pole of which is joined to earth. A metal plate, which

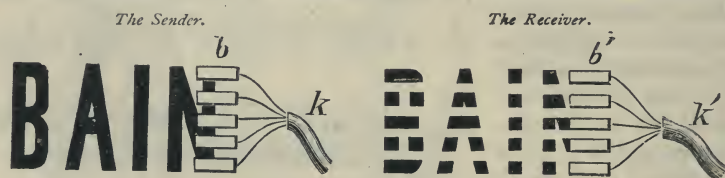

Fig. 364.—Bain's Chemical Telegraph.

is connected to earth, and upon which the paper containing the salt solution to be decomposed is laid, is arranged at the receiving station. The brush  $b$  at the sending station consists of five metal springs, and is connected by means of the cable  $k$   $k'$  with a similar brush  $b'$  at the receiving station, so that the first spring of  $b$  is connected with the first spring  $b'$ , and so on. If the brush  $b$  is moved over the metal letters, and the brush  $b'$  is moved at the same time and with the same velocity over the prepared paper on the metal plate, a circuit is closed as often as a spring of the brush  $b$  comes in contact with the metal letters, and consequently through the springs of the two brushes a current flows, which decomposes the salt solution and leaves a visible mark. The brushes  $b'$  form the anodes of little voltmeters, the electrolyte being a solution of potassium iodine in starch. The iodine is separated out by the current, and turns the starch blue or violet, in which colour the letters appear. The chemical telegraph has been modified by Stöhrer, Siemens, Gintl, and others. The copying telegraph by Bakewell and Bonelli, as well as the pantelegraph by Caselli (1856), may be classed among these.

After it had been found out that for ordinary telegraphic work one wire sufficed, attempts were made to utilise this one wire still further, thus leading to the invention of duplex telegraphy and multiplex telegraphy.

We owe the invention of the duplex system and the first practical experiments concerning it to Professor F. A. Petrina and to the director of the Austrian Telegraph Service, William Gintl (born 1804, died 1883). An apparatus constructed by Gintl was used in these experiments, because the Morse apparatus offered difficulties. In 1854, Frischen in Hanover, and Siemens, independently of each other, invented duplex methods. Maron described a method based on the principle of Wheatstone's bridge in 1863. A number of other proposals were made, to which no attention was paid until the American, Stearns, published a description of his duplex apparatus. By a duplex method of sending on telegraphic lines is meant the transmission of telegraphic signs in opposite directions simultaneously along one and the same wire. In quadruplex telegraphy two messages can be sent simultaneously in each direction along the same wire. Multiplex telegraphy has for its object the sending of several messages in one direction along the same wire and at the same time. If, for instance, with a single system, eight signs can be given in one second, by eight currents passing during that time through the leads; with a multiplex arrangement, in one second one hundred and more currents may be sent through the leads, which proves that the wire is only partly utilised when worked with the single current system. Newton described a method for the better utilisation of the wires as early as 1851, and Rouvier, Hughes, and others followed Newton's plan more or less closely. Duplex systems for Morse writing and multiplex systems for the Hughes apparatus have been devised by various inventors.

**Cable Telegraphy.**—Before we close our short sketch of the historical development of telegraphy, we may make a few remarks regarding the development of cable telegraphy. As early as 1774, when it was proposed to employ frictional electricity for telegraphical purposes, Le Sage, in Geneva, suggested the construction of a conducting cable; for this purpose glazed earthenware tubes were to be furnished with partitions of the same material, having holes through which the wires were to be taken. The telegraph apparatus consisted of double pith ball pendulums for each letter. In 1809 Sömmering covered the wire with a solution of caoutchouc, in order to convey it unhurt through water. In 1812 Schilling succeeded in exploding powder-mines by means of insulated wires which led across the Neva. Shortly before his death he made preparations to connect Cronstadt with Peterhof, by means of a cable intended to be sunk in the Gulf of Finland. In 1839 Sir William O'Shaughnessey Brooke, in Bengal, used a circuit 21 miles long, 7,000 feet of which consisted of a cable sunk in a river, and to him therefore belongs the credit of first actually transmitting telegraphic signals under water; his cable was insulated with pitch and tarred hemp. Jacobi, in St. Petersburg, in 1842, used a specially prepared wire, which was enclosed in glass-tubing, and then embedded in fine sand. With the introduction of gutta-percha, in 1843, a new era commenced for the construction of cables. Siemens used gutta-percha insulation for the first trial line. The new insulating material

seemed to do good service, and Prussia, Austria, and Russia at once used it for their underground leads; the insulation of the leads, however, went from bad to worse, so that the Prussian Telegraph Direction in 1852 was forced to discontinue using it. In 1840 Wheatstone proposed to connect France with England by means of a cable. In 1842 Morse made successful experiments in the haven of New York, and also warmly advocated the cable connection of America with Europe. In 1845 Ezra Cornell succeeded in connecting Fort Lee with New York (a distance of twelve English miles), by means of a cable which was laid in the Hudson; this cable did good service until 1846, when it was destroyed by the ice. In 1850, Dover and Cape Grisnez were connected by means of a cable, which lost its insulation the day after it had been laid by its friction against the rocks. The cable laid in 1857 by the Submarine Telegraph Company, between Dover and Calais, was protected by a cover of iron wire, and remained in use until 1875. The first attempts to connect England with Ireland were made in 1852. After failing twice, a cable was laid between Cagliari and Bona in 1860.

**The Atlantic Cable.**—Cyrus Field had meanwhile established a company

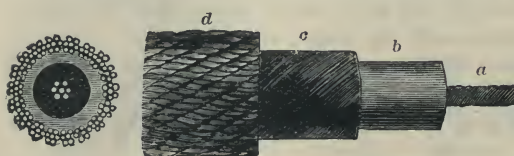

Fig. 365.—The First Atlantic Cable.

in America (in 1854), which had obtained the right of landing cables in Newfoundland for fifty years. Soundings were made in 1856 between Ireland and Newfoundland, showing a maximum

depth of 14,400 feet. Having succeeded, after several attempts, in laying a cable between Nova Scotia and Newfoundland, Field founded the Atlantic Telegraph Company in England, which decided to make use of a cable such as that shown in Fig. 365. Each of the seven copper wires in the centre had a diameter of 0.03 inch, and was covered by three layers of gutta-percha; these were enclosed in a covering of tarred jute, and the whole was covered by eighteen cables, each consisting of seven iron wires. The length of the whole cable was 2,480 miles, and was carried by the two ships *Agamemnon* and *Niagara*. The distance between the two stations on the coasts was 1,640 miles. The laying of the cable commenced on the 7th of August, 1857, at Valentia (Ireland); on the third day the cable broke at a depth of 12,000 feet, and the expedition had to return. A second expedition was sent in 1858; the two ships met each other half-way; the ends of the cable were joined, and the lowering of it commenced in both directions; 92 miles were thus lowered, when a fault in the cable was discovered. It had, therefore, to be brought on board again, and was broken during the process. After it, had been repaired, and when 295 miles had been already laid, another fault was discovered which caused another breakage; this time it was impossible to repair it, and the expedition



was again unsuccessful, and had to return. In spite of the repeated failures, two ships were again sent out in the same year, and this time one end of the cable was landed in Ireland, and the other at Newfoundland. The length of the sunk cable was 2,326 miles. Field's first telegram was sent on the 7th of August, from America to Ireland. The insulation of the cable, however, became more defective every day, and failed altogether on the 1st of September. From the experience obtained, it was concluded that it was possible to lay a trans-Atlantic cable, and the company, after consulting a number of professional men, again set to work. Of the samples sent in by the different makers, that of the firm of Glass, Elliott and Company was considered likely to answer the purpose best, and an order was given for 2,650 miles. Fig. 366 shows the different parts of the cable, viz. a copper strand of seven wires, a gutta-percha envelope consisting of four layers, a cover of tarred hemp, and an outer coating of iron wires covered with hemp. The *Great Eastern* was employed in laying this cable. This ship, which was 692 feet long, 82 feet broad, and 52.5 feet in depth, carried a crew of 500 men, of whom 120 were electricians and engineers, 179 mechanics and stokers, and 115 sailors. The management of all affairs relating to the laying of the cable was entrusted to Canning. The coast cable was laid on the 21st of July, and the end of it was connected with the Atlantic cable on the 23rd. After 823 miles of cable had been laid, a fault was discovered, an iron wire was found stuck right across the cable, and Canning considered the mischief to have been done with a malevolent purpose. On the 2nd of August, 1,364 miles of cable were sunk, when another fault was discovered. While the cable was being repaired it broke, and attempts to recover it at the time were all unsuccessful; in consequence of this the *Great Eastern* had to return without having completed the task.

A new company, the Anglo-American Telegraph Company, was formed in 1866, and at once entrusted Messrs. Glass, Elliott and Company with the construction of a new cable of 1,860 miles. Different arrangements were made for the outer envelope of the cable, and the *Great Eastern* was once more equipped to give effect to the experiments which had just been made. The new expedition was not only to lay a new cable, but also to take up the end of the old one, and join it to a new piece, and thus obtain a second telegraph line. The sinking again commenced in Ireland on the 13th of July,

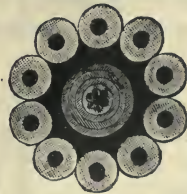
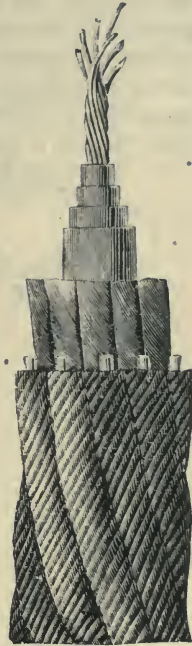

Fig. 366.—The Second Atlantic Cable.

1866, and it was finished on the 27th. On the 4th of August, 1866, the Trans-Atlantic Telegraph Line was declared open.

Since then other Atlantic cables have been laid, and the great ocean is now (1909) spanned by no fewer than sixteen such links of communication, the last of which was successfully deposited in 1905. Steamers specially constructed are now employed, far less expensive than the *Great Eastern*, and the laying of the last cable occupied no more than twelve days, without the slightest hitch or interruption from beginning to end. The later cables do not differ in general construction from those already described; but improvements in details have produced greater strength, and better insulation and conductivity. There is now no practical limit to the length of cable which could be laid if required, beyond the contingencies of severe weather, while

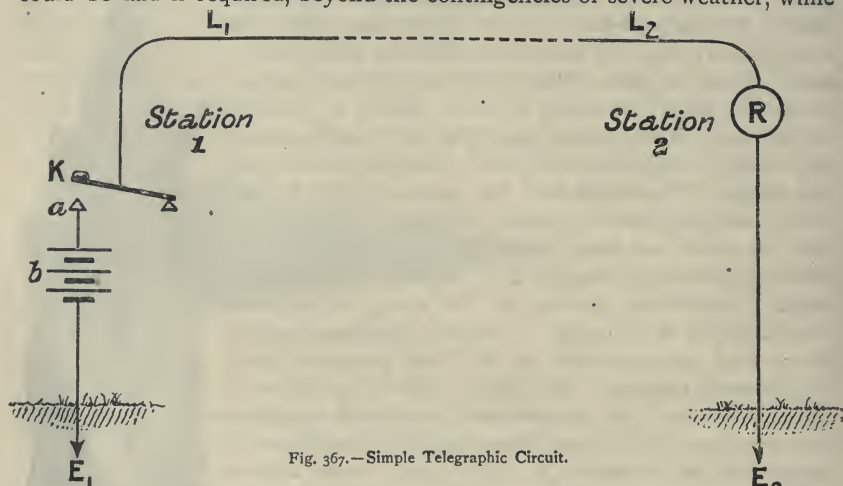

Fig. 367.—Simple Telegraphic Circuit.

the art of picking up and repairing cables which have broken down in working has been developed to a high state of perfection.

## II.—SIMPLE TELEGRAPHIC WORKING.

The fundamental principle underlying electric telegraphy is very simple, being none other than the law that in a simple closed circuit the current is the same in every part of the circuit. With a simple switch or key it is therefore possible, by breaking the circuit at any point, to interrupt the current, and by closing the circuit again to cause the current to flow once more. The effects of the current, whether magnetic, chemical, or thermal, produced in any part of the circuit can therefore be interrupted and renewed at pleasure from any other part, and since these two parts may be hundreds of miles or more asunder, the possibility of two persons communicating through a pre-arranged code of signals is established.

The simplest form of telegraphic circuit is therefore that shown in Fig. 367.

Two stations **1** and **2** at a distance from one another are connected by a conducting wire  $L_1, L_2$ . At **1** there is a key  $K$  which rests ordinarily in the position shown in the figure, whilst at **2** there is some kind of receiving instrument  $R$  (e.g. a galvanometer), which is able to indicate when a current traverses the circuit and when not. When the key  $K$  is depressed it rests on the contact  $a$ , which is joined to a terminal of the battery  $b$ , the other terminal of the battery being connected to an earth plate  $E_1$ ; one terminal of  $R$  is connected to another earth plate  $E_2$ . Consequently when  $K$  is depressed a current flows from  $b$  through the line  $L_1, L_2$  and the receiving instrument  $R$ ,

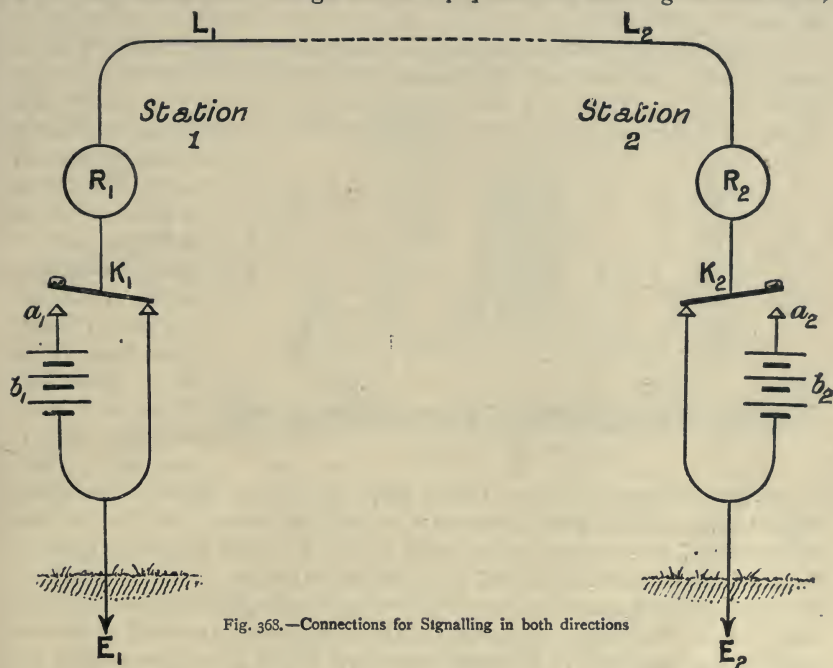

Fig. 368.—Connections for Signalling in both directions

returning to the battery through  $E_2$ , the earth and  $E_1$ . The receiver  $R$  shows that the current is passing, and thus a signal is received.

The arrangement in Fig. 367 only allows station **1** to signal to station **2**, the latter having no means of replying. This difficulty is met in a simple manner by the arrangement depicted diagrammatically in Fig. 368, where the back contacts of the keys  $K_1$  and  $K_2$  are shown connected to the respective earth plates  $E_1$  and  $E_2$ , whilst the front contacts are connected to the working batteries  $b_1$  and  $b_2$ . There are receiving instruments at each station, and the method of working is obvious.

**Relays.**—As the distance between the two stations increases, so does the length, and therefore the resistance, of the line connecting them, unless the



cross-sectional area of the wire be proportionally increased, which is not possible in practice. To obtain the same current through the increased resistance requires an increase of E. M. F. in the circuit, which if carried far becomes objectionable not only because of increased cost if batteries are used, but also because of increased difficulties of insulation and for other reasons. The difficulty can be partly overcome by utilising Henry's discovery and winding the receiving instruments with finer wire so as to obtain the same ampère-turns with a smaller current. There is, however, obviously a limit to the application of this device, as in itself it tends to increase the resistance of the circuit still further.

Practically an indefinite increase of distance can be obtained wherever the line can be split into separate sections by using the principle of the relay invented (*see* page 392) for a different purpose, in 1837, by Wheatstone and Cooke. The relay may be briefly described as a *delicate form of electro-magnet*

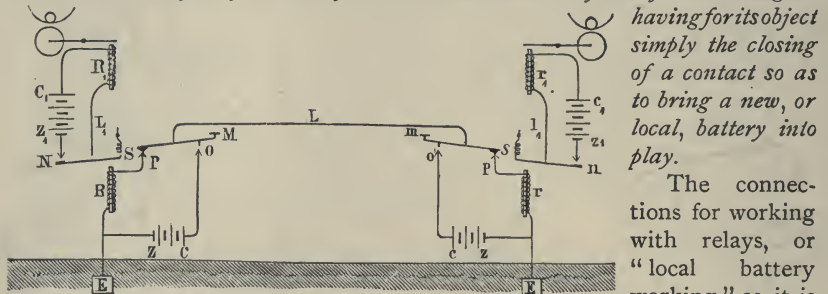

Fig. 369.—Relay Connections.

*having for its object simply the closing of a contact so as to bring a new, or local, battery into play.*

The connections for working with relays, or "local battery working" as it is generally called,

are shown diagrammatically in Fig. 369. M and m indicate the Morse signalling keys, o o sending contacts, P p receiving contacts, R r the magnets of the relays, N n contact levers of the relays, R<sub>1</sub> r<sub>1</sub> the electro-magnets of the receiving apparatus, C z and c z sending batteries, C<sub>1</sub> z<sub>1</sub> and c<sub>1</sub> z<sub>1</sub> local batteries of both stations; s and s' are two springs which pull off the armatures of the relays R r and open the contacts N n as soon as current ceases in the line circuit. When no signalling is going on, the stations are connected by means of the line L and earth E E. When one station wishes to send a telegram to another, the following circuit can be closed by pressing down the key M upon o, so as to close the contact at o, and at the same time to open the contact at P. From the pole c of the sending battery, the current flows over o M through the line into the second station, thence it proceeds over m p into the electro-magnet r of the relay, and so to earth. The other battery-pole z of the sending station is also connected with earth. The electro-magnet r attracts its armature, contact is made at n, and the local circuit of the receiving station closed. A current entirely distinct from that received from the distant station now flows from one pole c<sub>1</sub> of the local battery into the electro-magnet r<sub>1</sub> of the receiving instrument through the line L<sub>1</sub>

over  $n$ , hence back to the second pole  $z_2$  of the local battery. The magnet of the receiving instrument attracts its armature, presses the pencil or printing wheel against the strip of paper, and reproduces the signal given by the key  $m$ .

*Non-polarised Relays.*—A great many different relays have been constructed; they may all, however, be grouped in two classes, namely, polarised and non-polarised relays. The former are more frequently used in England than the latter, and are called polarised because their armatures are magnetised either by means of permanent magnets near them, or by being themselves the poles of permanent magnets. One of the oldest non-polarised American relays is shown in Fig. 370. The brass plate  $aa$  is fastened upon the block  $AA$ , and carries the electro-magnets  $E E_1$ , the iron cores of which are connected with each other by means of the

iron yoke  $m$ . The bearings for the lever  $c$ , with its armature  $k$ , are attached to the pillar  $b$ . The motion of this lever is limited by the contact screws  $e f$ , fastened to the support  $d$ , which is insulated and fixed upon  $aa$ . The spiral spring  $s$ , the tension of which can be

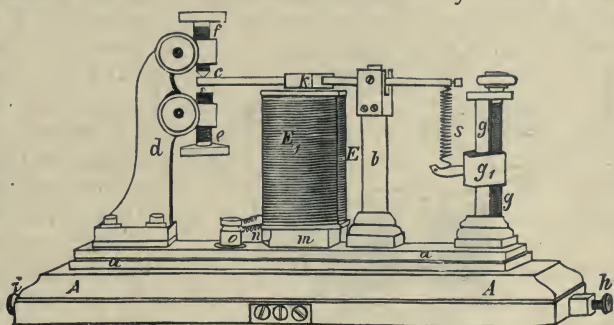

Fig. 370.—American Non-polarised Relay.

regulated by means of the guiding piece  $g_1$  moving upon  $g g$ , drags  $k$  off the magnet cores when the current in the coils ceases. The support  $g g$  is connected with the binding screw  $h$ ; and screw  $e$ , which has a platinum contact pin at the upper end towards the lever  $c$ , is connected with the second binding screw  $i$ . The screw  $c$  is tipped with ivory, and therefore does not close any circuit when  $c$  rests against it.

The local circuit, which contains the local battery and the receiving apparatus, is connected to  $i$  and  $h$ . When even a very weak line current passes through the coils of the electro-magnet  $E E_1$ , which are wound with many turns of fine wire, it will cause it to attract  $k$ , and contact will be made between  $c$  and  $e$ . The current from the local battery reaches the support  $g$  through  $h$ , flows into the lever  $c$ , and screw  $e c$ , from there through  $d$  and  $i$ , and so into the receiving instrument. As every line current which reaches the relay acts in the way described above, it is evident that the relay sends a powerful local current instead of the weak line current into the receiving apparatus, and thus produces a distinct signal, whether the sending station be at a short or long distance.

*Siemens' Polarised Relay.*—An excellent form of polarised relay which

has been in use for many years, and is still largely used, is shown in Fig. 371. Down the side of the instrument, and bent underneath it, passes the hard steel permanent magnet  $s\ N$ , the upper or  $s$  end of which is cut away so that a soft iron lever can be pivoted in the slit at  $a$ . Upon the horizontal arm of the permanent magnet, which is bent at right angles, the limbs of the electro-magnet  $E\ E$  are placed, and connected by means of the yoke  $m$ . The cores, which pass through the plate  $A$ , have movable pole-pieces  $b\ b$ , which are kept in any desired position by the screws  $c\ c$ . The armature is the soft-iron lever  $z$ , pivoted at  $a$  between the south poles  $s\ s$  of the permanent magnet. The

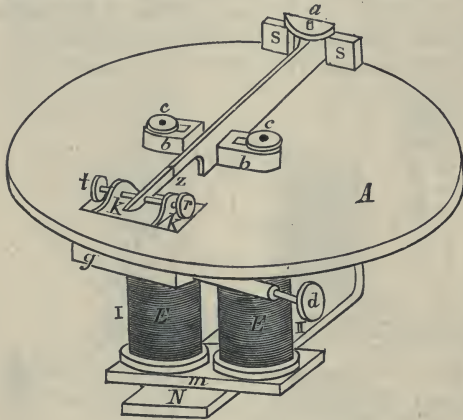

Fig. 371.—Siemens' Polarised Relay.

play of the lever is horizontal from side to side, and is limited by the contact screws  $r\ t$ , one of which,  $t$ , ends in an agate point, and the other,  $r$ , is insulated by means of the vulcanite pieces  $k\ k$ . Both contacts can be moved simultaneously by means of the screw  $d$ . The electro-magnet  $E\ E$  being upon the north pole  $N$  of the permanent magnet, the poles  $b\ b$  have north magnetism, whilst  $z$  has south magnetism. The one or the other pole may be made to prevail by adjusting the lever. The action is therefore

as follows: The lines of force from the pole  $N$  of the permanent magnet  $N\ S$  pass up through the bar  $m$  and the cores in contact with it, and therefore cause north polarity in the ends of the cores remote from it. The lines pass from the cores into the lever  $z$  and along it to the poles  $s\ s$  of the permanent magnet, inducing north polarity in the end  $a$  of the lever  $a\ z$ , and south polarity in the end which moves between the poles  $b\ b$ . The continuation of this lever beyond  $z$  is a non-magnetic metal, which is not affected by the lines of force. When the lever  $a\ z$  is equally attracted by both poles at  $b$  and  $b$ , it remains equidistant from them, but when one pole is screwed a little nearer than the other it draws the lever to it. When the relay is at rest the latter is its position, the lever then touching the agate point. When the working current from the line enters the coils of the electro-magnets  $E\ E$  the poles are changed, that at the end  $b$  of  $II$  being strengthened as a north pole, and that at the end  $b$  of  $I$  being either weakened or reversed to a south pole. Hence the lever is drawn from the agate point to the opposite metal point  $r$ , and remains on the contact  $r$  as long as the line current flows, but falls away when this current ceases. The contact closes the local circuit which works the receiving instrument.



The resistance wound on the electro-magnet E E depends on the working conditions, that is, on the resistance of the line upon which the relay is to be placed.

**Signals.**—An important question to be considered in devising a system of telegraphy is the nature of the signal to be sent. Two general courses are available. We may make use of the ordinary alphabetical characters, and arrange these in convenient positions on the receiving instrument, which must be constructed so as to indicate the particular letter to which attention is to be drawn. Sömmering's electrolytic telegraph and Wheatstone's five-needle and "step-by-step" instruments already described are examples of this method, which as hitherto applied is not conducive to rapid signalling.

On the other hand, we may entirely discard the ordinary symbols for the letters of the alphabet, and construct a new set of symbols specially adapted for telegraphic purposes. It is found that two distinct signals when properly combined can be made to represent the twenty-six letters of the English alphabet, no particular combination consisting of more than four signals. The requirement of two distinctive signals can be met by the right and left movements of an ordinary galvanometer needle, which can be converted into audible signals by causing the needle to strike differently toned bells or resonators on either side. They can also be met by instruments which can only make a mark in a definite position on a travelling ribbon or band, the necessary distinction being obtained by making the marks either long or short, or, as they are usually called, either "dashes" or "dots." The important point is that the method can be applied whenever two distinctive and easily recognised signals can be produced. Hence its wide extension to non-electrical telegraphy, such as flag-signalling, heliography, etc.

The combination of the two signals now usually adopted is that first put forward by Morse, and known as the "Morse Alphabet." In constructing this alphabet Morse first analysed the frequency with which the various letters recur in ordinary English prose composition. He then allotted the shortest signals and combinations in proper order to the letters occurring most frequently. The result is an alphabet the use of which, it is obvious, must tend towards the greatest possible speed in the transmission of the messages.

Using a dot and a dash to indicate the two distinctive signals, the Morse alphabet will appear thus :—

a . -	l . - . .	v . . . -	6 - . . . .
b - . . .	m - -	w . - -	7 - - . . .
c - . - .	n - .	x - . . -	8 - - - . . .
d - . .	o - - - -	y - - - -	9 - - - - .
e .	p . - - .	z - - . .	0 - - - - -
f . . - .	q - - - . -	1 . - - - - -	. . . . .
g - - .	r . . .	2 . . - - -	? . . - - . .
h . . . .	s . . .	3 . . . - -	: . - - - . .
i . .	t -	4 . . . . -	; - - - . . .
k - . -	u . . -	5 . . . . .	! - - - . . -

The letters thus formed of dots and dashes are separated by variable spaces as they are called. There are three kinds of spaces: the space separating the elements of a letter, that separating the letters of a word, and that separating the words themselves. These durations of break or silence are as necessary as the durations of contact or sound. When we look upon the Morse alphabet as applicable to the various instruments described, including the sounder, we may define it as a method by which time is divided into multiples of an arbitrary standard or unit, viz. the dot.

1. A dash is equal to three dots.
2. The space between the elements of a letter is equal to one dot.
3. The space between the letters of a word is equal to three dots.
4. The space between two words is equal to six dots.

The following arrangement of the signs will assist the memory to retain them. The foundations of the alphabet are the dot (.) representing the letter e, and the dash (—) representing the letter t. This gives us the group e and t of the first order. Placing a dot before each of these elementary characters, we have

..	i	. —	a
----	---	-----	---

Placing a dash before each elementary signal we have

- .	n	- -	m
-----	---	-----	---

These give us the group of the second order, i, a; and n, m

Now affixing to each of the above four signals first a dot and then a dash, we have

... .	s	- . . .	d
. . . -	u	- . . -	k
. - . .	r	- - . .	g
. - - .	w	- - - -	o

These constitute the group of the third order, s, u, r, w; and d, k, g, o

Pursuing the same plan with these eight characters, we have

....	h	- . . .	b
. . . -	v	- . . -	x
. . . .	f	- . . .	c
. . . -	ü (German)	- . . -	y
. - . .	l	- - . .	z
. - - .	ä (German)	- - . -	q
. - - .	p	- - - .	ö (German)
. - - -	j	- - - -	ch

These constitute the group of the fourth order, h, v, f, ü, l, ä, p, j; and b, x, c, y, z, q, ö, ch.

There is also the French accented *é* (••—••), but with this exception no letter exceeds four signals.

Combinations of five signals are employed to indicate the ordinary numbers, according to the following code:—

1	•••••	6	—••••
2	••••—	7	—•••••
3	•••—••	8	—••••••
4	••••—•	9	—•••••••
5	••••••	0	—••••••••

The ordinary marks of punctuation are represented by combinations of six signals, thus:—

(,)	•••••••	(?)	••••••••
(;)	—••••••	(!)	—••••••••
(:)	—••••••••	(-)	—•••••••••
(.)	•••••••••	(')	••••••••••
	(“ ”)		••••••••••

Thus a combination of *four* signals or less indicates a letter of the alphabet (except in the case of *é*, which has five), a combination of five signals indicates a number, and lastly, a combination of six signals indicates some sign of punctuation.

### III.—INSTRUMENTS.

We propose to give here a brief description of some of the instruments most widely used in the early days of telegraphy, which well illustrate the principles employed, leaving the more modern instruments which represent the more recent applications of these principles to the later section.

**Transmitters.**—These may be divided into hand and automatic transmitters; the latter belong to the more recent section of the subject and will not be dealt with here, though we may again point out that Morse used (*see* page 394) an automatic transmitter in one of his earliest attempts.

The hand transmitters again sub-divide according to the character of the currents that have to be transmitted in order to work the receiving instruments. In signalling with the Morse code we may either have to use direct currents, that is, currents always in the same direction but of different durations, or we may require reverse currents, that is, currents alternately in opposite directions, to produce, for instance, the right and left motions of a galvanometer or galvanoscope needle. Lastly, for dial and step-by-step instruments we require a transmitter, often of a complicated character, specially adapted to the particular receiving instrument employed.

The simplest of all transmitters is that used for direct currents with the Morse code, and known as the “Morse Key.” An early form is



shown in Fig. 372. Three brass bars *N M* and *V* are fastened upon a basement block of wood *A*; *M* has the two brass cheeks *D D'* arranged upon it, as chairs or bearings for the support of the axle *B*. The lever *b b'* moves about this axle, being moved in the one direction by the hand of the operator pressing on the knob *G*, and when released returning in

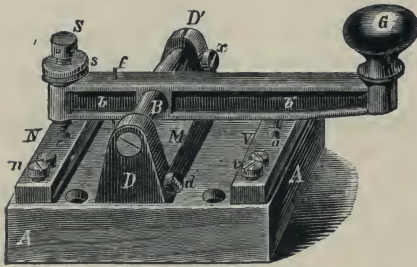

Fig. 372.—The Morse Key.

consequence of the tension of a spring *f*; steel or platinum contacts *c a* are screwed into the bars *N* and *V*, and the corresponding contact-pins pass through the lever *b b'*. One end of the spiral spring *f* is attached to the lever at *b*, and the second end is fastened to the bar *M*. This spring serves to hold the lever down upon the contact *c*, which is regulated by the screws *s s*. The

line-wire is connected with the middle plate *M*, the receiving apparatus with *N*, and the sending apparatus, including the home battery, with *V*. Hence the key is always set ready to receive a message, but must be pressed down to send one. Such a key is represented diagrammatically at *K*, *K*<sub>1</sub> and *K*<sub>2</sub> of Figs. 367 and 368, and at *M* and *m* of Fig. 369.

The electrical model of all *reversing keys* or commutators, as they are sometimes called, is illustrated under the name of the *tapper* in Fig. 373. It consists of two bars of brass or copper *z* and *c* connected with the battery and two metal springs *L* and *E*, one of which *L* is connected with the line, and the other *E* is put to "earth." The springs both pass under *z* and over *c*, and when not pressed on they both touch the bar *z*, but do not touch the bar *c*. One spring must be pressed down to make the circuit. When the finger is pressed upon the knob *N* of the spring *L* it connects *L* and *c*, and sends the current from the copper or positive pole of the battery to *L*, and from "earth" back to *z*, the zinc or negative pole. If the knob *P* on *E* is pressed down the current goes from copper to *E*, and from line back to *z*. To depress *N* causes the needle of an ordinary single-needle receiving instrument to swing to the left. To depress *P* causes the needle to swing to the right.

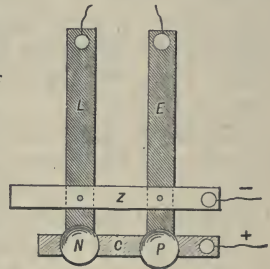

Fig. 373.—The Tapper.

Another, electrically similar, form of commutator often used on single-needle instruments, especially in railway signalling, is the drop-handle commutator seen below the needle in Fig. 376. In this commutator a motion of the handle to the left puts the copper of

the battery to line and the zinc to "earth," whilst a motion to the right reverses these connections. This is accomplished by splitting the cylinder moved by the handle into two parts, electrically insulated from one another, one of which is permanently connected to the positive pole of the battery and the other to the negative. By moving the handle suitable pins or projections on the cylinder are brought into contact with either line or "earth," as specified above.

The last species of transmitters in our classification, namely, those which are specially constructed to serve complicated forms of receiving instruments, will be best described in connection with the receiving instruments for which they are adapted.

**Receiving Instruments.**—Several classifications of these are possible; they may give either *visible* or *audible* signals, and the visible signals may be either permanent or transient, according as they are produced by *recording* or *non-recording* instruments.

*The Sounder or Bell.*—Undoubtedly the simplest form of receiving instrument is the simple sounder, which is only an electro-magnet with a movable armature. The form used by the British Post Office, and known as the P. O. Sounder, is shown in Fig. 374, in which M is an ordinary two-

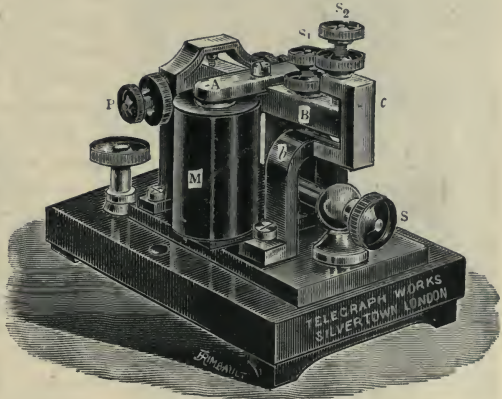

Fig. 374.—The P. O. Sounder.

limb electro-magnet, with its cores standing on an iron yoke-piece in the base of the instrument, and having its poles bridged by the iron armature A. This armature is carried by the heavy brass piece B, which is in the form of a bent lever pivoted on the ends of the screws P. The vertical arm of the lever is connected by a spiral spring, which passes between the magnet limbs, to the set screw S. There are two screws,  $s_1$  and  $s_2$ , limiting the play of the lever;  $s_1$  is carried by the lever itself, and is so set that when the armature is drawn down it is just held from actually touching the iron of the core by the screw  $s_1$  striking against the bridge  $b$ . The other screw,  $s_2$ , is carried by the rectangular fixed brass piece C attached to the bridge  $b$ , and is so set that when the current ceases to flow, the spring controlled by S pulls the armature and lever back through a sufficiently small distance to cause an audible sound as B strikes the end of  $s_2$ . Similarly, an audible sound is produced when the end of  $s_1$  strikes against  $b$ .

The time elapsing between the two sounds is short or long, the short corresponding to a swing to the left in the needle instrument, or to a dot in Morse's system, and a long interval to the swing to the right, or to the dash. The sounder has been introduced into America, and has there supplanted all other forms of apparatus. It is also almost universally employed in India. The key or transmitter required to work it is the simple Morse key already described.

The earliest form of acoustic instrument used in England was probably Bright's bell. In this instrument two bells of different tone are used, the hammer of one being actuated by currents in one direction, and that of the other by currents in the other direction. The sound of one bell corresponds to a dot, and that of the other bell to a dash. One of these bells is shown in Fig. 375, where the electro-magnet  $E$ , when energised by the current, attracts the armature  $A$  and causes the hammer  $B$  attached to it to strike the metal plate  $M$ , giving an audible sound.  $A$  and  $B$  move round the pivoted axle  $X$ , and  $A$  is ordinarily held off the magnet poles by the opposing spring  $S$ , which can be "set-up" by the screw to give any desired pull. The sending apparatus is the same as the tapper of the single needle, and relays and local currents are often needed. The instrument is, probably, the quickest non-recording instrument extant, but it is complicated in its construction and

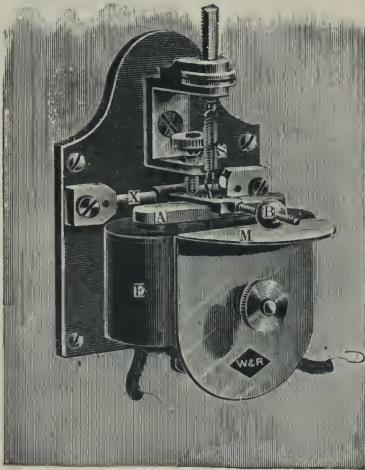

Fig 375.—The "Bell" form of Sounder.

difficult in its adjustment compared with the sounders. Other bells will be described under the head of special signalling apparatus.

*Single-needle instrument.*—Next in simplicity to the sounder is the single-needle instrument, which is nothing more than a vertical galvanoscope with a gravity control. An exterior view of an early form is given in Fig. 376. The needle seen on the front of the instrument is only an indicator fixed on the axis which carries the magnetic needle influenced by the current as in Fig. 310 (*see* page 346). A movement of the top end of this pointer to the left is equivalent to a dot in the Morse code, whilst a movement to the right stands for a dash. In many forms two ivory stops are fixed, one on either side, to limit the motion of the needle; and an expert clerk, used to his instrument, can often recognise the difference in the sound as the top end of the pointer strikes one or other stop, and thus can read



the message by ear instead of by eye. In a still later form the ivory stops have been replaced by little resonant metal cylinders, which give louder acoustic signals more easily distinguishable from one another.

*Morse Receivers.*—The widely-used Morse receivers, whether in the form of *embossers* or *ink-writers*, are simply sounders with recording arrangements attached. The earliest form was the embosser shown in Fig. 377. The electro-magnet  $\epsilon \epsilon$  consists of two cylindrical cores of very soft wrought iron, which are connected at their lower ends by an iron yoke, so that they form a

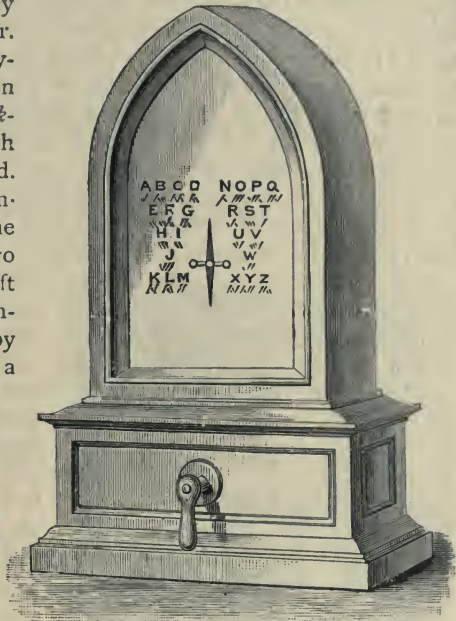

Fig 376.—Single-Needle Instrument.

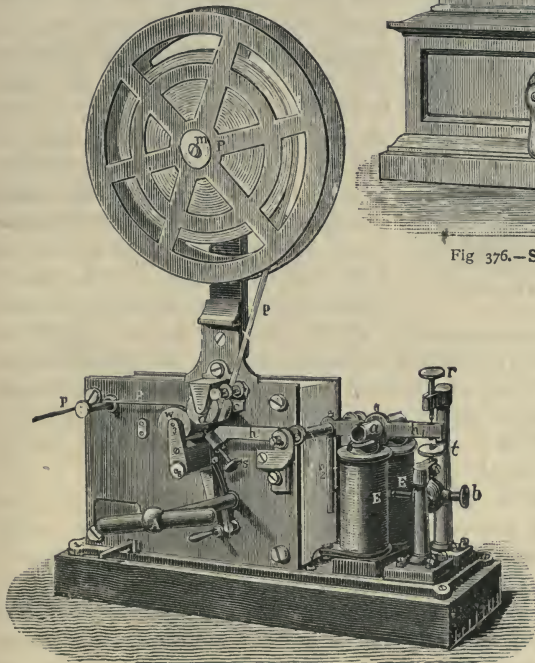

Fig. 377.—The Morse Embossing Instrument.

two-limb magnet. Both arms have a great number of turns of insulated copper wire wound round them, connected as explained at page 331. The armature  $a$  of the electro-magnet, and the style  $s$ , are fastened to the lever  $h$ , which can move about a horizontal axis. The lever is connected with a spiral spring, attached to a screw  $b$ , which when turned in the right direc-

tion increases or diminishes the tension of the spring, and therefore offers a greater or less resistance to the attraction of the armature by the magnet.

The play of the lever is limited by the adjustable contact-screws  $r$  and  $t$ . The printing arrangement by which the signals are impressed on the strip of paper drawn off the wheel may be better understood from Fig. 378. In both figures the various parts are indicated by the same letters. The end of the lever  $h$  is slit, and the style  $s$  is placed in the slit. This style is adjusted by means of the knob  $s_1$ , and ends in a blunt but glass-hard point, which serves the purpose of marking the paper. When the pencil is arranged in the right position, it is maintained in it by tightening the screw  $n$ ;  $d$  is the printing roller, which turns round the axle  $a_2$ , and has a groove at  $B$  in order to facilitate the marking by the style. The paper is held between the rollers  $d$  and  $w$ , the latter of which is rotated by clockwork contained in the metal box, the speed of which can be regulated. The roller  $d$  is pressed firmly but

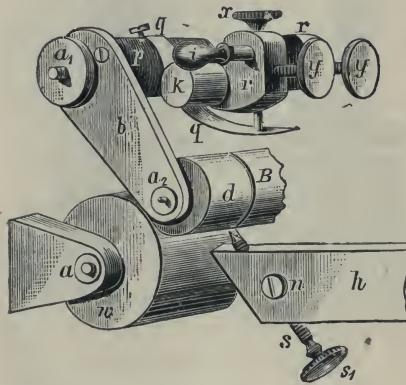

Fig. 378.—Details of the Morse Embosser.

is sent through the electro-magnet  $E E$ , Fig. 377, the latter attracts its armature, and the lever  $h$  moves the style up, causing an indentation to be made on the paper as long as the style  $s$  presses against it—that is, for as long as the current lasts. When the current lasts only a short time, a short line, technically called a dot, is produced; when the current lasts a longer time, a dash is produced.

The *ink-writer* is a development of the above with which the dots and dashes are written in ink instead of forming indentations on the paper. Although it has been in use for some time, it is essentially a modern instrument, and will be described in the next section of the book.

*Dial Instruments.*—For private telegraphic work where skilled signallers are not available and where speed is not of much consequence, it is essential that the ordinary alphabetical characters should be used both in the transmitter and the receiver. This led in the early days and before the development of telephony, which is still better adapted for use by unskilled correspondents, to the invention of numerous systems of “dial”

telegraph instruments fulfilling more or less perfectly the conditions named.

The widely-used A B C instruments of Wheatstone were amongst the earliest of these dial sets. They had the advantage that they dispensed with a battery and obtained the necessary currents by magneto-electric induction. As we have not yet described this method of generating electric currents, we select for description another system, that of Bréguet's, which, at the time referred to, was largely used in this country and on the Continent.

As usual in apparatus of this kind, the transmitting and receiving instruments in *Bréguet's dial telegraph* are distinct and different. The transmitting apparatus is shown in Fig. 379. It has a dial, round the face of which are placed the letters of the alphabet, and the sign +, which is used to divide words; and in another row are placed numerals, as far as 25. A small notch will be seen cut in the rim opposite each letter. A handle *m*

is pivoted to the centre, the arm having a slot cut in it, and this is turned round (in one uniform direction only, never backward) till the letter or figure required appears through the slot, a small pin on the under side catching in the notch, and keeping the position exact. If the letter is overshot the arm must not be moved back, but carried round again; hence the need of the slot and pin, not otherwise material. The removed part of the dial shows a

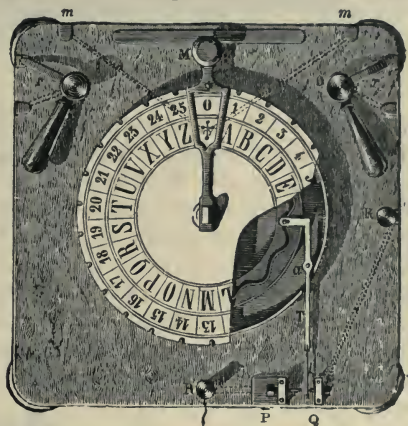

Fig. 379.—Bréguet's Transmitter.

wheel beneath which turns with the handle, and has cut in it a wave-shaped groove, having half the number of waves that there are letters, so providing either a crest or a hollow for each. A roller on the end of the bent lever *T* works in this groove, so that in turning the handle one revolution, the lower end of *T* is moved from side to side twenty-six times, or thirteen to-and-fro complete motions. At the bottom of the lever a platinum spring thus comes alternately into contact with the contact-screws *P* and *Q*; *P* goes to the line-wire, while the battery-wire goes to *m*, passing thence to the grooved wheel, and so to the lever *T*.

The receiving apparatus is shown in Figs. 380 to 382. Fig. 380 is the face, showing a small key-axle between the numbers 25 and 1 on the dial, by which the clockwork in the interior is wound up. Fig. 381 is a back view, showing interior parts, except that the magnet, which faces the dotted circles of the armature *A*, is removed for clearness. The clockwork causes the pointer to travel round the face rather quickly until stopped or regulated by the



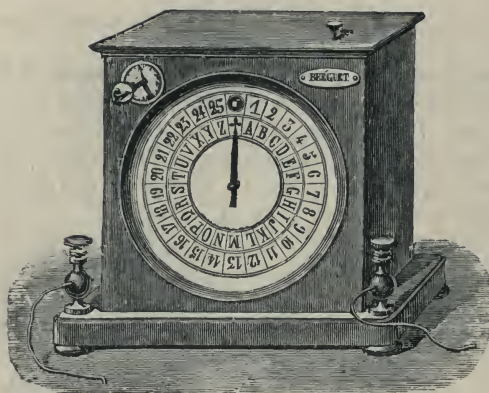

Fig. 380.—Bréguet's Receiving Instrument.

the axis of this wheel, so that in the same period it also moves forward the space of one letter. The armature *A* (Fig. 381) swings to and from the observer from suspending pivots fixed in the projecting supports *v v'*, and carries with it the arm *l*, having a horizontal pin *c* projecting from one end of it. A spiral spring *f* draws the armature back when the current does not pass through the coils of the horse-shoe electro-magnet, whose poles are opposite *A*. The armature, and with it the pin *c*, therefore swing backwards and forwards as the current

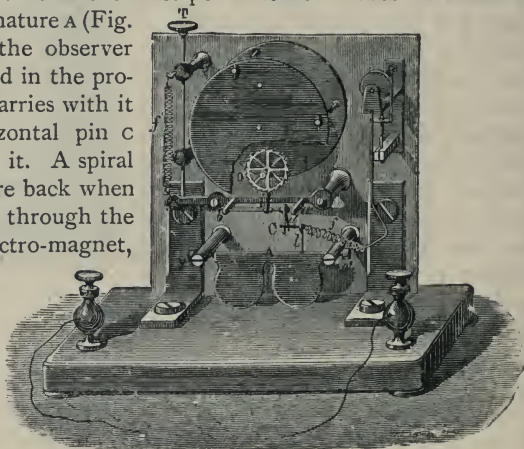

Fig. 381.—Construction of Bréguet's Receiver.

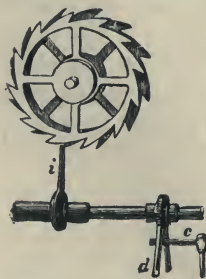

Fig. 382.—Escape-Wheel.

is made and broken; and in the enlarged view of the escape-wheel in Fig. 382. it will be seen how this motion of the pin *c* in the fork *d* works the escapement, thus causing the pointer to move round the dial one step for every "make" or "break" of the current.

The action of the two instruments can now be readily understood. It has been seen that a complete revolution of the pointer of the sending instrument makes and breaks the current thirteen times, or makes twenty-six changes; and these twenty-six changes also move round the

escape wheel *D*, a larger view of which is given in Fig. 382. It comprises two ordinary notched wheels mounted on one axis, so that the teeth alternate. The pallet *i* underneath, as it vibrates backwards and forwards, alternately catches the tooth of each wheel in succession, so that if there are thirteen teeth on each, every movement of the pallet enables the wheel to revolve one twenty-sixth of a revolution. The pointer is fixed to

pointer of the receiving instrument a complete revolution. Any lesser number of steps is similarly reproduced in the receiving instrument.

This instrument works in practice remarkably well. Occasionally the pointer will get wrong, owing to a mistake or interruption in the message; in that case the head of the rod  $\tau$  is depressed, liberating the escapement altogether until it has rotated back to the sign  $+$ , when all starts correctly again. The handles near the top of the instruments direct the current to a signal-bell on the receiver at pleasure.

With this we must conclude our preliminary sketch of the history and the fundamental principles involved in the working of the electric telegraph. In the succeeding part of the book we shall return to the subject and deal with the developments of these principles and some of the instruments and apparatus in use in modern applications.

## CHAPTER XL

*MAGNETO-ELECTRIC INDUCTION.*

## I.—FUNDAMENTAL PRINCIPLES AND HISTORY.

IN the preceding pages we have described how the flow of an electric current produces magnetic effects in the media surrounding its path, and how by taking proper advantage of the ascertained laws of these effects, we may produce powerful electro-magnets whose magnetism is in most part, if not entirely, due to the electric currents circulating in the conducting electric circuits provided. The converse problem of how either electricity or the electric current can be produced from magnetism attracted the attention of philosophers very soon after the discovery of the magnetic effect of the current, and before this effect had been very exhaustively examined. Many curious attempts were made to solve the problem, but it was reserved for Faraday in 1831 to discover the solution in an unexpected direction, and thus to lay the foundations of a new branch of the science, a branch the importance of which has perhaps only been fully recognised during the last thirty-five or forty years.

Faraday's own description of the first clue which he obtained in the development of this wide-reaching discovery, probably the most important discovery in the science during the nineteenth century, may well be transcribed here. He says \* :—

“Two hundred and three feet of copper wire in one length were coiled round a large block of wood ; another two hundred and three feet of similar wire were interposed as a spiral between the turns of the first coil, and metallic contact everywhere prevented by twine. One of these helices was connected with a galvanometer, and the other with a battery of one hundred pairs of plates, four inches square, with double coppers, and well charged. When the contact was made there was a sudden and very slight effect at the galvanometer, and there was also a similar slight effect when the contact with the battery was broken.”

It will be noticed that the starting point of these brilliant researches was the observation of an unexpected and “very slight” effect, and hence it is sometimes said that the discovery was accidental. This can scarcely be, for it is fairly certain that this particular effect must have been produced more than once and passed unnoticed during the varied experiments of

\* “Experimental Researches,” 10, page 3, November, 1831.



the preceding ten or eleven years. In this instance, however, it was produced under the eyes of a man who was quick to note it and to recognise its importance, and of one, moreover, who, when once he had obtained this clue, followed it up with untiring industry and remarkable scientific insight, until in the course of a few brief months he had unravelled and reduced to comparative order the tangled skein of an entirely new set of complex phenomena.

For simplicity of treatment we leave the above experiment and turn to a subsequent one, published at the same time, and forming the first of a series in which the "Evolution of Electricity from Magnetism" was revealed to the world.

In this experiment Faraday used an iron ring overwound with two separate and insulated coils A and B of copper wire as shown in Fig. 383, which is copied from one of Faraday's figures.

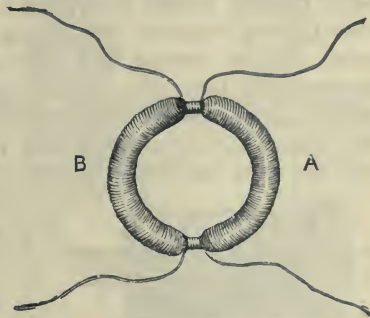

Fig. 383.—Faraday's First Induction-Coil.

These two coils were joined up in two entirely distinct and separate electric circuits, as shown in Fig. 384. The circuit of one coil A, which may be called the primary coil, consisted of the coil, a battery, and the key  $\kappa$ . The circuit of the other or secondary coil B consisted of the coil and a galvanometer G only. The experiment was performed by "making" and "breaking" circuit at the key  $\kappa$ , and observing the effect produced on the galvanometer. Faraday thus describes the results: "On making the battery circuit at the key  $\kappa$ , the galvanometer was

immediately affected and to a degree far beyond what has been described when, with a battery of tenfold power, helices *without iron* were used;



Fig. 384.—Faraday's Discovery of Magneto-Electric Induction.

but, though the contact was continued, the effect was not permanent. . . . Upon breaking the contact with the battery, the needle was again powerfully deflected, but in the contrary direction to that induced in the first instance."

Consider, now, in the light of subsequently acquired knowledge, what happens in the circumstances described. When the current from the battery is passed through the coil A, this coil acts as a magnetising coil with regard to the iron ring, through which magnetic lines flow, their total number depending, according to the laws already explained, upon the ampere-turns of the magnetising coil and the magnetic reluctance of the iron of the ring.

We shall see later that these lines do not spring into existence instantaneously, but that they grow gradually, more or less rapidly, and that there may be a very appreciable time intervening between the moment that the key  $\kappa$  is closed and the production of the full magnetic effect in the iron. Faraday proved conclusively that it was during this period that currents were produced in the secondary circuit  $B G$ , and that these currents were due to electro-motive forces produced in the circuit by the change in the magnetic lines passing through that circuit. By numerous experiments Faraday proved that these E. M. F.'s and currents are only produced when the total magnetic flux passing through the closed circuit  $B G$  is being varied, and he showed that the magnitude of the E. M. F. impressed on the circuit by this cause is proportional to the *rate of change* of this total field. It is to such experiments as these that we appeal when we assert that the magnetic lines actually pass *through* magnetic material, and differ therefore from the electric lines of force which begin and end on conductors, and do not penetrate into the conducting body.

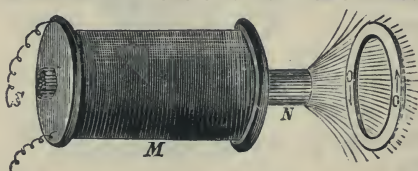

Fig. 385.—Current Induced in a Conducting Ring by an Increasing Magnetic Flux.

The direction of the induced currents in any given case, and, therefore, of the E. M. F.'s giving rise to them, can be readily determined by the following simple law, first enunciated by Lenz, and

known as **LENZ' LAW**: *The direction of the induced currents is such as to set up a field which will tend to RETARD the change which produces the currents.*

As a simple case, take a copper ring held in front of an ordinary straight electro-magnet, as shown in Fig. 385. Let the current circulating in the coil of the electro-magnet be in such a direction as to magnetise the core as indicated by the letters  $S N$ . As the current increases in the coil more and more of the lines of force proceeding from  $N$  pass through the ring  $O O$  from left to right. Whilst the field is thus increasing we shall have currents circulating in the copper ring in the direction indicated by the arrows, such currents tending to set up a field that would pass through the ring from right to left, and therefore *retarding* the growth of the field due to the electro-magnet  $M$ .

As another typical case, suppose a magnet  $N S$  (Fig. 386) to be moved in the neighbourhood of a solenoid  $B$  which is in series with a galvanometer  $G$ . As the magnet is moved towards or away from the coil along the axis of the latter, the number of lines of force of the magnet passing through the solenoid, and, therefore, through the closed circuit of solenoid and galvanometer, will be changed. With each change of the lines a current will be produced in the circuit, whilst the change is taking place, and the direction of the current will be such as to give the solenoid a polarity which

will oppose the change. Thus, in the position shown in the figure, if the magnet be moved nearer to the solenoid counter-clockwise currents will circulate in the latter which will produce (*see rule, page 276*) an effective north pole at the upper end of the solenoid, and thus tend to repel the magnet and retard the motion which is causing the induced currents. The opposite effect will be produced if the magnet *N S* be moved away from, instead of towards, the solenoid.

It is further obvious that, according to the general law, similar effects would be produced if the magnet were fixed and the coil were moved so as to produce a variation in the number of lines of force passing through it.

In making these experiments care must be taken that the motion of the magnet does not directly affect the needle of the galvanometer.

From these experiments it is but a step to the experiment depicted in Fig. 387, in which the magnet of Fig. 386 is replaced by a solenoid *P*

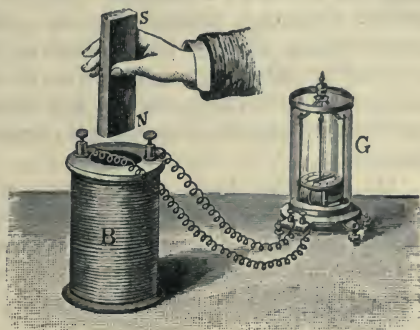

Fig. 386.—Induction of Electric Currents by the motion of a Magnet.

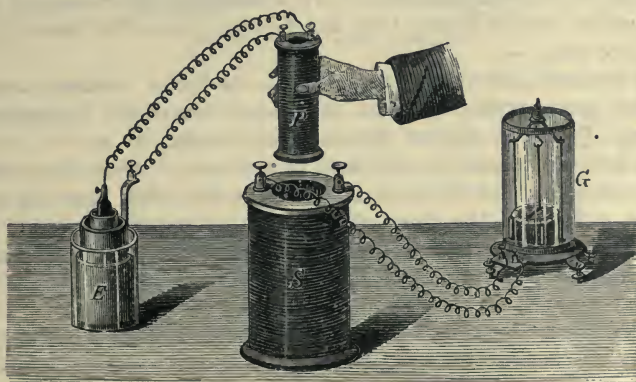

Fig. 387.—Induction by the motion of a Coil.

in circuit with a battery *E*. Assume that the current of the battery so circulates in *P* that the lower end is an effective north-seeking pole, so that in position it corresponds to the magnet of Fig. 386. By moving the coil *P* about, the same, though perhaps smaller, effects will be produced as those obtained by moving the magnet.



Let now a key be introduced into the battery circuit, so that the current in  $P$  can be made or broken at will. When there is no current in  $P$  it has no magnetic properties, and therefore sends no magnetic lines of force through  $s$ . If the key be now closed a current flows through  $P$ , which becomes, in effect, a magnet. This is equivalent to bringing up from an infinite distance a magnet into the position occupied by  $P$ , and therefore corresponding effects will be observed in the  $s$  circuit. The making of a clockwise current in  $P$  (giving a north-seeking pole at the lower end), sending lines downward through  $s$ , will induce a counter-clockwise current in  $s$  tending to send lines upwards, and therefore to retard the change causing the induction.

On the other hand, the breaking of the battery circuit is tantamount to removing altogether the magnetic properties of  $P$  and all magnetic lines passing through  $s$ . These lines, as supposed above, were downward lines, and therefore the currents induced in  $s$  will tend to set up downward lines—that is, they will be clockwise currents, retarding the removal of the lines previously there.

Lastly, suppose  $P$  introduced right inside  $s$ . If now a *clockwise current be set up* in  $P$  producing downward lines of force, the *currents induced* in  $s$  must be *counter-clockwise*, giving upward lines of force and therefore tending to retard the introduction of the downward lines. Conversely, the *breaking of a clockwise current* in  $P$  will *induce clockwise currents* in  $s$ . Though only a particular case of magneto-electric induction, this last experiment is often given as one on current induction. By developing the reasoning already used, it can be readily shown that the following so-called *laws of current induction* are true:—

1. An induced current is generated in a conductor  $b$  when a current is *started* in a near parallel conductor  $a$ , the direction of the induced current in  $b$  being *opposite* to that of the inducing current in  $a$ .
2. An induced current is produced in a circuit  $b$  when the current in a neighbouring parallel circuit  $a$  is *broken*, and in this case the induced current in  $b$  flows in the *same direction* as the inducing current in  $a$ .
3. When two closed circuits  $a$  and  $b$ , one of which,  $a$ , conveys a current, are brought near each other, an induced current is generated in  $b$ , which flows in the opposite direction to that of  $a$ .
4. When the two circuits are removed from each other, a current will be induced in the closed circuit  $b$ , which flows in the same direction as the inducing current in  $a$ . *All these currents in  $b$  are momentary currents.*

All the experiments described with the coils  $P$  and  $s$  (Fig. 387) will be much more effective, and the results greater, if either or both coils have iron cores, for in these cases the number of lines set up or destroyed will be very much greater. When  $P$  is within  $s$ , one common iron core will be sufficient for both, and in this shape it forms a piece of apparatus very widely used in telephony under the name of an induction coil

(Fig. 396), a name which is also applied to much more elaborate pieces of apparatus to be described presently. The coil *p* is usually referred to as the *primary* and the coil *s* as the *secondary*.

Suppose that in such cases the core were to consist of a solid bar of iron. The material of the core is an electrical conductor in whose substance innumerable small closed conducting circuits exist, in which currents can flow which are capable of setting up the *requisite retarding field*. When changes take place in the current in *p*, these currents would be set up in exactly the same way as that in which they are set up in the copper ring *o o* in Fig. 385. This leads to two secondary effects usually undesirable. In the first place the change in the current in *p* is delayed, and in the second place the energy of the currents in the iron core is converted into heat, and the core may become very hot if the changes in *p* are rapid and long continued.

To avoid these effects the *core should be laminated* in such a way as to destroy the continuity of the circuits in which currents, capable of setting up the retarding fields required by Lenz' Law, can be induced.



Fig. 388.—Higher orders of Induction.

These circuits are in planes at right angles to the lines of force, and the necessary lamination is usually obtained by making the core of bundles of iron wire, each wire being either carefully varnished or sufficiently dirty and rusty on the outside to prevent appreciable currents passing sideways from one wire to another. This kind of lamination is clearly shown in Fig. 396.

**Higher Orders of Induction.**—The similarity in the effects produced by voltaic and induced currents led to the idea that induced currents in their turn must be capable of inducing other currents in conductors near them. Professor Henry, of Princeton, proved this to be the case by using several coils of copper bands parallel to each other. Fig. 388 (I II III IV) shows how he arranged them. Making or breaking contact in the circuit in which I is placed induced a current in II, which flowed also through III; the wires of IV terminated in metallic handles *e f*, and the person touching *e f* received a shock due to the induced currents in IV. Induced currents of this kind are said to be of a higher order. The induced current of IV is one of the second order. Currents of a higher order cannot very well be simple currents, as the

appearance or disappearance of the inducing current causes two induced currents, the direction of the first induced current being opposite to the second. Let us suppose the current produced in *i* clockwise, the direction of the current in *ii* on "make" will be counter-clockwise; this induced current flows through *iii*, and induces in *iv* two currents of the second order, viz., one clockwise whilst it is increasing and one counter-clockwise whilst it is dying away. When the clockwise current in *i* starts, a counter-clockwise transitory current in *iii* begins and quickly subsides. While it increases it induces a clockwise current in *iv*, and while it decreases it produces a counter-clockwise current in *iv*. When the current in *i* stops, in a similar manner it causes a transitory clockwise current, which in increasing and decreasing causes oppositely directed induced currents in *iv*. If these currents be led to a fifth coil, induced currents again would be produced in a sixth coil, and as these induced currents of the second order produce opposite effects as they rise and fall, induced currents of the third order will be generated, and so on. In this manner, by proper arrangement of the coils, induced currents of a fourth and fifth order might be obtained and their existence proved by their physiological effects or otherwise.

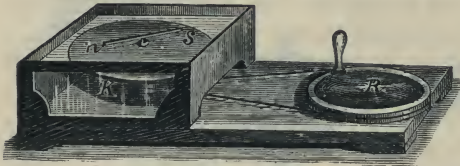

Fig. 389.—Arago's Rotations.

The earth's magnetism induces currents when closed circuits are made to move so as to cut the lines of force. This kind of induction, too, was first observed by Faraday. He connected the ends of a coil

with a galvanometer, the coil being so arranged that its plane stood at right angles to the dip or inclination needle. When the coil moved through  $180^\circ$ , so that the lines of force passing through are all taken out and then put in again in the reverse order, the deflection of the needle indicated a current induced by the earth's magnetism. The effect is increased by multiplying the turns of the coil, and by placing iron cores within it.

**Arago's Rotations.**—A number of interesting induction phenomena were observed as early as 1824 by Arago, and called after him Arago's rotations. He found that when a disc of copper is made to rotate in its own plane, and a magnetic needle is placed over it, the needle turns round in the same direction as the disc. The apparatus is shown in Fig. 389. The copper plate *κ* is enclosed in a glass case, and can be made to rotate rapidly by means of a multiplying wheel *R*. Above the horizontal glass plate of the case the needle *n s* moves freely upon a pivot. The velocity of the needle increases with the velocity of the disc. If the copper plate be perforated the effect is diminished. Variations of the effect are obtained by substituting different metals for the copper plate. We shall discuss this experiment more fully later.



## II.—SELF-INDUCTION.

The fundamental principle of magneto-electric induction is that whenever the number of the magnetic lines of force passing through a closed circuit is altered currents are induced in the circuit whose magnetic effect retards the change which is taking place. But when a current is set up in a circuit, that current gives rise to lines of force which necessarily pass through the circuit. This introduction of lines of force will tend, according to the fundamental law, to produce currents in the circuit which will tend to retard the change taking place—that is, the growth of the field, and therefore the growth of the current which is setting up the field.

The circuit is therefore said to have *self-induction*, and the existence of self-induction explains a remark previously made (see page 418), that the current in a circuit does not instantaneously attain its final value. Conversely, when a circuit is broken the disappearance of the magnetic field will be attended by inductive effects. These are frequently manifested by the appearance of a more or less *vivid spark* at the point where the break is made. To explain the existence of this spark, which usually indicates the presence of a high P. D. between the two sides of the break, we must look at the inductive phenomena from another standpoint.

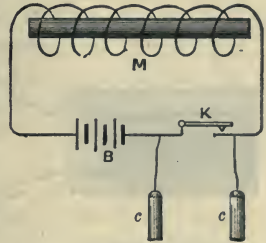

Fig 390.—Self-Induction of Current.

Whenever an electric current flows in a circuit there must be (see page 145) an E. M. F. in that circuit, and induced currents are no exception to this rule. Faraday showed that the *E. M. F. of magneto-electric induction* is proportional to the *rate of change of the number of magnetic lines* enclosed by the circuit. (Lenz' law gives the direction of this E. M. F.) But the lines of force are closed curves, and therefore cannot pass into or out of the above enclosure without cutting one or the other of the conductors which form the boundary. It may be inferred, therefore, and experiment justifies the inference, that *whenever a line of force moves across a conductor an E. M. F. is set up in the conductor, proportional to the rate at which the magnetic lines are moving across it.* This is a more general law than the one previously given.

Returning now to the "spark at break," consider the simple circuit shown in Fig. 390, and consisting only of a battery B, an electro-magnet M, and a key K. When the current is fully established there will be a great number of magnetic lines passing through the core of M. When the circuit is broken these lines in disappearing must cut the loops of the magnetising spiral with great rapidity, each line cutting all the loops and setting up an E. M. F. in each. All these E. M. F.'s are in the same direction, and tend to keep up the strength of the disappearing current. Consequently, as the gap at K widens, a P. D.

suddenly appears between the two sides sufficiently great to rupture the air and give a vivid spark. Even with a small battery the P. D. indicated by this spark may mount up to hundreds of volts. This sudden rise of P. D. will be evident to anyone who grasps the two handles *c c*, one on either side of the gap. If the electro-magnet *m* be a large one a very unpleasant physiological shock will be experienced.

Another arrangement for showing the existence of an E. M. F. in the coils of an electro-magnet from which the current is being withdrawn is shown in Fig. 391. Wires lead from the battery *B* to the coil *s*, and from the points of the circuit indicated at *a* and *b* wires branch off to the galvanometer *G*, so that the galvanometer forms a kind of shunt on the coil *s*. When contact is made at *k*, the current flows from the battery towards *a*, and divides here into two branches: one branch flows to the galvanometer, the other branch flows through *s*, meets the first branch at *b*, and both return to the battery again.

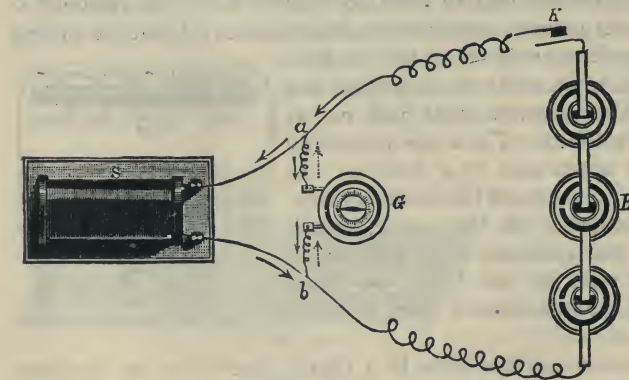

Fig. 391. —Experiment on Self-Induction.

When contact is made at *k*, the current flows from the battery towards *a*, and divides here into two branches: one branch flows to the galvanometer, the other branch flows through *s*, meets the first branch at *b*, and both return to the battery again. This current is indicated by dark arrows. The deflection of the needle which this current

would cause is prevented by fixing a pin in front of the needle. The branch current cannot now deflect the needle, it only causes it to press against the pin. When contact is broken at *k*, however, the inductive E. M. F.'s set up in the coil *s* which tend to set up a current towards *b* give rise to currents in the closed circuit consisting of the coil *s* and the galvanometer *G*. These currents cause the galvanometer needle to move in the opposite direction to that of the pin. This so-called extra current is shown in the figure by the dotted arrows; it enters at the *b* terminal of the galvanometer, whilst the direct current previously entered at the *a* terminal. When an electro-magnet is shunted in this way it is observed that the spark at *k* on breaking circuit is very much less vivid. This observation is worthy of careful consideration.

**Energy of the Magnetic Field.**—We have already pointed out that the magnetic lines of which we speak so familiarly are simply a convenient method of indicating the state of elastic strain into which the medium is thrown by the magnetising forces. Energy must be spent in setting up this

state of strain, though none is required to maintain it. The phenomena of self-induction enable us to trace the energy changes a step further than we could without their aid. As the field (Fig. 391) is being set up by the growing current, back E. M. F.'s are induced in the circuit, and the battery current in working against these back E. M. F.'s has to spend energy. It is this current energy (derived from the battery) so spent which appears as magnetic strain energy in the magnetic field. Without the back E. M. F.'s no energy could be taken from the battery circuit, and thus it becomes evident that the phenomena of self-induction are a necessary link in the process by which energy is transferred from the battery circuit to the magnetic field.

Conversely, when the circuit is being broken the stored energy of the magnetic field is passed back again into the circuit by means of the inductive E. M. F.'s generated. In this case the E. M. F.'s are forward ones; they help the battery current by bringing back the energy previously absorbed into the circuit, and it is this energy from the disappearing magnetic field which causes the light and noise of the "spark at break." Consequently the greater the energy of the field which is being suppressed the greater and more vivid is the spark; thus when electro-magnets are in the circuit the sparks, even with small currents, are much more brilliant than they are with much larger currents when there are no electro-magnets. This can easily be tested by experiment.

Further, when the electro-magnet is shunted, as in Fig. 391, part of the energy of the field is expended in driving the currents round the closed circuit consisting of *s* and *g*. The conductors in this circuit, becoming heated, absorb some of the energy, and therefore there is a smaller quantity to be dissipated at *k*, and the spark there becomes much less vivid.

The laws of magneto-electric induction are of great importance in numerous applications of electricity to the service of man, more especially in engineering work. Before dealing with this work, however, a few pages may profitably be devoted to the early history and development of "Induction Coils," which apply Faraday's discovery in the simplest and most direct way and in one form or another are now widely used.

### III.—TRANSFER AND TRANSFORMATION OF ENERGY.

**Transfer of Energy through the Medium.**—Attention should first, however, be directed to an important aspect of the above phenomena. It is this, that there is an actual transfer of energy from the primary circuit to the secondary circuit, and that this energy must reach the latter from the former through the intervening insulating medium. For it is obvious that energy does reach the secondary circuit in some manner, because the electric currents generated can be made to do work, as we shall see later, or can heat the conductor as they do in the above experiments. But energy cannot be either created or destroyed, and the only



source of energy in the experiment is in the primary circuit. From this circuit, then, the energy of the electric currents set up in the secondary circuit must be derived, and in its transmission the magnetic actions in the medium evidently play an important part.

But though in both circuits the energy is electrical, it may take very different forms in the two cases. Thus in one circuit the energy lost may be noted in the temporary diminution of the strength of a continuous current driven through the circuit at a somewhat low voltage. This energy may reappear in the form of a rapidly alternating current at a much higher voltage. Or, again, in both circuits the currents may be alternating, but the voltages and current strengths may be very different. What we have to remember is that the factors of electrical energy or work are pressure, current and time, or in symbols—

$$W = E C t,$$

where  $w$  is the work or energy,  $E$  the pressure or voltage,  $c$  the current or ampère, and  $t$  the time. In the phenomena now being considered the element of time may be disregarded, for it is the same for both circuits, and therefore, on balance, cancels out. In other words, the appearance of the energy in one circuit is coincident in point of time with its disappearance from the other, the transfer being practically instantaneous.

If there were no loss in the transformation we should, therefore, have the equation—

$$E_1 C_1 = E_2 C_2,$$

where the left-hand side represents the power taken from the inducing or *primary* circuit, and the right-hand side the power appearing in the circuit acted upon, usually called the *secondary* circuit. In practice there is always some loss due to irreversible heating effects, and therefore the second product is only approximately equal to the first. The equation, however, shows that, whilst rigorously satisfying the conditions, the amperes and the volts may differ widely on the two sides. Thus in the primary circuit we may have

$$E_1 = 100 \quad C_1 = 20 \quad E_1 C_1 = 2000$$

and in the secondary circuit

$$E_2 = 2000 \quad C_2 = 0.95 \quad E_2 C_2 = 1900.$$

To avoid misconception as to the meaning of the symbols used the following points should be borne in mind :—

- (i.) The pressure  $E_1$  in the primary circuit is the inductive pressure or back E. M. F., without the existence of which power could not be taken from the circuit.
- (ii.) The values of all the quantities are *mean* values properly measured, for from the nature of the actions the actual values are necessarily changing from instant to instant.

## IV.—BATTERY INDUCTION COILS.

The special pieces of apparatus, by which advantage is taken of the above phenomena to produce certain effects or changes, are variously known as "induction coils," "secondary generators," "transformers," or "converters," the distinction between the first and the others being chiefly based on the different methods by which the essential variation of the current is produced in the primary circuit. In early days, when battery currents were practically the only ones available, the "induction coil" was developed. More recently, and since rapidly alternating currents from dynamo machines have become common, the same physical principles have been applied to the

"transformer," or "seconding generator" or "converter," which is sometimes still further particularised as the "alternate current" or "static" transformer to distinguish it from other transformers of electrical energy in which there are moving parts. Taking the subject in the order in which it has developed, we shall deal with the "induction coils" first.

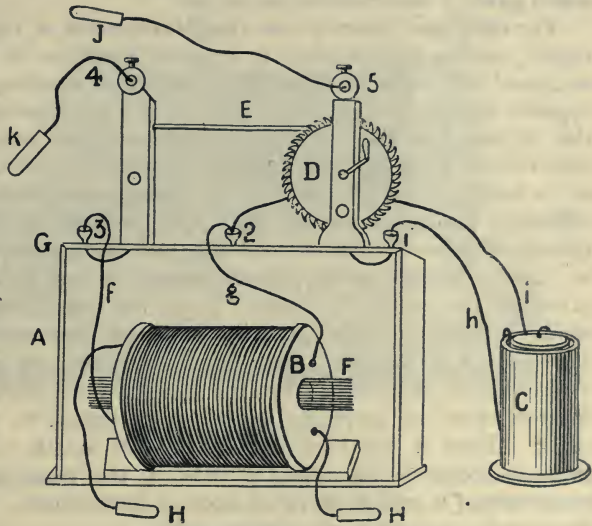

Fig. 392.—Bachhoffner's Induction Coil (1837).

### Historical

**Notes.**—The first induction coils were undoubtedly those used by Faraday in his classical researches on magneto-electric induction (pages 416 to 420), and the coil shown in Fig. 383 has much in common with the modern static transformer. It was used, however, by Faraday (Fig. 384) with a battery and a break-circuit key. At each make and break of the key *k* a transient current passed through the galvanometer. Faraday's discoveries excited great interest, and, in addition to Faraday, Sturgeon, Henry, Hare, and many others worked at the subject. In those days the primary and secondary coils were usually wound over one another on the same core, and it was not long before mechanical contact-breakers replaced the key *k* of Faraday's early work.

One of these early mechanical contact-breakers, often re-invented since, is shown in Fig. 392. It was constructed by Bachhoffner, of London, in

1837. The coil B, made by Sturgeon, is wound with two circuits,  $f g$  being the terminals of the primary and  $h h$  those of the secondary circuit;  $c$  is the battery whose wires  $h$  and  $i$  are led to the mercury cups 1 and 2, whilst  $g$  and  $f$  are connected to the cups 2 and 3. The brass columns  $o o$  are also connected to the cups 1 and 3. The current from the battery wire  $h$  passes between the columns  $o o$  through the ratchet wheel  $D$  and the steel spring  $e$ , then through the primary coil and back to the battery by cup 2 and wire  $i$ . If the wheel  $D$  be turned the battery circuit is broken and made again as the spring  $E$  slips from one tooth to another. The best effects were said to be obtained with Bachhoffner's apparatus when the wheel was turned at a speed which gave 72 interruptions per second.

For such rapid interruptions the galvanometer of Fig. 384 would give no results, because it is deflected in opposite directions at make and at break, and could not move in either direction before receiving the impulse in the opposite direction. The physiological effect was, therefore, used as a test of the efficiency of the apparatus. This effect, to which we have already referred (*see* page 137), is experienced whenever two parts of the body—as, for instance, the two hands—are suddenly subjected to a high potential difference causing a sudden discharge through the body. The nervous system is seriously affected and the muscles contract, and if the P. D.'s be rapidly varied, very painful sensations are experienced, which in extreme cases result in death. It is the rapid variation of the P. D. which appears to produce these nervous disturbances; an excessive but steady P. D. produces other effects, to which we may allude later.

It will be understood that the physiological effect, which necessarily depends upon the particular experimenter, cannot be made strictly quantitative. Later it has been replaced by the length of spark that can be produced between the separate ends of the secondary circuit, but this measurement is only to be relied upon as approximate. For accurate work the electrical quantities must be measured.

In Bachhoffner's apparatus, besides the two handles  $h h$  at the ends of the secondary circuit, two other brass cylinders  $j, k$  were connected one on each side of the break in the primary circuit in exactly the same position as the handles  $c c$  in Fig. 390. The inductive effect on breaking the primary circuit would be thrown on to these terminals ( $j, k$ ), and could be observed by grasping them with moist hands. Bachhoffner observes that using only a single cell the effect "is so unsupportable that anything like grasping the conducting tubes with the hands moistened is out of the question."

Bachhoffner appears to have been the first to observe that the coil is more effective with a bundle of insulated iron wires for the core than it is when a solid iron bar is used. He used common covered bonnet wire, and estimated that "the power of the instrument was increased at least twofold." He gives no explanation of this result, but we now know (*see* page 421) that it is



due to the suppression of induced or "eddy" currents in the continuous solid iron mass.

The next great step in developing the battery induction coil was to replace the mechanical contact-breaker by an electro-magnetic contact-breaker actuated by the primary current. Such breaks were devised by Masson and Bréguet, Du Bois-Raymond, and others, especially Ruhmkorff, who introduced many improvements in the details of the coil, so much so that it is still often referred to as the "Ruhmkorff Coil." One form is illustrated in Fig. 393, with an electro-magnetic contact-breaker at the side,

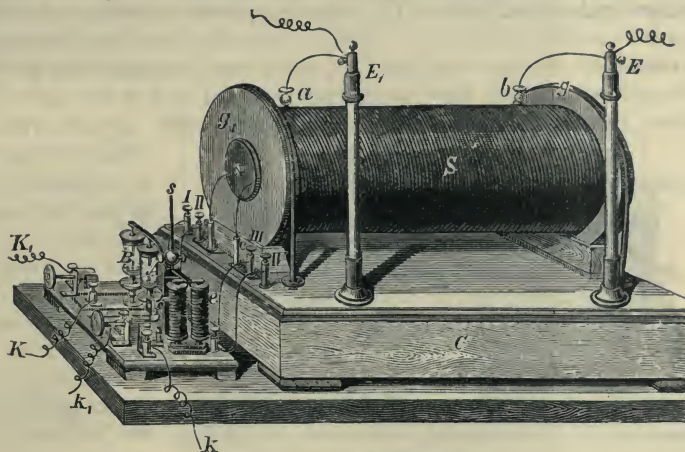

Fig. 393.—Ruhmkorff's Inductorium.

as devised by Poggendorff and constructed by Foucault. The terminals of the primary or thick wire circuit are brought to the screws II and III, whilst the terminals of the secondary are taken to  $E_1$ ,  $E$ , which are very carefully insulated on glass pillars, for the P. D. between them may rise to many thousands of volts. The box  $c$  contains a condenser whose terminals are connected to I and IV, and whose presence increases the length of the spark, for reasons we shall give later.

The contact-breaker is driven by a separate cell attached to the binding screws  $k$   $k_1$ , the larger battery for the primary circuit being connected to the terminals  $K$   $K_1$ . The electro-magnet  $e$  and the mercury cup  $A$  form with the auxiliary cell the contact-breaker circuit. Whenever current flows in this circuit the magnet is excited and draws down the armature; this action breaks the circuit in the cup  $A$ , the magnetism disappears, the armature is released, and the lever is rocked back again by the weights at the far end over-balancing the weight of the armature. In this way the contact is again made in  $A$ , and the cycle of operations is repeated. The same lever carries a second contact point dipping into the mercury cup  $B$ . This contact forms

part of the primary circuit, which is therefore made and broken simultaneously with the circuit of the magnet  $e$ . The upright rod  $s$  is attached to the rocking lever, and carries a sliding weight, by raising and lowering which the rate of vibration of the lever can be varied.

As the current in the primary circuit rises and falls magnetic lines of force are threaded through and withdrawn from the secondary circuit, in each turn of which, therefore, in accordance with Faraday's laws of magneto-electric induction, E. M. F.'s are set up which, being added together, bring a disruptive potential difference on to the terminals  $E_1, E_2$ .

**Modern Induction Coils.**—The successful production of a good induction coil requires careful attention to a number of details, the chief of which relate to the insulation of the primary and secondary coils, but especially the latter. The insulating materials must be carefully selected and be the best of their respective kinds. Wires whose potentials will differ greatly when the

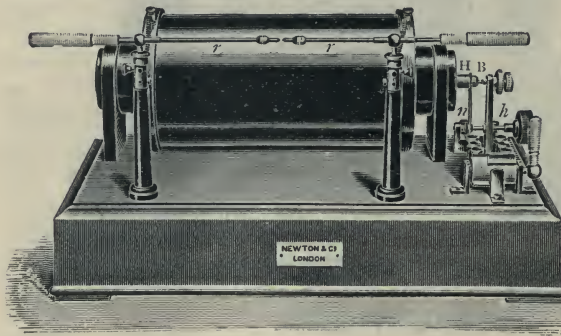

Fig. 394.—Modern Battery Induction Coil.

An excellent type of a modern induction coil is shown in Fig. 394. The particular coil illustrated is built by Messrs. Newton and Co., from the designs of Mr. Apps, who for many years has been the leading English manufacturer of these coils. The general connections are given diagrammatically in Fig. 395.\* The same letters are used for the corresponding parts in both figures.

The primary circuit starting from the battery passes to the terminal  $\tau_1$  and then through the upright column  $h$  to the break-gap B. When this gap is closed the current can flow through the hammer H, the thick primary coil P P, and back to the battery through the terminal  $\tau_2$ . The secondary circuit s s, represented by the spiral of fine lines, has its ends brought to the terminals  $t t$ , which are carefully insulated on long ebonite columns and carry the discharging rods  $r r$ . These rods are provided with corrugated ebonite handles, and pass through balls which are carried on universal joints so that they can be quickly set in any desired position and with their ends at any required distance apart.

\* This figure is taken from "The Electric Current" (1894), by Dr. R. Mullineux Walmsley.

coil is working must be separated as far as possible from one another. When such separation is not possible extra insulation must be interposed to prevent disruptive sparks passing from wire to wire inside the coil.

An excellent type of a modern

The two coils are wound upon the laminated core  $\tau \tau$ , which consists of a bundle of iron wires insulated from one another as recommended by Bachhoffner. The primary core, consisting of a few turns of thick copper wire, is wound on first, and has an ebonite tube slipped over it to insulate it from the secondary, which is wound outside the tube. The tube projects some distance beyond the secondary coils, and has a number of ebonite discs threaded on to it, separated by narrow rings which act as distance pieces. The secondary coil is wound in a series of flat spirals in the spaces so formed, and thus parts of the coil, at widely different potentials, are kept well apart. The different sections are connected in series so that all the induced E. M. F.'s are added together.

The contact-breaker, known as a Nieff hammer, consists of a piece of soft

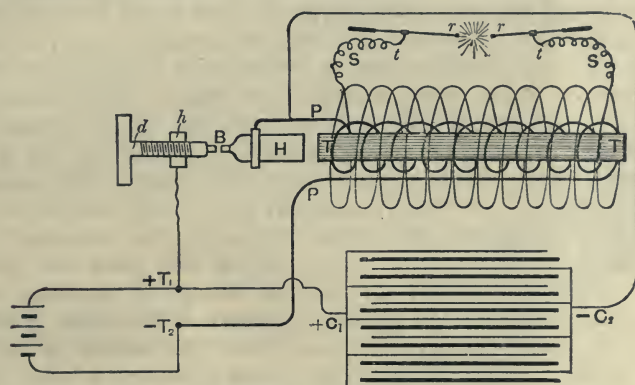

Fig. 395.—Connections of a Battery Induction Coil.

iron  $H$  carried on a spring  $n$ , which is so set up, that when there is no magnetism in the core  $\tau \tau$  the gap  $B$  is closed by the action of the spring. When the primary current flows the core  $\tau \tau$  becomes magnetised and attracts the hammer head  $H$ , thus opening the gap  $B$  and breaking the primary circuit. The primary current then ceases, the magnetism disappears,  $H$  is pulled back by the spring  $n$ , and the gap  $B$  is again closed and the primary circuit completed once more. The same cycle of operations is repeated again and again. With each rise of the current magnetic lines of force pass through the core  $\tau \tau$ , and the return path, spreading outwards, cuts more or less of the wires forming the turns of the secondary coil. In accordance with Faraday's general law (see page 418) each turn of the secondary coil has an E. M. F. induced in it "proportional to the rate at which the magnetic lines are moving across it." Whilst the primary current is growing all these E. M. F.'s are in the same direction in the wire of the coil and are therefore all added together. As the secondary coil consists of thousands of turns the total E. M. F. set up at a given instant by the growing magneti-



sation of the core may be very great. Similar E. M. F.'s, but in the opposite direction, are set up when the core is losing its magnetism on the cessation of the primary current.

A little consideration will make it evident that the total Impulsive voltage thrown on the terminals  $t t$  at any instant depends on the *rapidity* with which the magnetism of  $T T$  is built up or removed. One of the effects of the condenser  $C_1 C_2$  is to increase the effect at the breaking and to diminish the effect at the closing of the primary circuit

It will be noticed that one terminal of the condenser is connected to  $h$  (through  $T_1$ ) and the other to  $H$ , so that the condenser bridges the gap  $B$  and is short-circuited when this gap is closed. We have now in the apparatus two means of storing electrical energy; when the battery current is flowing in the primary coil magnetic strain energy is stored in the iron core and the surrounding medium. This energy, as previously explained (*see* page 425), is returned to the circuit by the action of self-induction as the battery current begins to diminish in the initial periods of the break. The P. D. across the break rapidly rises and, in the ordinary case, the whole of the stored energy, except such of it as may be picked up inductively and used in the secondary circuit, would be spent in a vivid spark. The condenser, the other storehouse for energy, however, is at hand, and as the P. D. across the gap rises, some of the energy rushes into the condenser, which becomes charged. Two effects follow: in the first place the spark is much less vivid and vicious because less energy is available for its production and therefore the platinum contacts at the break points are preserved. In the second place, because of the rapid transfer of its stored magnetic energy to the condenser the primary current is more quickly wiped out and the inductive effect on the secondary circuit at break is increased.

At the instant when the break is complete we are left with the plates of the condenser charged to a high P. D. But although the gap  $B$  is open the terminals of the condenser are still connected by conductors through the coil  $P P$ , the terminals  $T_1 T_2$  and the battery. The condenser, therefore, immediately begins to discharge by this path, and in doing so sends a current through  $P P$  in the direction opposite to that in which the battery current flows. Incidentally we may remark that the starting of this current tends to increase further the inductive effect at break. Suppose now the gap  $B$  is closed, by the swing of the hammer, before this discharge current dies away. At the moment of closing the contact there will be in the circuit not only the battery E. M. F. but also the back E. M. F. of self-induction, due to the falling discharge current. The rise of the current in the circuit will, therefore, not be so rapid as it would be if the battery E. M. F. were acting alone. Thus the rise of the battery current is retarded by the action of the condenser, and the inductive effect in the secondary circuit will be diminished because it depends upon the *rate of change* of the magnetic flux through the

secondary coils. The discharge between the ends of the rod  $rr$  is therefore unidirectional, for if the distance between them be sufficiently great and the speed of the break properly adjusted the P. D. at make will seldom rise high enough to rupture the dielectric. In any case the spark at break is much more vivid than the reversed spark at make.

The condenser, which should be constructed with mica for its dielectric (see page 120), is placed in the hollow box on which the induction coil stands.

**Modern Contact-Breakers.**—Within the last few years several forms of contact-breakers have been devised which, for certain purposes, are much more effective than the Nieff hammer or the older forms of electro-magnetic contact-breaker. We describe some of these later on.

#### V.—ALTERNATE CURRENT OR STATIC TRANSFORMERS.

To produce an effect in the secondary circuit of an induction coil, it is essential that the current in the primary circuit should be caused to vary. In the induction coils just described the necessary variation was produced by interrupting the circuit of a voltaic battery, thus causing pulsating but still unidirectional currents to flow through the primary coil.

A much more subtle method of producing rapid variations in an electric current is by the use of the microphone transmitter employed in telephony. This instrument, which is described fully elsewhere, when sound waves fall upon its diaphragm, alters the resistance of the electric circuit in which it is placed. This circuit contains a battery of constant E. M. F., and therefore, by Ohm's law, when the resistance is changed the current also fluctuates. For good transmission it is frequently desirable that the low voltage of the battery circuit should be considerably raised, and for this purpose an induction coil is invaluable if not indispensable. The form of coil required, however, is very simple. For the reasons just given no contact maker is necessary, and we require only the two insulated copper circuits wound upon a laminated iron core as shown in Fig. 396. Here the two terminals  $P_1 P_2$  lead to a low resistance coil consisting of comparatively few turns of thick wire, and the terminals  $S_1 S_2$  to a coil of higher resistance with more

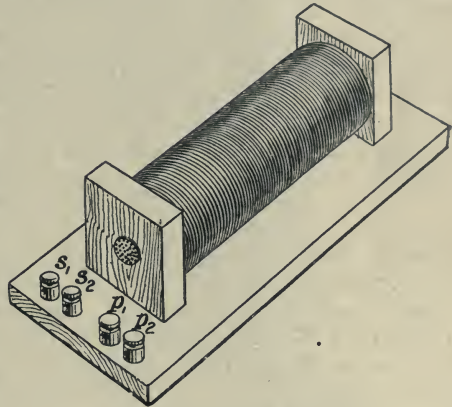

Fig. 396.—Telephone Induction Coil.

numerous turns of finer wire. Any fluctuations of voltage impressed on the terminals  $P_1 P_2$  will lead to a much higher fluctuation of voltage at the terminals  $S_1 S_2$ .

But there are other highly important methods of producing variable currents which may be passed through the primary circuits of induction coils. During the last thirty years there has been developed a type of dynamo electric machines, known as alternators, which generate continuously varying currents which change their direction many times in a second. Such currents starting from zero rise to a maximum in, say, the  $\frac{1}{400}$ th of a second, sink to zero again in the next  $\frac{1}{400}$ th, rise to a maximum *in the reverse direction* in the next  $\frac{1}{400}$ th of a second, and sink to zero again in the next  $\frac{1}{400}$ th. A complete and continuous cycle of changes is, therefore, gone through in the  $\frac{1}{100}$ th of a second, and these changes can be repeated over and over again for any length of time. Such currents are, therefore, *par excellence* the currents with which to feed the primary circuit of an induction coil, for, since they are continually changing, E. M. F.'s will be continually produced in the secondary circuit which, if a closed circuit, will be continually traversed by currents, which must obviously change as often, though not necessarily at the same instant, as the currents in the primary circuit. These induced currents are, therefore, also alternate currents.

The general equation (*see* page 426) connecting the amperes and the volts in the two circuits, viz. :—

$$E_1 C_1 = E_2 C_2 \text{ (approximately),}$$

holds in this case also. In the coils hitherto described the object was to obtain from the comparatively low voltage of the battery a much higher voltage capable of giving physiological and other high voltage effects. Though it was quite possible to work the other way,\* no useful object would be served by placing the battery in the circuit of the coil with many turns and using the coil with few turns as the secondary coil. The voltage in the secondary would then have been much lower than the already low voltage in the primary. In other words, the battery induction coils were always used as "step-up" transformers. With the advent of the alternate current and its use in heavy electrical engineering, the uses of induction coils were considerably extended, and, as we shall see in the sequel, cases frequently arise in which "step-down" as well as "step-up" transformers are required.

**Historical.**—Although the use of induction coil transformers had been previously suggested by others, the first to employ them on an engineering scale, under the title of "secondary generators," were Gaulard and Gibbs in 1883, when several stations on the Metropolitan Railway in London were lighted with alternate currents from the secondary circuits of the coils. The apparatus is shown in Fig. 397; it consisted of sixteen long straight

\* Whitwell in 1866 (*Electrician*, vol. xxviii., 1891, p. 130) had tried a "step-down" experiment.



induction coils standing vertically and suitably supported. They had straight iron cores arranged in groups of four with gearing for lifting each group out of its coils, and thus altering the inductive effect. The thick wire, 0.16 inch in diameter, formed the central wire of a 49-strand cable; the other 48 wires, each 0.02 inch in diameter, in six groups, formed the fine wire coil. Switches for making various combinations of the thick and fine wire circuits were provided.

The experimental installation of Gaulard and Gibbs was not very successful, but two or three years later there was a rapid development of electric lighting by alternate currents, in which transformers played an important part. Attention was, therefore, directed to the details of their design, and many new patterns were brought out in a comparatively short space of time.

The transformers produced fall into two general classes, called respectively

“open-circuit transformers” and “closed-circuit transformers.” The adjectives refer to the magnetic and not the electric circuit. In the first class, or “open-circuit” transformers, the iron core was straight (or nearly so), as in the induction coils already described, and the circuit of the magnetic flux was completed through the surrounding non-magnetic medium (*i.e.* the air, etc.). In the second class the magnetic flux was provided with a circuit consisting

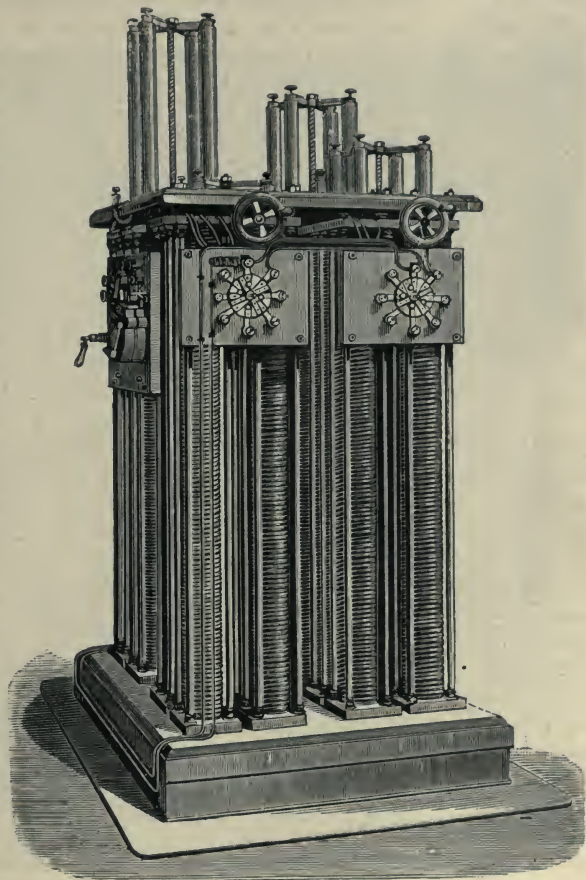

Fig. 397.—Gaulard and Gibbs' Secondary Generator.

as completely as possible of good magnetic iron. In other words, the circuit was "closed" through good magnetic material. A fierce controversy raged for some time between the advocates of the two classes as to their respective merits, but for heavy engineering work the "closed-circuit" transformers are now exclusively used. We propose to refer to the points in dispute later, and shall now be content to describe two or three of the transformers produced about the time named and to postpone to the later section the description of some of the transformers now in use for general and special work.



Fig. 398.—Swinburne's "Hedgehog" Transformer.

*Open Circuit Transformers.*—In addition to the Gaulard and Gibbs' transformer already described, the open-circuit transformer designed by Mr. James Swinburne, and known as the "Hedgehog" transformer, was at one time widely used. Fig. 398 shows its outward appearance with the non-magnetic case removed. Through the centre passed a cross-shaped gun-metal casting, spread out at one end to form the legs and at the other to take the terminal board. Four bundles of soft iron wire were put into the four recesses of this core, and the end of the wires were spread out, giving the rough prickly appearance shown in the figure, from which the transformer was named. The iron wire was taped over and the secondary circuit wound on it. Then two layers of ebonite were slipped over the secondary circuit and the primary circuit wound outside it in two compartments separated by ebonite, with which also the terminal flanges were faced. The ends of both circuits carefully insulated were brought out at the top, and the whole transformer encased in a stoneware jar, in which no eddy currents could be formed, and which was also non-magnetic.

Another transformer of this type was the "Cable" transformer of Messrs. Siemens Brothers and Co., shown in Fig. 399. The cable may be roughly described as a submarine cable turned inside out, the iron being *inside* and the copper *outside*. The core consisted of wire rope made of soft iron wires which were covered with a specially-prepared insulating material. Round this were wound the two conductors of copper wire which were to form the primary and secondary circuits. The transformer was now

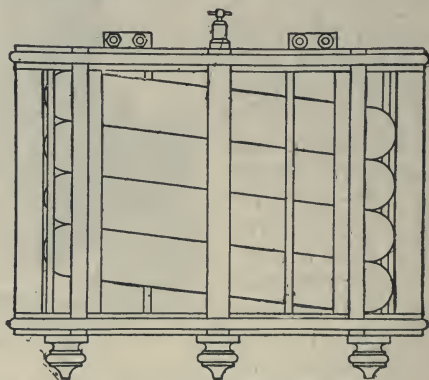

Fig. 399.—Siemens' Cable Transformer.

practically complete. It could be used either laid out straight, or suspended in a more or less horizontal or vertical position, or it could be coiled up and put in a skeleton frame, as shown in the figure, with the terminals of the circuits placed on the top. The 150 horse-power transformer had an efficiency of 94 per cent. at full load, 93 at half-load, and 90 at quarter-load.

In working with high potentials it is customary to immerse the trans-

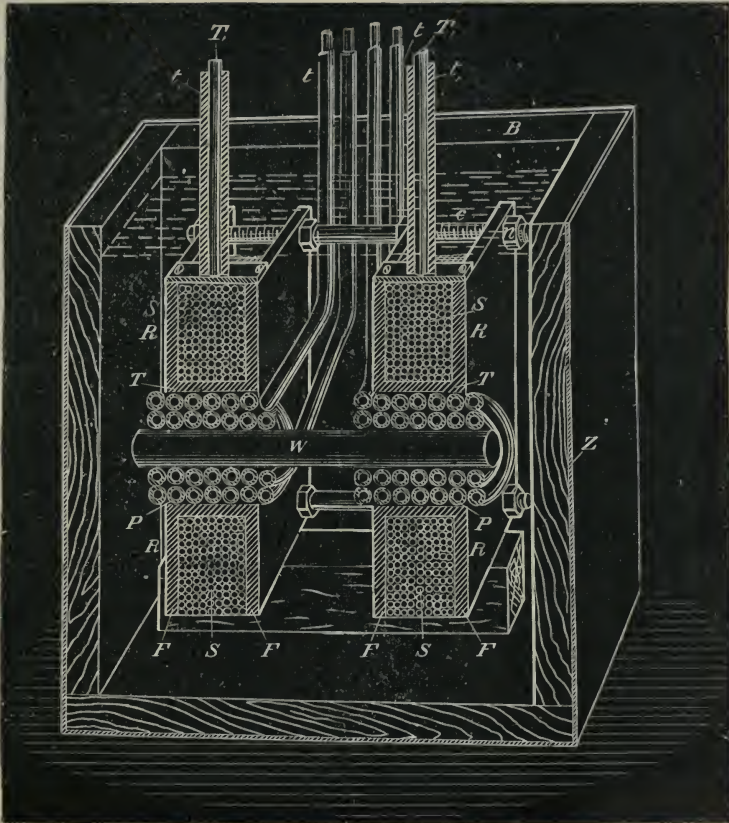

Fig. 400.—Tesla Transformer for High Potential Working.

former in an insulating oil in order that, in the event of a spark passing through and puncturing the solid insulation, the oil may close round the puncture and preserve the insulation. Mr. Tesla, in his high potential work, was one of the earliest to use oil as an essential part of the insulation of a transformer. His transformer was also of the open circuit type, and though not used for engineering work it will be convenient to refer to it here.

The Tesla high potential transformer is shown in section in Fig. 400.



The thick wire or primary coil  $P P$  was wound upon a wooden mandrel  $w$  in two sections, the four ends of which were led out through ebonite tubes  $t t$ . Each coil consisted of four layers of 24 turns each, insulated

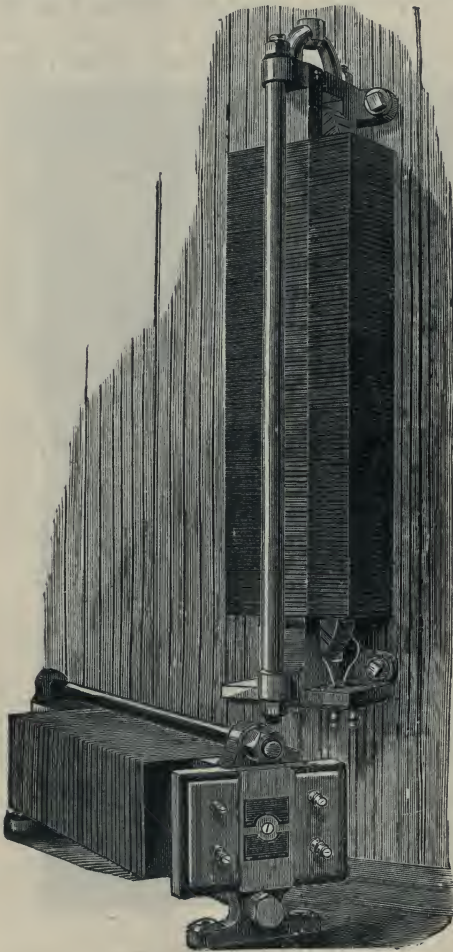

Fig. 401.—Mordey's Transformer.

from one another by cotton cloth. The fine wire or secondary coil  $s s$  was also wound in two sections on ebonite bobbins  $R R$ , each consisting of a tube  $T T$  3.2 inches internal diameter and 0.12 inch thick, with flanges  $F F$  9.6 inches square and 1.2 inches apart. Best guttapercha-covered wire was used, and each coil consisted of 26 layers of 10 turns, also separated from one another by cotton cloth. The two halves were wound oppositely and connected in series and the ends led out through the thick ebonite tubes  $t_1 t_1$ . To prevent sparking from primary to secondary it is well to connect the middle point of the latter with the former. The coils were clamped about two inches apart by wooden clamps, and fixed with wooden supports in a wooden box  $B$ , surrounded by a sheet of zinc  $z$  carefully soldered all round. The box was filled with insulating oil, which, if a spark should pass, closes up again and restores the insulation.

It will be noticed that, in this transformer, not only is the return path for the magnetic lines through non-magnetic material, but that the core is non-magnetic also. In fact the transformer is an "ironless" transformer.

*Closed Circuit Transformers.*—Faraday's first induction-coil (Fig. 383) was a transformer of this class, for the magnetic circuit was completed through the iron of the ring. Coming down to the development of electric

lighting with alternate currents, referred to above, one of the transformers most widely used then was the *Mordey transformer*, manufactured by the Brush Electrical Engineering Company.

In this transformer (Fig. 401) the primary alternate current was led in at two of the binding screws shown on the end plate of the apparatus, and the secondary current was taken off from the other two. The construction of the working parts will perhaps be better understood by a reference to Fig. 402, which represents a section through the electric and magnetic circuits perpendicular to the axis of the transformer. The coils of copper wire  $EN$  and  $NH$ , shown in section, were first wound with the requisite number of turns

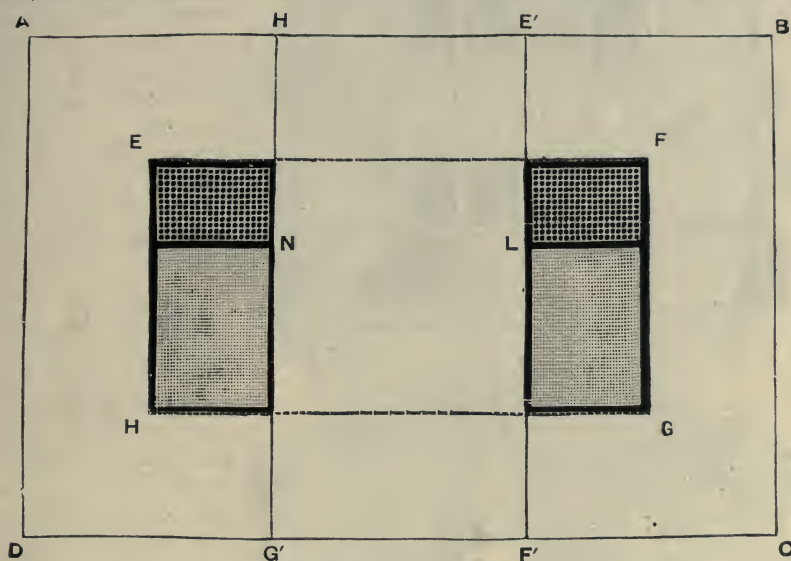

Fig. 402.—Mordey's Transformer (Section).

and carefully insulated from one another. Then the rectangle  $ABCD$ , which consists of a thin piece of iron, had the inner rectangle  $EFGH$  stamped out of it and the rectangular piece removed from the opening covered on one side with paper for insulation. A sufficient number of these large and small rectangles were then threaded alternately over and through the coils, and were finally clamped firmly in their places by the mechanical arrangements which are shown in Fig. 401. The transformer could of course be used in any position which was convenient.

The following figures and dimensions refer to a transformer designed to transform a current of 1.5 amperes at 1,000 volts to a current of 37.5 amperes at 40 volts. The primary coil consisted of 300 turns of copper wire 0.035 inch in diameter, with a resistance of 10 ohms; the secondary coil had

twelve turns of 25 wires, each 0.12 inch in diameter, joined in parallel, giving a resistance of 0.014 ohm. The weight of copper used was about 5 lbs. in the primary and 5½ lbs. in the secondary coil, and the weight of the iron was about 50 lbs. The transformer was 20 inches long, 6 inches high, and 4

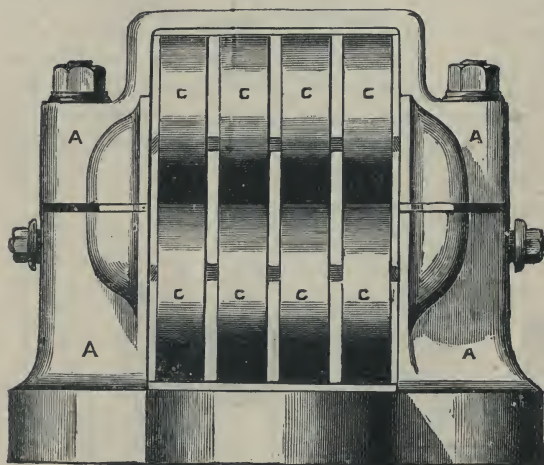

Fig. 403.—Ferranti Transformer (End View).

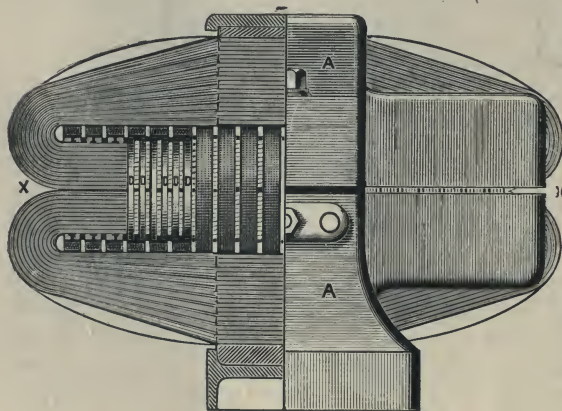

Fig. 404.—Ferranti Transformer (Side View and Section).

inches wide, and had an efficiency of 97.2 per cent. at full load. It should be carefully noted that in the example given the *thin* wire coil was used as the *primary* and the *thick* wire coil as the *secondary*. The induction coil was, in fact, used as a "step-down" transformer.

One of the pioneer enterprises in the distribution of electric energy by alternate currents was the great Deptford station, erected under the guidance of Mr. Ferranti in 1890. We shall have occasion to allude to this station again; at present it will be interesting to refer to the transformers used, which were called upon to withstand higher pressures than had been anywhere previously employed in engineering work. These transformers, as well as

the more massive parts of the plant, were designed by Mr. Ferranti. The general type is illustrated in Figs. 403 and 404, of which the former shows the outside appearance as seen from the end, and the latter is a side view, half of it in section, showing the arrangement of the coils and the magnetic circuit. The magnetic circuit consists of thin bands



of soft hoop-iron lightly insulated from one another; these were first arranged in straight bundles and the copper coils, wound on formers, were slipped over them. The hoop-iron was then bent over as at *x* (Fig. 404), and the ends from the right and left brought back to the centre, both top and bottom, where they overlapped and were clamped tightly together by the massive frames *A A*, as shown in Fig. 403, where *c c c* are the iron bands. Returning to the copper coils, of these the thick wire coils *D D D* (Fig. 404) were placed next to the central core, and the fine wire coils were wound outside them. All the coils were wound in small sections, which were carefully insulated from one another.

Fig. 405 shows a larger Ferranti transformer as used in the sub-stations in London to transform down 150 horse-power from 10,000 to 2,400 volts for the supply of a circumscribed area at the latter pressure. In this trans-

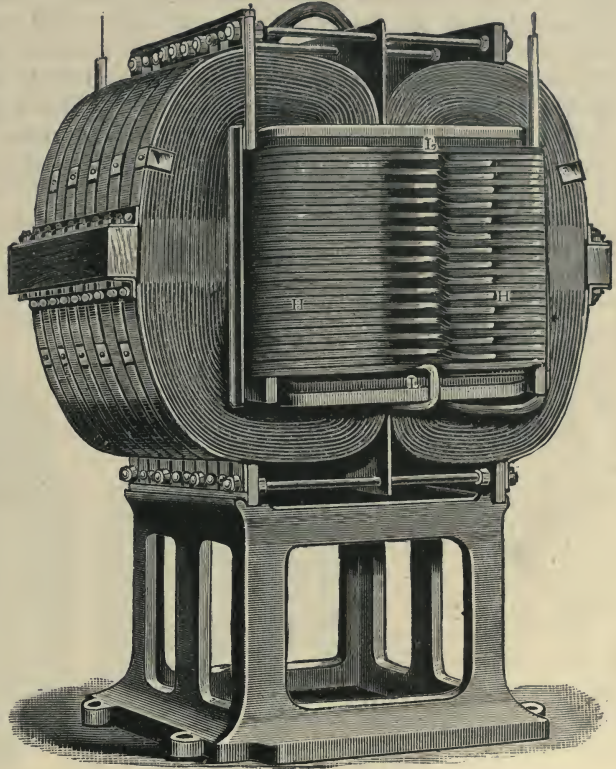

Fig. 405.—Ferranti 150 Horse Power Sub-Station Transformer.

former the high-pressure coils *H H* were sandwiched in between two sets *L L* of low-pressure coils. Each coil was made of copper strip separated with vulcanised fibre and overwound with shellac cloth and vulcanised fibre. A number of these flat coils were slipped over the straight lengths of hoop-iron as already described, and were separated from one another by layers of insulating material. The coils of each set were connected in series, and the low-pressure coils were separated from the high-pressure ones by sheets of ebonite and by an air space. The iron bands forming the magnetic circuit

were bent round to overlap as shown, and there were air spaces of half an inch between adjacent sets of bands. When in use the transformer was immersed in insulating oil, which diminished the risk of discharge between the high-pressure coil and the frame or the low-pressure coil ; the various spaces provided free circulation for the oil.

Many other patterns of transformers were produced at or about the same time as those selected for description, but the examples already cited will be sufficient to give the reader a preliminary idea of the great variety both in form and size adopted by designers of this particular piece of electrical apparatus. And this is not surprising, for the theoretical conditions to be fulfilled are simplicity itself. All that is wanted is two conducting electric circuits traversed by the same magnetic circuit, and these conditions can be satisfied in an almost infinite number of ways. There is therefore plenty of scope left for satisfying the further conditions which tend in the direction of high efficiency, and especially the absolutely essential condition of good insulation.

## CHAPTER XII.

## THE TELEPHONE.

WE are now in a position to resume our consideration of the application of the magnetic effects of the electric current, and we select next Electric Telephony, in which magneto-electric induction plays an important part, and which was not the least of the wonderful electrical developments of the last decades of the nineteenth century.

## I.—HISTORICAL NOTES.

**Reis's Telephone.**—It was discovered by Page, in 1837, that an iron bar, when magnetised and demagnetised at short intervals, emits

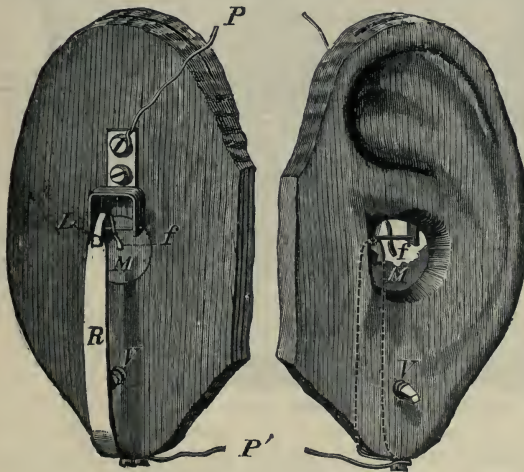

Fig. 406.—Reis's Telephone.

sounds; and on the basis of this experiment Philip Reis constructed his first electric telephone, or apparatus for the transmission of articulated speech to a distance by electrical means. Philip Reis was born on the 7th of January, 1834; he received a good elementary education, and entered a business-house when sixteen years of age, but for some years devoted his leisure time to the study of mathematics, chemistry, and physics, attending lectures delivered at the

commercial institute. He left business, however, and entered Dr. Poppe's establishment at Frankfurt, to qualify himself for a teacher. The first apparatus made by Reis, according to Dr. Messel, consisted of a beer-barrel, in the bung-hole of which a small cone was placed, covered at its smaller end with an animal membrane, upon which a small platinum strip or wire was fastened by means of sealing-wax. The



receiver consisted of a violin, upon which a knitting-needle, having a coil wound round it, was fastened. The transmitter was afterwards made in the form of the human ear (Fig. 406). Here the platinum wire *f* was fastened to the membrane *m* by means of sealing-wax, and a platinum contact *L*, fixed to the spring *R*, was placed opposite *f*. A screw *v* adjusted the spring. The wires *P P'* connected the apparatus with the battery. When sound-waves made the membrane *m* vibrate, the circuit *P f L R* and *P'* was made when *f* and *L* touched each other, and broken when

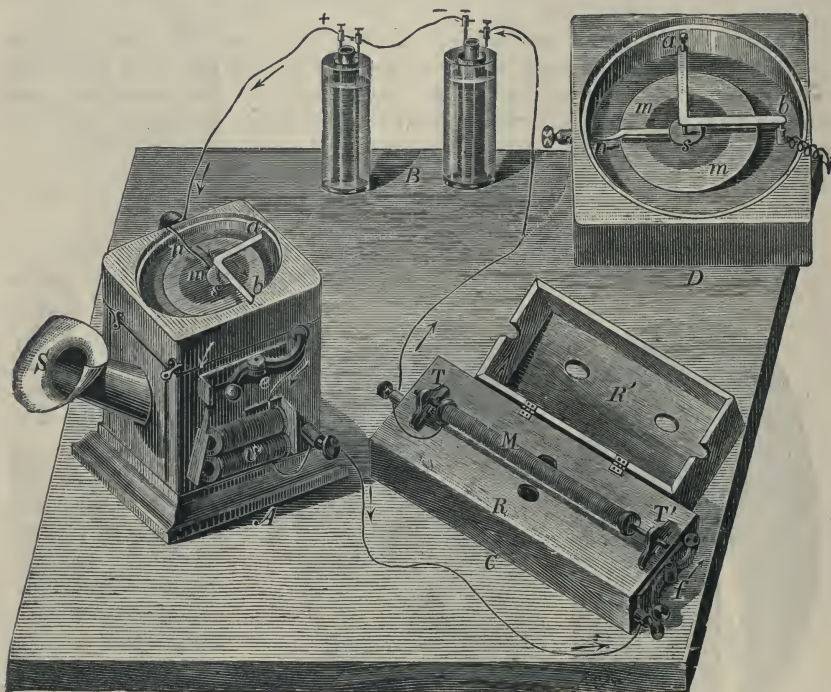

Fig. 407.—Reis's Telephone.

they parted. A later modification of the apparatus is shown in Fig. 407. It consists of three parts, A (the sender or transmitter), B (the battery), C (the receiver). These three portions are connected with each other by means of wires. The upper portion of A is shown separately at D, where *m m* is the tympanum of stretched membrane, having attached to it the platinum strip *s*. When the membrane vibrates, in response to the impulses of sound, this elastic strip of platinum beats to and fro against a tip of metal, altering the degree of contact at each vibration. The angular piece *a b*, which carries the contact-tip, is made of brass, and dips

at *b* into the mercury-cup, to which the battery wire is brought; the receiver *c* consists of an iron needle, 8·5 inches long and 0·036 inch thick, round which the coil *m* is wound. The rapid magnetisation and demagnetisation of this iron wire produced sounds having the same frequency, and therefore the same pitch, as the note sung into the transmitter. Reis showed his apparatus for the first time to the Physical Society of Frankfurt in 1861. Much has been said and written as to whether Reis's telephone was capable of transmitting words, or sounds only. That it transmitted words is proved by a letter which Reis wrote to F. J. Pisko, from which we translate the following extract:— "The apparatus gives whole melodies in any part of the scale between *C* and *c*" well, and I assure you, if you will come and see me here, I will show you that words also can be made out." Reis was well aware of the importance of his invention, which, at that time, was treated as a toy. He remarked to Garnier "that he had shown to the world a road to a great discovery, but left it to others to follow it up." Reis died in 1874.

Although the priority of the German inventor, Philip Reis, cannot be disputed, Reis's telephone had to undergo many modifications before it could be utilised for practical purposes. S. Yeates (1865), Wright (1865), C. Varley (1877), C. and L. Wray (1876), E. Gray (1874), Van Der Weyde, and Pollard and Garnier, all worked at the problem of bringing the telephone into a practical shape. Pollard and Garnier, and later Janssen, devised transmitters in which the microphone was almost anticipated, but their receivers were electrostatic condensers. Their apparatus will be found described in the earlier editions of this book.

The workers who were ultimately most successful were Bell in America and Hughes in England. The experiments of the former led up to the invention of the magneto-receiver, whilst those of the latter resulted in the microphone transmitter; the early experiments which produced these important results are therefore of great historical interest.

**Bell's Early Experiments.**—Mr. Graham Bell's early telephonic experiments were suggested by his professional work as a teacher of the deaf and dumb, in connection with which he came to Boston in 1868. The deaf and dumb are not, as a rule, unable to speak because their organs of speech are defective, but because, in consequence of their deafness, they cannot hear the spoken word, and consequently cannot imitate it; it is, therefore, usual to teach them to speak through other agents than the ear. For the further development of this method, Graham Bell and his father, Alexander Melville Bell, studied the mechanism of the voice. Graham Bell produced vowels artificially by means of tuning-forks, and, aided by Helmholtz's investigations (1859-1862), he made use of the electric current for his experiments. The first form of Bell's telephone is shown in Fig. 408. A reed harmonica *h h'* is fastened to the poles

of the permanent magnet  $N S$ , and between  $H$  and  $H'$  a coil of wire, surrounding a soft iron core, is placed. An exactly similar instrument is formed of a second permanent magnet  $n s$ , and the ends of the two coils  $E$  and  $e$  are connected either by two lines or by one line wire  $l$  and the earth  $L L'$ . When any one of the reeds  $H$

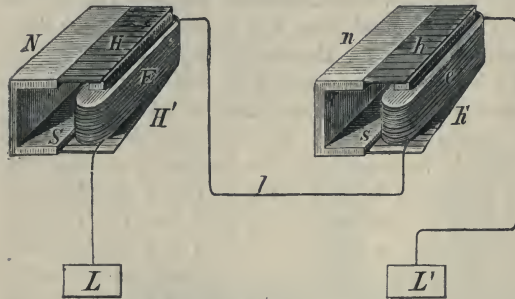

Fig. 408.—Bell's Electric Harmonica.

is made to vibrate—that is to say, to approach or recede from the core  $E$ —it will strengthen and then weaken the magnetic lines through the core  $E$ , and, as a consequence, currents will be

induced in the coils of the electro-magnet  $E$ . The currents will flow through the coil of the second electro-magnet  $e$ , connected by means of the wire  $l$  and the earth-plates  $L L'$  with the first. According to the

laws of resonance, one of the reeds  $h$  upon the permanent magnet  $n s$  will be attracted and repelled, *i.e.* will also begin to vibrate; for the impulses which the electro-magnet  $e$  receives are exactly the same as those induced in  $E$  through the vibrating of the reed which has been struck. Further, each reed can only produce that vibration peculiar to it, and of the reeds in  $h$  only that one will respond to the impulses, and continue to vibrate, whose natural rate of vibration synchronises with the rate of vibration

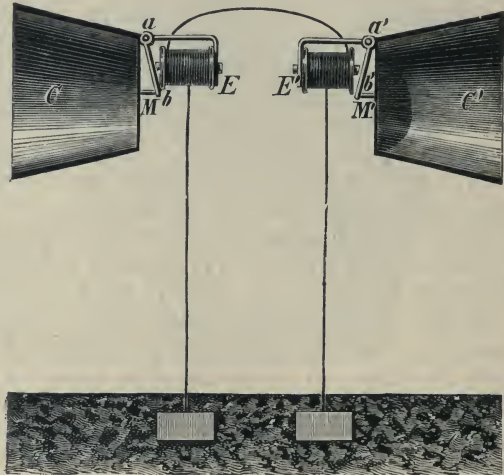

Fig. 409.—Bell's Second Telephone.

of the reed in  $H$ . If each reed of  $H$  be struck in succession, the reeds in  $h$ , which are in unison with those of  $H$ , will sound in succession; and if a tune be played on the reeds of  $H$ , the same tune will be heard from  $h$ . With accurately tuned reeds the transmission will be perfect, but the great expense of a complete piece of apparatus of this kind pre-



vented Bell from developing and perfecting it. Moreover, it is only available for the transmission of musical notes and cannot transmit articulate speech.

The next apparatus that Bell constructed is shown in Fig. 409. The cone  $c$  had its smaller opening closed by means of a gold-leaf  $m$ , which was connected by means of a little rod with the armature  $a b$  of the electro-magnet  $E$ . The cone  $c'$ , exactly similar to the first, was fitted in a similar manner with membrane  $m'$  and electro-magnet  $E'$ . When the membrane  $m$ , excited by sound-waves, began to vibrate, the armature, which vibrated along with it, induced undulating currents in the coils of the electro-magnet  $E$ , which caused similar vibrations on the membrane

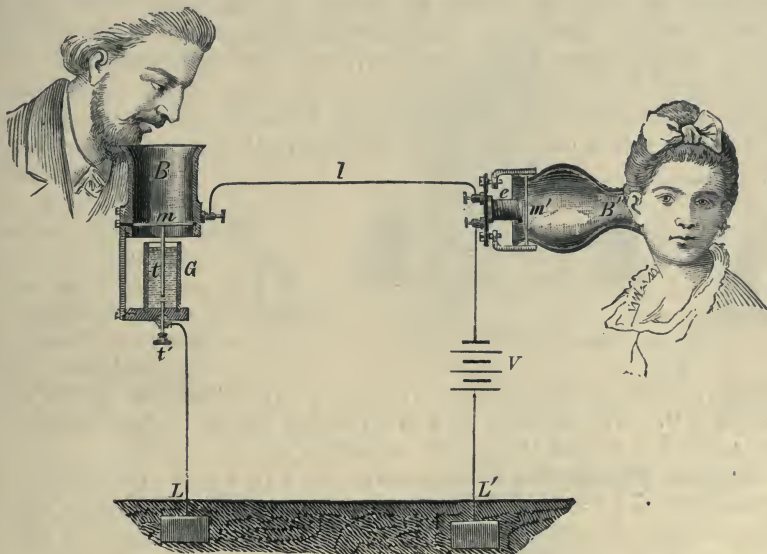

Fig. 410.—Gray's Telephone.

$m'$  by means of the magnet  $E'$ , and its armature  $a' b'$ . Bell took out a patent for this form of apparatus on the 14th of January, 1876, but it is unlikely that articulate speech was ever satisfactorily transmitted with this arrangement, though it was a long step in advance of the Electric Harmonica. Later in the same year Bell brought out his well-known magneto-telephone, which even in its early form practically solved the problem. This instrument we shall describe presently.

**Early Microphone Experiments.**—Before dealing with Hughes' work some earlier experiments by Elisha Gray and Berliner deserve notice.

In Gray's telephone, shown in Fig. 410, the transmitter and receiver are different. The former, when disturbed by the impact of the sound-

waves, is arranged to vary the resistance of a battery circuit. It consists of a box or mouthpiece  $B$ , the lower end of which is closed by a membrane  $m$ , which carries on its lower side a metal rod  $t$  in line with the screw  $t'$ . The rod  $t$  passes into a vessel  $G$ , which is filled with a badly conducting liquid. The receiver consists of the vessel  $B'$ , which is closed at one side by the membrane  $m'$ . The membrane has a piece of soft iron attached to it in the middle, and opposite to this is placed the electro-magnet  $e$ . The two parts of the apparatus are connected with each other by means of the wire  $l$  and the earth-plates  $L L'$ , and are inserted into the circuit of a battery  $v$ . The membrane, which is made to vibrate by speaking, inserts by means of the rod  $t$  more or less resistance in the circuit, producing pulsating currents, which are conveyed to the electro-magnet of the receiver, and cause the membrane  $m'$  to vibrate similarly to the membrane  $m$ .

Fig. 411 represents a microphone for which E. Berliner, of Boston, took out a patent on the 7th of July, 1877. The apparatus at the

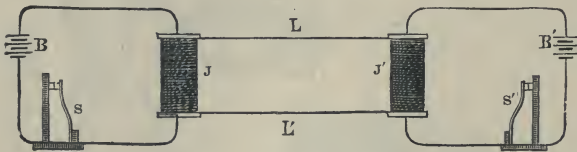

Fig. 411.—Berliner's Transmitter.

receiving and sending stations is similar in construction, and each consists of a battery, an induction coil, and carbon contacts, to form a microphone. The

secondary wires of the induction coils  $J J'$  are connected by the conductors  $L L'$ . The primary coils are inserted in the circuits containing the batteries  $B B'$ , and the carbon contacts  $s s'$ .

**Hughes' Microphone Experiments.**—We turn now to the important investigations of Professor D. E. Hughes, which he made known to the Royal Society of London in 1878. The aim of his investigations was to find a method of altering the resistance of an electric circuit in such a manner as would be useful for the electric transmission of speech. Any such arrangement he called a *microphone*, a word which we have already used in this sense. In one set of experiments he took a glass tube of about three inches in length filled with bronze powder, and closed the ends by means of retort coke, so that the metal powder was pressed gently together. The wires fastened to the carbon plugs formed a closed circuit with a battery and a galvanometer. When a pressure or pull with both hands was exerted on the tube the galvanometer needle showed a great change in its deflection. The tube proved convenient for producing a simple telephonic apparatus. For this purpose the tube was placed upon a resonance box (Fig. 412), the plug  $y$  was connected with a battery  $B$ , and the plug  $x$  with a Bell telephone  $T$ . Words spoken into the resonance box could be heard distinctly in the telephone  $T$  placed at

various distances. The same results were obtained when, instead of the glass tube, a rod of charcoal was taken, which had been previously brought to white heat and then dipped in mercury. A still simpler arrangement tried by Hughes is that shown in Fig. 413. It consists of two wire pins or French nails placed parallel to each other, and a third one simply laid across them; the pins *x* and *y* are joined in the circuit. In this arrangement the contacts of the cross-pin with the pins underneath form the changeable resistance which brings about the microphonic effects.

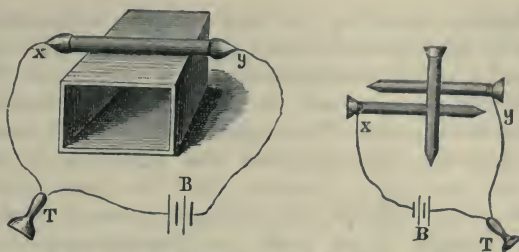

Fig. 412.—Hughes' Microphones without Carbon.—Fig. 413.

Microphones of greater sensibility are shown in Figs. 414 and 415. Upon the platform *D*, Fig. 414, a resonance board is fastened vertically, and made to carry two carbon blocks *c c*, between which the carbon rod *A* is loosely held. The wires *xy* are fastened to the carbons *c c*. To experiment with this microphone, it is placed upon cotton-wool, or upon two pieces of indiarubber tubing. The wires *xy* are connected with a Bell telephone, and a

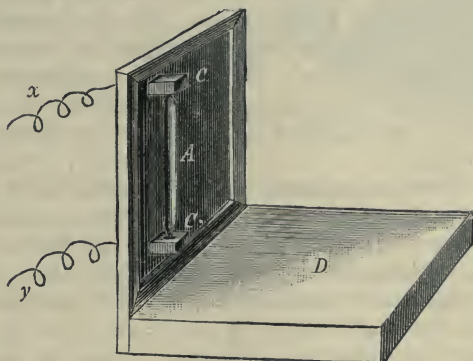

Fig. 414.

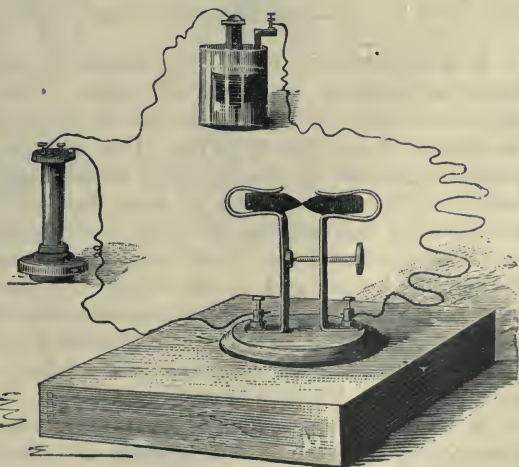

Fig. 415.—Hughes' Carbon Microphones.



battery consisting of one to two Leclanché or three Daniell cells. The vibrations of sound, when conveyed to the points of contact of *c c* and *A*, either directly, by the air, or through the board, alter the resistances at these points, and so strengthen and weaken the current alternately for every pulse. The changes of current affect the magnet of the distant telephone, and reproduce the vibrations in the telephonic plate. The instrument is so sensitive that the tramp of a fly walking across *D* can be heard through the telephone. Words spoken even at a distance of from eight to ten yards from the microphone are distinctly heard. As the efficiency of a microphone is greatly dependent upon the kind of contact, it is advantageous to make the latter so that it can be regulated. This Hughes brought about, in the manner shown in Fig. 415. To ascertain the most effective position of the two carbons with regard to each other, a watch, for instance, is placed upon the sounding-box of the microphone; the ticking is observed through the telephone, and the two carbons are regulated by means of the screws until the best effects are obtained.

These experiments of Hughes revealed to the world the extreme simplicity of the conditions necessary for successful microphonic action. The discoverer applied for no patent, but presented the discovery freely to his contemporaries; the result was that within a short time many applications of modifications embodied in more or less suitable instruments were patented. Some of the more important of these we shall describe after discussing the elementary principles involved in the electric transmission of speech to a distance.

## II.—THE ELECTRIC TRANSMISSION OF SPEECH.

It is well known that audible sounds are transmitted through the air from the source to the hearer by means of disturbances of the intervening air particles, these disturbances being propagated from one particle to another in a series of waves. That the air is necessary for the transmission is proved by the fact that sounds cannot be propagated across a vacuum. The place of the air may, however, be taken by any material body having the requisite elasticity, and a very old form of mechanical telephone known as the "lover's telephone" uses a stretched string for the purpose. Each end of the string is fastened to the middle of the bottom of a cardboard box—for instance, a pill-box will serve admirably—and if the string be stretched moderately taut words whispered into one box can be heard distinctly in the other, though the string be 100 or more feet in length.

In these and similar cases the particles of the material body or medium transmitting the sounds are capable of vibrating in obedience to the impulses impressed upon them, however complicated those impulses may

be. In all articulate speech the sound waves are of an exceedingly complicated character, so much so that the more the complicated character of the waves is examined the greater appears the improbability of being able to reproduce these complications in an electric current. One of the simplest ways of examining the character of the disturbances which constitute sound is to experiment with thin discs of various materials. The vibrations of thin discs under the influence of sounds can be made optically visible in many ways. One method is to stretch an indiarubber membrane over the end of a speaking-tube, with a small mirror cemented in the centre: on singing into the tube a spot of light reflected from the mirror will describe on a screen the most extraordinary figures, whilst a musical note gives a much simpler disturbance than a spoken word.

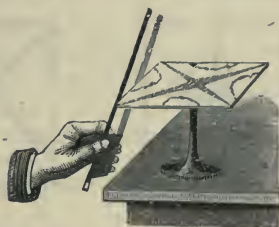

Fig. 416.—Production of Acoustic Sand Figures.

The subject of the vibrations of plates was very exhaustively examined by Chladni during the latter part of the 18th century. In one series of experiments he used the simple method of supporting the plate to be examined in the centre with its plane horizontal and sprinkling fine sand upon it. The plate was set in vibration by drawing a violin bow across its edge (Fig. 416), when the sand was

thrown off the middle of the vibrating sections and accumulated in the nodal portions — that is, those portions in which the motion is least. According to the method adopted for setting the plate in vibration the figures produced are either simple or

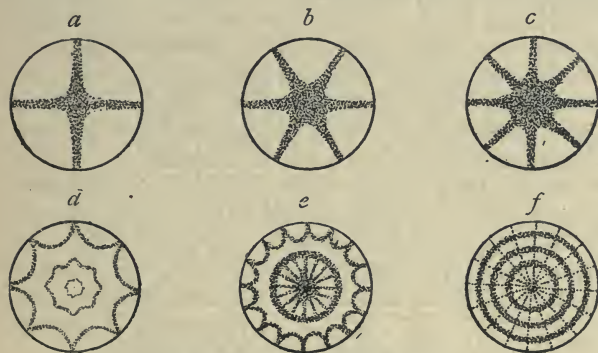

Fig. 417.—Vibrations of Circular Plates.

complicated. Fig. 417 shows the sand patterns obtained in the case of a circular plate set in vibration in different ways. The plain cross *a* is produced when the plate is sounding its fundamental note. The more complicated crosses and figures are produced by different methods of starting the vibrations in which overtones of different orders are produced. Fig. 418 gives three patterns obtained with square plates; in *a* the plate is giving its fundamental or lowest note, in *b* the fifth of the fundamental, and in *c*

still higher notes. In Fig. 419 still more extensive experiments upon square plates are illustrated. In this figure the square plate is shown under no fewer than 70 different vibrating conditions. The patterns on the left-hand vertical row and in the bottom horizontal row are all independent; the other patterns are produced by combining two of these, one from

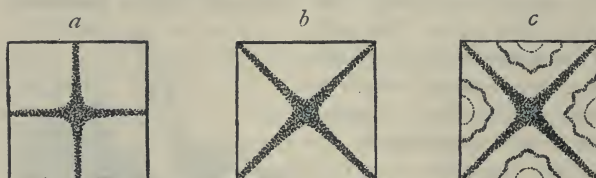

Fig. 418.—Simple Vibrations of Square Plates.

each series; thus any pattern in the remainder of the diagram is formed by combining the two opposite which it appears. All the patterns are fairly regular and correspond to the emission of musical notes by the plate, some of these notes being of high pitch. The most complicated of them, however, is simplicity itself as compared with what would be, the corresponding pattern, if it could be produced in this way, which would be given by

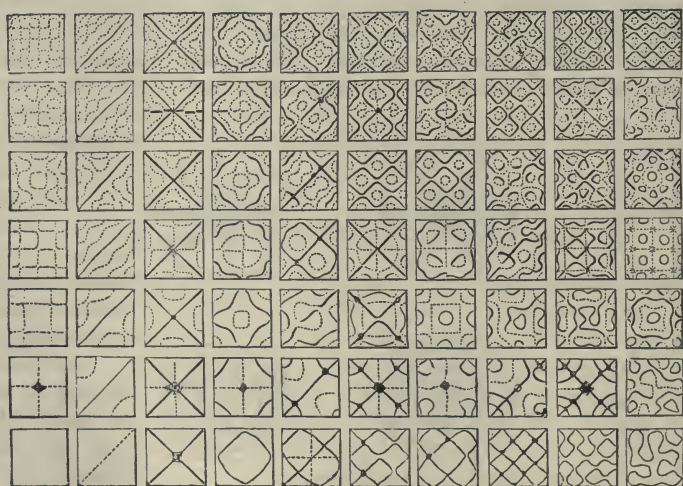

Fig. 419.—Chladni's Figures for a Square Plate.

the plate when vibrating in accordance with the disturbances set up by articulate speech.

A still more beautiful method of analysing the vibrations, and one applicable to articulate speech, consists in placing across the end of a speaking-tube a plate pierced by a hole 1 to 1.5 inch in diameter, closed by a soap-film. On singing into the tube, all the vibrations can be seen in the



film, producing the most intricate and complicated figures, which change with every note. Such an instrument is called a Phoneidoscope. Its figures may be readily projected upon a screen with the aid of a lantern, or may be seen with the naked eye in the film itself, and give a vivid idea of the complicated vibrations which take place in a thin plate under the influence of comparatively simple sounds.

The main problem in the electric transmission of sound is either to produce a varying electric current whose variations shall follow faithfully every variation of the most complex sound or to impress these variations upon an already existing current. Solutions have been found by both of these methods. In the first case the currents used are *alternate currents*—that is, they are being continually reversed, being alternately in one direction and in the opposite direction. The alternations are not simple, however, but must partake of all the complexities of the sound waves. In the second case the currents used are *pulsating currents*—that is, the currents are all in one direction and never reverse, but are sometimes stronger and sometimes weaker than the average or mean value. Here again, however, the changes in strength must follow all the complexities of the sound waves if the transmission is to be successful. If represented by a curve in which the current strength is plotted vertically and the time intervals are plotted horizontally the curve would be more complex than a corresponding curve which should represent the varying height, above some arbitrary datum line, of a particle of water on the surface of the ocean when the latter is being lashed by a severe storm.

Now, according to Ohm's law, there are two distinct ways in which an electric current can be made to vary—(a) by varying the E. M. F. and (b) by varying the resistance in the circuit. Bell adopted the first method, making use of the principles of magneto-electric induction (see pages 445 to 447) to generate in the circuit a varying E. M. F. of the necessary complexity. Under the conditions this E. M. F. must be an alternate E. M. F., for the addition of magnetic lines to a circuit cannot be carried on to an infinite extent, and there must be a reversal sooner or later. The currents used by Bell were therefore alternate currents, and, as we shall see presently, his instruments are reversible—that is, can act as receivers as well as transmitters.

The second method of varying the current by altering the resistance in the circuit is made use of in the microphone. It gives rise to pulsating currents, since, unless a current is already in the circuit, no change of resistance can generate a current. This method is irreversible—that is, the instruments can only act as transmitters and not as receivers.

## III.—MAGNETO-TELEPHONES.

**Bell's Telephone.**—The ultimate form which Bell gave to his first successful telephone is shown in Fig. 420. A well-magnetised bar magnet

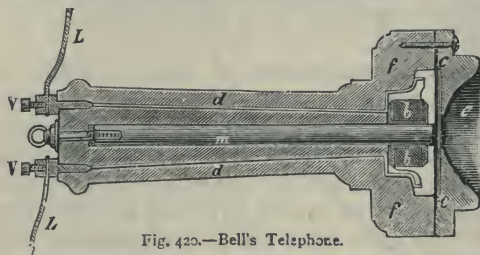

Fig. 420.—Bell's Telephone.

*m* is encased in a wooden frame *f f*, and its end surrounded by a fine wire coil *b b*. The ends of the coil are soldered to thick copper wires *d d*, which terminate in the clamps *v v*. The hollow in *f f* is closed by an iron disc *c c* clamped in its place by a mouthpiece *e* of

the shape shown. The distance of *m* from the thin iron disc *c c* can be regulated by means of the screw shown at the end of the instrument between the terminals. The sheet of iron has that side which can be seen from *e* coated with varnish or tin to prevent oxidisation being caused by the moisture in the breath of the speaker. The diameter and length of the wire for the coil must be determined by the resistance which exists in the remainder of the circuit of the telephone. The instrument acts best

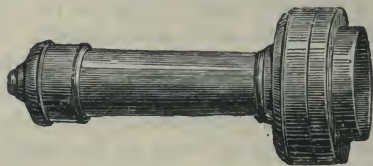

Fig. 421.—Bell's Telephone

when the magnet is powerful and the turns of the coil are numerous, and when the iron disc is placed very near to the magnet. This distance has, however, to be arranged so that the disc, even in its most violent

vibrations, does not come in contact with the magnet. For convenience in the handling of the instrument, the clamps *v v* were, as a rule, covered as shown in Fig. 421. The mouthpiece *e* collects and concentrates the voice.

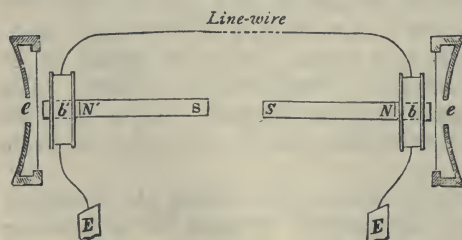

Fig. 422.—Diagram of Transmitter and Receiver.

Bell's telephone may be used both as a receiver and a transmitter. Fig. 422 represents diagrammatically two Bell telephones which are exactly alike, each of which may be used either as a receiver or as a transmitter; *b b'* represent the coils, *N S* and *N' S'* the magnets, and *e e* the speaking-funnels with the iron discs. The ends of the coils are connected with the earth-plates *E E* on the one side and with the line on the other.

In order to make clear the action of the instrument as a transmitter, it will be well to recapitulate briefly here, in a slightly different form, the principles underlying the laws of magneto-electric induction, which are more fully described elsewhere (page 416 *et seq.*). When a conductor forming part of a closed circuit is moved across the lines of force in a magnetic field, a current of electricity is generated whose strength depends upon the velocity of motion of the conductor and upon the intensity of the magnetic field. Conversely, when lines of force are projected through a closed conducting circuit (see Fig. 385) a current of electricity is generated in that conductor, whose strength depends upon the rate of change of those lines of force. In other words, when a closed circuit moves in a magnetic field so that the number of lines of force passing through the circuit is altered, then an E. M. F. is generated in the circuit which produces a corresponding current in the circuit; and, conversely, when the closed circuit is stationary, but the field either moves or alters its form so that the number of lines of force projected through the circuit alters, then also an E. M. F. and consequently a current are generated in the circuit. The direction of the current is given by Lenz' law, viz., that the current produced tends to resist the motion producing it. Faraday's law which asserts that the form and duration of the current is dependent upon the rate and duration of the motion of the lines of force is the principle of the magneto-telephone.

Let *N S* (Fig. 423) be a permanent magnet, and *a b* a fixed closed conducting ring of copper wire around one pole of the magnet. Let *c* be the central portion of a movable iron armature. Now if we regard any two lines of force, *F I F I*, radiating from the pole *N*, and nearly cutting the ring *a b*, then, as we make *c* approach or recede from *N*, those lines of magnetic force will change their direction, taking up position 2, say, when the plate *c* moves into the position *c*. With each change of direction they will cut the ring *a b*, and currents of electricity in different directions will circulate through *a b* according to the direction of motion of the lines of force; and the rate of increase and decrease of the number of the lines of force passing through the circuit will vary directly with the rate of motion of the armature *c* to or from the pole *N*. Thus if *c* be a disc of iron vibrating under the influence of sound, the excursions to and fro of any point of the disc, though very small, are nevertheless sufficient to produce that motion of the lines of force which results in currents. It bends the lines of force cutting *a b*, and thereby produces in the ring *a b* undulating currents of electricity whose number depends on the number of vibrations, and whose form and intensity depend on the rate and amplitude of motion of the disc *c*.

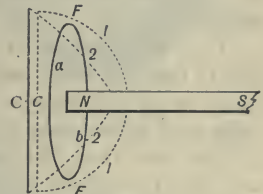

Fig. 423.—Theory of the Bell Telephone.



These currents are alternating and very rapid; that the motion of the disc can produce currents may be readily shown by a Thomson's reflecting galvanometer, when the disc is gently and slowly pressed in by the finger—in one direction when the disc is pressed in, and in the other when it is allowed to spring back again.

It will now be understood that when the sheet-iron disc of a telephone is made to vibrate by speaking into it, the position of the sheet as regards the magnet will be continually changing; but the changes between magnet and sheet cause corresponding changes in the magnetic flux in the medium surrounding them. The magnet is surrounded by a coil  $\delta$  (Fig. 422), which is connected with a similar coil  $\delta'$  in the same circuit. The current impulses produced in the coil  $\delta$  through the alteration of the magnetic flux of  $N S$  (or rather of the shape of the lines of force between  $N$  and the disc, whereby a larger or smaller number pass through  $\delta$ ) will, therefore, be conveyed through the whole circuit, and will appear at the receiving station in the coil  $\delta'$ —hence the iron sheet at the receiving station will vibrate, and as a matter of fact copy with remarkable fidelity the sound-waves at the sending station.

It is usually said, as above, that the sounds heard in the receiver are due to the iron sheet being set in vibration by the variation in the attraction upon it of the magnet  $N S$ . That some of the action may be thus explained is probable, but that this is not the whole explanation is proved by the fact that Reis' knitting-needle receiver (*see* page 444) will work, and that therefore a receiver can be made without any magnetic diaphragm. These and other experiments tend to show that some of the action, if not the greater part of it, is molecular and not molar only.

Numerous attempts were made to improve the Bell telephone very shortly after its invention. Many of these were in the direction of improving the magnetic circuit, more particularly by using double pole instruments in which only a short portion of the magnetic circuit lies through non-magnetic material. The magnet in the original Bell telephone (Fig. 420) is a simple bar magnet, the lines of which have a comparatively long return path. It seemed natural to suppose that with a more perfect magnetic circuit better effects would be secured. There is certainly some improvement, but not nearly so much as might reasonably have been expected in view of the above-described theories of the action of the instrument.

Double pole instruments, designed by Bell himself, by Siemens, by Fein, and others, will be found described in the earlier editions of this book. We select for description here two forms, each of which, when first introduced, was a distinct improvement on existing forms. They will be sufficient for our present purpose, which is mainly historical.

**Gower's telephone**, which was thought highly of because of its effects, which were considered powerful at the time, is shown in Fig. 424. The horseshoe magnet  $N O S$  was bent into a semicircle, and the end of its arms

were bent at right angles to the plane of the magnet. The magnet formed in this manner was very powerful, and, according to Th. du Moncel, capable of carrying a weight of eleven pounds. The bent portions carried the oval-shaped coils. The ends of the coils were connected with clamps that were fastened to the outside of the metal box enclosing the apparatus. The sheet of iron *e* was larger and made of stronger material than was generally used for earlier telephones. The signalling apparatus consisted of the tube *a*, bent towards the iron sheet, inside which a small



Fig. 424. —Gower's Telephone.

vibrating tongue was placed : this could be agitated by blowing into the flexible tube, through the mouthpiece fastened to the back of the case, thus producing a loud sound close to the disc and causing the latter to vibrate violently.

**Ader's Telephone.**—Cl. Ader constructed an effective telephone by making use of the principle that an iron plate inserted between a magnetic pole and its armature is affected inductively as if it formed part of the armature. The more massive the armature the more readily do the lines of force pass through it in preference to passing through the air, and the interposed iron plate increases the effective magnetic mass of the armature.

Now in the Ader telephone, which is shown in plan and elevation, and also in section, in Fig. 425 the circular-shaped horseshoe magnet  $M$  had the coils  $s s$  surrounding the soft iron extensions of its poles, and opposite to these the iron diaphragm  $m m$  was placed. A ring of soft iron  $a a$  was placed inside the mouthpiece of the telephone, so as to form an additional and comparatively massive armature of the magnet. The thin iron sheet was placed between the magnet poles and this armature, and would therefore be exposed to strong magnetic influences. In fact, the lines of force, which,

if the massive iron ring  $a a$  were absent, would many of them stray across through the air between the poles of the horseshoe magnet without entering the plate  $m m$  at all, were by the presence of this better medium drawn through the plate. The magnetic field in which the plate moves thus becomes much more concentrated, and the fluctuations produced in this field by the vibratory movements of the plate develop in the coils  $s s$  stronger currents than would be produced without the assistance of the ring. Ader carefully rounded

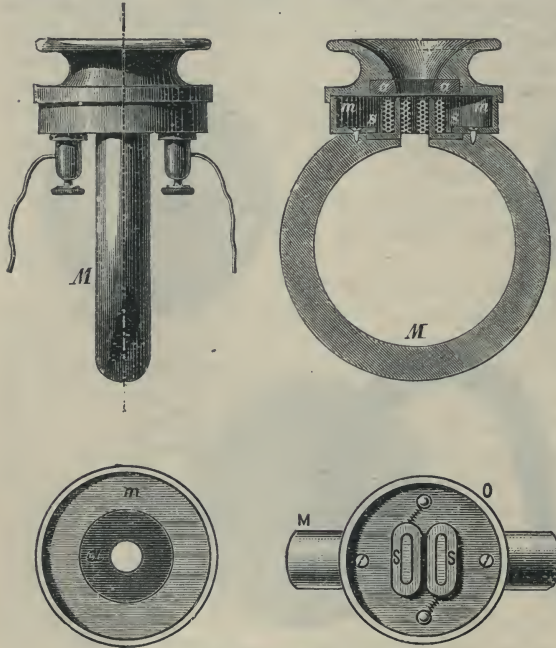

Fig. 425.—Ader's Telephone.

then plated it with nickel-silver to give to the apparatus a neat appearance and a convenient form.

**Gray's Telephone.**—Just as it has been attempted to increase the efficiency of telephones by increasing the number of magnets or magnet-poles, so also several vibrating plates independent of each other have been used. A telephone with two plates was constructed by Elisha Gray; it consisted, as shown in Fig. 426, of two telephones placed at an acute angle. The horseshoe magnet  $n m s$  had cylindrical pole-pieces  $\Lambda$ , which were surrounded by the coils  $b b$ . Each pole-piece had a sheet of iron opposite to it, but the speaking-tube  $e$ , which terminated in the tubes  $a$ , served for both membranes. The connection of the coils is



shown at *d*; *L L* is the lid that covered the disc. The idea of using double membranes has been revived in a recent very successful magneto-receiver.

We here conclude the description of magneto-telephones, especially as a comparison of many later inventions with Bell's instrument shows no noteworthy alteration, and very little improvement; for although some of the instruments described surpass Bell's instrument in effect, none of them has surpassed or even reached the soft and precise accentuation of it. Here, as in the construction of many machines, new constructions are frequently made simply to obtain new patents, without regard to improvement of effect. The efficiency of a telephone depends less upon the insignificant alterations of a designer than upon the careful and exact workmanship with which the parts must be fitted.

#### IV.—MICROPHONE TRANSMITTERS.

**Hughes' Experiments.**—We turn now to the second principal method of varying a current in a circuit, and cannot do better than preface our references to the more important historical forms of microphone transmitters by giving Professor Hughes' explanation of the action of the wonderful instrument of which he was the inventor. He states the problem he sought to solve by the microphone as follows: To introduce into an electrical circuit an electrical resistance, which resistance shall vary in exact accord with sonorous vibrations, so as to produce an undulatory current of electricity from a constant source, whose wave-length, height, and form shall be an exact representation of the sonorous waves. In the microphone we have an electric conducting material, susceptible of being influenced by sonorous vibrations; and thus we have the first step of the solution.

The second step is one of great importance, and was solved by the discovery that when an electric conductor in a divided state, either in the form of powder, filings, or surfaces, is put under a certain slight pressure, far less than that which would produce cohesion, but *more than would allow it to be separated by sonorous vibrations*, the following state of things occurs: The molecules at these surfaces being in a comparatively free state, although electrically joined, do of themselves so arrange their form, their number in contact, or their pressure, that the increase and decrease of the electrical resistance of the circuit is altered in a very remarkable manner, and to an extent that is almost fabulous.

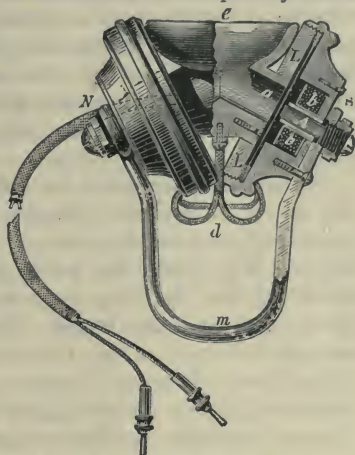

Fig. 426.—Gray's Telephone.

It is only necessary to observe certain general considerations to produce an endless variety, each having a special range of resistance. The tramp of a fly, or the cry of an insect, requires little range, but great sensitiveness; and two surfaces, therefore, of chosen materials, under a very slight pressure, such as the mere weight of a small superposed conductor (Figs. 412 and 413), suffice; but it would be unsuitable for a man's voice, as the vibrations produced by the voice would be too powerful for the instrument, and would, in fact, produce interruption of contact amounting to "make and break."

The simplest form of microphone employed by Professor Hughes in his theoretical investigations consisted of a flat piece of charcoal, 0.08 inch thick and 0.4 inch square, connected with a copper wire, and glued to a board or block of wood. Upon this piece one or more similar pieces were superposed, the upper piece being connected with a wire. The required pressure was put on the blocks. Professor Hughes thus reasoned out the nature of the molecular action:

"Let the lower piece be called A, and the upper B; when we subject the board to sonorous vibrations we cannot imagine in the charcoal an undulatory movement of the actual wave-length of the sonorous wave, for that would be several feet; nor can we imagine a wave of any length without admitting that the force must be transmitted from molecule to molecule throughout the entire length. How is it that the molecular action at the surfaces of A and B so vary the conductivity or electrical resistance as to throw it into waves in the exact form of the sonorous vibrations? It cannot be because it throws up the upper portion, making an intermittent current, because the upper portion is fastened to the lower, and the galvanometer does not indicate any interruption of current whatever. It cannot be because the molecules arrange themselves in stratified lines, becoming more or less conductive, as then surfaces would not be required, that is, we should not require discontinuity between the blocks A and B; nor would the upper surface be thrown up if the pressure be removed, as sand is on a vibrating glass. The throwing up of this upper piece B when pressure is removed proves that a blow, pressure, or upheaval of the lower portion takes place: that this takes place there cannot be any doubt, as the surface considered alone (having no depth) could not bodily quit its mass. In fact, there must have been a movement to a certain depth; and I am inclined to believe, from numerous experiments, that the whole block increases and diminishes in size at all points, in the centre as well as the surface, exactly in accordance with the form of the sonorous wave. Confining our attention, however, to points on A and B, how can this increased molecular size or form produce a change in the electrical waves? This may happen in two ways: *first*, by increased pressure on the upper surface, due to its enlargement; or, *second*, the molecules themselves, finding a certain resistance opposed to their upward movement, spread themselves, making innumerable fresh points of contact. Thus an undulatory current would appear to be produced by infinite change

in the number of fresh contacts. I am inclined to believe that both actions occur ; but the latter seems to me the true explanation ; for if the first were alone true, we should have a far greater effect from metal powder, carbon, or some elastic conductor, such as metalised silk, than from gold or other hard unoxidisable matter ; but as the best results as regards the human voice were obtained from two surfaces of solid gold, I am inclined to view with more favour the idea that an infinite variety of fresh contacts brought into play by the molecular pressure affords the true explanation. It has the advantage of being supported by the numerous forms of microphone I have constructed, in all of which I can fully trace the effect.

"I have been very much struck by the great mechanical force exerted by this uprising of the molecules under sonorous vibrations. With vibrations from a musical box 2 feet in length, I found that one ounce of lead was not sufficient on a surface of contact 0·4 of an inch square to maintain constant contact ; and it was only by removing the musical box to a distance of several feet that I was enabled to preserve continuity of current with a moderate pressure. I have spoken to forty microphones at once, and they all seem to respond with equal force. Of course, there must be a loss of energy in the conversion of molecular vibrations into electrical waves ; but it is so small that I have never been able to measure it with the simple appliances at my disposal. I have examined every portion of my room—wood, stone, metal, in fact all parts—and even a piece of indiarubber : all were in molecular movement whenever I spoke. As yet I have found no such insulator for sound as gutta-percha is for electricity. Caoutchouc seems to be the best ; but I have never been able by the use of any amount at my disposal to prevent the microphone reporting all it heard.

"The question of insulation has now become one of necessity, as the microphone has opened to us a world of sounds, of the existence of which we were unaware. If we can insulate the instrument so as to direct its powers on any single object, as on a moving fly, it will be possible to investigate that object undisturbed by the pandemonium of sounds which at present the microphone reveals where we thought complete silence prevailed.

"I have recently made the following curious observation : A microphone on a resonant board is placed in a battery circuit together with two telephones. When one of these is placed on the resonant board, a continuous sound will emanate from the other. The sound is started by the vibration which is imparted to the board when the telephone is placed on it ; this impulse, passing through the microphone, sets both telephone discs in motion ; and the instrument on the board, reacting through the microphone, causes a continuous sound to be produced, which is permanent so long as the independent current of electricity is maintained through the microphone. It follows that the question of providing a *relay* for the human voice in telephony is thus solved.



"The transmission of sound through the microphone is perfectly duplex; for if two correspondents use microphones as transmitters, and telephones as receivers, each can hear the other, but his own speech is inaudible: and if each sing a different note, no chord is heard. The experiments on the deaf have proved that they can be made to hear the tick of a watch, but not, as yet, human speech distinctly; and my results in this direction point to the conclusion that we only hear ourselves speak through the bones and not through the ears.

"However simple the microphone may appear at first glance, it has taken me many months of unremitting labour and study to bring it to its present state through the numerous forms, each suitable for a special object."

Professor Hughes throughout his investigations used a Bell telephone as receiver, and it was owing to the discovery of that sensitive instrument that he was able to follow up his researches.

**Simple Microphone Circuit.**—It will be gathered from the above and

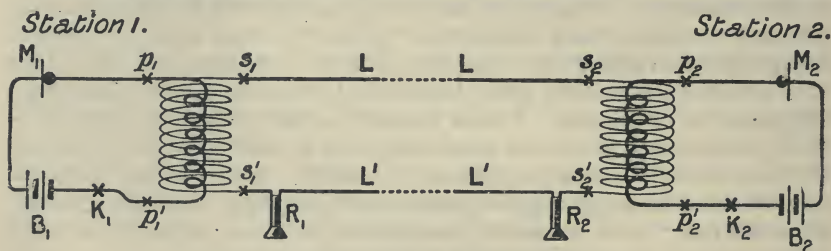

Fig. 427.—Telephone Circuit with Microphone Transmitters.

from what we have previously said that the fundamental principle of the microphone is the variation of the resistance of a loose contact in an electric circuit. In the sister science of telegraphy—and, indeed, in most if not all other applications of the electric current—such loose contacts are rigorously excluded, and may be described as the bane of electricians. The old proverb that "what is one man's meat is another man's poison" would appear to have a new and unexpected application here.

The connections for telephonic communication with microphone transmitters are not so simple as those we have depicted in Fig. 422 as being all that are necessary when magneto-telephones are used both as transmitters and receivers. In the first place, it is necessary to supply current to the microphones, and this is most simply done by having a small local battery  $B_1$  or  $B_2$  (Fig. 427) at each end of the line. Then, again, many of the microphones in use have a very low resistance, and, remembering that the effect desired is to be obtained by a *variation* only of this resistance, it is obvious that if the remaining resistance of the circuit be large, so that the whole microphone resistance is but a small fraction of the total resistance,

the variations in the microphone, being but a small fraction of a small fraction, will produce only an infinitesimal effect upon the current. Now, for reasons which we shall develop later it is necessary to use two line wires  $L L$  and  $L' L'$  between the distant places in telephonic communication, the earth not being available for the return circuit as in telegraphy. If the places, therefore, are fairly distant the resistance of the line wires alone must be many times that of the microphones, and therefore, for the reasons just given, they should not be included in the microphone circuit. The development of the microphone as a practical instrument would probably have been stopped by this difficulty had it not been for the existence and properties of induction coils (*see* page 433). Let such a coil be wound with two circuits, one (the primary)  $p, p'$ , consisting of a few turns of thick wire of low resistance, and the other (the secondary)  $s, s'$ , of many turns of fine wire. If the primary coil  $p, p'$ , be now put in circuit with the microphone  $M$ , and the battery  $B$ , the variation of the resistance of  $M$ , when spoken to will cause pulsations in the current in the primary coils, and these pulsations will set up E. M. F.'s in *each* of the turns of the secondary coil. The total changes of pressure at the terminals  $s, s'$ , will therefore be many times the changes of P. D. at the terminals  $p, p'$ . These E. M. F.'s will generate the necessary currents through the circuit of the line wires  $L L$  and  $L' L'$  and the magneto-receivers  $R, R$ . The figure shows diagrammatically the two distant stations 1 and 2, and the corresponding points, etc., at the two stations are designated by the same letters with these numbers attached. Switches  $K, K$ , are always, in practice, inserted in the microphone circuit so as to break the circuit and prevent waste of energy when the apparatus is not in use. These switches are worked automatically by hanging up the receivers, an operation which usually breaks the battery circuit.

**Early Microphones.**—Of the numerous instruments which were invented in the early days of telephony we can only describe a few typical ones, which we hope, however, will be sufficient to indicate the main lines along which development has taken place.

One group of inventors, whose instruments were very widely used, closely followed one of Hughes' original experimental instruments (Fig. 414), which we have already described. All these employ carbon rods or pencils held loosely between carbon blocks fixed upon a pine board. The chief modifications consisted in multiplying the number of carbon rods, which were held in loose contact between the fixed carbon blocks, and in arranging the microphone contacts and the auxiliary apparatus in a convenient form. The best-known were designed by Crossley, Ader and Gower. All three make use of a rectangular strip of wood as a resonance board. This board, as a rule, is fastened in the opening of a strong wooden frame, forming with it a box, shaped in Crossley's instrument (Fig. 428), like a writing-desk, the inside of which contains the carbon contacts. These consist of four carbon rods, which rest with their ends upon carbon blocks, as shown;

electrically the arrangement is two in series and two parallel. The connection of the carbon contacts with the battery is brought about by

metal strips, fastened to the carbon blocks. Ader arranges eight or ten carbon rods (Fig. 429), being five rows in parallel, each consisting of two carbon pencils in series. Ader, who had undertaken the transmission of the opera-music to the Palace of Industry during the Exhibition in 1881, placed his microphones upon leaden plates *p*, in order to prevent interruption or disturbance, by footsteps on the floor, etc., of the music transmitted from the voice of the singer.

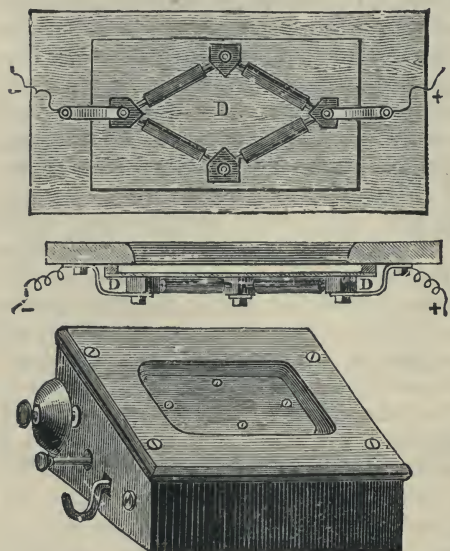

Fig. 428. — Crossley's Transmitter.

show the inside), which is placed over the remainder of the apparatus, arranged on a horizontal base. The form of microphone is one originally devised by Gower, and known as the Gower - Bell transmitter, but its details were modified and improved by the Post Office. It is, obviously, merely a special arrangement of Hughes' original microphone (Fig. 414), and consists of eight carbon cylinders or pencils mounted at the back of a thin pine-wood board 7 inches long and  $4\frac{1}{4}$  inches wide. This board is mounted on a substantial wooden frame with small india-rubber pads interposed, for the purpose of intercepting vibrations to which the body of the instrument may be subjected. Two strips of thin copper, *c c*, each having an angular outline, are fixed on the lower side of the pine-board, and on each of these are fastened four carbon buttons by means of little brass bolts passing through the centre of each button and through the diaphragm, and having little nuts

The next form of carbon-rod transmitter is one which for many years was the standard type of transmitter used by the British Post Office. The microphone is shown in Fig. 430, representing the cover (partly raised to

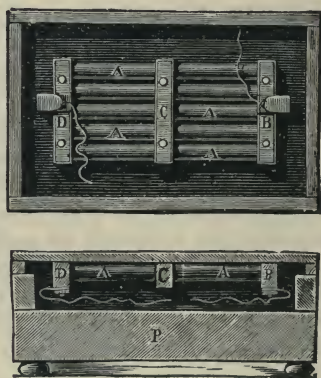

Fig. 429. — Ader's Transmitter.



on the lower or inner ends. The upper ends of these bolts protrude right through the board, so as to prevent it being used as a desk for writing purposes, for which its slope would otherwise make it very convenient, with, however, the danger of a probable dislocation of the carbon pencils underneath. There is also one large central carbon button fixed to the board in the same way. The carbon pencils are small cylinders with their ends turned down to fit loosely into circular holes in the buttons. They are arranged in the order shown, which may be described as electrically four in parallel and two in series. In all, there are sixteen phonetic contacts.

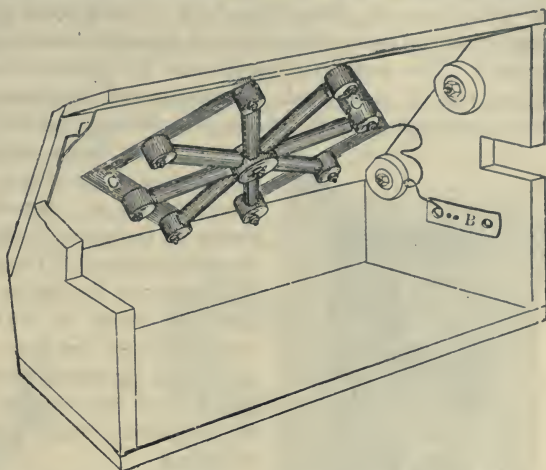

Fig. 430.—Gower-Bell Microphone formerly used by the Post Office.

The copper strips *c c* are connected by wires to two substantial pieces of brass *B*, of which one only is shown in Fig. 430. When the cover is placed in position on the base these blocks are screwed tightly to angle-shaped pieces of brass, making good electrical contact.

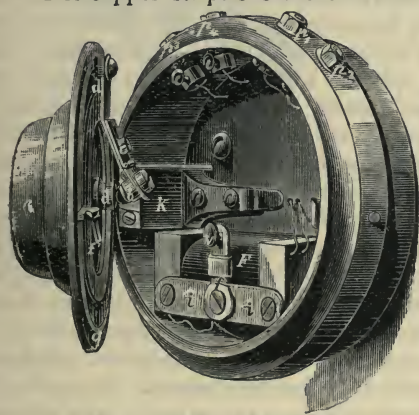

Fig. 431.—Berliner's Microphone.

Another very successful class of microphone transmitters is one in which the loose contact is made by a piece of solid carbon suspended at the end of a kind of pendulum which is set so that the carbon presses lightly, either directly or indirectly, against the centre of a vertical diaphragm. Numerous examples of this class might be given; we select two for our present purpose.

Fig. 431 represents Berliner's microphone or transmitter. The most important portion of the apparatus, viz. the variable carbon contact, is formed

by the two carbon pieces *a* and *b*; the former is fastened in the middle of the thin iron disc, which is attached to the door of the microphone; the second is placed at *c*, in the catch, which is hung from the movable arm *d*. The contact of the two carbon pieces is brought about by the weight of the carbon piece *b*. The support *d* serves also to maintain the iron disc in its position when the lid is opened. When in use, the poles of this sender  $p_1$  and  $p_2$  are connected with the poles of a battery (usually a Leclanché cell); the

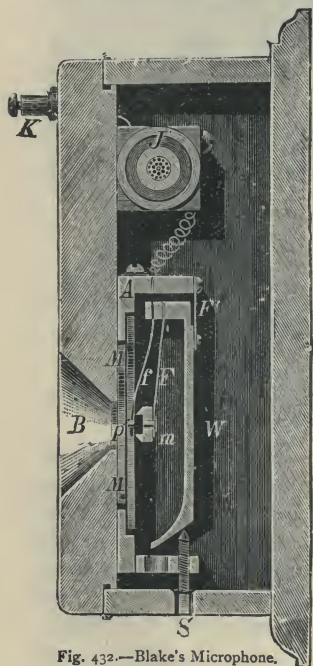

Fig. 432.—Blake's Microphone.

current then flows from clamp  $p_1$  through the metal piece *k*, to *d* and *c*, and so to the carbon pieces *b* and *a*; thence it returns through the spring *f*, the screw *v*, through the primary coil of the induction coil *F*, thence to the clamp  $p_2$ , and so back again to the battery. The clamps  $p_3$  and  $p_4$  hold the wires of the secondary coils, and are connected with the line. If the iron disc is made to vibrate by sound-waves, the two carbon pieces *a* and *b* will also vibrate, causing those alterations of resistance which make the battery current pulsating.

Blake's microphone, which belongs to this class, has been widely used and has done excellent work in this country. It differs from most of the others of the same class, in the fact that none of the contact-pieces are fastened to the membrane, thus preventing disturbances due to contraction or expansion of the membrane. The iron sheet *M M* is placed opposite *B* (Fig. 432), between pads of indiarubber tubing. One of the contact-pieces, consisting of a small platinum cylinder *p*, is fastened to the spring *f*, which presses it against the second contact-piece; a carbon disc (shown in the figure as a black rectangle) is set in the metal piece *m*, and carried by the spring *F*, which presses both carbon and platinum cylinder against the iron disc. The contact is regulated in the following manner:—The spring *F* is fastened to the plate *w*, which is again held by the heavy spring *F*, which is screwed to the fixed clamp *A*. The screw *s* presses against the inclined plane of *w*, and, by being turned in one or the other direction, effects the regulation. Blake's transmitter was, as a rule, used with a Leclanché element. The current passed as follows: Through the terminal *k* into the primary wire of the induction coil *J*, through the spring *f*, which was insulated from *w*, into the platinum cylinder *p*, through the carbon at *m* into *F*, through *w* to *s*, and then back to the battery.

The third class of microphones to which we shall refer is distinguished from the others by using as the loose contact a disc of hard

carbon, similar to those employed by Hughes in some of the experiments described on page 449. This disc is held between two flat metal electrodes of about the same diameter as the disc, and the apparatus is so arranged that the pressure of the electrodes on the disc is varied by the sonorous vibrations.

The early microphones of Edison belong to this class, one of the earliest forms being represented in Fig. 433. The case of the transmitter consists of metal, and has an ordinary speaking-funnel, opposite to which is placed the membrane *D*. Behind the membrane is fastened a metal plate, upon which the carbon disc *C* rests. This disc is held in position by an ebonite ring. The surface of the carbon disc nearest to the membrane bears a platinum

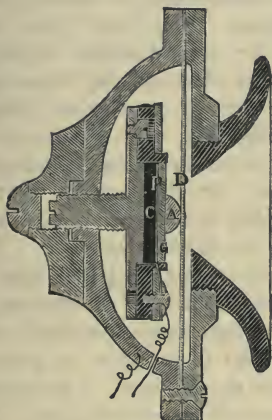

Fig. 433.

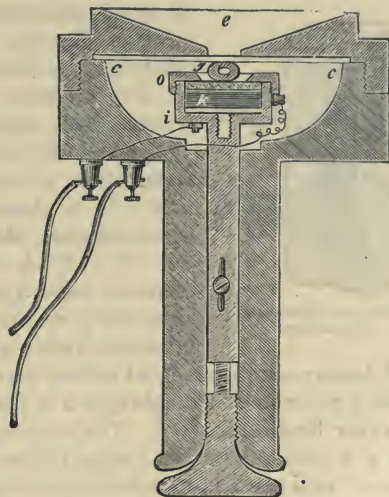

Fig. 434.

Edison's Carbon Microphones.

plate *P*, upon which the glass disc *G* is glued. This is connected with the membrane by the aluminium knob *A*, so that the vibrations of the membrane can be transmitted to the carbon *C*, and expose it to a pressure corresponding to the vibrations. A battery current sent through the carbon will therefore be converted into a pulsating current owing to the changes of pressure. When the plate *D* presses against the carbon, in consequence of the first or forward phase of its vibrations, the resistance of the carbon becomes less, and therefore the battery current flowing through it becomes stronger. The strength of the current diminishes when the pressure upon the carbon diminishes, by the return or second phase of the vibration of the plate, but a current of a certain fixed strength passes through the carbon when no additional pressure at all is exerted upon it, that is to say, when the plate or membrane is at rest. The current is conveyed through the carbon



by having one of the battery wires connected with the metal case of the telephone, and the other with the platinum plate *p*.

Another design of Edison's is shown in Fig. 434. The centre carbon disc *k* is placed between two platinum plates in a kind of box *o i*. The india-rubber tube *g* is placed between the membrane *c c* and an ivory disc, which rests upon the upper platinum plate. Each of the platinum plates has a clamp for the wires. The vibrations of the membrane are transmitted by means of the tube and ivory plate to the upper platinum plate, and thence to the carbon. The screw at the end of the case serves to regulate the microphone.

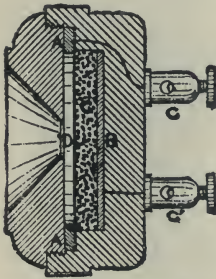

Fig. 435.—Hunning's Transmitter.

The fourth and last general class of microphones which we select contains all those instruments in which the carbon is in the form of dust-free granules, filling a suitable box or cavity with suitable electrodes liable to be disturbed by the sonorous vibrations. They are now very widely used, especially for long-distance working. The first instrument of this class was the Hunning's transmitter, invented in 1878, by an English clergyman. It is shown in Fig. 435, and consists of a small chamber, about  $2\frac{1}{4}$  inches in diameter, hollowed out of a block of wood. In the bottom of this chamber there is fixed a plate *B* of carbon or platinum electrically connected to the binding screw *c*. The chamber, which is now not more than  $\frac{7}{8}$  inch deep, is filled loosely with granulated carbon particles, free from dust, on the top of which a platinum foil diaphragm *D* is placed and connected electrically with the other binding screw *c*. The diaphragm is kept in its place by a metal ring *A A* which is firmly clamped down by the mouthpiece; a protecting piece of wide gauze is stretched across the bottom of the mouthpiece. The ends of the battery circuit are connected to *c* and *c'*, and the current in passing from one electrode to the other passes through the granules of carbon. The numerous contact points between these granules are disturbed when sonorous vibrations fall on the front diaphragm, and these disturbances alter the resistance of the circuit.

Some of the descendants of the Hunning's transmitter will be described in the later section. There are amongst them some of the most widely-used transmitters of the present day.

The successful working of a telephone system of wide extent, to which hundreds or even thousands of correspondents may be connected, certainly depends in great measure upon the perfection of the wonderful instruments, the transmitters and receivers, that we have been describing, since without them no amount of ingenuity exercised upon other details would be of any avail. But there is no doubt that, given good working transmitters and receivers, no large system can be successfully brought into operation and

maintained without the most careful attention to the design and working conditions of almost innumerable details in the lines, switchboards, and other necessary accessories. And even scientific perfection in these does not necessarily mean commercial success, for to attain the latter further conditions of economy of capital expenditure and up-keep, quickness in connecting subscribers, and numerous other points have to be kept in view.

Most of these things, however, with perhaps the exception of anti-induction devices and long-distance working, are matters chiefly of technical interest, and we therefore propose to leave their consideration to the second part of this book, for it is not possible to discuss further the scientific principles involved without some reference to such technical details.

## CHAPTER XIII.

*THE DYNAMICAL OR MAGNETIC PRODUCTION OF THE ELECTRIC CURRENT.*

ALTHOUGH Telephony is a subject the importance of which cannot be over-rated, and whose development is effecting a profound social revolution in many parts of the civilised world, another application of the principles of magneto-electric induction discovered by Faraday, in 1831, has, for at least the last forty years, attracted the attention of "the man in the street" more fully, perhaps by reason of the brilliancy of the effects which are produced by its aid. The economical production of electric currents of a magnitude undreamt of by the philosophers of the middle of the nineteenth century has made possible achievements which cannot but arrest the attention of every thoughtful man. They have placed in the hands of the engineer a new and powerful weapon in his ever extending adaptations of natural forces to the service of man, whilst they have given to the philosopher new powers of investigation and experiment, which are even now profoundly modifying our conceptions of many natural laws. It is the history of this development and some of the simpler principles underlying the design, construction, and working of the machines evolved that will be dealt with in the pages immediately following.

## I.—EARLY HISTORY OF CONTINUOUS CURRENT DYNAMO MACHINES.

The modern name for machines which convert mechanical or *dynamical* energy into *electrical* energy by taking advantage of the laws of magneto-electric induction, discovered by Faraday, is *Dynamo Electric Machines*, or more shortly **Dynamos**, and it may sometimes be convenient for us to apply the modern term to machines constructed before it had come into use.

The first dynamo, excluding some experimental pieces of apparatus constructed by Faraday himself (*see* page 482), was designed and made by Pixii as early as September, 1832, and was very soon improved by Ritchie, Saxton, and Clarke. It was probably preceded by a machine that never came into practical use, the description of which was given in a letter, signed "P. M." and directed to Faraday, published in the *Philosophical Magazine* of 2nd August, 1832. We learn from this description that the essential parts of this machine were six horse-shoe magnets attached to a disc, which rotated in front of six coils of wire wound on bobbins. The principle of



Pixii's machine will be understood from Fig. 436, in which  $sN$  is a powerful steel magnet made to rotate under the fixed soft iron cores  $a b$ . The rotation of  $sN$  causes currents to be induced that change twice in each complete revolution, viz., when  $s$  is opposite  $b$ , and  $N$  opposite  $a$ , and when  $s$  is opposite  $a$ , and  $N$  opposite  $b$ .

We may trace the effect produced by means of the laws of magneto-electric induction developed in the preceding pages. The mass of soft iron  $a b$  becomes magnetised by induction as  $sN$  approaches it, so that its north pole is nearest  $s$ , and south pole nearest  $N$ . The effect is therefore the same as would arise on the sudden introduction of a magnet into the coils surrounding  $a b$ . The sudden appearance of this magnet in the coils would, as we have seen, induce a current in the wire forming the coils

in the direction indicated by the arrows alongside the wires, this direction being such as to tend to magnetise the cores  $a b$  oppositely to the magnetisation produced by  $sN$ . The current is clockwise on the  $b$  limb and counter-clockwise on the  $a$  limb, but in the wire both currents flow from  $p$  towards  $p'$ . As the magnet continues to move,  $s$  leaves  $b$  and approaches  $a$ , while  $N$  leaves  $a$  and approaches  $b$ . If we now follow the directions of the currents, we find that they flow in exactly opposite directions to those in which they flowed during the previous motion, for now the magnetism of the cores is being first diminished and then reversed and increased in the opposite sense. It follows that the directions of the induced currents must change twice in the coil for every revolution of the magnet, namely, whenever the magnet  $sN$  passes the face of the cores  $a b$ .

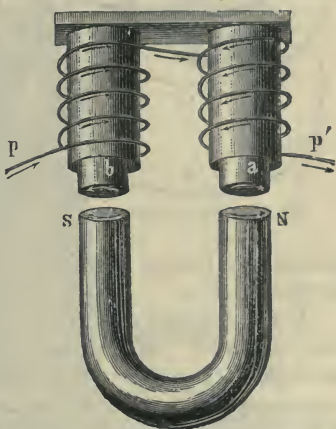

Fig. 436.—The Principle of Pixii's Machine.

The result is in accordance with Lenz' law : that is to say, the induced currents in the coil are such as will resist the motion. As  $s$  approaches  $a$ , then, the pole due to the current in the coil at  $a$  must repel  $s$ , and must therefore be a similar pole to  $s$ ; but as  $s$  leaves  $a$ , the pole of the coil at  $a$  must attract  $s$  to resist the motion, and must therefore be a dissimilar pole. This gives in  $a$  currents clockwise as  $s$  approaches, counter-clockwise as  $s$  recedes and  $N$  approaches.

**Pixii's Commutator.**—As the continued alterations in the direction of the currents might be inconvenient for many purposes, Pixii added a commutator to this machine, which caused the currents in the outer circuit to flow in one and the same direction. Fig. 437 represents the plan of the commutator. The axis of rotation of the horse-shoe magnet carries a cylinder made of insulating material fitting into a hollow cylinder of metal,

irregularly divided by an insulating layer into two parts  $M_1$  and  $M_2$ . Two metal springs  $F_1$  and  $F_2$  conduct the induced currents of the coils  $c$  into the commutator. Two other springs  $f_1$  and  $f_2$  conduct the currents from the commutator into the outer circuit  $s$ . During rotation the four springs slide along the surface of the cylinder. Observe that  $F_1$  and  $F_2$  always slide over the same portion of the cylinder, whilst  $f_1$  and  $f_2$  have to pass over the insulating strips, and thus change from one segment to the other at every half revolution. If the springs are properly adjusted they will pass the insulating layer—that is, will change metals—exactly at the instant when the direction of the current changes in the coil. We have seen that the direction of the currents changes twice for every complete revolution of the horse-shoe magnet. The springs  $f_1$   $f_2$  should slide from one portion of the metal cylinder to the other at the instant when the change of directions in the currents takes place, and the result of

this double change at the same instant is a uniform direction of the currents in the circuit  $s$ .

Fig. 438 shows how the different parts of the machine constructed by Pixii were arranged. The great drawback to the usefulness of this machine was that the heavy iron matter of the magnet had to be made to rotate, which must have caused considerable difficulty with machines of great dimensions.

**Ritchie's, Clarke's, and Siemens' Improvements.**—Almost at the same time, Ritchie, Saxton, and Clarke constructed similar machines. Clarke's is the best known, and is still popular in the small and portable "medical" machines so commonly sold. Its construction is as shown in Fig. 439. In front of a powerful horse-shoe magnet  $A B$  there are two bobbins  $t$  and  $t'$ , of insulated wire. These two bobbins have soft iron cores, connected by a soft iron cross piece  $o o$  so as to form a horse-shoe magnet, which rotates round a horizontal axis  $f$ , being driven by the pulley behind the magnet  $A B$ . The two

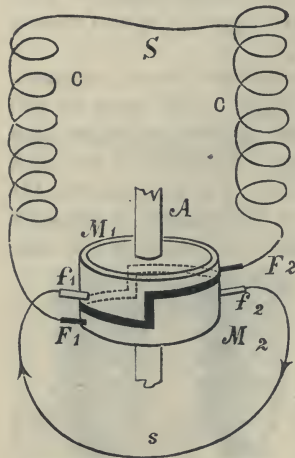

Fig. 437.—Pixii's Commutator.

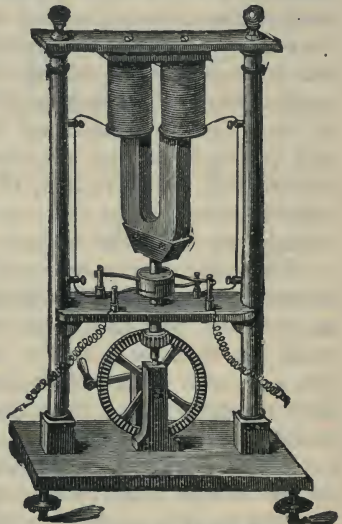

Fig. 438.—Pixii's Machine.

coils of wire are continuous, so that a single current may flow round both : but they are so joined that the current which flows in a clockwise direction round one, flows in a counter-clockwise direction round the other. While two ends of the wire on  $t$  and  $t'$  are directly joined, the two other ends are connected through a set of springs rubbing on suitable contact pieces on the axis  $f$ , with two fixed terminals, and the circuit is not complete till these are joined. We shall suppose this to be done. As the coils rotate, each soft iron core is successively magnetised in opposite directions ; thus coil  $t$ , when opposite a north pole, has its south pole near the magnet and its north pole at the back, and this arrangement of the magnetism is reversed when  $t$  is opposite the south pole ; thus, in every revolution a magnet is, as it were, introduced into  $t$ , withdrawn, replaced, with its poles in the opposite direction, and again withdrawn. The withdrawal of a magnet having its north pole at one end of  $t$ , and the introduction of a magnet having its south pole at the same end, both tend to induce an E. M. F. in one direction ; but the withdrawal of this second magnet, and the re-introduction of the original magnet,

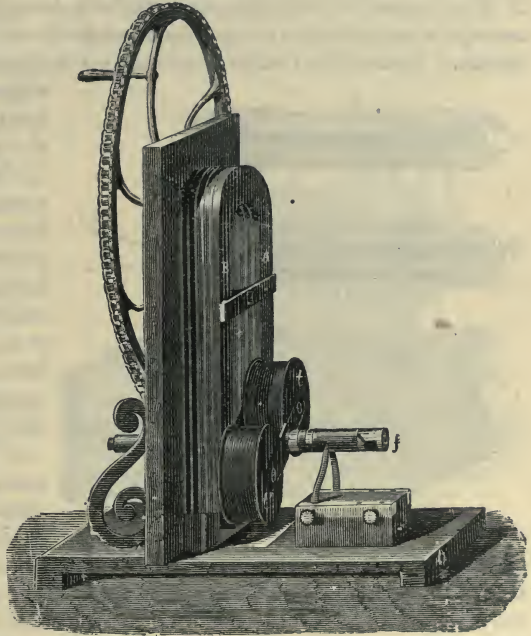

Fig. 439.—Clarke's Machine.

induce an E. M. F. in the opposite direction. Thus from the instant the coil  $t$  begins to leave the south pole, to that instant at which it arrives opposite the north pole, an E. M. F. in one and the same direction is being induced ; but as soon as  $t$  begins to leave the north pole and return to the south pole, the direction of the E. M. F. is reversed, and continues reversed until it is opposite the south pole again. Thus two equal and opposite E. M. F.'s are induced in  $t$  during each revolution. The same statements hold good of  $t'$ , but when the E. M. F. induced in  $t$  is clockwise, that in  $t'$  will be counter-clockwise. The coils being joined as described, the two E. M. F.'s are in series with one another. Without special provision the P. D.'s between the terminals would be reversed at every half-revolution ; but



the commutator on the axis  $f$ , already described, arranges that although the E. M. F.'s must necessarily be reversed in the coils, the currents shall flow always in one direction between the terminals. The currents between the terminals must, however, rise to a maximum and decrease to a minimum once during each half-revolution. The maximum currents occur at those points where the rate of change of magnetism in the armature (as the soft iron continuous core and coils are termed) is greatest. At these points the armature resists the motion most strongly.

The motion of the coils alone, without a core, would give rise to similar currents, as explained in the earlier pages of this work; but these currents would be much weaker than when iron cores are employed, because the changes of magnetic flux would be smaller, and therefore the rate of change at a given speed less rapid.

Stohrer in 1843 constructed a machine with six coils and three permanent magnets, whilst Nollet (1849) and Shephard (1856) still further increased the number of coils and magnets. Woolrich in Birmingham in 1844 built a machine, which was commercially used for electro-plating.

These improvements, however, were not of much practical importance, and it was not until 1857, a quarter of a century

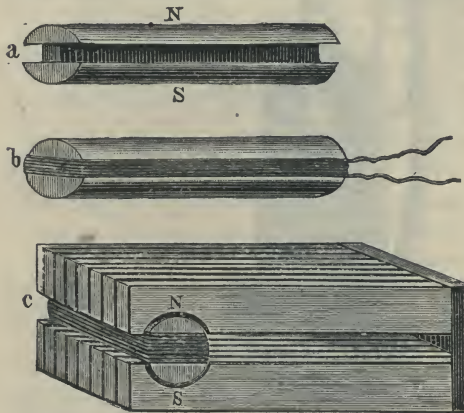

Fig. 440.—Siemens' Cylindrical Armature.

after Faraday's discovery, that the next step in advance was taken by Dr. Werner Siemens, who concentrated the magnetic field of his permanent magnet, and placed the rotating armature iron and coil, much more compactly arranged, in the strongest part of the field.

In its simplest form Siemens' armature consists of an iron cylinder which is cut (as shown in Fig. 440; *a*) so that its cross section is of the form of the letter **H**, but externally cylindrical. Covered copper wire is wound longitudinally round the cylinder thus prepared (Fig. 440; *b*). The horse-shoe magnets are placed parallel to each other, and cut out at their poles  $n$   $s$ , so that the cylindrical armature may move in the hollow space (Fig. 440; *c*). By this arrangement the coils are exposed to the most powerful magnetic effect, and, to use the language of Faraday, they cut the greatest number of lines of force in the most powerful part of the magnetic field. Fig. 441 represents a small Siemens' machine, by means of which more powerful currents were generated than by the earlier machines already described. *A* are the steel magnets placed vertically.

The cylindrical armature is seen at *E*. It is made to rotate rapidly by means of the multiplying wheel *B*; *x y* are the wires through which the induced currents are conducted into the outer circuit.

In a form closely resembling this the machine is still used for the "magnetó-calls" by which the subscribers "ring up" the exchange in many telephone systems, and in "magnetos" for automobile work.

The next important step was taken by Wilde in 1864, though, strange to say, Sinsteden as early as 1851 had pointed out the principle involved, and had even described in *Poggendorff's Annalen* one method of applying it. Sinsteden's suggestion was in effect that the current generated by a dynamo with permanent magnets might be used to energise much more powerful electro-magnets, by the action of which much larger currents could be obtained.

Wilde carried out this suggestion by using a small steel permanent magnet dynamo and larger electro-magnets, in a second dynamo as represented in Fig. 442. This machine consists of two Siemens' machines placed one over the other, the auxiliary machine *I* and the principal machine *II*. The permanent magnets *MM* of machine *I* generate currents in the cylindrical armature *n*, which are conducted through

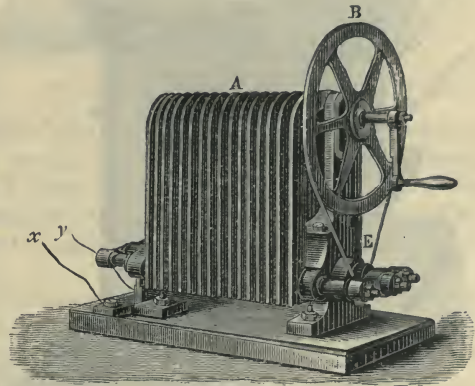

Fig. 441.—An Early Siemens' Machine.

*a b* to the coils of the electro-magnets *EE* of machine *II*. Between the pole-pieces *KK* of the electro-magnets *EE* another cylindrical armature *m* rotates, and from this armature currents for external work are drawn.

The large currents obtained with this machine were soon devoted to practical purposes. Wilde's machine, however, had one great drawback, which became the more objectionable the longer the machine was run, *viz.*, the mass of iron became rapidly so hot as to cause a decrease in the strength of the current. This made the generation of currents of a uniform strength impossible. Indeed, unless the armatures and coils were artificially cooled, the machine could only be worked for a short period without being permanently injured by the heat generated.

But the greatest forward step and the one which forms the starting point of the modern dynamo machine was the discovery that permanent steel magnets could be dispensed with, and that the residual magnetism usually found in the soft iron of an electro-magnet is sufficient to start the action of the machine. The small currents induced by this residual magnetism being



used to further energise the electro-magnet, the magnetism of the latter is more or less rapidly "built up" until the full power of the machine under the particular working conditions is developed.

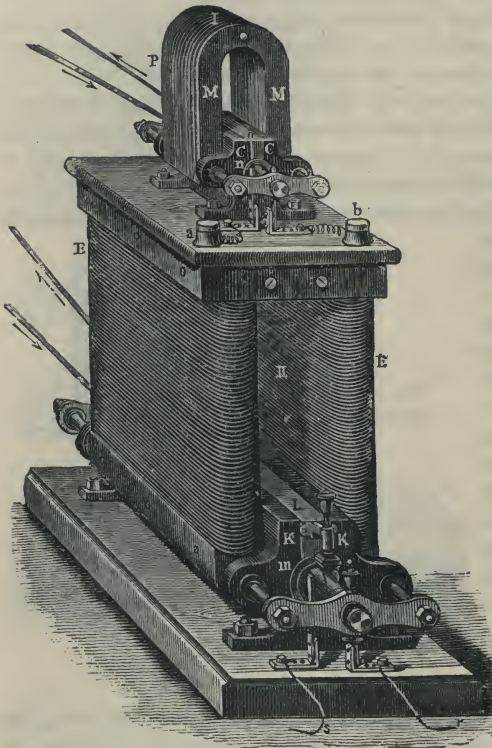

Fig. 442.—Wilde's Machine.

This principle was first enunciated by S. A. Varley in a patent filed in the British Patent Office on the 24th December, 1866, but not published till July, 1867. It was in February, 1867, that Dr. C. W. Siemens' classical paper on the conversion of dynamical into electrical energy without the aid of permanent magnetism was read before the Royal Society in London, but the machine referred to had been previously described by Werner Siemens, at a meeting of the Berlin Academy, on the 17th January, 1867. Strangely enough, the discovery of the same principle was enunciated at the same meeting of the Royal Society by Sir Charles Wheatstone, while, as we have already seen, there is yet a third claimant in Mr. Varley, who had previously applied for a patent

in which the idea was embodied. No one man can therefore be named as the first discoverer of the principle on which modern dynamo machines are constructed. As regards the Siemens' discovery, the originator of

\* Electrical science owes so much to the brothers Siemens, that the following details may not be without interest to the readers of a popular treatise:—Werner and Charles William Siemens were born at Leuthe, in Hanover. They were educated at the Gymnasium at Lübeck, afterwards at the Polytechnic School at Magdeburg, and finally at the University of Göttingen. Here they studied under Wöhler and Himly. In 1842 Charles became a pupil in the engine works of Count Stolberg, and here he laid the foundation of the engineering knowledge which he afterwards turned to such good practical account. The fact that these brothers belonged to a family of inventors makes it rather difficult to say what was the precise personal share each had in the many inventions for which the world is indebted to the four gifted brothers, Werner, William, Frederick, and Carl. It may, however, be said that in electrical discovery the two brothers William and Werner were principally associated. It was to introduce to the English



the idea seems to have been Dr. Werner Siemens, who, on being shown an electrical motor constructed without permanent magnets, immediately saw that a generator without permanent magnets was equally possible; but, as we have said, it was the second brother, Charles, who read the paper on the subject.

Fig. 443 shows the dynamo machine of Siemens in its simplest form. The yoke *P* of the electro-magnet *EE* has bolted to it the flat cores which at their other ends carry the soft iron polar extensions *N*, between which a Siemens shuttle-wound armature of the pattern already described is rotated. At the end of the axis of the armature is a two-part commutator (see page 484) upon which the sliding contacts *a b* press, and the currents generated in the armature are led into the coils of the electro-magnet as shown. The machine is self-exciting, though the currents generated are pulsating and not steady ones.

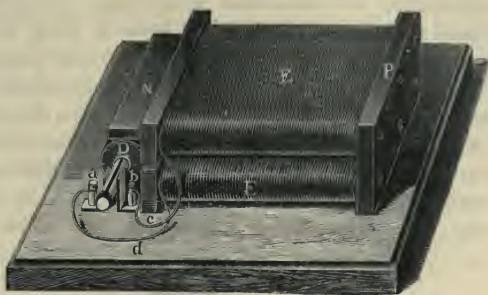

Fig. 443.—Siemens' Self-exciting Dynamo Machine.

**Ladd's Machine.**—Early in the same year (1867) the principle of using an electro-magnet only was applied by Ladd in a somewhat different way. He used two distinct coils on two armatures, one of which generated sufficient current to excite the electro-magnet, and the other generated the current for use

public a joint invention of his own and his brother Werner in electro-gilding that William Siemens first came to England in 1843. The details of the construction of the Siemens machine, and the various improvements by which it has been brought to its present form, or rather forms (for there are, of course, several varieties), are due alike to the younger and the elder brother. And the same may be said of the various inventions connected with telegraphy and the electric light which emanated from the great firm of Siemens Brothers. Some of these were entirely worked out by one, some by the other brother, but no attempt was made to separate them or to discriminate between them. To record fitly what they and their firm have done for the advancement, not only of electric lighting, but of the various practical uses of electricity, would involve the enumeration of an infinity of technical details, each comparatively unimportant, but each fitting into its own place, and serving to produce a complete whole. The electrical transmission of power is a field they made peculiarly their own. With the exception (and an exception of undoubted importance) of storage batteries, the early advances in this direction were principally due to them. The Berlin electric railway and that at Portrush are alike the work of one or other branch of the firm, while those who ever had the pleasure of being shown round his country house, near Tunbridge Wells, by Sir William, can best realise how much he individually did to reduce to human servitude the forces of that mysterious power of which he was so great a master. Not only did electricity perform a large part of the actual work of the farm, sawing wood and pumping water, but it was made to supply in part the place of the sun itself, and assist the growth of plants and fruits. In April of 1883, Dr. William Siemens received the honour of knighthood, in recognition of his scientific discoveries, and on November 18th, of the same year, he died. "Looking back along the line of England's scientific worthies, there are few who have served the people better than this, her adopted son; few, if any, whose life's record will show so long a list of useful labours."

outside the machine. Fig. 444 represents a machine constructed by him, and exhibited at the Paris Exhibition in May, 1867. It consists of two electro-magnets, placed magnetically in series with one another, and two Siemens' cylindrical shuttle-wound armatures. The two electro-magnets B and D consist of iron plates, which have at their ends A A, free from wire, semi-cylindrical hollowed-out pole-pieces, the pole-pieces of the magnet B being denoted by the letters c c and c' c' in the figure. The two cylindrical armatures have commutators at m and n, the springs F and F' each leading to two clamping screws. The cylinders are driven by ordinary belts. The springs F, which slide on the smaller cylindrical armature, are so connected with the wires of the electro-magnets B D, that the wires of the magnets and armatures form a closed circuit. The wires in the electro-magnet

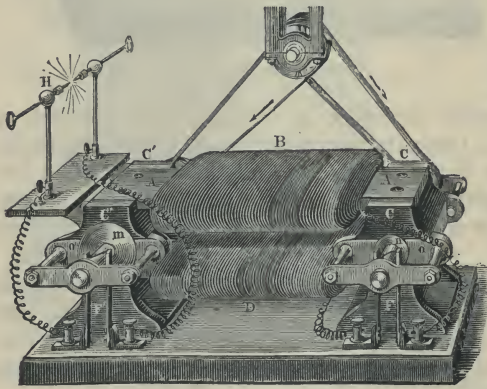

Fig. 444—Ladd's Machine.

are so wound that at each cylindrical armature two opposite poles stand opposite to each other. The right-hand half of Ladd's machine is simply a Siemens' dynamo machine, similar to the one just described. When the machine is started the residual magnetism induces weak E. M. F.'s in the two armatures. The currents from the smaller armature *n* are conducted into the coil of the electro-magnet, and increase the strength of the

magnet; then, owing to the mutual action between magnet and armature, the strength of the currents increases progressively until the steady state is reached. The currents generated in the right-hand armature are only used for the electro-magnets, whilst the currents generated in the left-hand armature may be utilised for any suitable purpose, as, for instance, for a hand-fed arc light at H.

The shuttle-wound armature of Siemens, with its solid polar extensions, is not adapted for the generation of heavy currents, for many reasons which will appear in the sequel. A great advance in the construction of armatures had already been made by Pacinotti in 1860, but his machine had passed into oblivion, and his method with some important modifications was re-invented by Gramme, in 1871, as the now well-known *ring* armature, whilst Von Hefner-Alteneck, of the firm of Siemens and Halske, of Berlin, attained similar advantages with the *drum* armature which he invented in 1872.

Before describing these armatures which form the types of most of the armatures of continuous current dynamos constructed at the present



time, we shall interrupt this historical summary for a short time to place before the reader some of the principles involved in the construction of modern machines.

## II.—ELEMENTARY PRINCIPLES OF DYNAMO CONSTRUCTION.

The fundamental principle upon which the action of all dynamos depends is the law of magneto-electric induction discovered by Faraday. As originally and usually enunciated, this law refers to the induction of currents under certain stated conditions. But electric currents can only flow in closed circuits in which there must be electric pressures or electro-motive forces as they are usually called. Now these *E. M. F.*'s or electric pressures can exist in conductors even though the latter be not part of a closed circuit, and therefore without the currents being actually generated. The cause producing the *E. M. F.* is, as a rule, independent of any condition as to the completion or otherwise of the circuit; the *E. M. F.* is a measure only of the *tendency* to produce a current if the whole of the conditions, including a complete circuit, are present.

For our present purpose we propose to use the law of magneto-electric induction in the form stated on page 423, *viz.* :—“Whenever lines of force move across a conductor an *E. M. F.* is set up in the conductor proportional to the rate at which the magnetic lines are moving across it.” The direction of this *E. M. F.* will be given by Lenz' law (page 418), it being supposed that currents are allowed to flow in the conductor in the direction of the *E. M. F.*, these currents being such that their flow will tend, by the magnetic effect produced, to stop the motion of the magnetic lines across the conductor (or the conductor across the lines, which is physically the same thing). If no currents actually flow no hindrance to the motion is experienced, but the *E. M. F.*'s are set up all the same.

To enable the reader to predict more quickly the direction of this *E. M. F.* generated in any particular case, the corkscrew rules already given (*see* pages 276 and 280) require some little extension. Consider the three cases depicted in Figs. 445, 446, and 447. In Fig. 445 the smallest circle *IN* is intended to represent the cross section of a wire carrying a current vertically downwards (“*IN*”) through the plane of the paper. The other concentric circles represent some of the lines of force, in the plane of the paper, that would be set up by such a current, the arrowheads showing the direction of the lines of force in accordance with the corkscrew rule. Fig. 446, consisting of equidistant parallel straight lines, represents a uniform field from *N* to *S*, the wire being shown in cross section in the centre, but carrying no current and therefore not disturbing the field. Consider what will be the result if these two fields are superposed, that is, if the wire in the centre of the field in Fig. 446 have a vertical

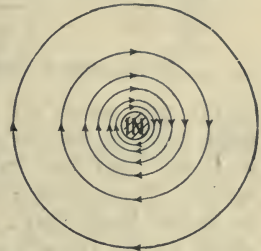

Fig. 445.—Lines of Force Round a Straight Current.



current sent downwards through it giving rise to the field of Fig. 445. The result would be something like what is depicted in Fig. 447. The lines on the lower side of the frame are in the same direction for both fields and therefore produce a stronger field, whilst those on the upper side oppose one another and produce a weaker field. On the right and left the lines cross

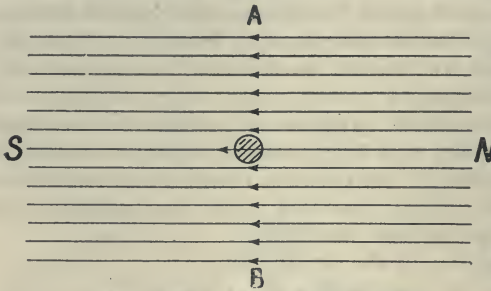

Fig. 446.—Lines of Force of a Uniform Field.

one another and therefore produce fields more or less twisted. The result is as shown in the figure, and remembering that the tendency of the lines of force is always to contract, we have a graphic representation of the existences of stresses that would urge the wire across the paper from *n* towards *A*. The actual motion

of the wire which will give rise to the inductions producing these effects must, by Lenz' law, be in the opposite direction, that is from *A* towards *n*, in order that the induced currents may set up forces *opposing the motion*. Remembering that the current in Figs. 445 and 447 is downwards, we deduce finally that a motion from *A* towards *B* of the wire across the field shown in Fig. 446 will set up an E. M. F. directed downwards in the wire. In other words, the direction of the induced E. M. F. will be such as to tend to generate a current which will *strengthen the field in the direction towards which the wire is moving*. The case in which the field moves and the wire is stationary can be solved

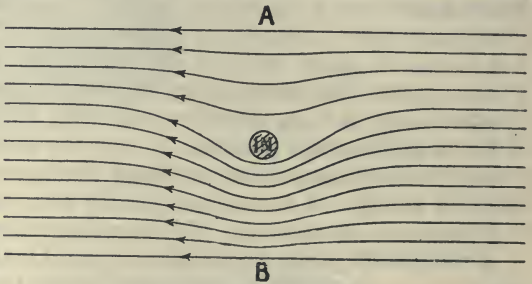

Fig. 447.—Lines of Force of a Straight Current placed in a Uniform Field.

by remembering that all motion is relative, and we have only to imagine the wire stationary and the field moving so that the lines sweep across the wire, as they actually do, and then the above rule will again apply.

A simple and ingenious mnemonic devised by Dr. S. P. Thompson may assist the reader in remembering the important relations between the three directions, *viz.* :—(a) the lines of the field, (b) the motion of the wire, and (c) the induced E. M. F. In Fig. 448 let the rectangles *s* and *n* denote respectively south and north seeking poles, so that the lines of force issue outwards from *n* and run inwards to *s*. The two rectangles are shaded with oblique

lines in opposite directions, those on the N rectangle sloping parallel to the oblique stroke of the N. Let  $ab$  and  $cd$  be two conductors that are being moved across the faces of the poles in the directions indicated by the dotted arrows. Then the heavy arrows show, according to the preceding rules, the directions of the induced E. M. F.'s. These directions can be ascertained by moving across the face of either pole in the specified direction a sheet of paper P in which a slot  $cc$  has been cut to represent the conductor. As the slot  $cc$  moves across either pole the oblique lines will appear to move either upwards or downwards in the direction of the induced E. M. F. This rule is, as we have said, purely a mnemonic rule, but it is easily remembered and applied.

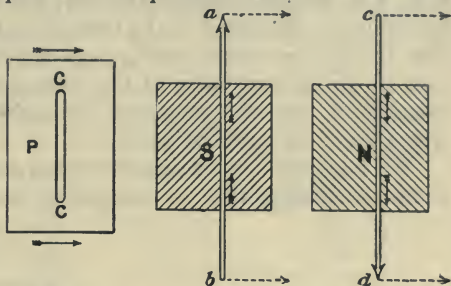

Fig. 448.—Induction in Wires moving across Magnetic Poles.

To produce these induced E. M. F.'s practically, it is obviously necessary to arrange for the relative motion of a conductor and magnetic lines of force so that the latter sweep across the former, or *vice versa*. Perhaps the simplest case possible is that shown in Fig. 449, in which a slider A B, which may be one of the axles of an express railway train, is being moved southwards along the rails C D and F H so as to cut the vertical lines, directed downwards, of the earth's magnetic field. It is readily seen that there is an E. M. F. directed towards the east or B end of the slider or axle which would cause a current in the direction shown in the circuit of the galvanometer G. Unfortunately, even with

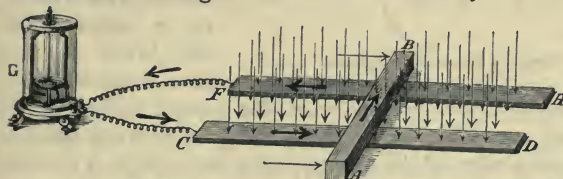

Fig. 449.—E. M. F. in Conductor cutting Lines of Force.

a train moving southwards at the rate of 60 miles per hour, this E. M. F. induced in any axle is only about 0.0039 volt. For practical purposes it is useless.

It is, however, possible to arrange for a moving conductor to cut lines of force continually in the same direction without making use of a magnetic field of practically infinite extent like that of the earth. In fact, in the "new electrical machine" described by Faraday himself in one of his early Researches,\* a method of doing this is adopted. Figs. 450 and 451, copied from Faraday's paper on the subject, illustrate the mode of action. A copper disc  $c$ , twelve inches in diameter and one-fifth of an inch thick, was mounted

\* "Experimental Researches," i. 25, art. 85.

on a brass axle so that it could be easily rotated, and its edge was introduced between the poles *N S* of an electro-magnet *E*. Two bars *n* and *s* were attached to the poles to concentrate the magnetic field in the narrow gap within which the edge of the disc was introduced. Collecting brushes *b*<sub>1</sub> and *b*<sub>2</sub> (Fig. 450) rubbed against the edge of the disc and the axle, both of which were well amalgamated for the purpose of making the contact good; these brushes were connected to the terminals of a galvanometer. On rotating the disc the galvanometer needle was deflected, showing the existence of a continuous current always in the same direction as long as the direction of rotation of the disc remained the same, but rising or falling with any alteration of the speed of rotation.

We have here then a simple dynamo machine giving a continuous current, and so constructed that *no commutator* is required, for there are no reversals

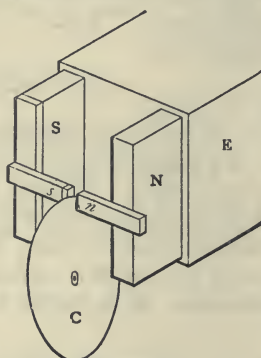
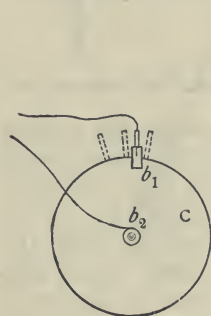

Figs. 450 and 451.—Faraday's Simple Disc Dynamo.

of current in the rotating armature *C*. It should be noticed that each radial sector of the wheel *C*, as it comes between the poles, may be regarded as a conductor cutting lines of forces. There is therefore an *E. M. F.* set up in each sector as it passes under the brush *b*<sub>1</sub>, and this *E. M. F.* being

always in the same direction, and the sector at the instant being part of the galvanometer circuit, currents flow in the latter. By putting another pair of poles for the opposite edge of the disc to rotate between, it is obvious that we can do away with the brush rubbing on the axis and draw off the current by two brushes at opposite ends of a diameter. In this case the direction of the induction must be such as to cause the currents in the active sectors to flow either both upwards or both downwards; and the induced *E. M. F.* is, of course, oppositely directed as regards the *material* of the conductor in the two positions. Attempts have been made from time to time to apply this method of generating continuous currents, but they have not met with marked success.

Consider next the simple case of a rectangle of copper wire *a b c d* (Fig. 452) arranged to be spun in the magnetic field between the poles *N S* of a magnet, the wire being cut at *f* and the two ends joined respectively to the two parts *s s'* of a split metallic ring as shown more clearly in Fig. 454. The direction of the rotation is assumed to be clockwise. As the wire *a b* sweeps



downward across the face N of the magnet the induced E. M. F. in accordance with the above rules will be from  $b$  to  $a$ . Simultaneously the wire  $c d$  is sweeping upwards over the face of the S pole, and the induced E. M. F. in it will be from  $d$  to  $c$ . No E. M. F.'s will be induced in the other parts  $a d$ ,  $b f$ , and  $f c$  of the wire, as these parts do not, during the rotation, cut across any of the lines of force. On the whole, then, we have during the first half revolution from the position shown an E. M. F. in the rectangle in the direction  $b a d c$ , the effect of which is to produce a potential difference (P. D.) between  $s'$  and  $s$ , the former being at the higher potential.

We can easily calculate the mean magnitude of this E. M. F. or P. D. if we know the total number  $N$  of the magnetic lines cut by the wire  $a b$  in moving from the top to the bottom position, and the speed of rotation of the rectangle, say  $n$  revolutions per second. We have then:

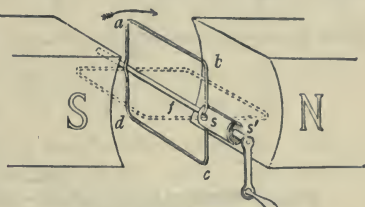

Fig. 452.—Ideal simple Dynamo.

Lines cut in half a revolution by  $a b = N$ .

Time occupied in cutting these  $= \frac{1}{2} \cdot \frac{1}{n} = \frac{1}{2n}$  second.

Mean rate of cutting  $= \frac{N}{\frac{1}{2n}} = 2n N$  lines per second.

Therefore, mean E. M. F. (from  $b$  to  $a$ )  $= \frac{2n N}{10^8}$  \* volts.

There is an equal mean E. M. F. in  $d c$  from  $d$  to  $c$ ; hence  
 Mean E. M. F. in rectangle (during the half revolution)  $\left. \vphantom{\begin{matrix} \text{Mean E. M. F. in rectangle} \\ \text{(during the half} \\ \text{revolution)} \end{matrix}} \right\} = \frac{4n N}{10^8}$  volts.

The above calculation gives the *mean* voltage, but if the field between N and S be quite uniform as depicted in Fig. 446, it is evident that when  $a b$  is in the topmost position it is only sliding along the lines and not cutting them, and the E. M. F. is then *nil*. As  $a b$  moves over it cuts the lines at a more and more rapid rate until, when half way down, the rate of cutting reaches its maximum, and the E. M. F. has its highest value. From this position it gradually diminishes to zero.

If we plot a curve in which the various angular positions of the loop

\* The divisor  $10^8$  is required because 100,000,000 lines must be cut each second to give an E. M. F. of one volt.

are set off horizontally (the position shown in Fig. 452 being the zero position), and the E. M. F.'s induced as the loop passes each position set off vertically, we would get a curve similar to the first half of Fig. 453

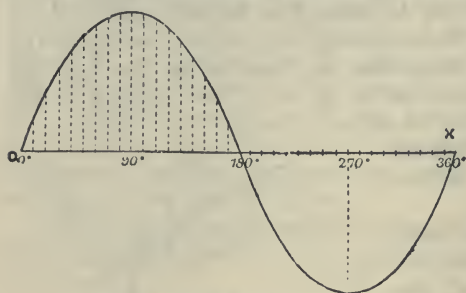

Fig. 453.—Change of E. M. F. in Loop rotating in Uniform Field.

from  $0^\circ$  to  $180^\circ$ . The mean height of this curve will represent  $\frac{4\pi N}{10^8}$  volts.

In the next half revolution, during which  $a b$  moves from the bottom to the top or starting position, all the above changes occur over again, but the direction of the E. M. F.'s is reversed, their magnitudes being the same as before. Plotting these on our diagram,

but in the opposite or *negative* direction, we shall obtain the second half, from  $180^\circ$  to  $360^\circ$ , of the curve in Fig. 453.

This curve may also be taken to represent the P. D. between  $s'$  and  $s$ , this P. D. being alternately in opposite directions. The loop and split-ring are shown on a larger scale in Fig. 454, in which the loop is cut at  $A'$  and  $a'$  and the ends carried to the two segments A and B of the split-tube. On this tube there press two sliding contacts  $b$  and  $a$  in such a position that they change connections on the split-ring as the rectangle passes the vertical or zero positions. The split-tube, which is known as a "two-part commutator," is shown in section in Fig. 455 as it would be mounted in practice. Solid insulating material H is rigidly attached to the axle x which carries the revolving rectangle, and the two halves  $s'$  and  $s$  of the split-tube are carried by H. The sliding contacts or "brushes"  $b$  and  $a$  are supported in suitable brush-holders.



Fig. 455.—Two-part Commutator or Collector.

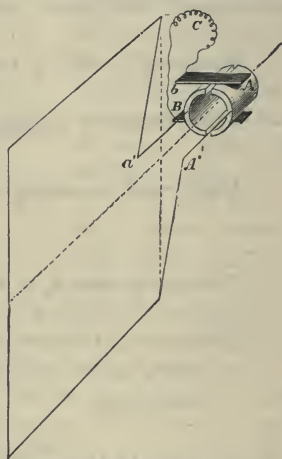

Fig. 454.—Connections of Loop for Continuous Currents.

It follows that, although the P. D.'s of A and B are alternately in opposite directions, the P. D.'s of  $a$  and  $b$  are always in the same direction, though fluctuating between zero and a maximum. It is as if the second half of Fig. 453 had been reversed, giving the pulsating curve shown in Fig. 456. This latter curve represents then the changes of the potential difference of  $a$  and  $b$  and the currents in the outer circuit c.

In the above the device of the split-ring is used to obtain unidirectional currents in the working circuit *c*, for from the very nature of the case the induction in the rotating wires must be subject to reversals. If, however, reversing or alternate currents are desired in the working circuit only some sliding contact is required to connect the fixed and moving parts of the whole circuit. One method

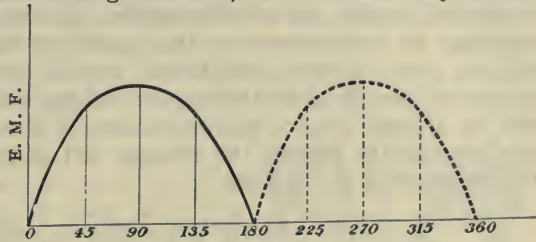

Fig 456.—Commuted Alternate Currents.

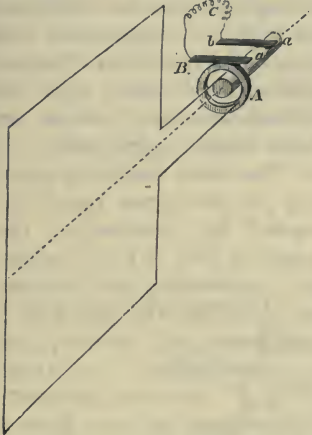

Fig. 457.—Connections of Loop for Alternate Currents.

of arranging such sliding contacts is shown diagrammatically in Fig. 457. The two ends of the wire of the rectangle are led, one to the axle *aa* and the other to a metal ring *A* mounted on the axle, but insulated from it. Sliding contacts *b* and *B* press on the axle and ring respectively, thus conducting, unchanged, into the fixed part of the circuit *c* the alternate currents generated in the revolving rectangle.

For the remainder of this section we propose to confine ourselves to those machines which give *continuous or uni-directional currents* in the working circuit.

Returning now to the magnitude  $\frac{4n N}{10^8}$

of the E. M. F. induced in the rectangle we observe that it will be increased by increasing the speed of rotation *n*, a result we should have expected from Faraday's fundamental law. The E. M. F. is also pro-

portional to *N*, the total number of lines, passing from *N* to *S* (Fig. 452), which are cut by the wires of the rectangle. Now, the kind of field shown in Fig. 452 is not conducive to a high value of *N*, for the non-magnetic gap between *N* and *s* is wide. The number of lines will be greatly increased

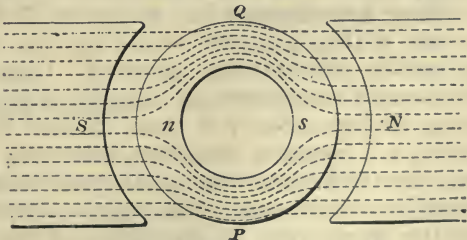

Fig. 458.—Armature Iron in Polar Gap.

by the introduction of soft iron into this gap, and in practice this is usually supplied in the shape of a hollow cylinder of soft iron as shown in Fig. 458.



The quantity of iron introduced is, as a rule, sufficient to carry the greater part of the lines across, so that none is found inside the cylinder and very few outside in a well-designed machine. If our copper wire rectangle be now wound on the *outside* of this cylinder the E. M. F. will be much greater than before, because, whether the magnet be a permanent one or an electro-magnet, but especially in the latter case, there will be a great increase in the number of lines  $N$  passing from pole to pole through the iron of the cylinder, and all these lines will be cut by the rectangle in its rotation.

### III.—CONTINUOUS CURRENT ARMATURES.

From such a simple arrangement as a single rectangle wound on the iron cylinder we could not expect great results, and it is an obvious development to wind on a number of such rectangles, if only the difficulties of connecting them electrically together and with the commutator can be satisfactorily overcome. This was accomplished by Von Hefner-

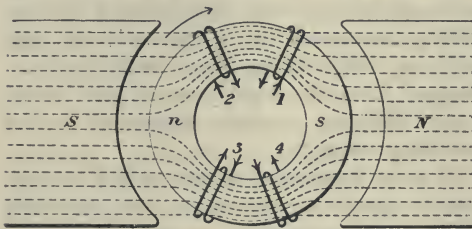

Fig. 459.—Conducting Coils on Ring.

Alteneck in 1872 with his "drum armature," which we have already mentioned.

The other method of arriving at the same result invented by Gramme in the previous year (1871) consists in over-winding the cylinder or "ring" in Fig. 458 with a continuous coil of wire, connections being made at suitable intervals to a commutator. An armature so wound is known as a "ring armature" or a "Gramme armature."

Gramme's method, however, was only an improvement on one devised by Pacinotti in 1860, which we shall describe in due course. We shall now give details of the principles underlying both methods of winding, taking them in historical order.

**Ring Armatures.**—Let us suppose first that four separate coils, 1, 2, 3, and 4 (Fig. 459), are wound on the iron ring or "core," as it is technically called, of the armature. These coils are all similar, but at the moment occupy different magnetic positions on the ring. The rotation being clockwise, No. 1 is about to enter the field under the north pole, whilst 2 is emerging from that under the south pole; again, 3 is entering the field under the south pole, whilst 4 is emerging from that under the north pole. The magneto-electric inductions take place only in the wires lying on the surface of the cylinder, which alone cut the lines of force, and whose projections only are seen in the diagram. These we shall in future refer to as the "active" wires, the remainder of the wire being so much dead resistance, contributing nothing to the E. M. F.,

but being necessary for connections. In coils 1 and 4 the inductions give rise in these outer wires to E. M. F.'s directed from the spectator, whilst in coils 2 and 3 the E. M. F.'s are directed towards the spectator. The consequence is that electric pressures are set up at the severed ends of the wires in the directions indicated by the various arrow heads.

Consider now what would happen if the adjacent ends of coils 1 and 2 were joined and the circuit, somehow, completed. The E. M. F.'s in the two coils being supposed equal, no flow would take place, but the junction would be at a higher potential than the loose ends of the coils, and if a wire were attached to this junction, and the necessary circuits completed, a current would flow along this wire outwards from the junction. We may understand more

clearly how such a flow would take place under the supposed conditions by considering an analogous case:—that of water. Imagine the two spirals 1 and 2 filled with water, as shown in Fig. 460. Suppose that at the end of each coil a piston is introduced to produce a pressure. If the pressures at *c* and *d* are equal, the water inside the coils will

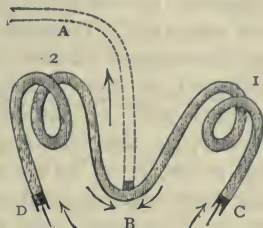

Fig. 462.—Current from two opposing Pressures.

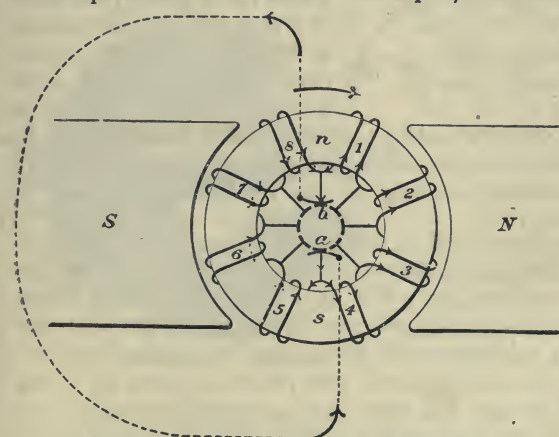

Fig. 461.—Conducting Coils connected to Commutator.

have no motion. When now at the junction *B* a third and open channel *B A* is placed, the water will flow through *B' A*, in the direction indicated by the arrow. Suppose a similar arrangement were made at the junction of the coils 3 and 4 on the other side (Fig. 459), but with the pistons moving in the opposite direction, the water would be drawn away from *A*, and the tendency to flow increased in the pipe joining the two junctions.

We can now readily pass to the case (Fig. 461) in which the coils are more numerous, and are united at their adjacent ends so as to form a continuous winding round the ring. Eight such coils are shown in the figure, and the eight junctions are shown diagrammatically as connected to the sections of an eight-part split-tube commutator on which two fixed sliding contacts or brushes rub at *a* and *b*.

An examination, by the rules already given, of the inductions in the "active" wires on the outer surface of the ring will show that in all the wires *descending* on the right-hand side of the ring the induced E. M. F.'s are directed *from* the spectator, whilst in those which are *ascending* on the left-hand side the E. M. F.'s induced are directed *towards* the spectator. The consequence is that on the connecting wires seen on the surface of the ring the electric pressures are in the directions indicated by the various arrow heads. A further consequence is that at two only of the junctions are the pressures oppositely directed, namely, at the one connected to the bar *b* of the commutator, where the pressures on either side are both directed *towards* the junction, and the other at the junction connected to the bar *a*, at which the pressures are both directed *from* the junction.

Three results follow from this distribution of pressures, (I.) that, although great E. M. F.'s may be and are induced in various parts of the ring winding, no current will flow in this winding, notwithstanding the fact that it forms a closed circuit, because the pressures on the two sides

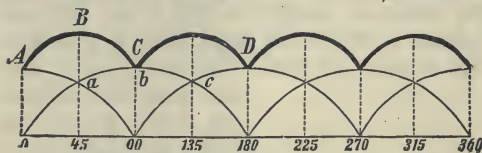

Fig. 462—E. M. F.'s of Two Pairs of Coils in Series.

of the ring balance one another, being equal in magnitude and oppositely directed; (II.) that the electric pressure at the bar *b* will be higher than at the bar *a*; or, in other words, these bars will be at different potentials; and, therefore, (III.) that if *b* and *a* be connected by a conductor *c*, as indicated by the dotted line, electric currents will flow continuously in this conductor so long as the rotation of the ring is maintained.

The steadiness of this current and its freedom from perceptible pulsation depend on the number of coils and commutator segments used, provided the speed of rotation be kept constant. We have seen that with a single rotating rectangle and a two-part commutator the E. M. F. rises and falls (Fig. 456) from zero to a maximum, and back again twice in each revolution. The same result would be obtained with two coils placed on a ring at opposite ends of a diameter and with their junctions connected to a two-part commutator. If we increase the number of coils to four placed 90° apart on the ring, each pair of coils may be regarded as giving a pulsating E. M. F., changing as shown in Fig. 456. Such E. M. F.'s, if plotted separately on the same diagram, would give the fine-line curves *a b c* of Fig. 462; for it must be remembered that the two pairs of coils reach their maxima at intervals 90° apart. But from the method of connection these E. M. F.'s are added at every instant throughout the rotation, and, therefore, the final result will be that given by the thick-line curve A B C D, which is obtained by the geometrical addition of the



two curves below it. The pulsations are clearly perceptible, but the resultant E. M. F. never sinks to zero, and the range of variation is considerably reduced.

To carry the argument one step further: suppose two such sets of four coils, each to be arranged symmetrically round the ring as in Fig. 461, each set of the four will give one of the fine-line curves depicted in Fig. 463; but the maxima of one curve will lie exactly over the minima of the other.

On adding these curves we obtain the thick-line curve shown in the figure, in which the pulsations are still further reduced in range or amplitude, no individual value differing very much from the mean.



Fig. 463.—E. M. F.'s of Four Pairs of Coils in Series.

A comparison of the three figures 456, 462, and 463, for 2, 4, and 8-part commutators, shows how rapidly the multiplication of the commutator segments tends to wipe out the amplitude of the pulsations, and it may fairly be deduced from these figures that when the commutator segments become much more numerous, say 32 or more, the pulsations, though theoretically present, cease to have any practical effect.

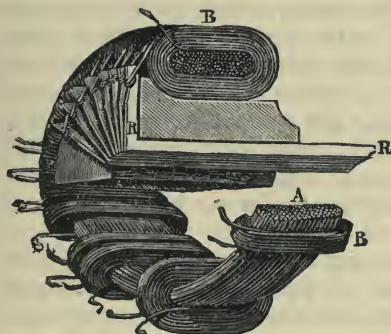

Fig. 464.—Section of a Gramme Ring.

The methods adopted by Gramme to carry out in practice the theoretical ideas of the preceding paragraphs are shown in Fig. 464, in which A B represents an incomplete ring armature coil, the upper portion of the figure showing a completed section. The coils consist of copper wire, well covered, the number of turns and the thickness of the wire depending upon the purposes for which the machine is to be used.

The connections of the coils are shown in the figure; the end of one coil and the commencement of the one next to it are soldered to copper strips R, which are bent at right angles and protrude on the other side of the ring. The number of copper strips is equal to the number of coils; these copper strips together form a hollow cylinder, and are separated by insulating substances from each other. In the middle of this hollow cylinder the steel shaft is fixed, being, of course, well insulated. The space between the copper strips and the coils is taken up by a wooden ring. To conduct away the currents induced in the Gramme ring two wire brushes are fastened in such a manner that they slide over the exposed end surface of the cylinder formed by the copper strips R R.

**Lamination of Cores.**—We have already (*see* page 428), when dealing with induction coils, drawn attention to the necessity for laminating the iron cores so as to kill, as it were, any currents which would be induced in solid iron cores under the conditions of working. Such currents are frequently referred to as “Foucault currents” or “eddy currents.” Almost precisely similar conditions hold with regard to the cores of continuous current armatures. We have an iron core surrounded by coils in which rapid reversals of current are taking place. If the iron core were solid these reversing currents would induce currents in the iron in directions parallel to themselves, these being the directions of the induced E. M. F.’s in the iron. We must, therefore, laminate the iron in such a way that no closed circuits of appreciable extent can be formed in these directions.

But apart from the currents in the coils the iron core is being spun in a magnetic field in such a manner that the magnetic flux through every part of it is being rapidly reversed. This by itself would tend to set up “eddy” currents in the iron if the latter were solid; for then innumerable closed circuits, of low resistance, would exist, the magnetic flux through which would be continually changing. In such circuits induced or “eddy” currents would flow.

The effect of “eddy” currents in both cases would be that the iron would rapidly become heated, and therefore that energy, which could have been more usefully employed in doing work in the outer circuit, will be spent in wastefully warming the iron from which it will be radiated or diffused and cease to be available. Thus, apart from any deleterious effect on the machine itself which may be caused by overheating, the production of heat in this way is wasteful and uneconomical. We have already mentioned how Wilde’s machine (*see* page 475) heated up so quickly that it could not be run for very long without stopping. The mischief was due to the solid iron core of the H armature.

The laminations required are at right angles to the currents in the coils and parallel to the direction of motion. Gramme secured the necessary lamination by building up his core of iron wire well annealed so as to secure high permeability. This core of iron wire can be clearly seen in Fig. 464. Iron wire, however, is not sufficiently rigid, especially for large machines, and therefore in modern machines thin iron discs are threaded on the axle and built up to form a core of the required shape and size. These discs have some form of light insulation inserted between them sufficient to stop “eddy” currents, the E. M. F.’s of which are usually small, passing from one disc to another. Details will be given in the descriptions of the machines.

**Drum Armatures.**—The other leading type of winding for continuous-current armatures to which we have referred is the drum armature designed by Von Hefner-Alteneck in 1872. It will have been noticed that in ring armatures the “active” part of the winding is that which lies at the outer surface of the ring, and that the rest of the wire merely supplies the

necessary electrical connections whilst adding considerably to the quantity of wire used and therefore to the resistance of the armature. It seems natural to seek to do away with some of this wire, and especially that which lies on the inside of the ring, by carrying the end connections across to an "active" wire on the other side of the armature rather than to the "dead" wire on the inside.

For a two-pole machine the fundamental element of the drum winding may be taken to be the revolving rectangle of Fig. 452, and the problem is to blend a sufficient number of these together in a continuous winding, with connections to a commutator, so as to deliver currents to the brushes with the same absence of pulsation as obtains in a ring winding with a many-part commutator.

A solution for four rectangles and a four-part commutator is shown in Fig. 465. Starting from the point *a* and following the winding round without reference at first to the commutator, it will be found that the rectangles form a close circuit, and are electrically in series with one another in the order of the numbers marked on them. As regards the connections to the four segments *w x y* and *z* of the commutator, it will be found that at two of these, *x* and *y*,

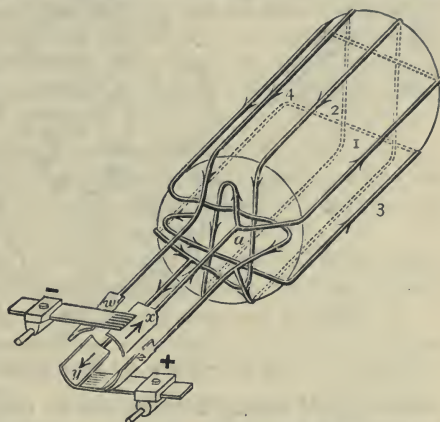

Fig. 465.—Four-Coil Drum Winding.

the pressures in the windings are both directed from (at *x*) or both directed towards (at *y*) the junction with the connecting wire; whilst at the other two, *z* and *w*, one pressure is towards the junction, and the other directed from it. If, therefore, brushes be placed on *x* and *y* they will supply current to an external fixed circuit, whilst for the moment *z* and *w* are idle bars.

In Fig. 466 we have the method applied to an armature with 16 active conductors numbered 1 to 8 and 1' to 8', although for clearness four of these, namely, 2, 3, 2' and 3', are left out in the figure. There is also an eight-part commutator indicated by the heavy lines *a, b, c, d, e, f, g,* and *h*. The polar faces *N, S* of the field magnets (not shown) are supposed to be on the right and left and the direction of rotation clockwise as previously. The diagram shows the connections at the commutator or *front* end; at the far or *back* end the connectors are shown as crossing but, of course, not in contact at *B*.

In tracing connections it must be remembered that all the conductors *descending* on the right-hand side have E. M. F.'s induced in them from *back to front*, whilst in those *ascending* on the left-hand side the induced E. M. F.'s are from *front to back*. Starting from the commutator segment *c*, we can



trace the following path through the armature, viz :  $c\ 5\ B\ 5'\ d\ 7\ B\ 7'\ e\ I\ B\ I\ f\ 4'\ B\ 4\ g$ . It should be noticed that throughout this path wherever we pass along an active conductor we pass in the direction of the induced E. M. F. The whole of these E. M. F.'s are, therefore, in series, with the result that the electric pressure at  $g$  is higher than it is at  $c$ . The other path through the

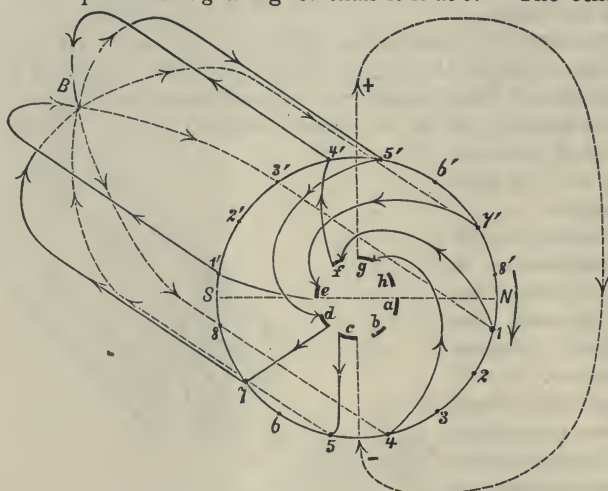

Fig. 466.—Diagram of a Drum Armature.

armature would be as follows, but the connections at the front are not shown in the figure, and four of the conductors are left out :  $c\ 3'\ B\ 3\ b\ 2'\ B\ 2\ a\ 8\ B\ 8'\ h\ 6\ B\ 6'\ g$ . Here again the E. M. F.'s are all in one direction, from  $c$  towards  $g$ . We have, therefore, the same state of things as in a ring-wound armature, with the

result that, if sliding brushes are at the moment touching  $c$  and  $g$ , these brushes will be able to supply current to an external circuit, the current flowing from  $g$  to  $c$  through this circuit and from  $c$  to  $g$  through the armature.

One of the early forms of the drum armature when completed is shown

in section in Fig. 467. An iron cylinder  $s\ s_1\ n\ n_1$  is fastened upon the steel axle  $c\ c$ , which rests in bearings at  $F_1\ F_2$ .

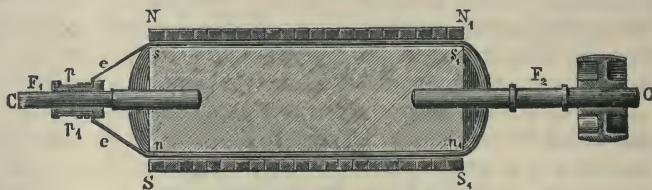

Fig. 467.—The Drum Armature (early form).

Insulated copper wire is wound round the cylinder longitudinally, the ends  $e\ e$  being carried to the commutator  $p\ p_1$ .  $N\ N_1$  and  $s\ S_1$  represent the sections of the magnetic poles. The magnetic poles are cylindrical arcs as regards shape, and surround the drum for more than two-thirds of its circumference.

It will easily be perceived that the inducing action of the magnets with the drum armature is, as we have said, more completely utilised in Siemens'

generators than in Gramme's, for all parts of the wire coils of the armature move in magnetic fields, and no portion is situated inside the cylinder. Hence there is no idle wire except that which crosses the ends of the cylinder. In order to prevent the heating of the iron cylinder by the "eddy" currents already referred to, Siemens and Halske constructed generators in which the iron core of the drum was fixed, and only the wire coils rotate in the magnetic field. In these generators the armature coils were wound on a drum consisting of a sheet of German silver, which rotated round the iron drum, at a little distance from it, and from the enclosing magnetic poles. The idea, though an ingenious one, failed in practical work both on account of the difficulties of construction, and because of the large mechanical forces which act on the wires at full loads. The modern method of avoiding the formation of eddy currents is to laminate the iron, as we have already explained, by building up the core with thin iron discs insulated from one another.

The chief defects of the early drum armatures were—

1. The heating of the machine, particularly when the core of the armature rotated with the coils. The temperature of the armature in this case rose more rapidly than that of the field magnets.

2. Any irregularity in the outer circuit—as, for instance, in an arc lamp that was in use—caused the formation of strong sparks at the brushes, and, therefore, a more rapid wearing away of the commutator and brushes.

3. The convolutions made in the winding, according to the plan of Von Hefner-Alteneck, had, further, the disadvantage of being unsymmetrical, and, consequently, difficult to wind. This unsymmetrical form also favoured the production of sparks at the commutator, in consequence of the absence of electrical equilibrium on opposite sides of the armature, or in the bobbins connected by means of the segments of the commutator. This defect, however, has been remedied in modern machines by improved methods of winding, so that many machines are now drum wound, for such winding has certain advantages as compared with ring winding.

The chief difficulties in drum winding, when the active wires and the commutator bars are numerous, are to design the form of the connectors at the two ends so as to avoid the bunching up and overlaying of the different wires, to improve the insulation between wires at widely different potentials when the machine is running, and to allow of the more ready removal of a faulty section in the event of a breakdown. To meet these and other modern requirements many ingenious schemes have been proposed, to some of which we shall refer in the later section.

**Open Coil Armatures.**—The ring and drum armatures described above have one feature in common, and that is that the windings form a closed circuit in themselves and are quite continuous without any aid from the commutator. But another and entirely different method of fulfilling the electrical requirements has met with a large measure of success. In

machines of this type the armature is wound with a convenient number of separate coils, the ends of which, either singly or in pairs, are brought to the two segments of a corresponding number of two-part commutators. The necessary connections between the coils at different periods of the revolution of the armature are made by suitable brushes sliding on the commutators. Without these brushes the coils or groups of coils are quite separate and distinct with their ends disconnected. Armatures of this type may therefore be called "open-coil" armatures, the ring and drum armatures being examples of "closed-coil" armatures.

To explain clearly this method of armature construction it will be best to take an actual example, and for this purpose we select a machine which has been very largely used, namely, the arc lighting machine made by the Brush Electrical Engineering Company, and usually known as the Brush

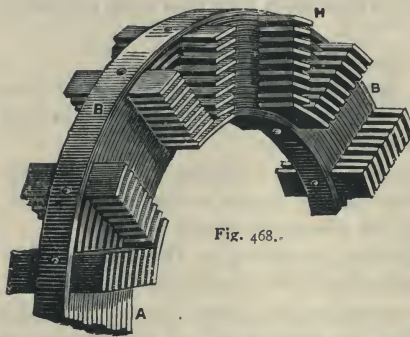

Fig. 468.

Details of Core of Brush Ring.

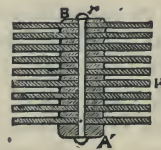

Fig. 469.



Fig. 470.

machine. To avoid repetition later we shall give diagrams taken from a modern example of the type.

*The Brush Armature.*—The core of the armature is in the form of a ring, with depressions at intervals in

which the coils are wound. This core in the more modern machines is built up of thin iron ribbon  $\frac{3}{80}$ ths of an inch thick. The annexed figures (468 to 472) show the principles of its construction, but in the actual machine a much larger number of pieces of thinner iron than is there shown is used. The ribbon is wound upon a circular foundation ring A', and projecting cross-pieces of the same thickness and of the shape shown in Fig. 470 (and also marked H in Figs. 468 and 469) are inserted at intervals to separate the convolutions, admit of ventilation, and form suitable projections between which to wind the coils. In the larger armatures there are 45 turns of ribbon, and these are secured by well-insulated radial bolts r. The concentric grooving which results from this method of building up the ring not only laminates the iron so as to diminish the eddy currents but also ventilates the core, and thus tends to keep it cool whilst running. In the large depressions or grooves thus left the coils of insulated copper wire are wound, until the groove is filled up and becomes flush with the face of the intermediate thicker portions, by which the grooves are separated from one another. This method of winding



the coils is illustrated in Fig. 471, in which, however, the iron of the ring, though similarly built up, is not quite the same in details as is shown in Figs. 468 to 470. The coils are connected in pairs, each to that diametrically opposite it, as shown in Fig. 472, which represents an eight-coil armature, and adjacent coils are carefully insulated from one another. For each pair of opposite coils there is a separate commutator, so that, for the ordinary ring of eight coils, there are four distinct commutators side by side upon the axis—one for each pair of coils.

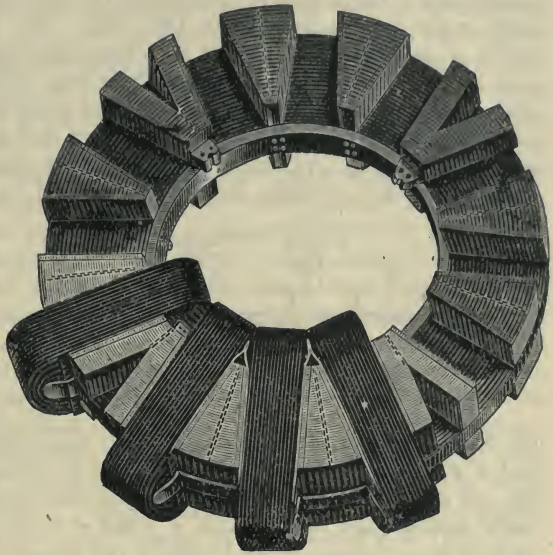

Fig. 471.—Brush Ring partly wound.

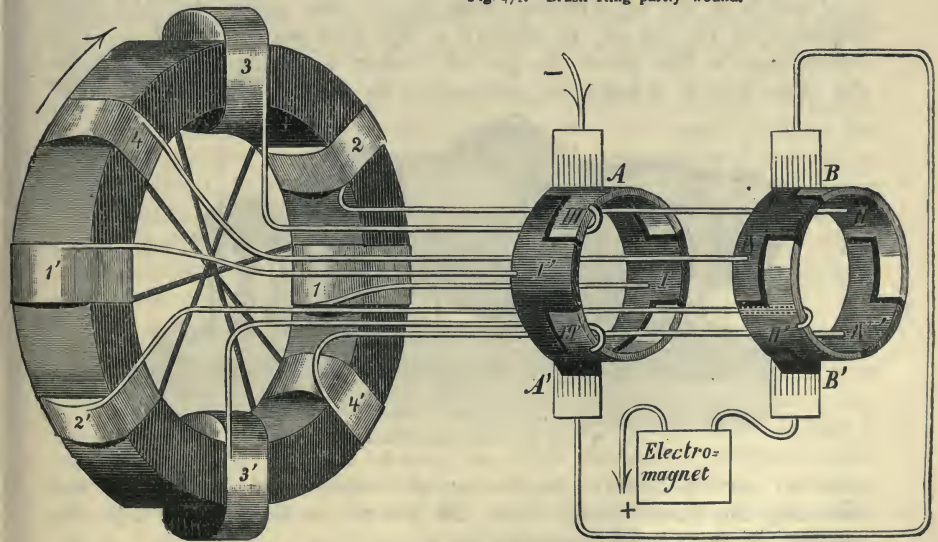

Fig. 472.—Connections of Brush Arc Light Machine.

The brushes are arranged so as to touch at the same time the commutators

of two pairs of coils, but never of two adjacent pairs; the adjacent commutators being always connected to two pairs of coils which lie at right angles to one another in the ring. The double commutators A A' and B B', each of which serves for commuting the current of four of the coils of the armature, are each built of four strips of copper of a special shape mounted on an insulating hub. The strips are shown alternately light and dark in Fig. 472, but their construction and arrangement will be better understood in Fig. 473, which represents the commutator A A' developed or laid out flat. Similar references are used in the two figures. There

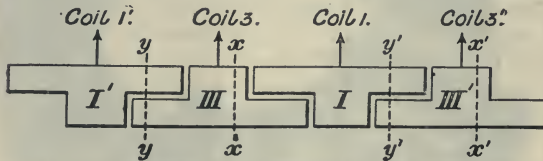

Fig. 473.—Development of the Commutator of the Brush Machine.

are two brushes (Fig. 472) diametrically opposite to one another, and sufficiently wide to bridge the full width of the commutator. Consequently when these brushes lie on the wide pieces of metal in the position indicated by the dotted lines  $x x$  and  $x' x'$  (Fig. 473), the coils 3 and 3' are in circuit, and the coils 1 and 1' are cut out. On the other hand, when the brushes rest on the narrow metal sections, say on the lines  $y y$  and  $y' y'$ , the coils 1, 1' and 3, 3' are in parallel in any fixed circuit to which the brushes lead. The commutators A A' and B B' are so arranged relatively to each other that the wide segments on A A' are 45° in advance of the wide segments in B B'. The consequence is that when one pair of brushes is putting coils in parallel the other pair of brushes has one pair of its coils in series and its other

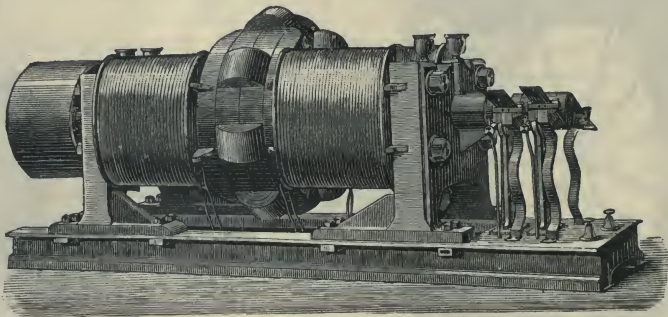

Fig. 474.—The Brush Machine.

pair cut out of circuit. In the position represented in Fig. 472, and assuming the outer circuit closed, the current would flow through the machine in the following manner:—

Brush A, III, 3, 3', III' A', B  $\left\langle \begin{matrix} \text{II. 2. 2' II.'} \\ \text{IV. 4. 4' IV.'} \end{matrix} \right\rangle$  Brush B', Electro-magnets.



The complete machine is shown in Fig. 474, where it will be seen that the electro-magnets are two horizontal two-limb magnets with wide-spread pole-pieces facing one another on either side of the ring and nearly touching it. The pole-pieces are sufficiently large to cover three coils on either side at once; similar poles face one another, so that the lines of force entering on one side pass through the core under and over the axle to the poles on the other side. Thus the pair of coils which is not covered by the pole-pieces is simply sliding along the lines of force and not cutting them, and therefore has no induced E. M. F. It is this pair ( $I, I'$  in Fig. 472) which, whilst thus "idle," is cut out of circuit to be brought in again a moment later when it begins to generate E. M. F. once more. The advantage of thus cutting out the idle coils is that their resistance is removed from the circuit when they are unable to add anything to the pressure, and when therefore their resistance would merely diminish the total current without any counteracting advantage.

For the sake of adjusting the brushes, so as to make contact with the commutators at the most effective angular position with respect to the magnetic field, they are mounted to the opposite ends of two rocking levers, which are capable of oscillating on the driving-shaft, and can be fixed in any desired position by means of a set screw, which clamps a stout wire rising from the base of the machine. The currents are conveyed from the brushes by wide strips of thin sheet copper, shown in the general view (Fig. 474), and in order to allow for the variable distance of the free ends of the brushes from the base of the machine they are made undulating or wavy, doubling up as the distance is shortened, and stretching out when it is increased.

Another widely-used machine with an open-coil armature is the Thomson-Houston dynamo, which we shall describe later. In all such machines the object of the open winding is to enable different combinations of the coils of the armature to be made by the sliding brushes at different positions during a revolution, and the combinations sought are those which will conduce to the highest efficiency and steadiness of the current, the idle coils being frequently cut out. Another object sometimes attained is the regulation of the current so as to satisfy different working conditions.

#### IV.—FIELD MAGNETS.

In no direction do the principles of the "Magnetic Circuit," which we have discussed on pages 282 to 284, find a more pertinent application than in the design of the magnetic parts of dynamo-electric machines. Indeed it was the pressing practical necessity for some method of calculation more convenient than was offered by polar theories of magnetism that led Dr. Hopkinson and his co-workers to develop these principles. This development of the theory was quickly followed by a great improvement in the design of dynamos, and largely contributed to the improved efficiency and output of modern machines, and to their great increase in size, as



compared with those produced in the first years following the invention of the Gramme ring and the drum armature. Although this section is headed "Field Magnets," it is to be understood that under that title the whole magnetic circuit of the machine is to be discussed.

The primary object of the magnetising coils of a dynamo machine is to produce economically a large magnetic flux through some definite part of the magnetic circuit. It has been already pointed out that to maintain a magnetic flux when once set up does not require any expenditure of energy, but that, on account of the imperfections of our electrical conductors, when the flux is being maintained by the magneto-motive force of a magnetising coil, energy is spent in keeping up the current in the electric circuit. In dynamo machines we have to deal with large electro-magnets and large magneto-motive forces. It therefore becomes of primary importance so to dispose of the copper of the magnetising coils and the iron of the magnetic circuit that the magneto-motive force exerted by the current on the coil shall produce the effect required with the least expenditure of energy in the electric circuit. Of course, other considerations, such as ease and economy in construction, mechanical strength and rigidity under working conditions, etc., etc., have to be borne in mind, but in attending to these the principles to be observed to secure a good and economical electro-magnet must not be overlooked.

Especially must it be borne in mind that magnetic lines, which do not pass through those parts of the machine where useful inductions are taking place, are wasted and therefore lower the efficiency of the machine. They are technically known as "leakage" lines, and the amount of "magnetic leakage" at different loads is an important factor in the working of any machine. When it is stated that even in well-designed machines, for every 100 lines usefully employed as many as 130 lines have to be set up in the cores of the magnetising solenoids, the importance of the "leakage coefficient," as it is called, is easily understood.

The fundamental rules of the magnetic circuit have already been stated (*see* page 283), and we can therefore proceed directly to illustrate their application to dynamo machines by actual examples.

In Fig. 475 are shown the forms of the magnetic circuits of various pioneer types of dynamo machines. In these diagrams the iron of the field-magnet proper is shaded full black, whilst the iron of the armature is only lightly shaded; in most of the figures the axis of rotation is perpendicular to the plane of the paper, but in *d* and *f* it is parallel to that plane, and is indicated by a dotted line. Joints in the iron of the field-magnet are indicated by white spaces, and the wires of the magnetising coils are shown in section as rows of dots.

Fig. *a*<sub>1</sub> represents one of the early Edison machines, and *a*<sub>2</sub> the same machine after it had been improved by Dr. J. Hopkinson, and then known as the Edison-Hopkinson dynamo. Notice how the comparatively long thin cores

and light yoke of  $a_1$  are replaced by shorter and thicker cores and a more massive yoke in  $a_2$ . It is easy to see how the *magnetic reluctance* of the circuit of  $a_2$  must be less than that of  $a_1$ , both because the length of the path is shorter and also the cross section of the iron greater. The shape of the pole-pieces and the cross section of the iron of the armature tend further to diminish the reluctance of  $a_2$  as compared with  $a_1$ . Again, it should be noticed how the shape of the pole-pieces in  $a_1$  encourages magnetic leakage. It is easy to see that in the earlier machine more lines will pass from one pole to the other

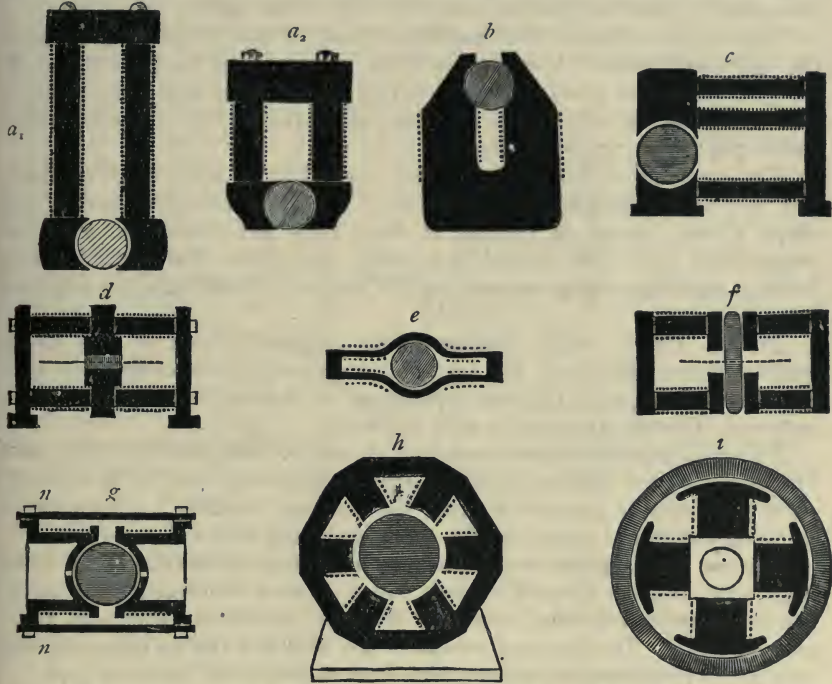

Fig. 475.—Magnetic Circuits of Various Dynamos.

without entering the iron of the armature. All such lines are useless for the purpose for which the electro-magnet is intended.

Fig. 475 *c* represents the magnetic circuit of another early form of Edison dynamo, known as the "Jumbo," which was one of the first machines used for public street lighting in London. The machine itself will be found described in a previous edition of this book. There were as many as eight magnetising solenoids arranged in two groups in parallel. The magnetic leakage of such an arrangement is excessive, as we shall show presently. Fig. 475 *b* represents a simple and widely-used form of magnetic circuit, the

machine being known as an "overtype" one. The iron of the field-magnet is forged in a single piece, and there are no joints to increase the magnetic reluctance. The effect of such joints is very appreciable in several of the machines illustrated.

In the foregoing machines  $a_1$ ,  $a_2$ ,  $b$ , and  $c$  the magnetic circuit is a single one; that is, the lines of force all circulate round in the same direction. Double magnetic circuits are shown in Figs.  $d$ ,  $e$ , and  $f$ ; in these there are two distinct paths for the magnetic lines which unite at the north-seeking pole-piece to pass through the armature to the south-seeking pole-piece.

Fig. 475  $d$  represents the magnetic circuit of one of the early forms of the Gramme dynamo. It consists in effect of two electro-magnets united by the pole-pieces, the electro-magnets having similar poles facing one another. The yokes and cores shown are too thin and long for a good magnetic circuit, and in this respect are worse than  $a_1$ .

Fig. 475  $e$  shows the carcass of the original drum machine of Siemens. The iron of the field-magnet consisted of a number of forged bars of the shape shown, united in parallel at their ends and overwound with the magnetising coils. No special pole-pieces were used, the central spaces between the magnetising coils serving this purpose. Here again the magnetic circuit is poor.

In Fig. 475  $f$ , which represents the magnetic circuit of the Brush machine already described, the two electro-magnets are separated and each has its own pole-piece, the two pole-pieces at the top being similar to one another. The armature ring is seen edgewise.

Fig. 475  $g$  represents the somewhat remarkable magnetic circuit of the Thomson-Houston dynamo, which we shall describe fully later. The external pieces  $n$  are rods of iron which make the machine resemble a squirrel cage, enclosing a spherical armature with the magnetising coils and pole-pieces.

The last two diagrams  $h$  and  $i$  represent multipolar machines. In  $h$  the magnet has six poles directed inwards from a massive continuous outer yoke. The magnetising coils are wound on the polar projections, which are alternately N and S. The armature rotates in the centre of the six poles, and the wires on its periphery cut the magnetic lines as they cross the polar gaps.

In  $i$  the previous machine is, as it were, turned inside out, except that the number of poles has been changed from six to four. The field-magnet has been placed inside the armature and the revolving armature outside. In this case it is the *inner* wires of the ring-wound armature that are active and the outer ones idle. The machine is one of Siemens and Halske's design.

The above examples will be sufficient to familiarise the reader with some of the typical early forms of the magnetic circuits of dynamos and to draw attention to the salient considerations underlying good design. In the sequel other forms will be fully dealt with in connection with descriptions of the machines themselves.

**Magnetic Leakage.**—In connection with the important subject of mag-



netic leakage, the reader should compare Figs. 476 and 477, which represent extreme cases on either side. Fig. 476 depicts the result of a research by Hering on the leakage field of the Edison "Jumbo" dynamo already referred to in Fig. 475*c*. For clearness none of the useful lines are drawn, the diagram only showing the general disposition of the waste or leakage lines. When the machine is fully excited the whole of the space in its neighbourhood is strongly permeated with magnetic lines of force passing in the directions indicated by the arrows. It will be remembered that the magnetising coils are disposed unsymmetrically, there being a greater number at the top than at the bottom. The figure shows two upper and one lower core. The waste consequent on putting similar cores in parallel is shown by the fact that a magnetic field was found between the two upper cores. Incidentally it may be remarked that dividing up the iron in this way requires a far greater length of conducting wire to provide the same number of effective ampère-turns. When the different M. M. F.'s are in parallel, the effective M. M. F. is only the same as could be produced by a single coil. The wire of such a single coil, surrounding a single cross section of core equal to the added cross sections of the separate cores, would obviously be much shorter than when the cores are separate, whilst the magnetic reluctance would be the same.

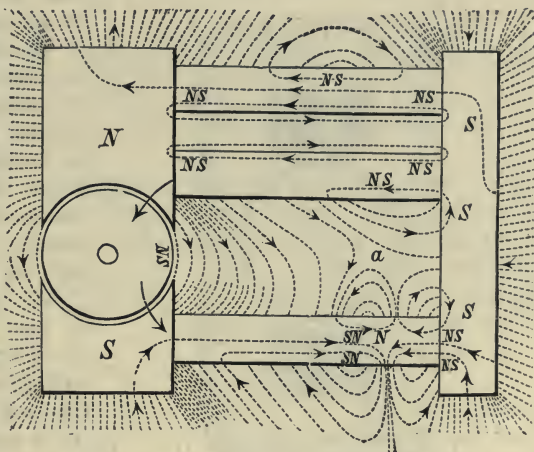

Fig. 476.—Magnetic Leakage in early form of Dynamo.

A very cursory examination of the figure convinces one that a very large proportion of the M. M. F. of the magnetising coils is being spent in maintaining lines of force that are useless for producing E. M. F.'s in the wires of the rotating armature.

Contrast all this with Fig. 477, which represents an iron-clad Eickemeyer dynamo, built in accordance with a suggestion made by Forbes. In this machine there is only one magnetising coil *ff*, which is wound over the armature. The coil and armature are surrounded by the iron of the field-magnet, hence the term "iron-clad." The reason for Forbes' suggestion is that as the primary object of the magnetising coil is to pass lines of force through the armature it will be in the best position to effect this when wound as shown in the figure. In this view of the matter the remainder of

the iron, namely, that not contained in the armature, is introduced merely for the purpose of reducing the reluctance of the path that the lines must follow in completing their circuit round the magnetising current. A few lines are drawn as passing through the air, but these are not leakage lines in the proper sense of the term, for their path also is in series with the armature, through which they pass and produce their full effect on the E. M. F. of the machine.

**Magnetic Reactions.**—By Lenz' law the currents induced in the armature of a dynamo must be in such a direction as to tend to retard the operations which generate them, namely, the 'cutting by the conductors of the armature of the lines of force set up by the field magnet. The only way in which the currents can so operate is through the medium of the magnetic effect they produce. This magnetic effect must, therefore, be such as to retard the relative motion of the conductors and the field.

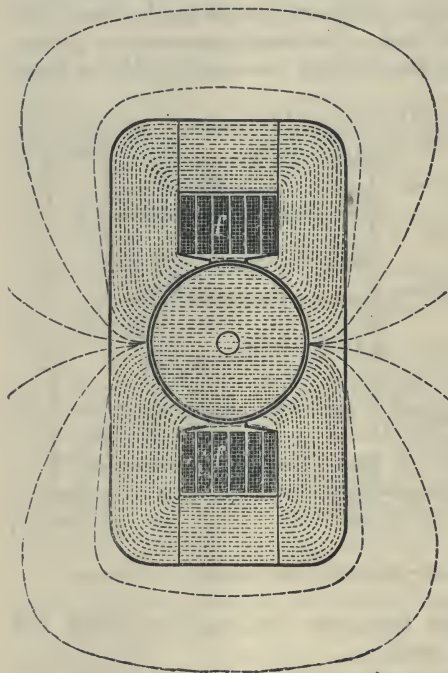

Fig. 477.—Magnetic Flux in modern Iron-Clad Dynamo.

We should, therefore, expect to find that the field set up by the currents in the armature interfered in some way or other with the field due to the field magnets. As a matter of fact, the former field is superposed on the latter, and, therefore, there must be a change in the magnetic flux through the armature either in magnitude or direction, or both.

An examination of the fundamental experiments on magneto-electric induction shows that in them the induced currents interfere with the field which is an essential factor in their generation. In Fig. 386 the approach of the magnet generates currents whose field weakens the field due to the approaching magnet; whilst, when the magnet is receding, the field set up by the currents tends to strengthen the field due to the magnet. Similar observations, which the reader can work out for himself, apply to the experiments connected with Fig. 387.

The case of the magnetic, or, as they are usually called, the *armature, reactions* in a dynamo is more complex, and the polar theory of magnetism

cannot assist us very much in examining it. It, however, becomes fairly simple when considered by the aid of lines of force.

We have in Fig. 458 given a diagram of the magnetic field passing through the armature of an ordinary two-pole continuous current dynamo, it being supposed that there is no current in the armature wires, and that, therefore, the electro-magnets are excited from a separate source. Fig. 478 shows the converse case in which, the field magnets being unexcited, a current from a separate source is passed through the armature in the direction in which the induced currents would flow if the machine were in action. Remembering that the currents on the right-hand or descending side will be flowing from the spectator, whilst those on the left-hand or ascending side will be flowing towards the spectator, it is easy to see that the field produced will pass vertically upwards through the iron and return outside the conductors in some such paths as are indicated in the figure.

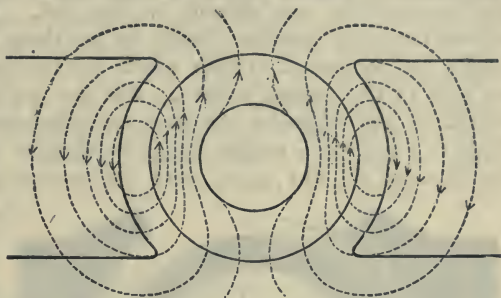

Fig. 478.—Field due to Armature Current only.

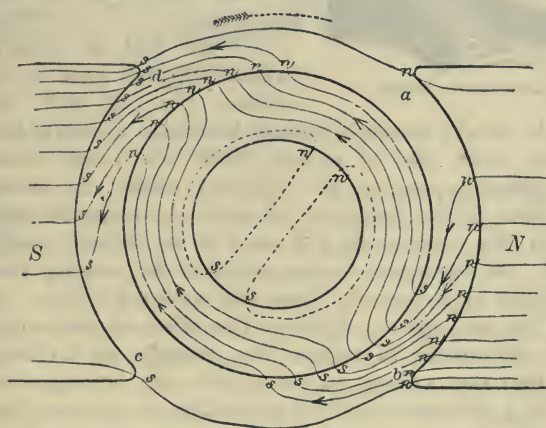

Fig. 479.—Twisted Field due to Magnetic Reaction of Armature.

the iron and return outside the conductors in some such paths as are indicated in the figure.

Let this field now be superposed on the field shown in Fig. 458, and the result will be, in a general way, that depicted in Fig. 479. At the leading horn *a* of the *N* pole-piece the two fields are oppositely directed, with the result that the field-magnet field is more or less weakened ;

whilst at the trailing horn *b* the two fields are in the same direction, and the resultant field is strengthened. Similar effects occur at the *s* pole-piece, the field under the leading horn *c* being weakened and that under the trailing horn *d* strengthened. The effect may be summed up by saying that the field of the dynamo is twisted round in the direction



of the rotation of the armature. The results are shown as mapped out by iron filings in Fig. 480. Some important consequences, which we shall now briefly discuss, follow from this superposition of fields.

*Lead of the Brushes.*—Since the field has been twisted round in the direction of rotation the proper position for the brushes is no longer the symmetrical one shown in Fig. 458. The theory there set forth shows that the brushes should be on those sections of the commutator which are connected to coils which are not cutting lines of force, that is, to coils in the *neutral position*. But the neutral position has been shifted round by the magnetic reactions, and, therefore, the brushes must follow. This will lead to a further slight twisting of the field, which must again be followed up, and so on until the brushes



Fig. 480.—Twisted Field as shown by Iron Filings.

come into the true neutral position, which they can catch up, because the field, due to the armature, is much weaker, even at full load, than that due to the field magnets. In fact, for sparkless commutation, as we shall show in due course, the brushes must be advanced a little past the neutral position.

If the field be much twisted at full load it is evident that at half or quarter load it will not be nearly so much twisted, hence the necessity for mounting the brushes in some kind of *rocking* device which will allow them to be fixed in different positions for different loads. In some modern dynamos one object of the design is to make the angle of lead at full load so small that the brushes do not need to be shifted much as the load varies. This can obviously be accomplished by making the field-magnet field very much more powerful than the armature field.

*Demagnetising and Cross-magnetising Effects.*—The effect of the twisting of the field may be represented in another way, namely, by dividing the disturbing currents into two groups, one of which may be regarded as having, on the whole, a *demagnetising* effect, tending to *weaken* the field due to the field magnets; and the other, a *cross-magnetising* effect, tending to produce a field at right angles to the other. This method of analysing the phenomena has been very prettily illustrated in a diagrammatic form by Dr. S. P. Thompson, to whom Figs. 481 and 482 are due. In these figures the small circles represent the cross-sections of the conductors; the circles with a dot in the centre are conductors carrying currents towards the spectator, the dot representing the point of an

approaching arrow; whilst the circles with crosses, which represent the feathers of retreating arrows, are conductors carrying currents away from the spectator. The line  $nn'$  (Fig. 481) is the diameter passing through the position of the brushes, and it is in passing this line that the currents are reversed in the conductors. The lines  $bc$  and  $ad$  are drawn at right angles to the line of the poles  $NS$ , through the points where  $nn'$  cuts the outer circle of the iron. Now the eight conductors, four at the top and four at the bottom, between  $bc$  and  $ad$ , will set up a field directly opposed to the principal field  $NS$ ; this is, therefore, a demagnetising field; it is represented by the horizontal lines in Fig. 482. The other 24 conductors, twelve on each side, produce a vertical field upwards at right angles to the field of  $NS$ ; this cross-magnetising field is represented by

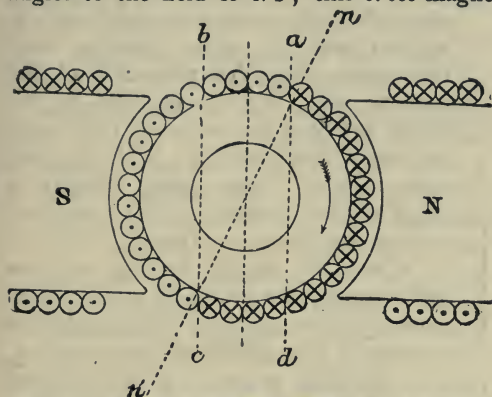

Fig. 481.—Analysis of the Magnetic reaction of the Armature Currents.

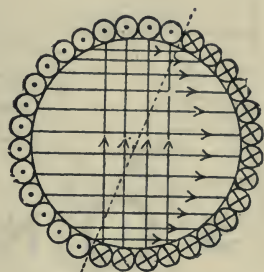

Fig. 482.—Demagnetising and Cross-magnetising Fields of Armature.

the vertical lines in Fig. 482. It may seem somewhat arbitrary thus to divide the currents without reference to the sequence in which they follow one another in the actual circuit, but it is quite justifiable; for the physical effect of the currents in any position is quite independent of the connections by which they arrive at that position, and for purposes of illustration or calculation they may be grouped in any way consistent with the conditions and without reference to the connections, provided the magnetic effect of the latter may be neglected.

The chief result obtained is that the demagnetising effect increases with the number of conductors between  $bc$  and  $ad$ —that is, with the angle of lead—and also with the current these conductors carry—that is, with the load on the machine. Its value in *ampere turns* may obviously be found by multiplying half the number of conductors by the current carried by each, all these currents being equal to one another.

**Magnetising Coils.**—We come now to the position and connections of the magnetising coils. An examination of Fig. 475 will show that these

coils may be so placed in two-pole machines that the M. M. F.'s produced are either in series in the magnetic circuit (Figs. *a*<sub>1</sub>, *a*<sub>2</sub>, *b*, *c* and *g*) or partly in series and partly in parallel (Figs. *d*, *e* and *f*). In other forms, not shown in the diagram, single magnetising coils are used, or the M. M. F.'s of two coils may be simply in parallel. In four-pole machines nearly every possible position has been used, whilst in multipolars they may be placed on the polar extensions (Figs. *h* and *i*), or on the yokes. In fact, the position chosen for the coils is largely controlled by convenience for winding, the exigencies of manufacture and other considerations having more effect on the general design of the magnetic circuit.

Turning from the position of the coils in the magnetic circuit to their electrical connections, we first observe that the excitation produced in a given magnetic circuit depends upon the *ampere turns* (see page 281) of the exciting coil. It can, therefore, be obtained (*a*) by a few turns of thick wire carrying a large current; or (*b*) by many more turns of finer wire carrying a much smaller current; or (*c*) by any convenient combination of these.

Where the current is large and the turns few, it must obviously be the whole current of the machine. This method of connection is known as the *series* method, since the field magnet coils are in series with the outer or "main" circuit of the machine, as shown in Fig. 483. It is a matter of indifference whether the coil be joined to the positive brush, as in the figure, or whether it be placed next to the negative brush, or split into two coils, one connected to each brush.

But instead of the *series* arrangement we may excite the magnets by a circuit which is a *shunt* on the outer one. This shunt arrangement is shown in Fig. 484; the currents divide at *b*, one branch flows through the coils of the magnets, the other branch flows through the outer circuit to *b*<sub>1</sub>, where the two branches unite again and return to the armature. We know that in divided conductors the magnitude of the current in the different branches is inversely proportional to the resistances in these branches. Therefore, when the resistance in the outer circuit is increased, a larger proportion of the current will flow into the coils of the magnets; when the resistance decreases, the current in the coils of the magnets will also decrease.

The third method (*c*) of connection, known as *compound* winding, in

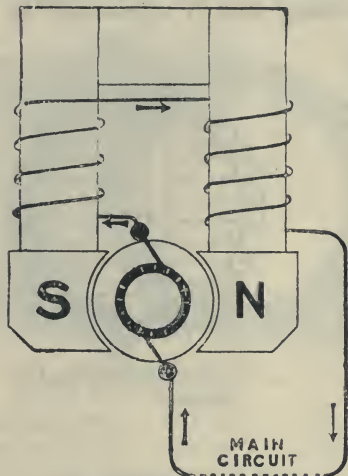

Fig. 483.—A Series Dynamo.



which both *shunt* and *series* coils are employed, is chiefly used where it is necessary to keep the P. D. of the brushes constant through wide variations of load in the outer circuit. Its details will, therefore, be more appropriately discussed when we are dealing with questions of regulation. By its means the demagnetising effect of the armature may be counteracted.

#### V.—ELEMENTARY THEORY OF THE CONTINUOUS CURRENT DYNAMO.

There are two chief methods by which one may examine the relations between E. M. F., current, power, resistance, etc., in the circuits of a dynamo machine, namely, either (*a*) graphically or (*b*) analytically. We shall use both methods, but as the former, the graphic method, is perhaps more easily followed we shall commence by exhibiting a few interesting properties by its aid.

**Graphic Diagrams.**—In order to examine the behaviour of a machine an excellent method, and one easily applied, is to plot out a diagram of measurements on squared paper, *i.e.*, to make a graphic representation of the quantities which are characteristic of the machine. As a rule the squared paper only allows *two* principal quantities to be represented directly, but by a proper choice of these, and taking advantage of known laws, other quantities connected with the principal two may be deduced or even graphically calculated.

The general method of representing the theory of dynamos by means of graphic diagrams was developed by Hopkinson in 1879, and has been further worked out by Deprez, Frolich, S. P. Thompson, and others. As the curves are drawn from observation and actual measurements they serve both as checks and illustrations of conclusions arrived at by means of mathematical analysis, and also have led to further conclusions which cannot well be otherwise obtained. To the curves we are now going to discuss Deprez gave the name of *characteristics*.

**Characteristic Curves.**—Take a dynamo machine and magnetise the field-magnets by a current from another machine, *i.e.*, let it be separately excited. Rotate the armature at a *definite speed*, and measure the electromotive force produced. If the exciting current round the field-magnets be varied, the strengths of the magnetic field will be correspondingly varied, and a given potential difference  $e$  at the terminals of the armature will correspond to each value  $c$  of the exciting current. If we now plot the different values of  $c$  in the exciting circuit horizontally, and  $e$  in the

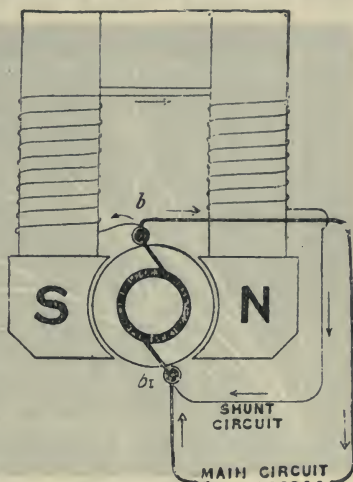

Fig. 484.—A Shunt Dynamo.

induced circuit vertically, a curve termed the characteristic curve connecting these quantities will be obtained, the form of which depends on the construction of the machine.

If we now arrange the machine as a *series dynamo*, by connecting the armature and field-magnets in series, then we obtain the characteristic curve under the condition that the current produced is the same as that which excites the field-magnets, and which also will produce armature reactions. Measurements are to be taken of the simultaneous values of the current and the P. D. at the terminals of the machine, whilst the resistance in the main circuit is varied. From these measurements the curve *A F D* (Fig. 485) is to be plotted, and when once constructed for any definite speed it will

enable us to find the particular value of the current represented by *A E*, which corresponds to a given P. D. represented by *E F*, or *vice versa*.

If the electromotive force *E* and the strength of current *C* be known the resistance can be determined graphically by means of Ohm's law. Thus at the point *G* of the curve *A G C* (Fig. 485), which gives the relation between the E. M. F. of the machine and the current,

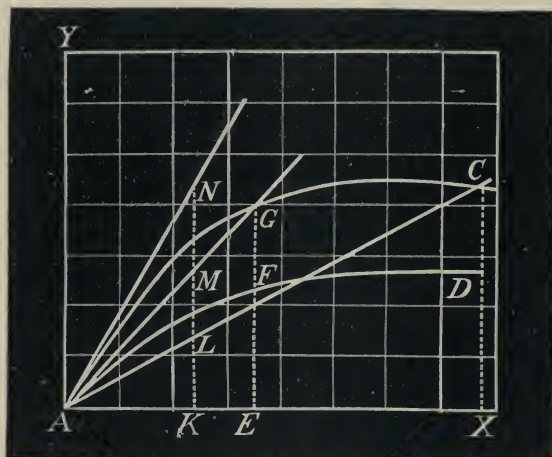

Fig. 485.—Characteristic Curves.

$$E = C \times R, \text{ or } R = \frac{E}{C} = \frac{G E}{A E} = \tan G A E.$$

Thus the total resistance is expressed by the tangent of an angle which can be graphically constructed.

In a similar manner by means of these graphic methods many problems relating to dynamo machine circuits may be solved. If, for example, we start with a definite resistance and gradually diminish it, the line *A G*, the inclination of which measures the resistance, will have to be drawn at a gradually diminishing inclination to *A X*, in the direction *A C*. On comparing the values of *G E* for different positions of *G*, it will be seen that the value of *E* at first increases rapidly, then more slowly, and finally remains constant, or slightly falls. If we now increase the resistance the line *A G* approaches the vertical axis, and will cut the curve nearer and nearer the origin *A*, and at the position *A N* will be a tangent to the

curve. With the resistance in circuit equal to or exceeding the resistance represented by this limiting position, the machine will not produce a current at all; in other words, for these resistances the machine is not self-exciting, it cannot "build" up its magnetism.

Draw the line  $AM$  so that the total resistance  $R = \frac{M K}{A K}$ . Then producing  $AM$  to  $G$ , and drawing  $GE$  vertically, we find that with this particular value of  $R$  the current  $c$  produced will be equal to  $AE$ , and the E. M. F. will be

$$E = GE = A \cdot E \frac{GE}{AE} = C \times R.$$

We also find that  $FE$  will be the P. D. at the terminals when this total resistance is in circuit.

**Commutator Curves.**—Another important graphic diagram is formed by plotting out the difference of potential between one brush of the current collector, and each of the bars of the commutator. In a well-constructed dynamo-electric machine the several parts are traversed by currents which come from the negative brush and traverse the two divisions of the winding, and meet in that piece of the commutator which touches the positive brush. Every division or bobbin of the armature adds its electromotive force to that of the preceding one, and therefore increases the E. M. F. of the circuit. If, now, the potential between the negative brush and the succeeding sections of the commutator be measured, it will be found that it increases regularly in both directions, linearly on the commutator, and attains its maximum at the opposite side, where the positive brush is. This can be proved experimentally by the aid of a suitable galvanometer, one pole of which is attached to the negative brush, while a flexible piece of copper is attached to the other pole, and with it the several radial pieces of the commutator are touched in succession. If the several observed differences of potential be graphically recorded on a drawing of the periphery of the commutator, a diagram like that given in Fig. 486 will be obtained. In this way we can observe the regular growth of the potential from the lowest point of the circle, which represents the negative brush, up to the maximum of the positive brush. If these graphic values are represented on a straight line, which will be equivalent to imagining the periphery of the commutator as unrolled upon a plane, the diagram represented in Fig. 487 will be obtained. This shows that the potential does not increase regularly between the neighbouring segments; if it did, the curves would resolve themselves into two straight lines. In reality, the increase of potential proceeds most slowly in the neighbourhood of the two brushes, and the rate of increase is greatest at the point about  $90^\circ$  from the brushes. It is there that the bobbins

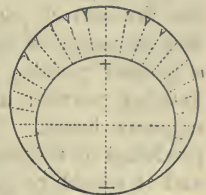

Fig. 486.—Difference of Potentials on a Commutator of a Gramme Machine.



of the armature pass the part of the magnetic field which exerts the greatest inductive action. If the magnetic field were entirely uniform, the number of lines of force cut by the wires rotating in the field would be proportional to the sine of the angle which the plane of the bobbin makes with the direction of the magnetic lines of force. This is nearly the case represented in Figs. 486 and 487.

The measurements relating to the division of the E. M. F. at the commutator are of great practical interest. They not only show where the brushes should be placed in order to gain the best effect, but enable us to compare the efficiency of the windings in various parts of the magnetic field. If the brushes are located at the wrong place, or if the pole-pieces of the field-magnets have a wrong shape, the rise

of the potentials at the commutator will be irregular, and maxima and minima will be observed at other points than those where the brushes touch the commutator. An actual diagram of the relations of the potentials at the collector of a machine of faulty construction is shown in Fig. 488. It is transferred to a horizontal line in Fig. 489. By these diagrams it will be seen that the division of potential at the commutator is irregular, and so much so that one portion of the commutator has a greater positive potential than the positive brush, and another portion a greater negative potential than the negative brush. Therefore one portion of the E. M. F. produced by the machine is destroyed by another portion; and it would be possible to lead off another current by another pair of brushes placed so as to touch the commutator at these points of maximum and minimum potential.

**Characteristic Curves of Various Machines.**—In Fig. 490 we have brought together for comparison the characteristics of various types of machines, each characteristic expressing the relation between the P. D. of the machine and the current in the external circuit. Such characteristics are called "*external characteristics*," and they are the ones of most interest to the user of the machine, for they tell him exactly what to expect in the external circuit. Each curve is drawn for the normal speed, which is supposed to be kept constant.

In these diagrams the current  $c$  in the external circuit is measured horizontally in the direction  $o c$ , and the P. D. ( $v$ ) at the terminals of the machine is measured vertically in the direction  $o v$ .

The first curve  $A P p$  represents the external characteristic of a machine with *permanent magnets* or of a *separately excited* dynamo, in which the

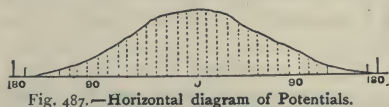

Fig. 487.—Horizontal diagram of Potentials.

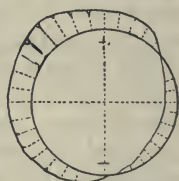

Fig. 488.—Potentials with a Commutator of a badly designed Dynamo.

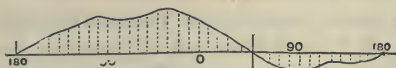

Fig. 489.—The same horizontally.

exciting current is kept constant. The point A represents the P. D. at the terminals when there is no current in the outer circuit; this is the full E. M. F. of the machine. As the current in the outer circuit increases the P. D. falls slightly because the volts ( $c r$ ) "lost" in the machine increase with  $c$ , the resistance  $r$  of the machine remaining constant. This fall is a simple consequence of Ohm's law; it continues regularly along a straight line to P.

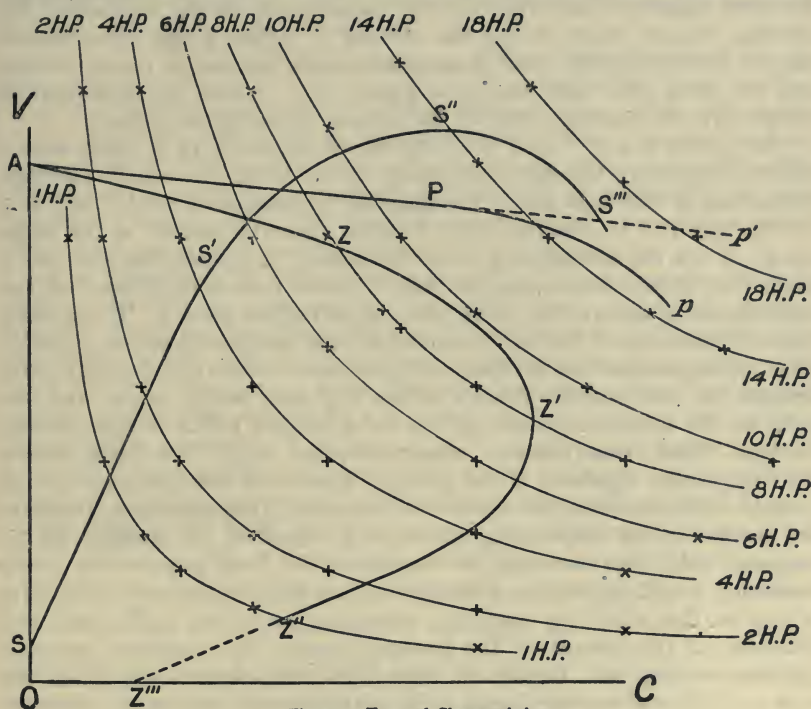

Fig. 490.—External Characteristics.

After P, instead of continuing along the straight line to  $p'$ , the P. D. drops more and more rapidly to  $p$ , showing that some other effect is being produced. This more rapid fall is due to a diminution of the E. M. F. of the machine caused by the demagnetising effect of the now large current in the armature wires; this weakens the field, and consequently decreases the E. M. F. The experiment stops at  $p$ , as the machine will not carry more current without overheating.

The next curve  $s s' s'' s'''$  is that of a *series* dynamo. The P. D. ( $o s$ ) on open circuit is due to the residual magnetism of the machine, owing to which the curve does not start from the origin  $o$ . With a very large resistance in the outer circuit, as has already been pointed out, the magnetism will not

"build," and the  $v$  and  $c$  remain very small. As the resistance is gradually diminished, a critical value is reached which if very slightly reduced will cause the machine to "build" rapidly, the  $v$  quickly rising to the value indicated by  $s'$ . After this the rise is less rapid owing to the iron becoming almost saturated, until at  $s''$  the curve becomes horizontal because the increasing value of the lost volts and the influence of the current in the armature together counterbalance any increase due to the increase in the exciting current which is also the current  $c$ . Past  $s''$  the above-named adverse influences more than counterbalance the increase in the excitation, and the curve falls more and more rapidly to  $s'''$ , where the experiment is stopped by the heating effect of the current becoming dangerous.

The curve  $A z z' z'' z'''$ , the external characteristic of a *shunt* wound dynamo, is perhaps the most interesting of the three, as it shows a curious interaction of electrical laws. The electrical connections are as in Fig. 484, in which it will be observed that whether there be current in the outer circuit or not the magnetising circuit is closed. It follows that even when there is no current in the outer or "main" circuit there is full pressure at the brushes, and, therefore, the curve starts at its highest point  $A$ . If the main circuit be then closed through a somewhat high resistance which is gradually reduced, the pressure falls with the first increases of the current  $c$  along a fairly straight line, the droop in which is at the beginning mainly due to the lost volts in the armature caused by the extra current which is now passing through. Other causes, however, come more or less quickly into play to disturb the straight line regularity of the droop. The first is that the mere drop of pressure at the brushes due to the extra lost volts in the armature diminishes the current in the magnetising circuit, and, therefore, the strength of the magnetic field, thus reducing at its source the total pressure (E. M. F.) available. It will depend upon the part of the magnetising curve (Fig. 252) in use at the time how soon this disturbing cause will make itself felt. Secondly, as the current in the armature grows, the magnetic reactions increase, tending still further to weaken the field and to cut down the E. M. F. These disturbing causes make their existence felt more and more rapidly as the external resistance is reduced, and the curve falls with increasing slope until at  $z'$  it tumbles sheer over. If the experiment be continued and the resistance in the main circuit still further reduced, the curve turns back in the direction  $z'' z'''$ . At this stage, unless the dynamo be driven very steadily at a dead constant speed, it is very difficult to obtain readings, for the conditions tend to instability, but by careful working the curve may be traced to the neighbourhood of  $z''$ , below which all serviceable magnetising current is practically drained out of the electro-magnets, and the machine ceases to act as a dynamo. It is curious to note that the latter part of the curve, which is fairly straight, is not directed towards  $o$ , but towards a point  $z'''$  well to the right of  $o$ .

*Power Lines.*—We have already shown (Fig. 485) how the resistance corresponding to any point on the diagram may be graphically obtained, but



an even more important quantity, namely, the electrical horse-power (E. H. P.), can be indicated readily on the diagram. For this purpose a series of curves must be drawn having the property that for every point on any particular line the product of amperes  $\times$  volts shall be the same. We have already explained that the product of *amperes*  $\times$  *volts* gives the electrical power in *watts*, and, remembering that 746 watts are equivalent to the engineers' "horse-power" (see page 379), we have

$$\text{Electrical Horse-Power} = \frac{\text{volts} \times \text{amperes}}{746}$$

Such curves have been drawn, and are shown in light lines in Fig. 490 for 1, 2, 4, 6, 8, 10, 14 and 18 E. H. P., the value of the power for each curve being marked at the two ends. By means of these curves one can readily determine the points of the various characteristics at which any of these powers are being used in the external circuit, and for intermediate powers the points can be indicated approximately by interpolation.

It is interesting to note how the shapes of the various characteristics indicate the maximum power that the machines can exert in their main circuits. Thus, for the shunt dynamo, whose curve  $A z' z''$  is given, the power in the main circuit at the speed of the experiment can never quite reach 10 H. P. For powers below this there are two points on the curve at which the same power is exerted. The series dynamo curve  $s s'' s'''$  reaches its maximum power at a little over 16 H. P., after which it begins to curve away from the neighbouring power line. The separately-excited dynamo curve  $A P \rho$  begins to turn back on the adjacent power line at about 15 H. P.

**Calculation of E. M. F.**—Turning now to symbolical methods, it has been shown (page 483) that the average rate of cutting magnetic lines by a wire revolving at a speed of  $n$  revolutions per second in a two-pole field of useful flux  $N$  is  $2 n N$ , corresponding to a pressure of  $\frac{2 n N}{10^8}$  volts. To avoid cumbering the equations we shall omit the divisor  $10^8$ , as it is not likely, because of its magnitude, to be overlooked in any actual calculation.

In a two-pole dynamo, whether ring or drum wound, let the total number of active conductors on the outer periphery of the iron core be  $z$ . These conductors are the only ones in which any E. M. F. is generated, the remainder of the winding in either class of armature merely serving to make the necessary electrical connections. Moreover, these  $z$  conductors are at any instant electrically divided into two equal groups, the members of each group being joined in series, and the two groups being in parallel. The E. M. F. of the combination is, therefore, the E. M. F. of either group of  $\frac{z}{2}$  conductors, and, denoting the E. M. F. by  $E$ , we have,

$$\begin{aligned} E_{(\text{mean})} &= \frac{z}{2} \times 2 n N \\ &= n z N, \end{aligned}$$

which is one of the fundamental equations of this type of dynamo.

**Application of Ohm's Law.**—(1) *Series dynamo*; let  $E$  be the whole electromotive force of the dynamo, and let  $v$  be the difference of potential between the terminals to which the exterior circuit is attached. Then  $v$  is less than  $E$ , for part of the electromotive force is expended in driving the current through the resistance in the armature. The volts by which  $v$  falls short of  $E$  represent the part of the E. M. F. unavailable externally, and are therefore sometimes called the *lost volts*.

Let  $R$  be the resistance of the outer circuit, and  $r_a$  that of the armature, also let  $c$  be the strength of a current. Then Ohm's law gives us:—

$$E = C(R + r_a)$$

$$V = C R$$

and therefore  $E : V :: R + r_a : R$

$$\text{or } E = \frac{(R + r_a) V}{R} \text{ and } C = \frac{n Z N}{R + r_a}$$

(2) *Shunt dynamo*.—In dealing with the shunt dynamo we shall find it convenient to use the following additional symbols:—

Let  $c_a$  = the current in the armature.

„  $r_s$  = the resistance of the shunt coils.

„  $c_s$  = the current in the shunt coils.

„  $v$  = the P. D. between the terminals  $b b_1$  (Fig. 484) of the external circuit.

The main current is that of the armature, and it is this that is divided into two parts, hence  $c_a = c + c_s$ .

The joint resistance of external circuit and magnet coils is  $\frac{R r_s}{R + r_s}$ .

Hence the total resistance of the circuit is  $r_a + \frac{R r_s}{R + r_s}$ , and Ohm's law therefore gives us the three following equations:

$$\text{In the whole circuit, } E = \left( r_a + \frac{R r_s}{R + r_s} \right) c_a$$

$$\left. \begin{array}{l} \text{In the outer circuit, } v = C R \\ \text{In the magnet coils, } v = c_s r_s \end{array} \right\} \therefore C + c_s \text{ or } c_a = \frac{v}{R} + \frac{v}{r_s} = \frac{v(r_s + R)}{r_s R}$$

$$\text{Therefore since } E = c_a r_a + v$$

$$E = v \left\{ \frac{r_a}{R} + \frac{r_a}{r_s} + 1 \right\}$$

$$\text{and the "lost" volts } E - v = c_a r_a$$

$$= v \left( \frac{1}{R} + \frac{1}{r_s} \right) r_a$$

**Efficiency of a Series Dynamo.**—From the analogy of the steam-engine, the ratio of the useful energy given out by the machine to the whole electric energy generated is termed the *electric efficiency*. Some of the energy is absorbed in the interior, so that the energy used in the exterior circuit is less than the whole. The energy yielded per second measured in watts is for

the whole circuit  $c$  (amperes)  $\times E$  (volts), and for the exterior circuit  $c$  (amperes)  $\times v$  (volts),

$$\text{Hence the electric efficiency} = \frac{\text{useful power}}{\text{total power}} = \frac{Cv}{CE} = \frac{v}{E} = \frac{R}{R+r}$$

or is equal to the ratio of the external to the total resistance. But the total electric energy developed in the machine, both useful and useless, may not be equal to that taken from the engine or prime mover driving it, hence we must distinguish between

$$\text{the gross efficiency} = \frac{\text{gross electric power generated}}{\text{power received from the driving engine}},$$

$$\text{and the nett efficiency} = \frac{\text{useful electric power delivered}}{\text{power received from the driving engine}}.$$

If the horse-power taken from the engine be  $w$ , or reduced to watts 746  $w$ . we have :—

$$\text{gross efficiency} = \frac{E C}{746 w},$$

$$\text{nett efficiency} = \frac{v C}{746 w}$$

and therefore nett efficiency = gross efficiency  $\times$  electric efficiency. The difference between the power (746  $w$ ) received from the engine and the gross electric power ( $E C$ ) represents the power lost in converting mechanical into electric power.

**Efficiency of a Shunt Dynamo.**—In a shunt dynamo the circuits divide into three distinct parts, and to calculate the efficiency we have :—

I. Work done per second in the outer circuit =  $c v$  or  $C^2 R$ .

II. The power wasted in heating in the shunt =  $c_s v$  or  $C_s^2 r_s$ .

III. The power wasted in heating in the armature =  $C_a^2 r_a$ .

Hence the electric efficiency or

$$\frac{\text{useful power}}{\text{total power}} = \frac{\text{I.}}{\text{I.} + \text{II.} + \text{III.}} = \frac{C^2 R}{C^2 R + C_s^2 r_s + C_a^2 r_a} \dots \dots (I).$$

From the equations  $v = C R$ , and  $v = C_s r_s$  we have  $C_s = \frac{C R}{r_s}$ .

From the equation  $C_a = C + C_s$  we have

$$C_a = C + \frac{C R}{r_s} = \frac{r_s + R}{r_s} C.$$

Substituting the above values for  $C_s$  and  $C_a$  in (I), and dividing numerator and denominator by  $R$ , remarking that then  $C^2$  cancels out, we obtain

$$\text{electric efficiency} = \frac{\text{useful power}}{\text{total electric power}} = \frac{\text{I}}{\text{I} + \frac{R}{r_s} + \frac{r_a (r_s + R)^2}{r_s^2 R}},$$

an expression into which only the resistances of the various parts of the circuits enter.



The total electric power generated is  $E C_a$ , and if  $w$  be the horse-power received from the engine we have as before

$$\text{gross efficiency} = \frac{E C_a}{746 W}$$

$$\text{nett efficiency} = \frac{V C}{746 W}$$

As an example of the use to which these equations may be put we shall calculate the value of the external resistance for which the electric efficiency of a shunt dynamo is a maximum. The problem is in itself an interesting one. We have as above

$$\text{electric efficiency} = \frac{I}{I + \frac{R}{r_s} + \frac{r_a(r_s + R)}{r_s^2 R}}$$

in which  $R$  is variable and  $r_a$  and  $r_s$  are constants.

Now this quantity will be a maximum for that value of  $R$  which will make the denominator the least possible. This denominator may be written thus:

$$I + \frac{R r_s}{r_s^2} + \frac{R r_a}{r_s^2} + \frac{r_a}{R} + 2 \frac{r_a}{r_s};$$

or by writing  $r$  for  $r_a + r_s$ , and adding and subtracting  $\frac{2\sqrt{r r_a}}{r_s}$ , the denominator in question becomes

$$I + 2 \frac{r_a}{r_s} + R \left( \frac{r}{r_s^2} - \frac{2\sqrt{r} \sqrt{r_a}}{r_s R} + \frac{r_a}{R^2} \right) + \frac{2\sqrt{r r_a}}{r_s}.$$

$$\text{or, } I + 2 \frac{r_a}{r_s} + R \left( \frac{\sqrt{r}}{r_s} - \frac{\sqrt{r_a}}{R} \right)^2 + 2 \frac{\sqrt{r r_a}}{r_s}.$$

The part of this expression which changes when  $R$  changes is

$$R \left( \frac{\sqrt{r}}{r_s} - \frac{\sqrt{r_a}}{R} \right)^2.$$

Whatever  $R$  may be, this portion of the expression is positive (for every squared quantity is always positive), and therefore the above denominator is the least possible when this quantity is zero; that is to say, when

$$\frac{\sqrt{r}}{r_s} = \frac{\sqrt{r_a}}{R},$$

$$\text{or } R = r_s \sqrt{\frac{r_a}{r}}.$$

This gives for the maximum efficiency

$$\frac{1}{I + 2 \frac{\sqrt{r_a} (\sqrt{r_a} + \sqrt{r})}{r_s}}.$$

If  $r_a$  be very small compared with  $r_s$ , then  $r$  is but little more than  $r_s$ , and in this particular case the value of  $R$  is nearly equal to the geometrical mean of  $r_s$  and  $r_a$ , for

$$R = r_s \sqrt{\frac{r_a}{r_s}} = \sqrt{r_s r_a},$$

or the external resistance should be a geometrical mean between the armature and the shunt resistance. The result is sometimes useful in determining the best resistance to wind on the shunt coils for specified conditions of working.

**Source of Energy in a Dynamo.**—Before leaving this part of the subject there is one very important matter to which special attention may be called. More than once in the immediately preceding pages it has either been implied or explicitly stated that the electrical energy generated in a dynamo is derived directly from the engine or other prime mover used to drive it. This fact should never be lost sight of, especially by inventors, some of whom fondly imagine that if they can only make an arrangement of magnets and electric circuits sufficiently complicated they may obtain perpetual motion, or, in other words, they may be able to create energy.

The fundamental fact is that whenever a conductor which forms part of a closed circuit moves across the lines of a magnetic field, and has currents thereby induced in the circuit, it experiences a mechanical resistance to its motion, and the latter can only be maintained by the expenditure of mechanical energy. As long as no currents are allowed to flow through the conductors of an

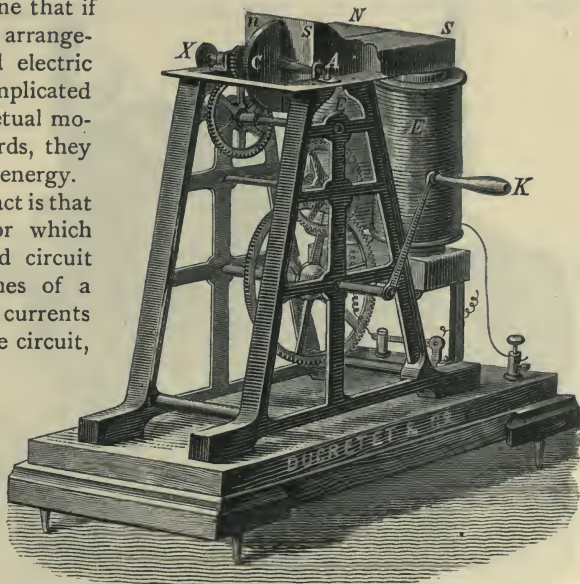

Fig. 491.—Mechanical Energy absorbed by Induced Currents.

armature spinning in a magnetic field it experiences no resistance to its motion other than the mechanical resistances (such as friction of various kinds) which any body of similar shape and mass would experience. The moment currents are allowed to flow everything is changed, and powerful resisting forces are called into play depending on the magnitude of the currents, the magnetic flux, and the velocity; and it is not an uncommon thing to see a dynamo pull up and stop a gas engine or other prime mover many times its size.

An old experiment of Foucault illustrates the above very well. An electro-magnet *E* (Fig. 491) has at its poles *N S* the pole-pieces *n s* so arranged that the copper disc *C*, which can be rapidly rotated about the axis *A X*, can just move between them but not in contact. With the electro-magnet powerfully excited, the resistance to motion is very great.

A striking way to perform the experiment is not to excite the electro-magnet until the disc is rotating at a high speed; on closing the exciting circuit the operator, turning the handle *K*, at once experiences a powerful resistance, against which his speed suddenly falls off.

#### VI.—LATER HISTORY OF CONTINUOUS CURRENT DYNAMOS.

The selection of typical machines bridging the period from the invention of the Gramme and Siemens' armatures to those in use at the present time is not an easy task, for no rigid line of demarcation exists.

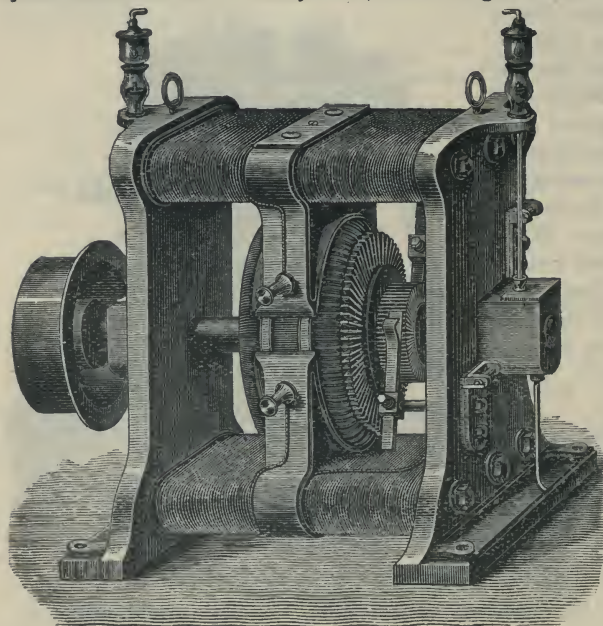

Fig. 492.—Early Gramme Generator.

Some of the machines now in use have remained unchanged in all but very minor details for the greater part of the period, and it is difficult to say whether they should be described here or reserved for the more technical section later on. This is especially the case with machines brought out after the principles of the magnetic circuit had been clearly formulated and adopted by practical men. On the other hand some types have

been frequently modified before settling down to their present form. Further, many of the machines described in the earlier editions of this book have not only become obsolete, but the details of their construction offer no very important points to warrant them being retained even in a historical summary.

With these difficulties to contend with the selection here made must be regarded as tentative and open to criticism, and the inclusion of any particular machine must not be taken as implying that it is now obsolete, or that it might not have been included in the later section. The chief aim is to give the reader, briefly and with the aid of diagrams and descriptions, which might, but cannot, be multiplied indefinitely, some idea of the development of continuous current dynamos.



**Bipolar Dynamos.**—An early form of Gramme machine is shown in Fig. 492. The ring armature (Fig. 464), the electric and magnetic features of which have already been described (*see* p. 486), was mounted on a wooden hub driven by a steel shaft supported by the upright plates, which form the yokes of the double-magnetic circuit of the field-magnet. The latter had "consequent" poles and two projecting pole-pieces, which embraced a very large fraction of the whole periphery of the armature. The field-magnets were in series with the armature, and the terminals were mounted on the side.

One great mechanical defect of this early machine was the arrangement for transmitting the power from the shaft to the wires of the armature through the wooden hub. Later, various methods of "positive" driving were invented, in which either radial spokes or spiders keyed on to the shaft, or some other good mechanical device, was adopted to drive directly the core and the coils wound on it. The magnetic circuit was also deficient in the cross section and quantity of iron used.

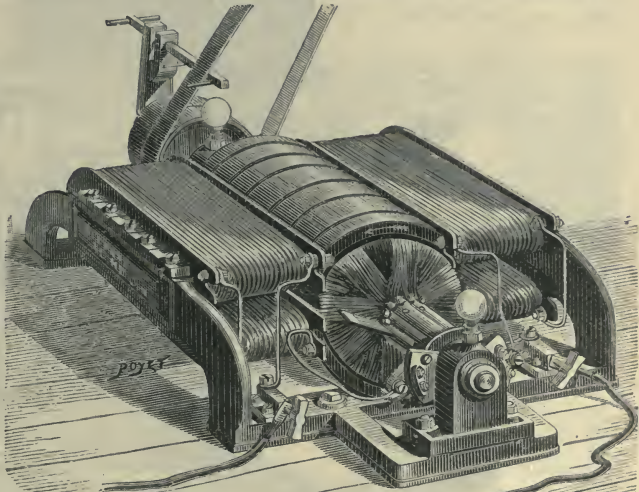

Fig. 493.—Early Siemens' Machine.

The early Siemens' machine had several features in common with the above, though outwardly very different in appearance. The machine is shown in Fig. 493, and we have already had occasion (*see* page 500) to give some details of its magnetic circuit.

There were seven powerful flat electro-magnets on each side, so arranged that their north poles faced one another. The similar poles of the two magnets were connected by arched pole-pieces. The seven iron bands, which were arched round the drum armature, caused two-thirds of the conductors to be exposed to induction at the same time. The current induced in the coils of the armature flowed through the right-hand brush of the current collector, from there into half the coils of the electro-magnet, and then through the right-hand binding screw into the outer circuit, then through the left-hand binding screw into the other half of

the coils of the magnet, and thence back again into the coils of the armature.

Contrast these machines with Crompton's "Trade" dynamo (Fig. 494),

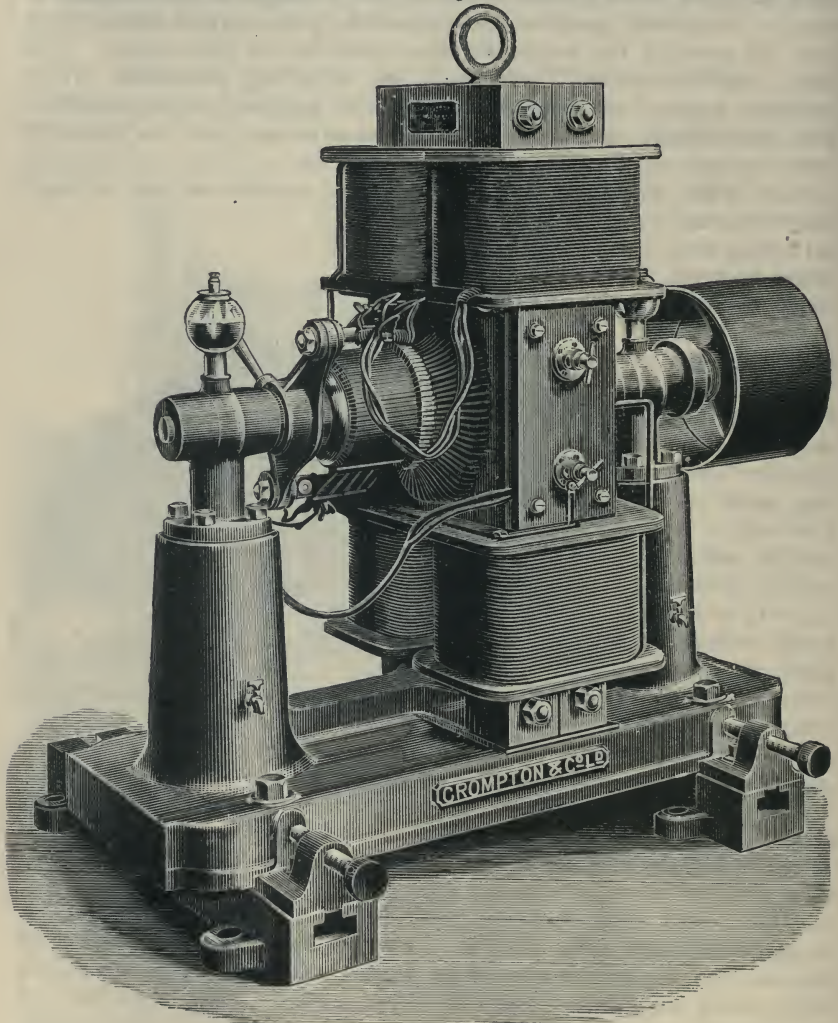

Fig. 494. —Crompton's "Trade" Dynamo.

which was magnetically similar, but, by mechanical modifications which can easily be followed, the magnetic circuit of which was made much more compact, so much so that the outer layers of the magnetising coils



almost touched one another instead of being separated by a wide interval. The yokes and cores were obviously much more massive; they were made throughout of the best annealed wrought iron, and the armature core was built up of laminated iron discs, insulated from each other by a special varnish, the whole being carefully dried in an oven at a high uniform temperature. The armature itself was of the Gramme type, the wires being kept in their places and prevented from slipping by teeth projecting from the circumference of the armature core. The armature shaft was of steel, and an aluminium bronze spider was keyed to it, the arms of which fitted into dovetail notches in the inner circumference of the core discs. It will be noticed that the commutator of this machine was massive, and therefore, as the machine was "non-sparking," should run for years without renewal.

Another machine which was magnetically the descendant of the old Gramme was the "Manchester" dynamo, a part front elevation of which is shown in Fig. 495. Here again the shaft was turned at right angles to the earlier position. In this dynamo

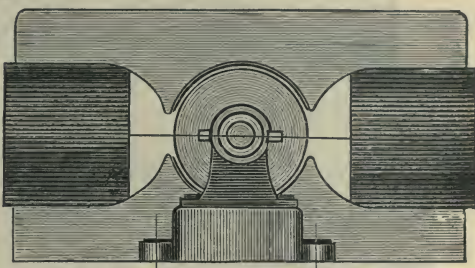

Fig. 495.—The "Manchester" Dynamo" (Elevation).

the exciting coils of the field-magnets were placed on what was the yoke of the old Gramme, with the result that much greater compactness and solidity were given to the magnetic circuit. In the machine as built by Messrs. Mather and Platt (illustrated in perspective in Fig. 496) the armature was of the Gramme type, and was of low resistance and carefully ventilated; it was designed by Dr. John Hopkinson and Dr. Edward Hopkinson. The cylindrical cores of the field-magnets were of wrought-iron, and the yokes, which were very massive, were of cast-iron; there was ample cross-section in all parts of the magnetic circuit, the magnetic reluctance of which, when not fully saturated, was consequently low, but on the other hand the magnetic leakage was somewhat heavy. The commutator was built up of substantial copper bars, 40 in number, which were insulated from one another with mica, and as there was no visible sparking at the brushes, even when the machine was running with a full load, the commutator lasted for years without renewal. One advantage of this type of machine over that last described was that the centre of gravity of the moving parts was low.

*Edison Machines.*—Two-pole machines with a single magnetic circuit, resembling the old horse-shoe pattern of permanent magnet, have played an important part in the development of the modern dynamo. In them the poles may either be at the bottom or at the top, or in an intermediate position. The form with the poles at the bottom, often referred to as



"undertype" machines, was the first to be developed. Wilde's machine (*see* page 476) was magnetically of this pattern, but the first to do any really useful work were the early machines of Edison, one standard pattern of which is illustrated in Fig. 497. Here the field magnets were of great length, in the form of iron bars united by yokes of soft iron, and weighing several tons.

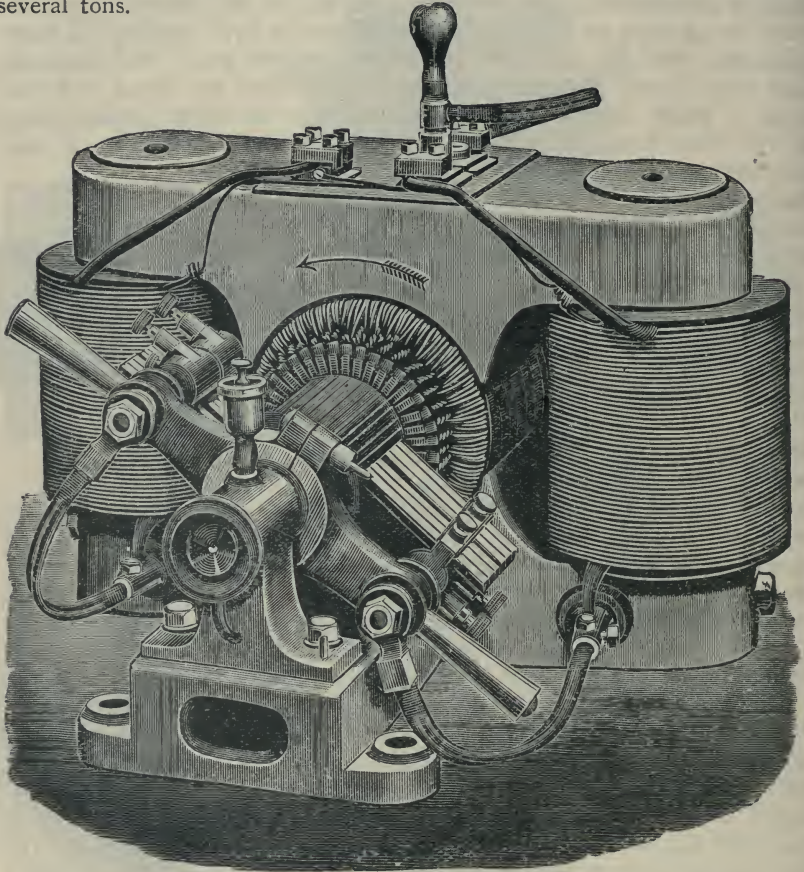

Fig. 496.—The "Manchester" Dynamo.

The steam dynamo, as Edison called a still larger machine, consisted of a horizontal steam-engine of 125 horse-power, and the dynamo-electric machine, which were both fastened upon one platform. The inducing electro-magnets consisted (*see* Fig. 475 c) of eight cylindrical arms, coiled with insulated wire, and two massive cast-iron pieces, which served as poles. The latter were hollowed out so as to provide a space in which the

armature could rotate. The length of the arms of the electro-magnets was nearly 8 feet, and they were placed horizontally. The armature was a drum armature with the conductors consisting of copper strips of trapezoidal cross-section. The different strips were insulated from each other by a kind of blotting paper specially prepared. To the shaft in front of the cylinder were fastened as many copper discs as there were copper strips on the surface; every two diametrically opposite copper strips had their ends connected with a copper disc in such a manner that all the copper strips, discs, and connections formed a continuous coil around the cylinder. By using the copper discs for end connections the resistance of the armature, and especially that of inactive parts near the sides of the cylinder, was reduced to a minimum, and the connection of the several coils was brought about without complicated over-lapping and bunching up of the wire. Such machines were used thirty years ago at the Central Station, New York, to supply a whole district with electricity; and also in London to light the Holborn Viaduct.

The Edison-Hopkinson dynamo was the lineal descendant of the above machines, and Fig. 498 illustrates one built by Messrs. Mather and Platt. The most important improvements made by Dr. J. Hopkinson in 1886 had reference to the magnetic circuit, and greatly modified the external appearance of the machine. Instead of the multiple

field-magnet limbs, each wound with magnetising coils, which join the pole-pieces to the yoke in the older large machines, Dr. Hopkinson used only one limb on each side, solidly connected to the pole-piece at one end and the yoke at the other. The cross-section of the iron cores of these limbs was greater than the cross-section of the iron in the older multiple limbs, and the cores were also shorter in length. In addition the iron yoke across the top was made much heavier. The result of these changes was that the same dead weight of iron was more advantageously arranged for being readily magnetised, because the magnetic circuit was both shortened in length and its cross-sectional area increased throughout. In some of the machines the cross-section of the magnet cores was circular, in others oblong, but rounded at the corners; the latter form allowed relatively longer pole-pieces and armatures to be used. It is shown in Figs. 499 and

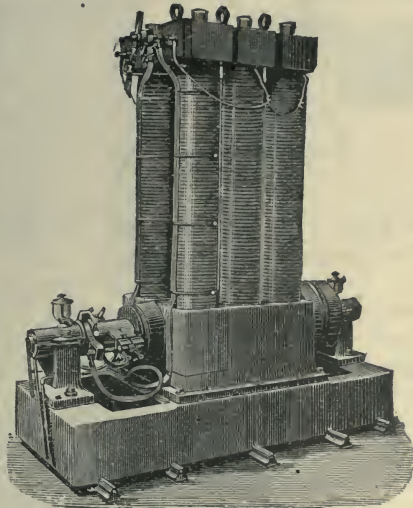

Fig. 497.—Early Edison Machine.



500 which represent a sectional elevation of the field-magnets, and a side elevation of one of the long type machines. The magnet cores and pole-pieces in some of these machines consisted of a single forging, and in more recent machines the magnets were wound with wire of square section,

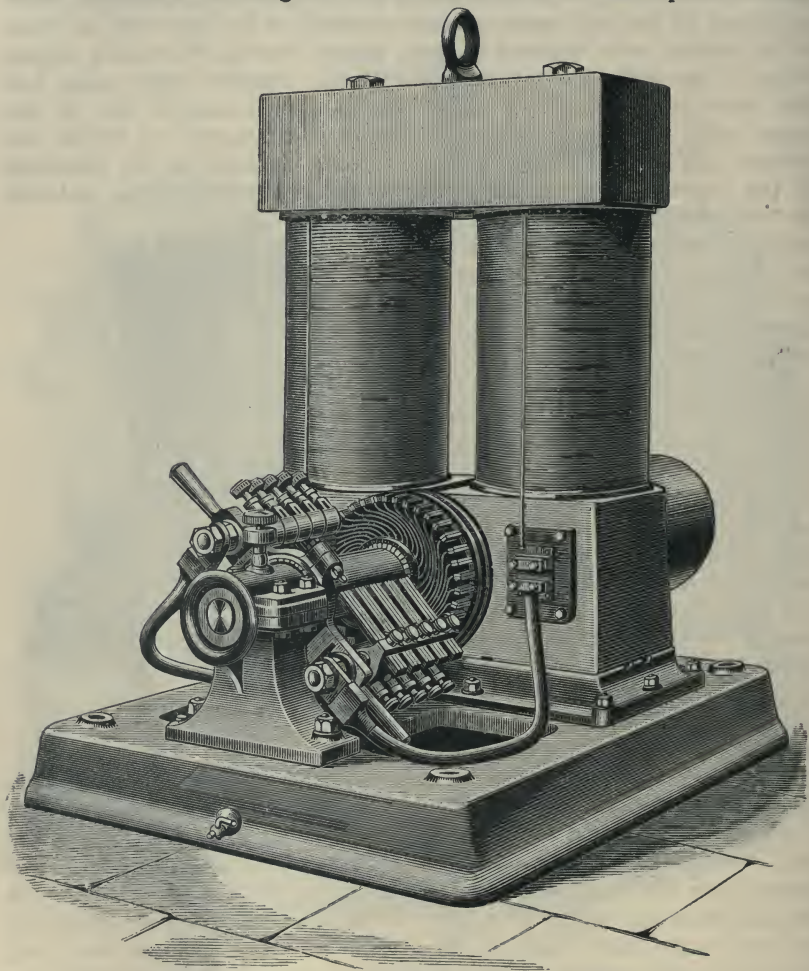

Fig. 493.—The Edison-Hopkinson Dynamo with Bar Armature.

more of which can be packed into a given space than is possible with ordinary round wire. Besides altering the field-magnets Dr. Hopkinson modified the armature of the machine, getting more iron into it, thus diminishing the magnetic reluctance in this important part of the magnetic circuit.



As the result of the modifications it was found that the efficiency of the machine was greatly increased; an early 60-light machine was found to have a commercial efficiency of 58.7 per cent., whereas the more modern machines (of a larger size, however) had a commercial efficiency of 93 or 94 per cent. Also the output was increased; a new 250-light machine only weighing about as much, and occupying the same floor space, as the old 150-light machine. Again, the magnetic field in which the armature moved was

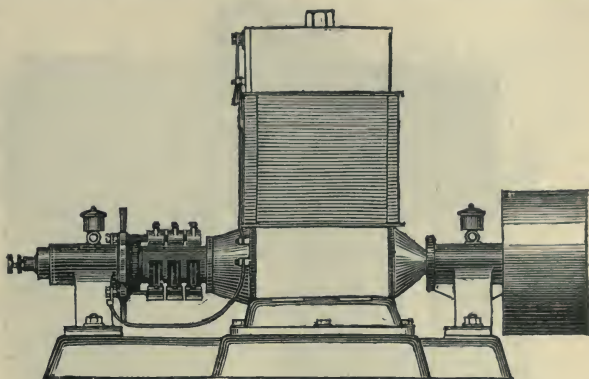

Fig. 499.—Edison-Hopkinson Dynamo (Side Elevation).

so strong, and the resistance of the armature so low, that the "lead" to be given to the brushes was small, and the machine was almost self-regulating without any compound winding on the field-magnets.

The development of the Edison two-pole dynamos in the United States followed very much the same lines as that of the dynamo just described. It is not, therefore, necessary to recapitulate the reason for the various changes from the form depicted in Fig. 497, which may be compared with Fig. 501, representing a machine built by the Edison General Electric Company of New York. The zinc foot-step inserted between the pole-pieces and the bed-plate to diminish magnetic leakage can be clearly seen in this figure and also in Figs. 498 to 500.

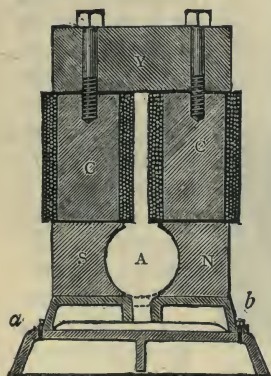

Fig. 500.—Section through Field-Magnet of Edison-Hopkinson Dynamo.

We shall next give one or two examples of the two-pole type in which the poles are at the top of the machine, whence it is known as the "overtype" (*type supérieur*). Such a machine, as far as the field-magnets are concerned, can be described as an Edison-Hopkinson dynamo turned upside down, the yoke of the latter becoming the bed-plate of the new machine, and the armature being raised to the top. The armature, however, may be of the ring or of the drum type, with or without projecting teeth. Magnetically the advantage of this design is that where the lines of force leave the N pole-

piece to pass through the armature to the s pole-piece there is no large mass of iron in the neighbourhood to deflect them from their course by its high permeability. On the other hand, in machines built like the Edison-

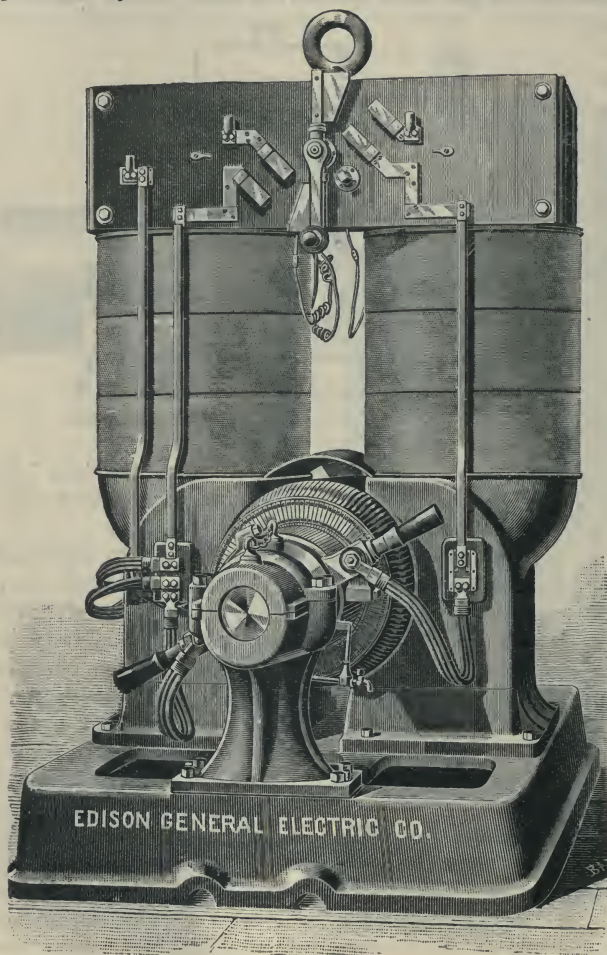

Fig. 501.—Modern Edison Two-pole Dynamo.

Hopkinson, there must necessarily be in the neighbourhood of the pole-pieces the large iron mass of the bed-plate, with its tendency to cause the lines of force to run from one pole-piece to the other through it instead of through the armature. Such leakage lines are, of course, lost to the machine for the purpose of setting up E. M. F. in the wires of the armature, since they are not cut by those wires, and therefore the energy spent to maintain them is wasted. The difficulty is partly met by interposing a zinc base between the pole-pieces and the iron bed-plate.

In Fig. 500 this base (*a b*) is shown in section, and in that dynamo it separates the bottom of the pole-piece from the top of the iron by a distance of five inches.

Mechanically the great disadvantage of the oertype machines is that the bearings have to be elevated with the armature, and this necessarily increases the cost of construction; but as the builder aims at making



his magnet-limbs, for magnetic reasons, as short as possible, magnetic and mechanical considerations both combine to bring down these elevated bearings to a manageable height.

*The "Phoenix" Dynamo.*—This name was given by Messrs. Paterson and Cooper to the various types of dynamos built by them, some with single, others with double magnets, but their standard machine in 1887 was of the single-magnet type to which we have just been referring. It is illustrated in

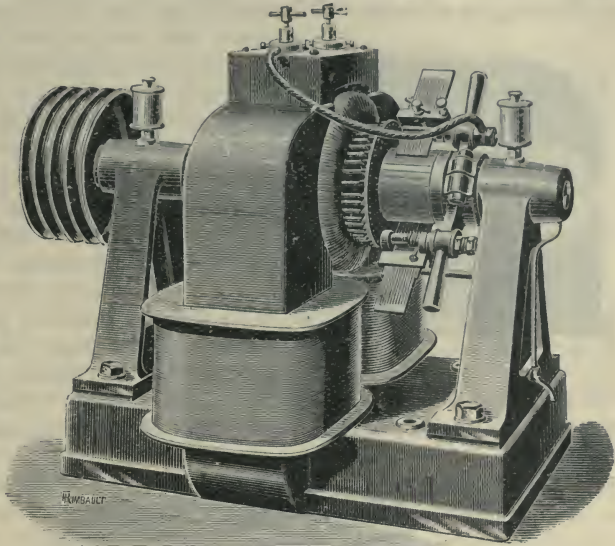

Fig. 502.—The "Phoenix" Dynamo.

Figs. 502 and 503; the first figure shows the complete machine in perspective and the second figure gives a section through what may be termed the iron carcass of the machine with the armature core in its place.

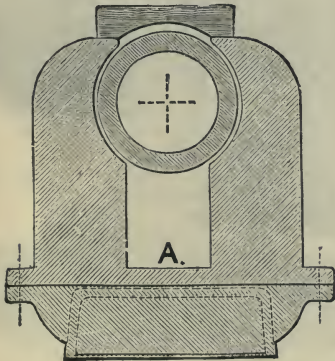

Fig. 503.—Section through Field-magnets of Phoenix Dynamo.

The horse-shoe magnet limbs and thin connection A (Fig. 503) were cast in one piece as shown, and bolted to the thickened solid bed-plate, which thus formed the greater part of the yoke of the horse-shoe, and provided ample cross-section of iron for the magnetic lines. In some of the machines the iron of the magnet consisted of a solid wrought-iron horse-shoe forging, machined all over, and bored out for the armature. The magnet coils were wound on separate bobbins of sheet-iron flanged with brass, and after being wound, were slipped over the tops of their respective limbs into place. The armature was of the Gramme ring cylindrical type, and was supported by cast-iron brackets bolted to the



bed-plate, the bearings being of white metal. The machines were built of various sizes, with outputs varying from 600 to 50,000 watts.

Turning now to the third possible position for the pole-pieces, a very compact and convenient form of two-pole single magnetic circuit, especially for machines of moderate dimensions, is shown in Fig. 504. This pattern of dynamo machine was independently designed by Dr. S. P. Thompson and more than one firm of dynamo builders in 1886. From the shape of the magnetic circuit it is sometimes referred to as the C-type of dynamo machine. The ample cross section of the iron in all parts of the circuit is obvious, and the different parts of the field-magnet are of a shape easily manufactured. Moreover, there is only one magnetising coil,

which can readily be wound and slipped into its place. Here, again, however, owing to the position of the magnetising coil, the magnetic leakage is considerable.

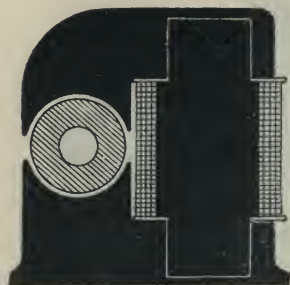

Fig. 504.—C-type of Magnetic Circuit.

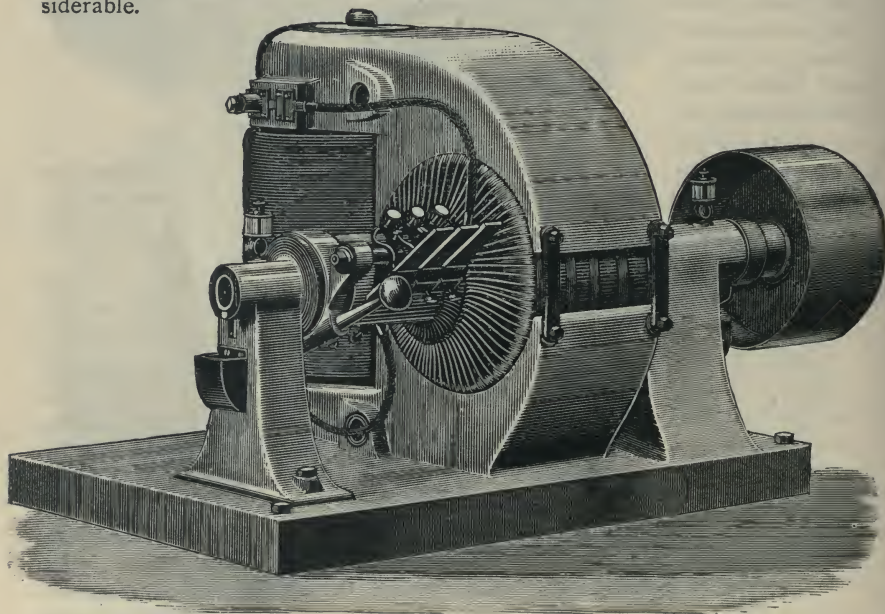

Fig. 505.—The "Leeds" Dynamo.

An actual machine of this type is represented in Fig. 505. This particular dynamo, known as the "Leeds" dynamo, had a magnetic circuit

different only slightly in details from Fig. 504. The upper and lower polar limbs were of annealed cast iron, and it will be noticed that the lower one was cast in one piece with the bed-plate, part of which was thus introduced into the magnetic circuit; the core upon which the magnetising coil was slipped was of soft wrought-iron of high permeability. The armature was of the Gramme or ring type, and in the larger machines consisted of a single layer of copper strip. In a 35 kilowatt machine which gave 70 amperes at 500 volts, with a speed of 800 revolutions per minute, the outside diameter of the armature was 18.5 inches, and its length 14 inches, and there were 80 bars on the commutator. Some of these machines were used in the Cadogan Lighting Station at Chelsea.

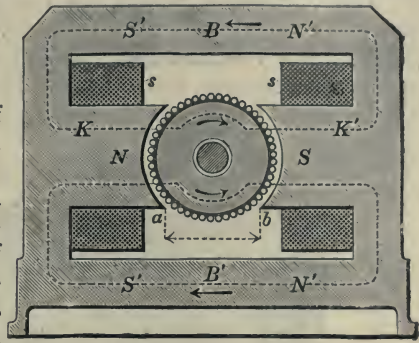

Fig. 506.—Magnetic Circuits of Iron-clad Dynamos.

**Iron-clad Dynamos.**—Another type of dynamo which was developed by more than one good firm of builders is known as the *iron-clad* type, from the fact that the magnetising coils of the field-magnets are almost hidden from view by other parts of the magnetic circuit. This circuit, as adopted in several examples, is shown diagrammatically in Fig. 506. It will be noticed that it is a double magnetic circuit, but that the poles are "salient," and not "consequent" poles, each magnetising coil embracing all the lines of force of the circuit. The path of one of these lines of force in each of the two halves of the circuit is shown by the two continuous dotted lines in the figure.

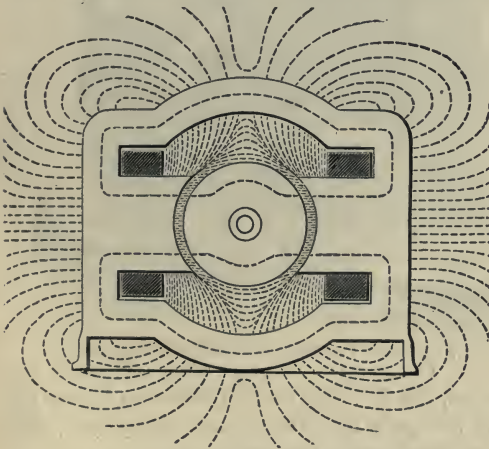

Fig. 507.—Leakage Field of Iron-clad Dynamo.

A disadvantage of this form of magnetic circuit is that there is a tendency for lines to leak from the projecting parts of the pole-pieces, especially at the tips, to the iron of the surrounding yokes. In some patterns, therefore, the enclosing iron is arched as it passes over or under the armature so as to increase the air



space, as shown in Fig. 57. In this figure the paths of the leakage lines are drawn; an inspection of these will be instructive, as showing the distorting influences affecting the passage of useful lines through the armature.

**The Victoria Dynamo.**—A machine which cannot be passed over in any history of dynamo development at this period is the Victoria dynamo of the Brush Electrical Engineering Company. The machine was originally a Schuckert dynamo, and as such will be found described in a former edition of this book, but it was improved and modified, both electrically and mag-

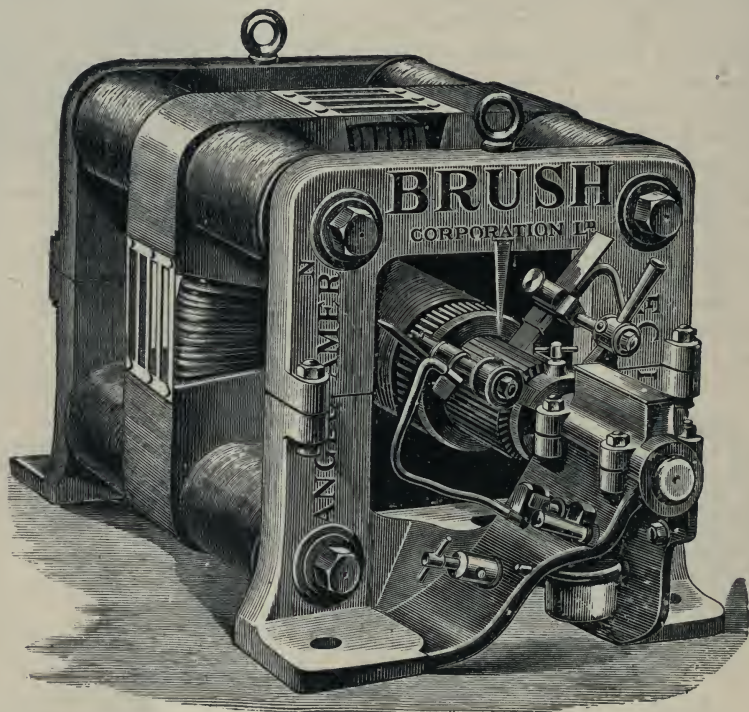

Fig. 508.—Victoria (Schuckert-Mordey) Dynamo of the Brush Electrical Engineering Co.

netically, almost past recognition, by Mr. Mordey. Under his hands the two-pole Schuckert became the four-pole machine shown in Fig. 508, with good magnetic circuits and a well-designed armature.

As regards the magnetic circuit, the pole-pieces were made of cast-iron shrunk upon the cylindrical cores of soft iron which received the coils, and the whole magnetic circuit was of ample cross-section. The armature had a core made almost of square section, and built up of charcoal iron tape, coiled upon a strong foundation ring, with paper



between successive layers to prevent contact and the formation of eddy currents. The foundation ring and some of the inner convolutions of tape were slotted out to receive the gun-metal driving arms, of which there were two sets clamped together, one on either side. Fig. 509 shows some of the details, and the position of the coils. Square wire was used, and as the coils did not cover the entire external surface of the armature core there was ample ventilation. The figure also shows how the pole-pieces embrace the full depth of the ring, and thus reduce the reluctance of the gap between the iron of the pole-pieces and the iron of the armature. End play of the driving shaft was prevented by a deeply-grooved Babbitt-metal thrust-bearing at one end.

Since the machine had four poles, alternately north and south, every armature coil, during a single revolution, twice embraced a maximum number of positive lines of force, and thus there were two points of maximum and two points of minimum potential on the collector. In the earlier machines there were four distinct brushes fixed at  $90^\circ$  angular distance from one another round the commutator at the above four points, providing, there-

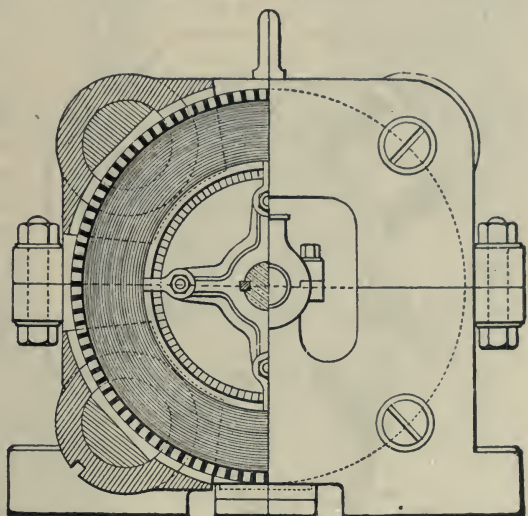

Fig. 509.—Victoria Dynamo (End View and Transverse Section).

fore, either two separate circuits, or, by being joined together in parallel, throwing the whole current of the machine into a single circuit. But by internal cross connection this number was reduced to two, fixed  $90^\circ$  apart.

**Multipolar Dynamos.**—Several reasons—mechanical, electrical, and magnetic—induced builders of large continuous current dynamos to develop a class of machines in which the field-magnets have more than two poles. The mechanical and other advantages of coupling the dynamo directly to the shaft of the engine pointed to the necessity of designing a dynamo that would generate the necessary electromotive force at a much lower speed than was at first thought to be possible; for the slowest-running dynamo of early days, with its speed of 700 or 800 revolutions per minute, could not possibly be so coupled to the quickest speed-reciprocating steam-engine then available. Engine-builders, on their side, endeavoured to meet the difficulty

by designing high-speed engines; but their limits were then lower than the speed just mentioned, and had not electricians reduced their demands in this respect direct coupling would have remained for some time impossible for continuous current machines.

The E. M. F. developed by a dynamo depends on the speed with which the conductors of the armature cut across the magnetic field produced by the field-magnets, and one way of maintaining a given speed of the conductors, whilst diminishing the number of revolutions of the armature per minute, is to build armatures of large diameter. But two-pole machines become very cumbrous and unwieldy if this plan is pushed very far.

If instead of two poles we surround the armature with four, and cause

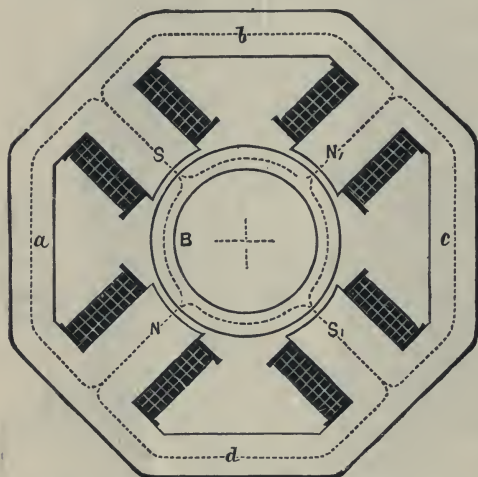

Fig. 510.—Magnetic Circuits of a Four-pole Dynamo.

the same flux of magnetic lines to pass through each as when we had only two, then for the same armature we could with one-half the speed obtain the same E. M. F. As a matter of fact, the gain in practice cannot be so great, because the surface of each pole cannot be as large as in the two-pole case, and therefore the magnetic flux must be less. But by increasing the diameter of the armature we get increased room for polar surface, and at the same time increase the circumferential speed for a given number of revolutions per minute. Both these changes tend to bring about the desired result. The general arrangement of the magnetic circuit of such a four-pole machine is depicted diagrammatically in Fig. 510. The exciting coils of the field-magnet are wound upon the four poles  $N, S, N_1, S_1$ , which are directed inwards from a heavy yoke,  $a b c d$ , which forms the outer frame of the machine. These poles are, of course, alternately north and south. The iron of the armature is represented by  $B$ , and the course of the magnetic flux is shown by dotted lines. It will be noticed that on leaving the cores, either for the armature or yoke, the lines from any pole divide into two bundles, which pursue different paths to the right and left.

The actual machine whose magnetic circuit is represented in Fig. 510 was a dynamo built by the Oerlikon Maschinenfabrik of Zurich, and had an output of 300 amperes at 600 volts, or 240 electrical horse-power, and therefore nearly double that of the early steam-dynamos. The field-

magnets were of cast-iron, and because of the lower permeability had to be more massive than if they were of wrought-iron or mild steel. The lower part formed a single casting with the bed-plate and supports for the bearings, and the upper part was bolted to it. The armature was of the then large diameter of 37 inches, and had a central hole 23 inches in diameter, which secured good ventilation, keeping the conductors cool at full load; its length was 22 inches, and it was driven by a spider keyed to the shaft, and having eight arms which fitted into notches in the iron of the core. This core consisted of wrought-iron flat rings or washers  $\cdot 024$  inch in thickness. The Gramme ring method of winding was used, the conductor being a 19-strand cable making 400 convolutions, every second one of which was connected to the commutator. An inspection of Fig. 510 will show that there must be four *neutral* points round this armature, and in this machine four

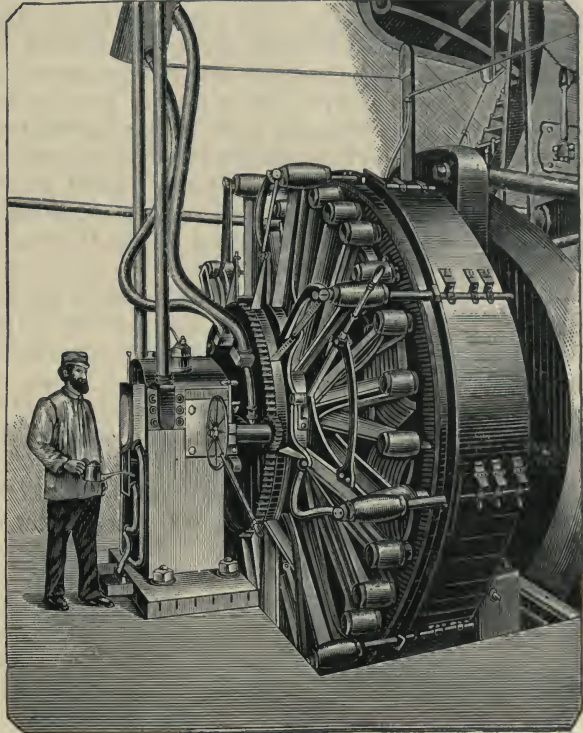

Fig. 511.—Siemens and Halske's Internal Pole Dynamo.

sets of brushes were used, connected two and two in parallel. The speed required for the above output was 480 revolutions per minute.

The multipolar dynamo shown in Fig. 511 is one which was exhibited by Messrs. Siemens and Halske at the Frankfort Exhibition of 1891. It is interesting in two ways; firstly, because the rotating armature was placed *outside* the fixed field-magnets, and, secondly, because the commutator as a separate part of the machine was dispensed with, the collecting brushes simply resting upon the outer wires of the armature whose external surfaces are left bare for the purpose.



The machine had a field-magnet with ten poles directed radially outwards from a solid, heavy, central yoke ring, the diameter from the face of one pole to the face of the opposite one being 8 feet 11 inches. Each core carried one magnetising coil about 14 inches long, which was traversed by a shunt current. The armature, which is obviously of the ring type, was 9 feet 10 inches in external diameter, and consisted of 810 external and 810 internal copper bars, united by end connections so as to form a continuous spiral closed on itself. The external conductors were 0.4 inch wide, insulated from one another by compressed paper, and, as already explained, form the commutator of the machine. The spider arms, which drive the armature, were mounted directly on the shaft of the driving engine, without any coupling between the dynamo and the engine. There were altogether ten sets of brushes alternately connected together so as to form two parallel groups of five each. All these sets could be simultaneously shifted round by means of the wheel gearing seen at the side, and could be lifted out of contact altogether by moving the hand-lever.

The normal speed of the machine was 80 revolutions per minute, at which it gave a current of 2,000 amperes with a pressure of 150 volts; its output was therefore 300 kilowatts or 400 electrical horse-power. It had, however, been run at 100 revolutions, at which the potential difference rose to 200 volts, and as the armature could carry 3,000 amperes without undue heating the full capacity of the machine may be taken to be 600 kilowatts or 800 electrical horse-power.

We do not propose to carry the history of continuous current dynamos any farther just now, but shall reserve such other historical comments as may be necessary for the technological section.

## CHAPTER XIV.

## ALTERNATE CURRENTS AND ALTERNATORS.

## I.—ALTERNATE ELECTRIC CURRENTS.

THE electric currents considered in the foregoing pages are, for the most part, such as flow steadily for an appreciable time in one direction in the conductor or conductors of the circuit, being maintained therein by a steady electro-motive force or potential difference. In other words, they are *unidirectional* currents. It is true that the E. M. F.'s generated in the armature of a continuous-current dynamo are being continually reversed in direction *in the conductors* of the armature, but, by means of the commutator, the consequent P. D.'s in the outer circuit are all brought into the same direction, and steady *direct* or *continuous* currents, as they are called, flow in that circuit. Even

in the armature, if we do not consider what happens in the individual conductors, the currents generated are always in the same direction *in space*. That is, viewed from any fixed position outside the rotating armature, the currents would

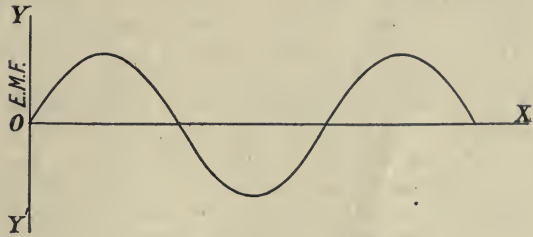

Fig. 512.—Diagram of e.m.f.'s in a Single Loop.

always appear to be flowing in the same direction. If, however, the commutator be suppressed, and the armature and the outer circuit be put in series by means of sliding contacts, such as we see in Fig. 457, then the changing E. M. F.'s in the conductors of the armatures must produce currents with similar changes in the outer circuit.

For instance, the varying values of the E. M. F. may be represented by some such curve as that shown in Fig. 512, where the values of the E. M. F., at successive instants of time, are plotted vertically, the time itself being measured along the horizontal line  $ox$ . Positive values of the E. M. F. are marked off above the line  $ox$ , and negative ones below that line, the vertical scale in both cases being the same. The result is the curve, of which three loops are shown, two positive

and one negative. These loops are supposed to be preceded and followed by a great number of precisely similar loops, the condition being that the  $+$  and  $-$  loops are to *alternate* as we move from left to right along the time line  $ox$ .

Now such an impressed E. M. F. must obviously give rise in a simple circuit (*i.e.* with no commutator inserted) to a current which, if similarly plotted, would show  $+$  and  $-$  loops following one another with the same frequency as the loops of E. M. F. For it is manifest that the current cannot always be in one direction when the E. M. F. is changing in direction, as shown in Fig. 512. On the contrary, it must follow these changes more or less promptly, but so that, on the whole, in a given interval of time the current changes in direction as frequently as the E. M. F. For reasons, however, that will presently be set forth, the *shape* of the current curve may be very different from that of the E. M. F. curve, though it must consist of the same number of loops per second.

Such a current is known as an alternating or, more shortly, an *alternate* current. Most usually the changes in the magnitude and direction of the current follow one another in a definite cyclic order, a complete cycle embracing all the changes from the instant when the current has a certain value in one direction until it again has the corresponding value in the same direction. When such cycles are repeated over and over again in precisely the same manner for a very great number of times a kind of steady condition of things is set up, and the current in a certain sense may be said to be steady. The changes then are described as both *cyclic* and *periodic*.

If successive cycles are not exactly similar in all details, then the changes, though cyclic, are not periodic. Thus the successive beats of a pendulum are both cyclic and periodic, but the motion of a train on the Inner Circle Railway of London, though cyclic, is not periodic, because the minor details of the motion differ in successive cycles.

Other quantities besides E. M. F. and current may pass through cyclic and periodic changes, and in all cases the time ( $\tau$ ) occupied in making a complete cycle is known as the *period* or as the *periodic time* of the cycle. It is usually measured in seconds or fractions of a second, and then the number ( $n$ ) of cycles per second is called the *frequency*. These two quantities are obviously connected by the equation

$$n\tau = 1$$

For example, if a cycle have a periodic time of  $\frac{1}{100}$ th of a second, the frequency will be 100 per second. In power transmission and electric lighting the frequencies vary from 25 to 120 per second, but in experimental work they may be as high as thousands or even millions per second.

**Pulsating Currents.**—Besides alternate currents we may sometimes



have currents whose values pass through cyclic and periodic changes, but the currents themselves are always in the same direction. Such currents fluctuate between maximum and minimum values, but the latter never fall so low as to cause a reversal in direction. Such a current would be that depicted graphically in Fig. 513, which is drawn in the same manner as Fig. 512. We have an analogy to these currents in the flow of blood through the body as controlled by the beat of the heart. The flow is sometimes more rapid, sometimes more sluggish than the average, but it is always in the same direction, and passes through series after series of cyclic and periodic changes. In accordance with this analogy the electric currents referred to are known as *pulsating* currents.

**Importance of the surrounding Medium.**—Whether, however, the currents be true alternate currents or simply pulsating currents, whether they be truly periodic or not, or even whether they be strictly cyclic or not, the point in which they differ from the currents previously considered is that they are subject to rapid and recurring changes in value. These changes in the value of the current lead to corresponding changes

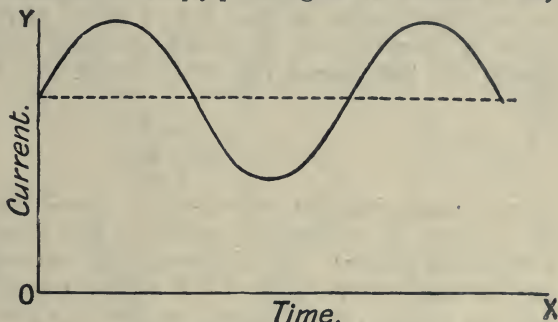

Fig. 513.—Diagram of a Pulsating Current.

in the amount of energy stored in the surrounding medium, and it is the necessity for taking account of these energy changes in some form or other that constitutes the additional factor to be considered. We have seen that the energy stored in the medium may be electro-magnetic or electrostatic, or both. As a matter of fact, it is both in all cases. But in many practical cases the electro-magnetic store of energy is so many times greater than the electrostatic store that the latter may be disregarded in comparison with the former. It is only when the electrostatic capacity of the oppositely charged conductors is large that it must be taken into account, and such cases are not infrequent under certain engineering conditions.

## II.—ELEMENTARY LAWS OF SIMPLE ALTERNATE CURRENTS.

As regards the electro-magnetic energy stored in the medium, we have already seen (page 423 *et seq.*) that the changes occurring in it make themselves felt in the circuit by means of the E. M. F.'s of **self-induction**, and that these E. M. F.'s are directed so as to oppose the magnetising

current when the magnetic field is increasing, and to assist the current when the field is diminishing. Therefore, in applying Ohm's law to this case we must take account of these E. M. F.'s as well as of those of the battery or electric generator which is our primary source of electric pressure. It is sometimes said that Ohm's law does not apply to alternate current circuits. The statement, however, is inaccurate, for if all the circumstances are taken into account Ohm's law is strictly applicable, but it cannot be expected to lead to accurate results if some of the electric pressures in the circuit are neglected.

**Inductance.**—To obtain a general idea of the effect of the additional factor we must remember that the E. M. F. of self-induction is measured by the *rate of change* of the *magnetic lines of force enclosed by the circuit*. If we consider the individual conductors, the E. M. F. is measured by the *rate* at which *the magnetic lines cut the conductor considered*. The ratio of the total number of lines  $N$  in a circuit to the current  $c$  producing them is often referred to as the *co-efficient of self-induction*, or more shortly the **inductance** ( $L$ ) of the circuit. Thus we have

$$\frac{N}{C} = L$$

$$N = LC$$

If we assume that the inductance, as above defined, is independent of the current, an assumption which is not true when iron forms any considerable portion of the surrounding medium, then  $N$  and  $c$  will vary proportionally. Thus if  $dc$  denote a small increase in  $c$  (which becomes  $c + dc$ ) and  $dN$  the corresponding small increase in  $N$  (which therefore becomes  $N + dN$ ), we have

$$N + dN = L (c + dc),$$

and therefore

$$dN = L dc$$

If these changes occur in the short time  $dt$ , then the *rate of change* in  $N$  is given by the equation

$$\frac{dN}{dt} = L \frac{dc}{dt}$$

the right-hand side of which expresses the magnitude of the back E. M. F. of self-induction in terms of the inductance and the rate of change of the current. When the current is increasing the E. M. F. of the generator has to balance this back E. M. F. as well as to provide the P. D. necessary to send the current  $c$  through the resistance  $R$ . Ohm's law equation, as given on page 182; therefore becomes for this case

$$RC = E - L \frac{dc}{dt} * \dots \dots \dots (1)$$

$$\text{or } RC + L \frac{dc}{dt} = E \dots \dots \dots (2)$$

\* The minus sign is required by Lenz law, since an increase in  $c$  gives a back (or —) E. M. F.

where  $\mathcal{E}$  is the E. M. F. of the generator. This equation, which is the fundamental equation when the current is changing, unfortunately contains the infinitely small quantities  $d c$  and  $d t$ , as well as the varying quantity  $\mathcal{E}$ . The form of its solution in finite terms depends upon the form of the variation of  $\mathcal{E}$ , which is sometimes very complex.

**Sine Curves.**—But if  $\mathcal{E}$  or  $c$  be a cyclic and periodic function, Fourier long ago showed that either can be expressed algebraically as a sum of trigonometrical sines and cosines, in which the time  $t$  is the variable, and appropriate constants are introduced to adjust the actual magnitudes. Thus in the diagrams of Fig. 514, which are drawn according to the same conventions as Fig. 512, the curves drawn with thick lines can be resolved into the simpler curves A and B shown by the dotted lines.

In (a) the component curves A and B have periodicities in the ratio of three to one; that is, curve B has three times as many periods per second as curve A. All the curves, however, cross the zero line

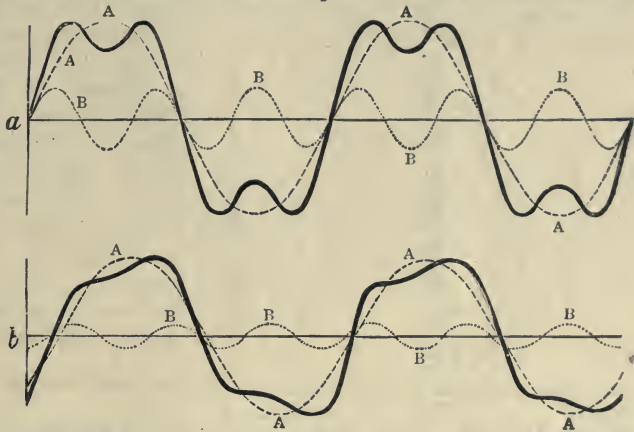

Fig. 514.—Resolution of Complex Cyclic Periodic Curves into "Sine Law" Curves.

at the same time, and the resultant curve, though curiously unlike either of them, has a certain symmetry. In (b) the component curves, besides having periods in the ratio of three to one, cross the zero line at different points. The resultant curve produced is still less similar to its components, and is curiously and unsymmetrically humped. At first sight it is difficult to believe that such a curious curve could be resolved into two such simple and symmetrical ones.

In both figures the component curves are sine curves, and as the curves for sine and cosine functions are exactly similar in form, the simplest supposition that can be made for the variation of  $\mathcal{E}$  or of  $c$  is that it follows a *sine law*. The curve in Fig. 515 shows graphically such a function for one complete cycle. In it time is plotted horizontally, and the E. M. F. or the current plotted vertically upwards (+) and downwards (−) from the centre line, which is also the zero line. The figures along o T are fractions of the periodic time, which is represented by



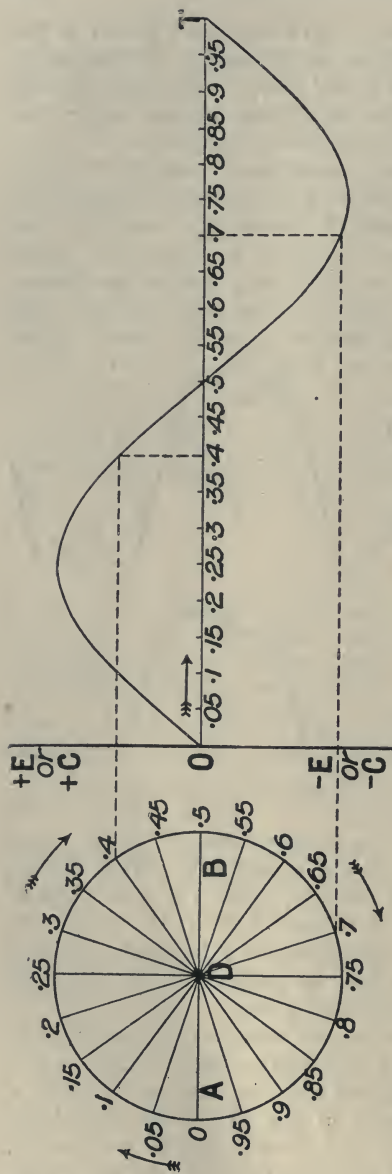

Fig. 515.—Simple construction for a "Sine" Curve.

o T, the corresponding values of the function being obtained in the way shown by projection from the circle, the circumference of which has been divided into the same number of fractional parts as o T. The radius DO is to be regarded as revolving round D in a clockwise direction, so as to make a complete revolution in the time T. At each instant the distance of o above or below the datum line ADB will give the corresponding ordinate or vertical height on the sine curve.

**Effects of Inductance in Simple Cases.**—To examine the effects of inductance when the current follows this simple law,

plot, by the above or any other method, a sine curve x H H' H, etc. (Fig. 516), to represent the current c. To obtain from this the E. M. F. of self-induction, we observe that the slope of H H' H

measures the rate of change  $\frac{dc}{dt}$  of the current, and, therefore, to a proper scale the E. M. F. of self-induction  $(L \frac{dc}{dt})$ . The slope

is steepest where the curve crosses the zero line, and here we have the maximum values (either — or +) e, e', e, etc., of the induced E. M. F. The slope is zero at the points H, H', H, etc., and therefore here we have the points j, m, etc., where the induced E. M. F. is zero. Remembering that the curve must be negative whilst the current is continually increasing

between H and H', other points can easily be obtained, and we get the dotted curve j e e' m e' e to give the values of the self-induction or inductive E. M. F.

$$L \frac{d c}{d t}$$

Now the curve  $HN'H$  can also be taken to represent the *acting or effective E. M. F.* ( $Rc$ ) which sends the current  $c$  through the resistance  $R$ , for the two quantities  $c$  and  $Rc$  must alternate together, and it is only a question of adjusting the scale of the amperes and the volts to make the same curve represent both.

This effective E. M. F. is the algebraical sum of all the actual E. M. F.'s in the circuit, which consist of the E. M. F.'s due to inductance and the E. M. F. of the generator, or, as we may call it, the *impressed E. M. F.* The last-named E. M. F. is, therefore, equal to the difference between the effective and the inductive E. M. F.'s, and we can, therefore, obtain the shape of the necessary curve by *subtracting* the curve  $e'e'e$  from the curve  $HN'H$ . This is readily done by taking a sufficient

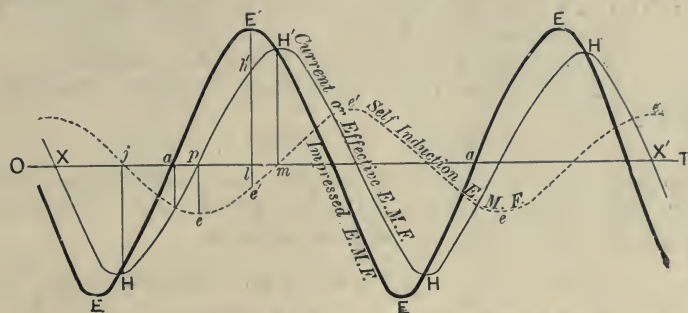

Fig. 516.—Effects of Inductance in an Alternate Current Circuit.

number of points along  $OT$ , and for each point algebraically subtracting the ordinate (as the vertical distance is called) of the first-named curve from the ordinate of the second, and marking off the result as a new ordinate. When the ordinates are on opposite sides of  $OT$  they are to be added, and the point marked off on the  $HN'H$  side; when they are on the same side the difference is to be taken and plotted on the  $HN'H$  side, if that ordinate be the greater, and on the opposite side if it be the lesser of the two ordinates. The result is the curve  $E'E'E$ .

*Phase and phase-difference.*—In the figure now completed the three curves do not reach their positive maxima at the same time; in other words, they are not in the same *phase*. The fraction of the full periodic time at which currents of the same period successively reach their positive maxima expresses the *difference of phase* between them. Thus, if the period be  $\frac{1}{100}$ th of a second, and one current reaches its positive maximum  $\frac{1}{300}$ th of a second after another, its phase is said to be one-third of a period behind the first. By the *phase* of the currents being opposite we mean that one reaches its *negative* maximum at the same time that the other reaches its

positive maximum. Any other salient position may be used for comparing phases, e.g. the moment of crossing the zero line on the upward swing. For instance, the curve  $e' e' e$  lags a quarter period behind the curve  $h h' h$ ; that is, it arrives at its positive maximum  $e'$  exactly a quarter period later than  $h h' h$ . Again, the curve  $h h' h$  lags behind the curve  $e e' e$  by whatever fraction of a period is represented by  $a p$ .

Again, if  $e e' e$  represent the impressed E. M. F., then, with the scales used, the same curve would have represented the current had there been no inductance. But it will be noticed that the maximum values of the actual current curve  $h h' h$  are less than those of the curve  $e e' e$ . This is technically expressed by saying that the *amplitude* of the curve  $h h' h$  is less than the amplitude of the curve  $e e' e$ .

Thus the diagram shows that the effects of inductance are twofold, namely:—

(i.)—To cause the current curve to lag behind the curve for the impressed E. M. F., and

(ii.)—To diminish the amplitude of the current curve.

To arrive at the same result algebraically we must write for the impressed E. M. F.

$$E = E_0 \sin pt. \quad \text{Where } p = 2\pi n, *$$

$n$  is the *periodicity* or number of complete *periods per second*, and  $E_0$  represents the maximum voltage at the top of the curve. The equation (2) (see page 538) to be solved, therefore, becomes

$$RC + L \frac{dC}{dt} = E_0 \sin pt. \quad \dots \quad \dots \quad (3)$$

Now the current  $C$  must have the same periodicity as  $E$ , but may differ in phase from it. It must also follow a sine law. Further, we have seen that the quantity  $L \frac{dC}{dt}$  lags  $90^\circ$  in phase behind  $C$ , and it can be shown that its numerical value at any instant is  $pLC$ , the value of  $C$  taken being  $90^\circ$  earlier. To combine  $RC$  with this, and also allow for the phase difference, recourse must be had to the method of Fig. 515, where the successive values of the sine function are given by the position of one end of a line revolving round its other end, as already explained.

A diagram in which only the circular part of Fig. 515 is used is known as a *clock-diagram*; it is convenient when several sine curves have to be dealt with simultaneously, each curve being represented by the *revolving radius* from which it can be derived by projection according to the method of Fig. 515. In such a diagram let  $DA$  (Fig. 517) represent at some instant of time the position and length  $RC_0$ † of the line, which, by revolving

\* This value of  $p$  is taken so that  $E$  may vanish once in every half revolution, or whenever  $t$  is equal to any multiple of  $\frac{T}{2}$ . It is really the *angular velocity* of  $DO$  (Fig. 515).

† In what follows the expressions  $E_0$ ,  $C_0$ , etc., denote the *maximum* values of the quantities referred to.



round D, will give (as in Fig. 515) the curve for R C, the effective E. M. F. Then a line D B equal to  $\rho L C_0$  and following D B at an angular distance A D B of  $90^\circ$  will, in the same way, give the curve for the inductive E. M. F. Now, D A is the resultant or vector sum of the impressed E. M. F. and the inductive E. M. F., and is, therefore, the diagonal of a parallelogram of which the other two form the sides. Complete this parallelogram D M A B by drawing the dotted lines as in the figure, and D M will be the position and magnitude of the impressed E. M. F. at the instant considered. This shows

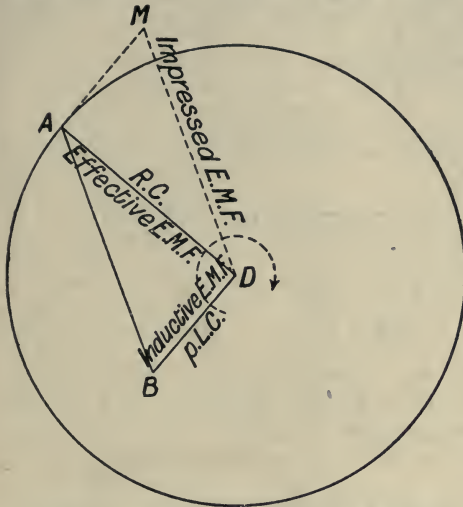

Fig. 517.—Clock Diagram for a Circuit with Inductance.

or

$$\frac{E_0}{C_0} = \sqrt{R^2 + \rho^2 L^2} \dots \dots (4)$$

This quantity is known as the **Impedance**, and may be defined as the ratio of the maximum value of the impressed volts to the maximum current. For the particular case given, that is, when the impressed volts  $E = E_0 \sin \rho t$ , we have

$$\text{Impedance} = \sqrt{R^2 + \rho^2 L^2} \dots \dots (5)$$

and since from equation (4)

$$C_0 = \frac{E_0}{\sqrt{R^2 + \rho^2 L^2}} \dots \dots (6)$$

we see that the effect of  $L$ , and of any increase in its value, is to cut down the amplitude of the current curve.

The impedance can be represented by the hypotenuse  $A' B'$  of the triangle  $A' D' B'$  (Fig. 518), the sides of which are  $R$  ( $A' D'$ ) and  $\rho L$  ( $D' B'$ ).

The angle  $B' A' D' = \lambda$ , the angle of lag, and  $\tan \lambda = \frac{\rho L}{R}$ .

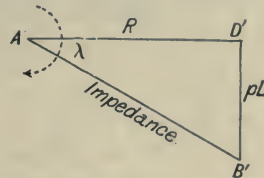

Fig. 518.—Construction for Impedance.

(I.)—That  $D M$  is in front of  $D A$ , or, which is the same thing,  $D A$  lags behind  $D M$ . In other words, the effective E. M. F. and current lag behind the impressed E. M. F. The angle of lag  $= A D M = D A B = \lambda$ , (suppose)

(II.)—That

$D M^2 = A B^2 = A D^2 + D B^2$  and, therefore

$$E_0 = \sqrt{R^2 C_0^2 + \rho^2 L^2 C_0^2}$$

There is another and still more suggestive way of looking at the problem. The influence of inductance is confined entirely to the E. M. F. and does not affect the resistance. This is indicated in Fig. 516, by describing the curve H H' H as the curve for the *effective* E. M. F. For the instantaneous value of the current we have

$$c = c_0 \text{ Sin } (\rho t - \lambda) \dots \dots \dots (7)$$

in which  $c_0$ , the maximum value of the current, is multiplied by the sine of an angle differing from  $\rho t$ , the angle for the impressed E. M. F., by  $\lambda$ , the angle of lag. Combining this with equation (6) we have

$$c = \frac{E_0 \text{ Sin } (\rho t - \lambda)}{\sqrt{R^2 + \rho^2 L^2}} \dots \dots \dots (8)$$

or

$$c = \frac{E_0 \text{ Sin } (\rho t - \lambda)}{R} \times \frac{R}{\sqrt{R^2 + \rho^2 L^2}} = \frac{E_0 \text{ Sin } (\rho t - \lambda)}{R} \times \text{Cos } \lambda (9)$$

$$\left[ \text{Since } \text{Cos } \lambda = \frac{A' D'}{A' B'} = \frac{R}{\sqrt{R^2 + \rho^2 L^2}} \text{ (by definition)} \right]$$

$$\text{whence } c = \frac{E_0 \text{ Cos } \lambda}{R} \cdot \text{Sin } (\rho t - \lambda) \dots \dots (10)$$

Since  $\text{Cos } \lambda \left( \frac{A' D'}{A' B'} \right)$  is always a proper fraction, this equation shows again, as in Fig. 516, not only that there is a lag ( $\lambda$ ) in the phase, but that the amplitude ( $E_0 \text{ Cos } \lambda$ ) of **E**, the effective E. M. F., is less than the amplitude ( $E_0$ ) of the impressed E. M. F.

With the E. M. F. expressed in this way we may use Ohm's law in its ordinary form

$$c = \frac{E}{R} = \frac{E_0 \text{ Cos } \lambda \text{ Sin } (\rho t - \lambda)}{R} \dots \dots (11)$$

which we may also write

$$\text{Current} = \frac{\text{Lagged E. M. F.}}{\text{Resistance}} \times \text{Cosine of Angle of Lag}$$

Whichever way we look at the results, it is obvious that the magnitude of  $\rho L$  relatively to  $R$  is the important physical ratio, and it is, therefore, well to notice that the disturbing factor  $\rho L$ , known as the *reactance*, does not depend upon the inductance only, but also on the frequency  $n$ , and that it can be increased by increasing *either* the inductance or the frequency. We can, therefore, get the same effect in circuits of small inductance if the frequency be high as we can in circuits of great inductance with a lower frequency. The greatest effect is produced in circuits in which both the frequency and the inductance are great. Under such conditions  $\rho L$  may be so great that  $R$  is negligible in comparison; the impedance then becomes practically equal to  $\rho L$ , and the current is inversely proportional to the product of the frequency, and the inductance; simultaneously the angle of lag becomes practically

equal to  $90^\circ$ , and the current lags a quarter of a period behind the impressed E. M. F.; in this case the two are technically said to be in *quadrature*. The most curious result of this condition of affairs is that the power spent in the circuit sinks to zero, and we have practically a *wattless current*.

It is well to repeat here that the solutions given above only apply numerically when the impressed E. M. F. follows the simple sine law. For other E. M. F.'s the solutions are more complicated, but since the E. M. F.'s can always be resolved into combinations of sine curves we have, in all cases, the general results that the effect of inductance is that the current lags behind the impressed E. M. F., and that its maximum and mean values are diminished.

**Capacity or Permittance.**—The effects of capacity, or, as it has been better called by Mr. Oliver Heaviside, *permittance*, when introduced into an alternate-current circuit, are very different from those of inductance, and, in some respects, directly opposed to the latter. The simplest case is that of a condenser  $\kappa$  (Fig. 519), connected directly to the generator  $G$  by resistances  $R$  free from inductance.

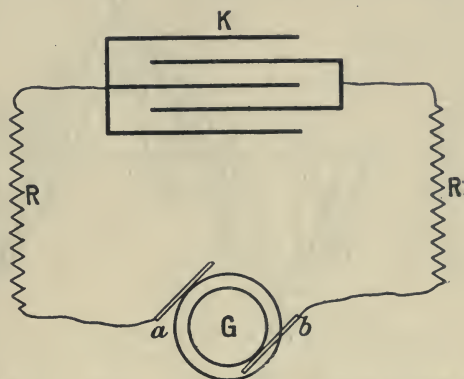

Fig. 519.—Simple Circuit with Capacity (Permittance) in Series,

In this case, if  $v$  be the alternating potential difference between the terminals,  $a$ ,  $b$ , of the generator,  $v$  the P. D. between the terminals of the condenser, whose capacity or permittance is  $\kappa$ , and  $R$  the total resistance of the connecting wires, we have the equation

$$R C + v = v$$

$$\text{or} \quad R C + \frac{q}{\kappa} = v \dots \dots \dots (12)$$

where  $q$  is the charge of the condenser at the moment considered (see page 122). Now  $q$  is the sum of all the previous charges, positive discharges and negative charges being subtracted. To obtain this summation let us again suppose that our current  $c$  is represented by the sine curve  $h h' h''$ , etc. (Fig. 520). The charge of the condenser, when a steady condition has been reached, will then pass through cyclic and periodic changes of the same period as the current, and the  $+$  charge on either plate will be at a maximum when the  $+$  current to that plate is zero and on the point of being reversed as at  $a$ . Similarly the  $-$  charge will be at a maximum when the reverse change is taking place



as at *b*. Between these two positions there will be a point *c* obviously corresponding to the position of maximum  $\frac{1}{\rho}$  current at which the charge of the condenser will be zero. It can also be shown that the numerical value of *q* at any instant can be found by the rule.

$$q = \frac{C_{-1}}{\rho}$$

where  $C_{-1}$  is the value of the current *c* a quarter of a period earlier, and  $\rho = 2\pi n$  as before. Proceeding in this way, the curve representing the varying charge, *q*, of the condenser can be drawn, and therefore the P. D. curve *v v' v''*, etc., representing  $v \left( = \frac{q}{K} = \frac{C_{-1}}{\rho K} \right)$ .

The potential difference *v* at the terminals of the generator will be

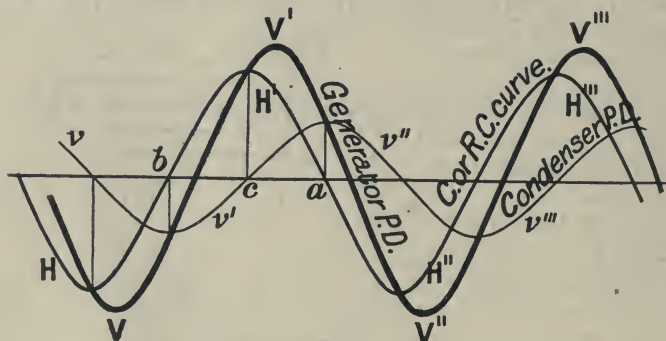

Fig. 520.—Effect of Permittance in an Alternate Current Circuit.

represented by the curve *v v' v''*, etc., which is the *sum* of the two preceding curves (see equation (12)).

To obtain an expression for the value of the current from equation (12) in finite terms assume, for reasons already given, that

$$v = v_0 \sin \rho t. \quad \dots \quad \dots \quad \dots \quad (13)$$

Take also *D A* (Fig. 521) to represent as before (see Fig. 517) at some instant of time the position and length of a line which, by revolving round *D*, will give the curve for *R C*, the P. D. required to drive the current *c* through the resistance *R*. Then *D B*  $\left( = \frac{C_0}{\rho K} \right)$  a quarter period behind *D A* will represent the condenser P. D.,  $C_0$  being the maximum value of the current. The impressed P. D., furnished by the generator, will have to be *D N*, the resultant or vector sum of these two lines obtained by completing the parallelogram *D A N B*, as shown. As before the relations of the resistance (*R*), the reactance  $\left( \frac{1}{\rho K} \right)$  and the impedance can be graphically shown by the triangle *A' D' N'* (Fig. 522).

From Figures 520, 521 and 522 we deduce the following results:—

(i.)—That the current curve is in front of the impressed P. D. curve; in other words, the effect of permittance in an alternate-current circuit is to produce a *lead* in phase of the current relatively to the P. D. The equation for the current curve may, therefore, be written

$$c = c_0 \sin (\phi t. + \lambda') \quad \dots \quad (14)$$

(ii.)—That

$$D N^2 = \frac{D A^2 + D B^2}{\dots}$$

and, therefore, 
$$v_0 = \sqrt{R^2 C_0^2 + \frac{C_0^2}{\phi^2 K^2}}$$

or

$$\frac{v_0}{C_0} = \sqrt{R^2 + \frac{I}{\phi^2 K^2}} \quad \dots \quad (15)$$

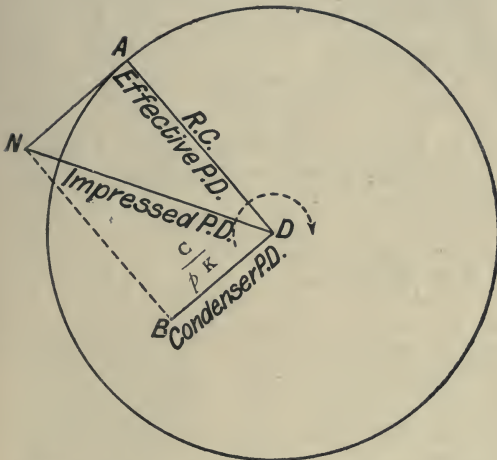

Fig. 521.—Clock Diagram for a Circuit with Permittance.

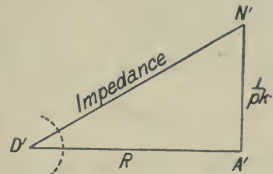

Fig. 522.—Construction for Impedance.

(iii.)—Combining (14) and (15) we obtain, in the same way as before,

$$c = \frac{v_0 \sin (\phi t. + \lambda')}{\sqrt{R^2 + \frac{I}{\phi^2 K^2}}}$$

where  $\lambda'$  is the angle of lead, and is  $\angle A' D' N'$  (Fig. 522), whence we find

$$\tan \lambda' = \frac{I}{\phi K R}$$

The quantity  $\sqrt{R^2 + \frac{I}{\phi^2 K^2}}$  is still called the *impedance*, for its effect is to diminish the maximum value of the current. It should be noticed, however, that the effect diminishes as  $K$  increases, and tends to become zero for infinitely large permittances. For very small permittances the effect is large, though if the permittance be reduced too far other phenomena may supervene. It should also be noticed that, unlike inductance, the disturbing effect of a permittance inserted in the circuit diminishes with increase of periodicity, so that at high periodicities the effect tends to become negligible.

**Inductance and Permittance Combined.**—It is easy to see from the foregoing that the effect of the permittance reactance  $\left(\frac{I}{\phi K}\right)$  is opposite

to that of the inductance reactance ( $\rho L$ ), and, without going in detail through the reasoning, we can further see that the combined effect can be obtained as shown in Fig. 523, which is a combination of Figs. 518 and 522.  $D' A'$ , as before, represents the resistance  $R$ ; along the vertical line  $A' N'$  is first measured the permittance factor  $\frac{I}{\rho K}$ , and then back from  $N'$  is measured  $N' M' =$  to the inductance factor  $\rho L$ . The line  $D' M'$  joining  $D'$  to  $M'$  gives the impedance, and the angle  $M' D' A'$  is the *angle of lead* ( $\lambda''$ ) of the current with respect to the impressed E. M. F. The equations for impressed E. M. F. current and angle of lead are

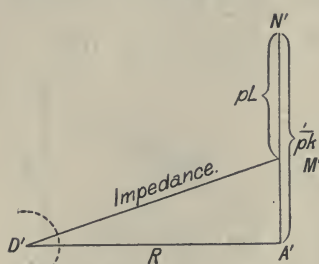

Fig. 523.—Permittance and Inductance combined.

$$E = E_0 \sin \rho t.$$

$$C = \frac{E_0 \sin (\rho t + \lambda'')}{\sqrt{R^2 + \left( \frac{I}{\rho K} - \rho L \right)^2}}$$

$$\tan \lambda'' = \frac{\frac{I}{\rho K} - \rho L}{R}$$

The effects of permittance and inductance will be *exactly* balanced if

$$\frac{I}{\rho K} = \rho L$$

or

$$\rho = \sqrt{\frac{I}{K L}}$$

When this condition is fulfilled, we have

$$\lambda'' = 0$$

and

$$C = \frac{E_0 \sin \rho t}{R} = \frac{E}{R}$$

and the equation for Ohm's law, used with continuous currents, holds good for alternate currents.

### III.—POLYPHASE CURRENTS.

In the transmission of power by the electric current over long distances the ordinary alternate current, as we shall show subsequently, possesses certain advantages as regards economy over the continuous current. Its greatest drawback, when such transmission was first attempted, was that it could not be used economically to drive electric motors, and thus reproduce mechanical energy at the distant place. It could, therefore, only be employed in lighting glow lamps or supplying energy to apparatus in which heat was required, such as for electric welding, electric furnaces, and so forth.

In 1891, however, the problem of the electric transmission of power by alternate currents was solved at the Frankfort Exhibition by the use



of currents differing somewhat in character from the ordinary alternate current. In the latter two conductors are used, the current going by one and returning by the other, and at any instant the phase of the current in the return line is opposite to that, in the out-going line, the *algebraic* sum of the two being zero. At the Frankfort experiments *three* conducting lines were used, and the currents in the three lines differed in phase from one another by one-third of a period. Thus, at a certain instant, one line would be carrying a positive current equal in magnitude to the sum of two negative currents in the other lines. An instant later the first and second line would both be carrying a positive current equal in sum to a single negative current in the third line, and so forth. The currents in all three lines are alternate ones, but they change sign at instants of time separated by intervals equal to one-third of the periodic time of alternation. The advantage of this curious arrangement of currents was that efficient electric motors could be driven by them, and thus the problem of the electric transmission of

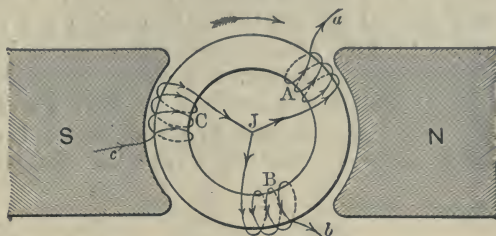

Fig. 524.—“Star” Connections of Three-phase Alternator.

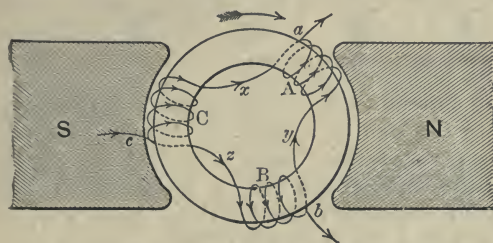

Fig. 525.—“Mesh” Connections of Three-phase Alternator.

power by alternate currents was satisfactorily solved. We may remark that the principle is not confined to the use of three currents, but can be extended to any number of currents differing in phase by a fraction of the full period corresponding to the number of currents. Such currents

are called *polyphase currents*; the phases most used in practice are either two phases or three phases, the currents being known as di- and tri-phase respectively.

**Generators of Three-phase Currents.**—What is really meant by polyphase currents may, perhaps, best be illustrated by considering, in an elementary manner, how such currents may be generated, and for this purpose we select three-phase currents. Let there be three coils, A, B, and C (Figs. 524 and 525), at equidistant positions on the ring armature core of a two-pole dynamo. The arrow-heads are intended to represent the directions of the induced E. M. F.'s at the instant considered, the rotation of the ring being clockwise. In coil A the E. M. F. is increasing, in coil B it is

diminishing, but is in the same direction as in A, whereas in coil C it is also diminishing, but is in the opposite direction to what it is in coils A and B. As the ring rotates it will be evident that the three coils have similar alternations of E. M. F. induced in them, but that they reach their zero and maximum positions at different instants of time; in other words, though the induced E. M. F.'s are similar, they *differ in phase*.

Theoretically there are several ways in which these coils may be employed to supply polyphase currents to external circuits, but we need only refer at present to the two which are represented in Figs. 524 and 525. In Fig. 524, which shows what has been called the "star" method of connection, the three corresponding ends of the coils are joined together at a common junction J, and the other three ends, *a*, *b*, and *c*, being connected to three insulated rings, can then be used to supply three separate line wires with three-phase currents. At the instant

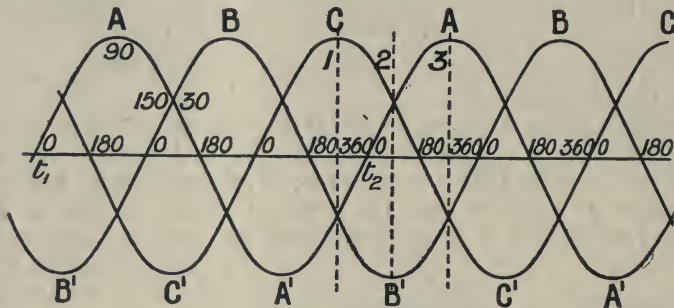

Fig. 526.—Curves for Three-phase Currents.

represented *a* and *b* are giving current to their lines, whilst *c* is receiving from its line a current equal to the sum of *a* and *b*. Another method of connection, which has been called the "mesh" method, is shown in Fig. 525, where internally the end of one coil is connected to the beginning of the next, as in an ordinary Gramme ring. Here also, if the points *a*, *b*, and *c* be joined to collecting rings, three-phase currents can be supplied to outer circuits. In this case, at the instant represented, the currents sent out from *a* will be equal to the sum of the currents in *x* and *y*, and intermediate between them in phase. The current from *b* will be equal to the difference of the currents in *x* and *y*, and of intermediate phase, whilst similarly the current received by *c* will be equal to the sum of the currents in *x* and *z*.

It is also possible to have combinations of star and mesh groupings. For instance, the points *a*, *b*, and *c* in Fig. 525 may not be directly connected to the outgoing lines, but joined to coils appropriately wound upon the ring, the other ends of these coils being put in connection with the line wires. Each corner of the mesh will then have an active

coil interposed between it and the line, and these added coils will thus be "star" connected by the mesh.

The currents in the three lines generated by any of these methods would differ in phase by one-third of a period, or, as it is usually said, by  $120^\circ$ . If of sine form they would be represented by the three curves A, B, and C of Fig. 526,

where each curve is of exactly the same shape, but is placed so as to differ in phase from the other two by the required interval. The whole period for any one of the curves is represented on the time line by a length equal to  $t_1$ ,  $t_2$ , which is taken as equivalent to  $360^\circ$  of angular movement of the revolving line from which the curves are drawn. It should be noticed that if vertical lines 1, 2, 3, etc., are drawn across, the sum of the ordinates on the positive side cut off by any such line is equal to the sum of the ordinates on the negative side. Thus, at 1 we have,  $C = B + A$ ; at 2,  $C + A = B$ ; and at 3,  $A = C + B$ ; where A, B, and C are taken to represent the ordinates of the respective curves. Thus the algebraical sum always equals zero.

**Generators of Two-phase Currents.**—The other class of polyphase

currents in common use are known as *two-phase* currents. They are produced when the coils of the generator are so placed that the E. M. F.'s set up in successive segments differ by a quarter-period, or  $90^\circ$ . In such cases they are frequently described as being in *quadrature*. The methods of producing such currents with a ring-wound armature in a two-pole field are shown diagrammatically in Figs. 527, 528, and 529, the only difference

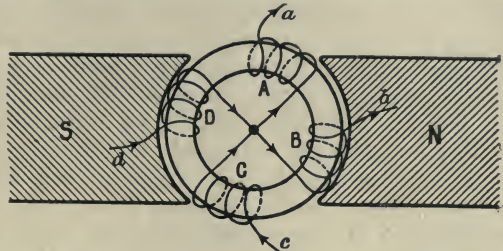

Fig. 527.—Star Connection of Two- (or Four-) phase Alternators.

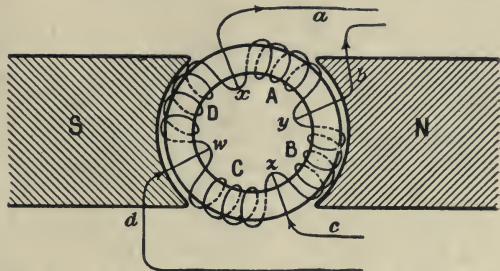

Fig. 528.—"Mesh" Connection of Two- (or Four-) phase Alternators.

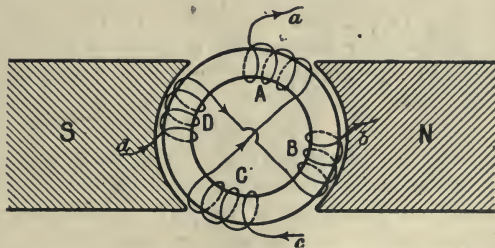

Fig. 529.—Generator Connections in Quadrature for Two-phase Working.



between the figures being in the method of connecting the coils internally and to the outer circuits.

Four coils, A, B, C, and D, are shown upon each ring. In Fig. 527 we have the "star" method of connection, similar to that shown in Fig. 524, for three-phase currents, whilst Fig. 528 shows the "mesh" connections, similar to the connections in Fig. 525. Fig. 529, however, shows a combination which is not possible with the three-phase coils of Figs. 524 and 525. In this figure the coils A and C, which are opposite in phase at every instant, are so connected that their E. M. F.'s are added to supply an external circuit from the points *a* and *c*, whilst the two other coils B and D are similarly connected to one another, but *not* to A or C, so as to supply an entirely independent circuit attached to the terminals at *b* and *d*. The currents in these two external circuits so fed are ordinary single-phase alternate currents, having, however, the same periodic time, but differing in phase by a quarter-period. Their utility consists in the

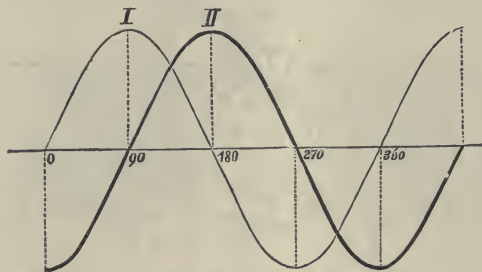

Fig. 530.—Alternate Currents in Quadrature.

fact that they may be used either quite separately or in combination, as circumstances may require. When combined, they are especially useful for motor purposes. The current in these two circuits can be represented by the curves I and II of Fig. 530.

The figures, as drawn, each require four conducting lines in their external circuits, but in Fig. 529, where internally the two circuits are quite independent, it is possible to reduce the number to three by making a common return wire do for two adjacent coils, say C and D.

#### IV.—SIMPLE POLYPHASE CIRCUITS.

So far we have dealt only with the generator, but it is obvious that the outer conductors must be connected in some way to correspond with the conditions of supply. Where they are used to supply current to polyphase motors and transformers the connections of the machines or apparatus are suitably arranged. When, however, the apparatus to which the current is delivered consists, as in glow-lamp lighting, of numerous separate pieces, each of which has two terminals, and no more, some care must be taken in arranging the circuits. Two cases of three-phase distribution will be sufficient for illustration.

In Fig. 531 the three-phase generator, G, is "star" connected, the common junction or neutral point, as it is sometimes called, being *J*. The receiver R consists of three groups of glow-lamps, one for each of

the line wires  $a$ ,  $b$ , and  $c$ . In the diagram the lamps are strung between bars  $A'$ ,  $B'$ , and  $C'$  and a common omnibus or junction bar  $J'J'J'$ . This junction bar  $J'J'J'$  is the electrical equivalent of the junction  $J$  in the generator, whilst the bars  $A'$ ,  $B'$ , and  $C'$  take the place, in the receiving apparatus, of the terminals  $A$ ,  $B$ , and  $C$  of the generator.

In Fig. 532 the three coils of the generator  $G$  are "mesh" connected

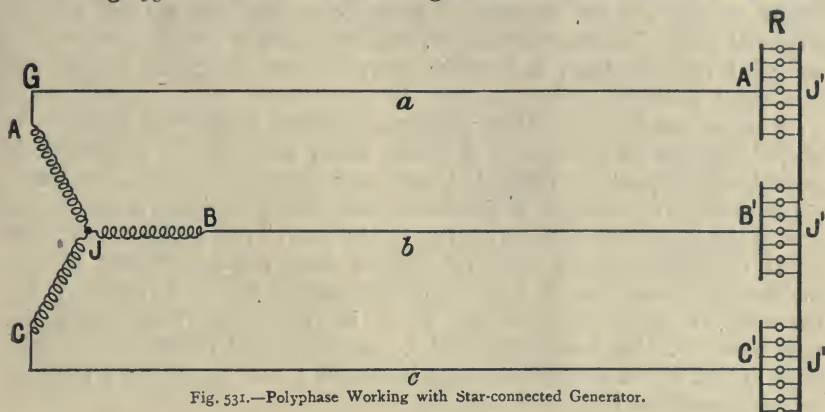

and deliver current to the line wires from the terminals  $A$ ,  $B$ , and  $C$ . The receiver  $R$  is again represented as consisting of a load of three groups of glow-lamps, but they are now so arranged as to reproduce electrically the "mesh" connections of the generator. In examining the details it should be noted that the thick lines  $A'A'$  are the electrical

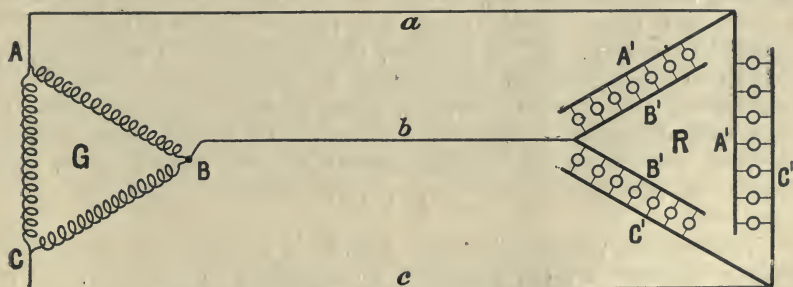

equivalent of the terminal  $A$ ,  $B'B'$  the equivalent of  $B$ , and  $C'C'$  of  $C$ . There is no common junction bar required as in the preceding figure.

It is obviously desirable that in grouping the lamps at the receiving end the three groups should consist of lamps requiring the same total current as nearly as possible. But, when the load is distributed amongst a great

number of individual consumers, as in glow-lamp lighting from a central station, the equalisation of the load may offer almost insuperable difficulties, especially when many of the smaller consumers are each placed upon one only of the three available circuits. Three-phase distribution is, therefore, not commonly employed when the greater part of the load consists of glow-lamps. Still, glow-lamps can be supplied from three-phase circuits, and are so supplied when they form only a small part of the total load. There are, however, various kinds of transformers which we shall describe later, and which more or less effectively banish the difficulties indicated.

The connections for other polyphase systems follow the lines of the above diagrams for glow-lamp or similar loads, although the combinations possible are numerous. When the coils of the generator are star or mesh connected, the terminals of a bi-terminal load should be similarly connected, and in the former case it is an advantage to "earth" the common junctions (*J*) of the generator and the load. Where there are independent circuits in the generator (as in Fig. 529) the number of lines required for transmission may be reduced. Thus in Fig. 529, two contiguous terminals, *e.g.* the terminals *a* and *b*, may be joined to the same transmission line, and a six-phase generator may be joined up similarly to three transmission lines instead of six.

#### V.—ALTERNATORS.

In most forms of continuous-current dynamo machines the E. M. F.'s and currents generated in the wires of the armature are alternately in opposite directions, and are, in fact, alternate E. M. F.'s and currents. As regards the outer circuit these are rendered unidirectional by an appropriate commutator. If, however, the commutator be suppressed, and connection made with the outer circuit by sliding contacts, we have in that circuit the alternate currents, some of whose properties, etc., we have been discussing. Machines constructed to furnish these alternate currents are known as alternate-current dynamo machines, or, more briefly, as *alternators*, and form a very important class of electric generators.

Theoretically, the only differences between a continuous-current dynamo and an alternator are the absence of a commutator in the latter, and the fact that it cannot furnish the current to excite its own field-magnets, if these be electro-magnets. It might, therefore, be supposed that the two classes of machines would not differ much in general design and appearance, and in some instances this is so. But in the majority of cases the design and construction of an alternator differ materially from those of a continuous-current machine, for the suppression of the commutator, although removing a fruitful source of weakness and expense, introduces new com-



plications which must be faced, and it will, therefore, be convenient to explain here the details of a few leading historical types of alternators.

**Historical.**—One of the earliest alternators generating large currents, and one which for some time was widely used for lighthouse purposes, was the Alliance machine, represented in Fig. 533. It consisted of eight sets of compound horse-shoe magnets fixed symmetrically, as shown; each compound magnet weighed about 45 lbs. The machine, it will be readily seen, is, in principle, an assemblage of Clarke machines (*see* page 473),

and has twice as many coils as magnets; thus, with twenty-four magnets there are forty-eight coils. One end of the total length of wire was fastened to the axis, and was, therefore, in electrical connection with the frame of the machine; the other end was fastened to a metal ring surrounding the shaft, but insulated from it. A spring which pressed on this ring conducted away the current. Every time a coil passed a pole the current changed, hence there were sixteen changes for each coil to each revolution, and as the machine was driven at more than six revolutions per second, there

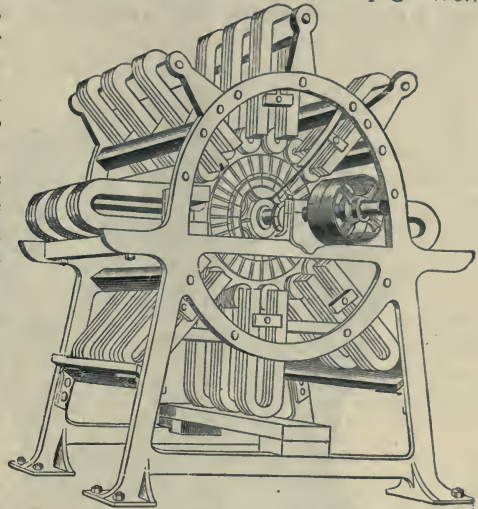

Fig. 533.—The Alliance Machine.

were a hundred per second; as each full period involved two such changes, the periodicity was 50 periods per second. The first machine of this kind had commutators; but it was only after the machine was modified by Van Malderen, who abandoned the commutator so as to use the rapidly alternating currents, that it became of practical value. Alliance machines were used in the electric lighting on Mont Valérien and Montmartre during the siege of Paris in 1871, and have been used in some light-houses on the coast of France ever since that date. Nevertheless, this form of machine is complicated and costly, and not easily repaired when any part is injured. It was much improved by De Meritens, and others.

The development of arc lighting by electric candles in 1876 required the generation of fairly large alternate currents, and gave an impetus to the construction of alternators, which was continued later by the introduction of lighting by glow-lamps. Several typical machines were produced to furnish the desired currents.

Gramme, who did so much for the continuous-current machine, constructed the alternator shown in Fig. 534. Upon a cast-iron base *B* two cast-iron supports *D*, of almost circular form, were attached together with eight brass rods *E* and an iron stay, which served to give the whole greater solidity. To this frame the coils *a b c d* were fastened. The whole of the cylinder of coils was covered with a wooden frame *S*; *F* was a steel shaft which carried the eight electro-magnets *K* by means of cast-iron sockets and octagonal plates. Each of these electro-magnets had a pole-piece of soft iron rounded at the outer surface, and reaching

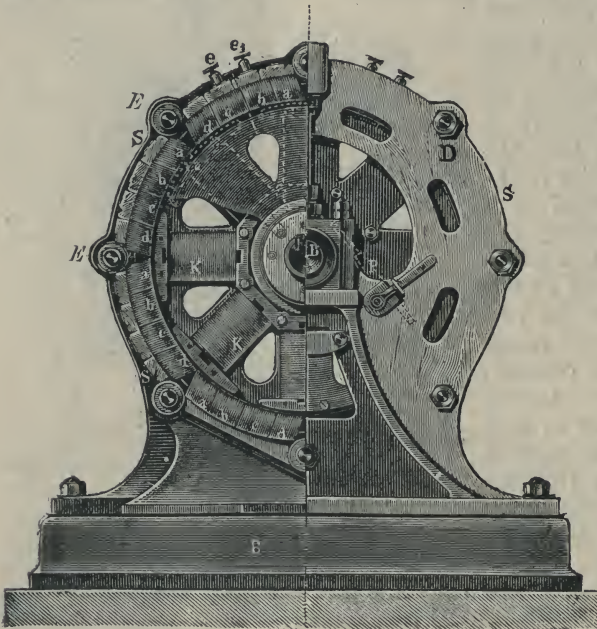

Fig. 534.—Gramme's Alternate-current (Polyphase) Generator.

beyond the electro-magnets, so that very little space was left between the pole-pieces of two magnets. Two thin discs fastened to the different magnets protected them against the effect of centrifugal force. Upon the shaft were two insulated discs, and upon these the brushes *P* slid. They served the purpose of conducting to the electro-magnets a current usually supplied by a small auxiliary Gramme machine. The current was so sent round the different electro-magnets that the poles directed outwards were alternately of south and north polarity. The eight groups (each group consisting of the wires of four coils) were not connected to form one large coil, as in the Gramme ring, but the wires of each coil were led to binding screws *e e*, fastened upon the wooden cover *S*. By this arrangement the machine could give thirty-two separate currents. In practice, however, the eight coils marked *a* were suitably connected to throw all their E. M. F.'s in the same direction into a single circuit, and three other circuits were formed from the eight coils marked *b*, *c*, and *d* respectively. The successive coils on any one of these circuits were under exactly opposite inductions at the same instant, and, therefore, if properly connected these inductions could all be made to

round the different

assist one another. In this manner four separate currents were obtained, in each of which alternate pressures of the same strength were produced.

The machine was really one of the earliest, if not the earliest, poly-phase machine, the phase difference of successive circuits being  $45^\circ$  or  $\frac{1}{4}$ th of a period. No use, however, was made of the advantages obtainable from these phase differences, each of the four circuits being worked independently as a simple alternate current circuit. The machine shown in Fig. 534 fed sixteen Jablochhoff candles, each of 1,000 candle-power, and requiring sixteen h.p. altogether. It cost, including an auxiliary exciting machine, 10,000 francs = £400; its length was thirty-five inches, breadth thirty, height thirty-one; the maximum speed was 600 revolutions per minute, and the weight 1,430 pounds. As the machine supplying the current for the electro-magnets was, as a rule, separate from the principal machine, the slightest fluctuation of current in the former produced considerable disturbances in the latter, and consequently the lights were not steady. Subsequently, Gramme dispensed with the independent generator by uniting the two machines on one driving axle, and to this machine he gave the name "Auto-excitatrice."

The Auto-excitatrice not only gave better results than the old machine, but also cost less. A machine weighing 1,034 pounds furnished currents for twenty-four Jablochhoff candles of 200 to 300 candles each, or sixteen lights of double that power. A machine for feeding twelve of the smaller lamps weighed 616 pounds.

Alternate-current machines, similar to those of Gramme, were constructed by Zipernowsky, of the firm of Ganz and Co., of Budapest. The chief difference consisted in the turning of the axis of the stationary armature coils round through a right angle, so that this axis was directed radially instead of circumferentially. This method of arranging the armature coils is followed in some of the large alternators of the present day.

**Siemens' Alternate-current Machine.**—Siemens obtained alternate currents by using flat coils rotating in powerful magnetic fields. The alternate-current machine built by Siemens and Halske, together with its small continuous-current generating machine, is shown in Fig. 535. To the base plate of the machine were screwed two cast-iron supports, held together by a cross bar at the top; each support carried twelve electro-magnets, the coils of which were so arranged that whenever a current flowed through each possessed the opposite polarity to its neighbouring as well as to the opposite magnet. The magnetic flux across the gap was, therefore, alternately in opposite directions in consecutive pairs of electro-magnets. Between the poles of these electro-magnets rotated a disc, which carried the bobbins, the cores of which were made of wood. When the disc rotated every coil swept across the lines of the oppositely directed fields distributed round the gap. The currents induced in a



coil would, therefore, change their direction as the coil passed from one magnetic pole to the next. The machine had as many coils as there were pairs of electro-magnets, every two opposite magnets constituting a pair; there-

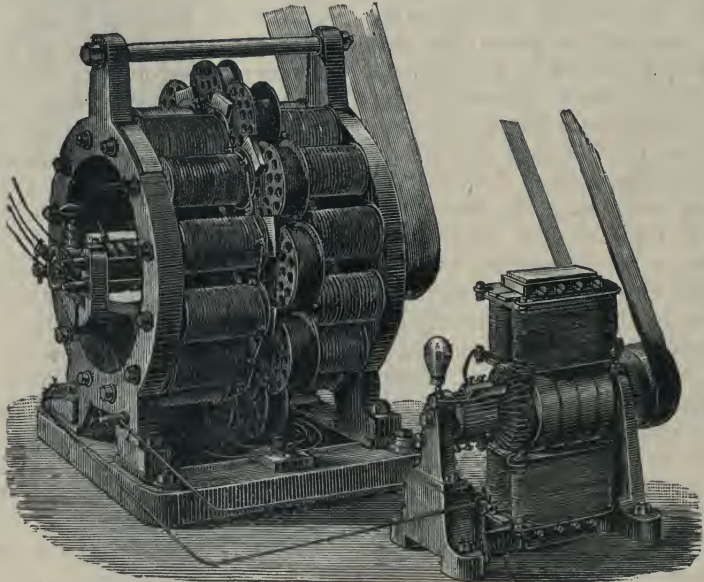

Fig. 535. —Siemens' Alternate-current Machine, with separate Exciter.

fore, the change of current occurred in all the coils at one and the same time. The currents induced in the coils were conducted to a couple of rings fastened to the axis of the machine. The electro-magnets were

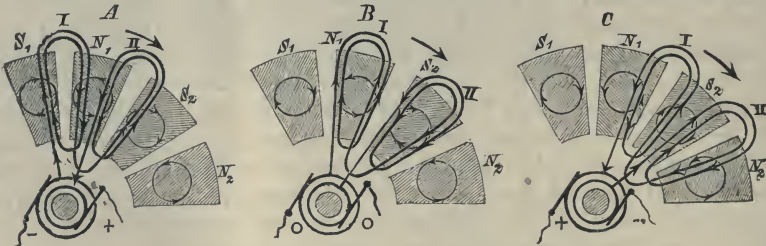

Fig. 536. —Diagrams of Siemens' Alternate-current Machine.

excited by the small auxiliary machine. The mode of action of the machine is shown in Fig. 536, A, B, C; *s* and *N* indicate the magnetic poles, and the outer arrow indicates the direction of rotation. In the position A the coil I moves away from the pole *s*<sub>1</sub>, and consequently a current will be induced that flows clockwise; at the same time coil I

approaches  $N_1$ , and a current clockwise will here, too, be induced, the poles  $N_1$  and  $S_1$  mutually assisting each other. Coil II moves away from  $N_1$  and approaches  $S_1$ , and has, therefore, currents anti-clockwise. If, now, the coils I and II were simply connected with each other, the E. M. F.'s induced in the coils would neutralise each other and no currents would flow. This, however, as shown in the figure, is prevented by so connecting the coils that the E. M. F.'s are in the same direction in the electric circuit, as can easily be seen by following the arrows. The currents generated are conducted by the springs + — into the outer circuit. Here we have taken into account only one row of magnetic poles; but in reality the coils I and II move between two rows of magnets with their opposite poles facing each other, thus the south pole  $S_1$  has a north pole opposite it; and the north pole  $N_1$  has a south pole opposite, and so on. The changes in the inductions as the coils sweep past successive poles can be followed in B and C. In B the E. M. F.'s momentarily sink to zero, and there is no P. D. between the rings; in C they are exactly the reverse of what they are in A, and the P. D. between the rings is

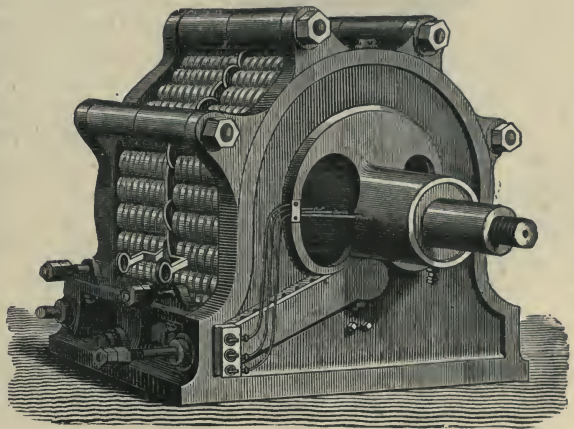

Fig. 537.—The Ferranti-Thomson Machine.

oppositely directed. Each pair of coils was similarly connected to the rings, the six pairs being electrically in parallel. Alternate currents were, therefore, led into the outer circuit by the brushes in sliding contact with the rings.

**The Ferranti-Thomson Generator.**—The early form of this machine, which did good work during the pioneer stages of the development of glow-lamp electric lighting, is represented in Fig. 537. It was the result of the labours of Sir William Thomson, S. Z. de Ferranti, and Alfred Thomson.

The armature is shown separately in Fig. 538. The shaft carried two blocks insulated from each other and from the shaft; between these blocks there was a brass ring, also insulated, to which at regular intervals the copper bands of the armature were attached. The eight coils of the armature consisted of copper bands of 1.25 inches breadth and 0.07 inch thickness, all having electrically the same value. The bands

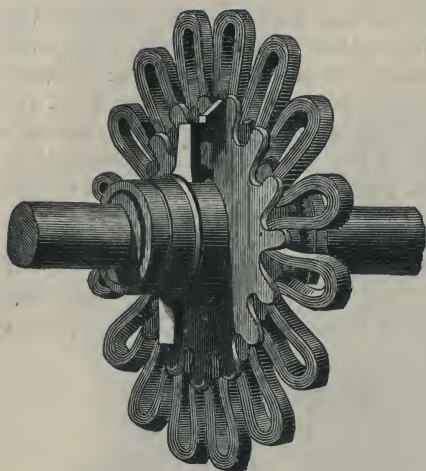

Fig. 538.—The Ferranti Armature.

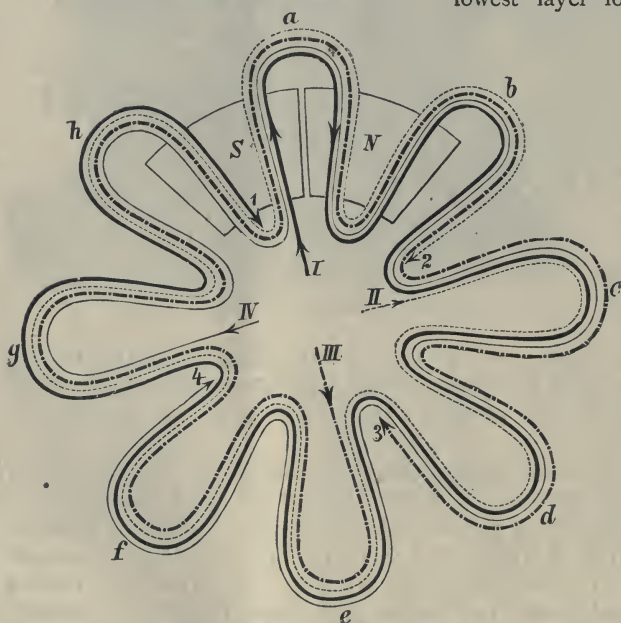

Fig. 539.—Diagram of the Ferranti Armature.

were of the same length, and had the same shape. The construction of the armature is best seen in Fig. 539. To prevent complication, only eight coils of four bands each are represented. The first copper band I began in the curves *a* and *b*, and was continued over *c* and *d*, but so that in curve *c* it came *over* the second copper band II, which commenced at curve *c*, and for this curve and the curve *d* formed the lowest layer. Copper bands I and II were continued together until they reached *e*; here the copper band III commenced and formed the lowest layer for curves *e* and *f*.

The three copper bands were now continued till they reached curve *g*, where the fourth and last copper band commenced. The curves *g* and *h* now consisted of all the four bands. The copper band I ended at curve *h*, but the three other bands continued their way; the second band ended at curve *b* at 2, bands III and IV ended at 3 and 4 in curves *d* and *f* respectively.

Each copper band

was conducted through all the curves in such a manner that it formed the first layer in two curves, the second layer in the two next curves, then the third layer, and finally the fourth layer, where it ended above its starting point.



The same length and a similar course are obtained in this manner for all the bands. The several copper bands I 1, and I 12, etc., were insulated from each other. The armature had a diameter of thirty-six inches, and made 1,000 revolutions per minute. Upon the shaft at both sides of the armature two collecting rings were fixed. One of these was connected with a brass ring, the other with the ends 1, 2, 3, and 4 of the copper coils. The copper bands started from the brass ring, at the points I, II, III, and IV. To connect the different parts with each other massive pieces of metal were used instead of wires. The currents induced in the copper bands were not conducted by brushes into the outer circuit, but here also, instead of brushes, metal pieces

were used, being pressed by springs against the rings. When we compare Fig. 539 with Fig. 536 we find that the principle is practically the same. For coil *a* (Fig. 539) the poles S N of the enclosing magnets are shown, and the directions of the current induced in the copper are indicated in band I 1, of curve *a* by the arrows. The remaining copper bands I 12; III 3; and IV 4 of curve *a* will have their currents in the same direction. Owing to the arrangement of the copper bands, and in consequence of

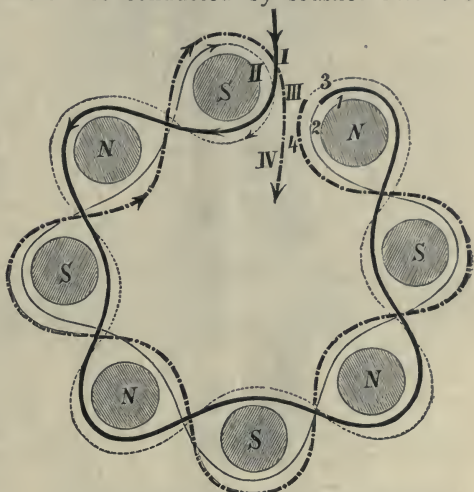

Fig. 540.—Diagram of Ferranti's Electro-Magnet.

the alternating arrangement of the surrounding magnets, at every moment during rotation, currents will be induced in all the curves passing in the same direction through the armature. Therefore, one of the collecting rings connected with the ends I, II, III, and IV will receive currents from all the coils, and the other collecting ring connected with 1, 2, 3, 4 will return these currents from the outer circuit. If the motion continues a currentless interval will occur, and then a current of opposite direction, and so on. Ferranti arranged the turns of his armature in continuous order, whilst Siemens divided them into groups.

Facing the armature on each side thirty-two magnets were arranged. The iron cores were cast in one piece with a half-frame of the machine. The two halves faced each other, and were held together by six horizontal bolts. The coils of the electro-magnets were copper bars, having a section from 0.3 to 0.35 square inch. Fig. 540 shows the manner of coiling for eight magnets, each conductor forming one layer

on the magnet core, and the different conductors being in series. The current was introduced into the coils of the electro-magnets by means of the terminal ring, seen on the left hand of Fig. 537, and flowed through one series of magnets, then through the second series of magnets, and then left the field coils by means of the second ring of the machine. At a speed of 1,000 revolutions per minute a current of 2,000 amperes, with an E. M. F. of 200 volts, was produced. The machine was intended

to feed glow-lamps, therefore its resistance was made as small as possible.

**Gordon's Alternator.**—A machine of historical interest, as being the first large direct-coupled alternator built in England, was the Gordon Alternator, of which the first example was constructed by the Telegraph Construction and Maintenance Company in 1882 to light their works at Greenwich. A little later similar machines were installed in London at the Paddington Station of the Great Western Railway.

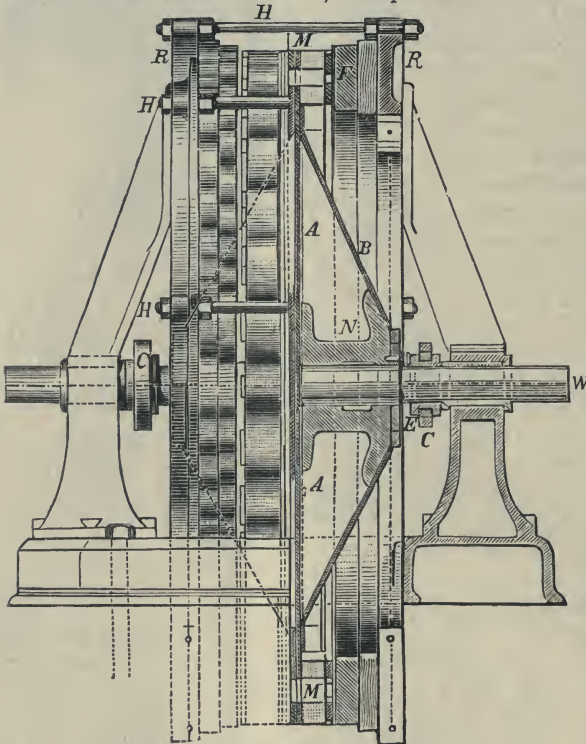

Fig. 541.—The Gordon (Di-phase) Alternator.

In this machine the electro-magnets rotated, whilst the armature was fixed. It is represented in Fig. 541, in which one half of the figure represents a cross section, the other half a side view. The shaft *w* revolved in two bronze bearings, and carried in the middle two wrought-iron discs *A*, nearly nine feet in diameter. To each of these a flat cone *B* of strong sheet iron was riveted, and the vertex of this was fastened to a kind of nave *N* attached to the shaft. The cone *B* was for the purpose of stiffening the disc *A*. In the space between the nave and axle-bearing, rings *E* were fixed upon the shaft. These rings had grooves in them filled with vulcanite, to carry and

insulate the contact rings *c*. The rings *c* were made of bronze, and were intended, by the aid of the copper brushes which slid upon them, to conduct the current into the electro-magnets. The current for this purpose was supplied by two auxiliary Bürgin machines. Each of the discs *A* carried on its circumference thirty-two electro-magnets, the coils of which had currents passing through them in such a manner that a north and south pole recurred alternately in the circle. The magnets were put in series at both sides of the field-magnet disc *A*. The magnet cores were made of wrought iron and penetrated the combined discs, so that one pole was on one side of the disc and the other pole on the other side. The insulated wire was wound on brass spools, which were slipped over the cores. Upon the massive cast-iron supports (Fig. 541) strong iron rings *R* were fastened, and held in position by the horizontal bars *H*. At the inside of each cast-iron ring sixty-four armature coils *F* were fixed, and were insulated from the ring by means of wooden plates. The total number of armature coils was therefore 128. The coils were grouped into two different circuits, distinguished from one another by the coils being painted alternately red and blue, the currents in the two circuits being in quadrature. The iron cores of the coils were wedge-shaped, and the insulated copper wire of the spools had a cross section of .075 square inch. The coils were fixed by means of their cores to the iron rings, from which they were insulated by the wooden pieces already mentioned. The coils had the sides facing the rotating magnets covered and protected by German silver sheets, from which the electro-magnets were only one-eighth of an inch distant. The copper wires had a double coating; every coil was dipped in shellac varnish, and then dried at a high temperature, and finally painted with asbestos paint. There were in all, as previously mentioned, 128 stationary bobbins (sixty-four on each side), and they were acted on inductively by thirty-two electro-magnets having sixty-four poles, so that there were twice as many bobbins as magnet poles. If the machine had had the same number of bobbins as electro-magnet poles, the inductive action of one bobbin on the next one would have been so strong as to materially reduce the efficiency of the machine. The rotating discs, with their electro-magnets, weighed nearly seven tons, and the total weight of the machine was nearly eighteen tons.

On looking at Fig. 542, we see that the rings carrying the armature coils consisted of several pieces; the small middle piece at the upper portion of the ring, placed between the two side segments, could be easily removed, so as to allow the magnets to be repaired if they became damaged. The following is from a published report of the results obtained with this machine. The generator supplying the electro-magnets with current was set in motion by a five-horse-power steam engine, the current thus obtained being twenty-five amperes. The large steam



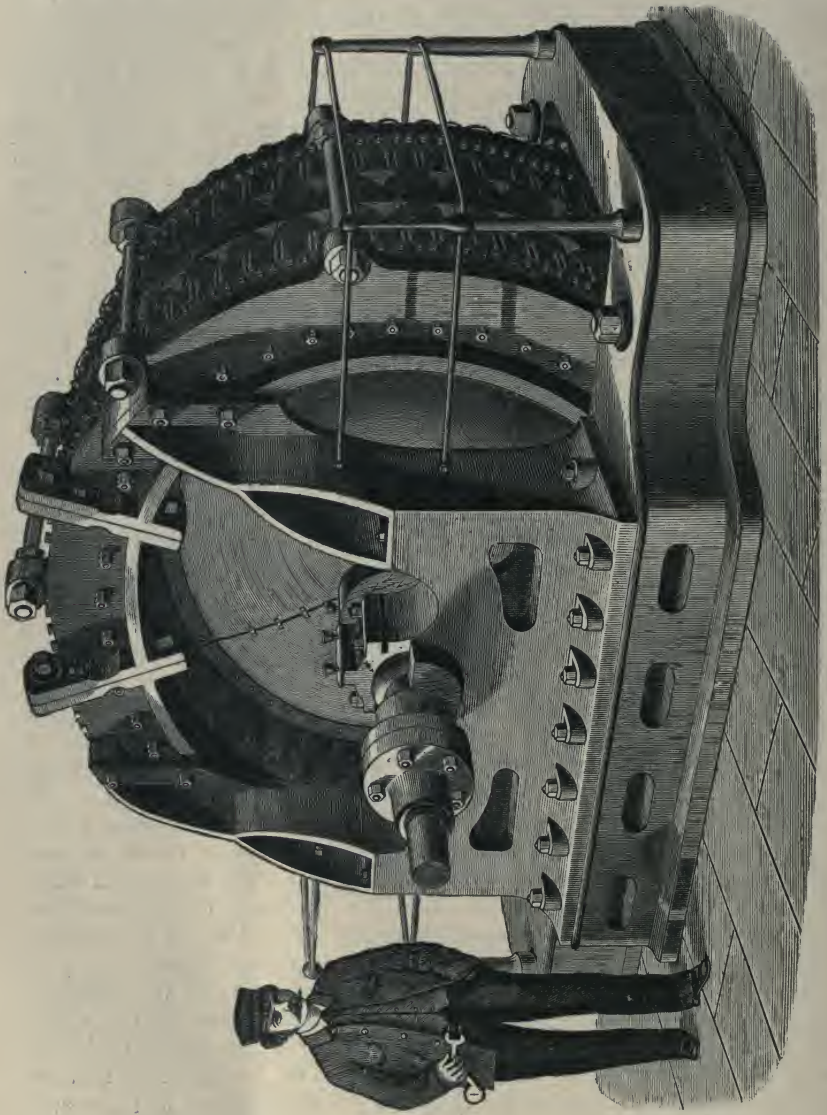

Fig. 542. — The Gordon (Di-phase) Alternator.

engine which worked the alternator required 170 horse-power—that is, for principal and auxiliary generators 175 horse-power were required. The alternate current had a potential of 103 volts, and supplied 1,400 Swan lamps in two rows. Each lamp was estimated to have a resistance of thirty ohms, and to give a light equal to twenty-two or twenty-three candles. The total resistance of the machine was equal to 0.0985 ohm, and the resistance of the circuit to 0.006 ohm, which gives a current of about 1,030 amperes. This amounts to 180 candles for each horse-power. The proportion of electrical work done by the alternate current machine to the work measured in the cylinder of the steam engine was 0.816.

The Société Anonyme d'Electricité constructed a large Gérard alternator, in which the field-magnets rotated and the armature coils were stationary; and Ganz and Co., of Buda-Pesth, constructed large alternators, designed by Mechwart and Zipernowsky, direct-coupled to steam engines of 150 horse-power. These machines will be found described in previous editions of this book.

The alternators so far described may be regarded as pioneer machines in the distribution of electric power by alternate currents. They have been displaced in later years by large machines of much greater output, in designing which many new problems have had to be faced. We shall return to the subject in a later chapter.

#### VI.—RECTIFIERS.

In many of the applications of the electric current, more especially for electroplating and electro-chemical work generally, for charging secondary batteries, for external lighting with arc lamps, etc., the alternate current is either useless or is much less advantageous than the continuous current. Nevertheless, it may happen in certain districts that the only form of electric power available from the public supply mains is alternate current primarily intended for lighting and power purposes only. In such cases it is very important to be able to transform the available alternate current power to the desired continuous current power, and various "kinetic transformers" for this purpose will be described in the chapter on "Electric Motors" (Chapter XVI.).

There are, however, types of simpler apparatus which may be used where only small amounts of power are involved or where a pulsating unidirectional current may take the place of a steady continuous current, and this chapter may well close with some reference to such apparatus.

**Revolving Commutators.**—The commutator of a continuous current dynamo is the most widely used form of rectifying apparatus in existence, for it rectifies the alternate currents generated on the armature and delivers to the brushes a continuous and steady unidirectional current. This,

however, is an essential part of the continuous current generator, and we are now dealing with apparatus which, taking single-phase alternate currents from a pair of leads, will transform them into unidirectional currents.

The simplest form of such separate apparatus is, perhaps, a two-part commutator driven at the proper speed by a "synchronous motor"\* operated

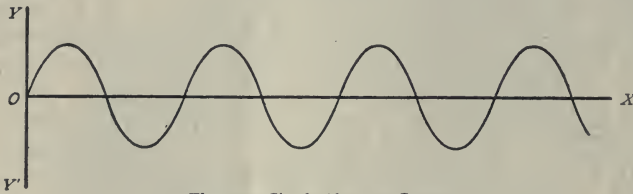

Fig. 543.—Simple Alternate Current.

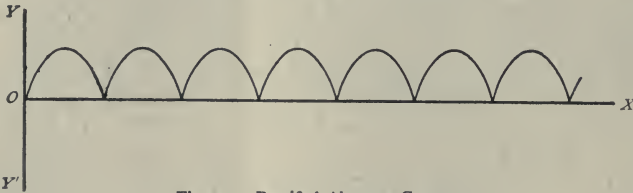

Fig. 544.—Rectified Alternate Current.

in Fig. 512, the time is measured horizontally along  $o x$  and the value of the current vertically parallel to  $y y'$ . In Fig. 543 is depicted an ordinary single-phase sinusoidal alternate current. The terminals of the mains supplying this current are connected through slip rings to the sections A and B of a two-part commutator (Fig. 545). If now the commutator be driven at such a speed and the sliding brushes,  $a$  and  $b$ , be so placed that whenever the value of the current sinks to zero the brushes pass from A to B, or *vice versa*, then these brushes will deliver to any simple circuit to which they are connected currents such as are represented in Fig. 544.

To satisfy the conditions, it is obvious that the commutator must be driven accurately at a speed in revolutions per second equal to the periodicity of the current. This is accomplished by mounting on the axle  $x$  the rotor of a synchronous motor which can only run at the required speed and no other. In addition, the brushes  $a$  and  $b$  must be so set as to cross the insulating lines of the commutator exactly at the right moment. If

by a current derived from the same leads. The action of such a commutator has already been referred to in the last chapter (see pages 484 and 485), but for our present purpose is better shown in Figs. 543 and 544, in which, as



Fig. 545.—Two-part Commutator or Collector.

\* This term will be explained in Chapter XVI.



the brushes are not set and maintained in the right position, there will obviously be sparking on the commutator, which may be serious if the voltages handled are high, and if, owing to varying conditions, the currents in the circuit connected to *a* and *b* have varying phase relations with the P. D. impressed on the circuit. For it must be remembered that though these currents are unidirectional they are pulsating and not continuous, and therefore reactances due to inductance and capacity will be set up in their circuits.

Mr. S. Z. de Ferranti some years ago devoted a great deal of attention to commutators designed on these principles for use on arc-lighting circuits, and invented many ingenious devices for rendering them automatic under varying conditions of the supply and load circuits. They are not now, however, very much used, as they have been superseded by the wider use of kinetic transformers; and, moreover, it is very difficult, indeed, to suppress entirely the vicious sparking on the commutator.

An example of such a rectifier, which can be used satisfactorily with currents up to 20 or 30 amperes, is shown in Fig. 546. The particular design is due to Dr. Morton, and it is manufactured by Messrs. Newton & Co. A synchronous alternate current motor *M* drives the split tube commutator *C*, to which the alternate current to be rectified is supplied by two of the brushes, and from which the rectified current is taken away by two other brushes sliding on slip rings connected to the two sides of the commutator. The synchronous motor is supplied with alternate currents from the same circuit, and therefore drives the commutator at the exact speed required. It is constructed as an ordinary shunt-wound continuous current motor with a commutator, but with laminated fields. Such a motor, as will be shown later (*see* Chapter XVI.), can be run with a single phase alternate current if certain difficulties, of which sparking at the commutator is the most serious, can be overcome. In this case, as the load on the motor is very light and almost negligible, being only the friction of the brushes, bearings, etc., these difficulties are minimised. For starting purposes the voltage at the motor terminals is

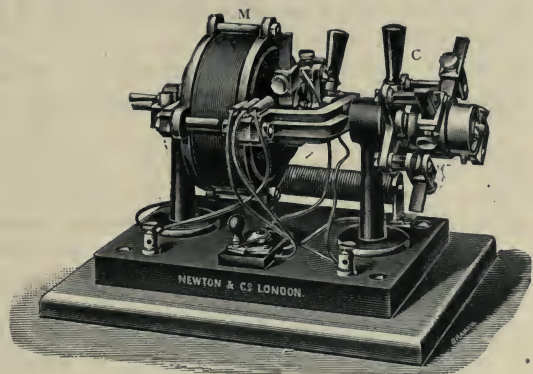

Fig. 546.—Dr. Morton's Commutator Rectifier.

cut down by an external resistance, which is cut out when the motor has run up to speed. For running only about one-fourth of the supply voltage is put on the armature.

**Electrolytic Rectifiers.**—These depend upon an entirely different principle. If one of the electrodes of an electrolytic cell or voltameter (*see* Chapter V.) be made of aluminium, then it is found that the current can pass freely when the aluminium is the cathode or negative plate, but that it experiences a very great resistance if the aluminium be the anode or positive plate. The effect is due to the formation of a film of insoluble oxide of very high resistance on the aluminium, where the current passes from metal to liquid and is most marked when the electrolyte is alkaline. Such a cell, properly proportioned, and placed between single-phase alternate current mains carrying P. D.'s represented by the curves in Fig. 543, would only allow to pass currents such as are shown in Fig. 547; that is, all the negative loops would practically be suppressed, and only those loops would persist in which the aluminium plate acted as a cathode. This

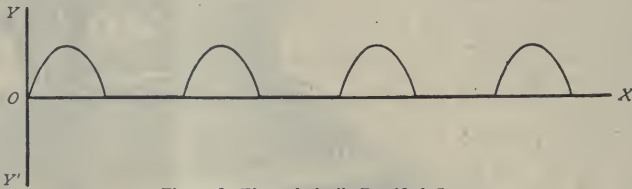

Fig. 547.—Electrolytically Rectified Current.

is the broad result, because a sufficient negative current would have to pass to set up the resisting film, and the starting of the positive loop would be slightly delayed whilst the film of oxide was being dissolved off.

Such a current, with its no-current intervals, would not be of much use for many purposes for which unidirectional currents are required, but by a combination of cells useful currents may be obtained. One of these combinations, designed by M. Leo Gratz, and known as an "electric valve," is shown diagrammatically in Fig. 548. Four cells, A, B, C, and D, are employed, and are arranged between the mains  $M_1 M_2$  as shown. In the diagram the cells are represented by a couple of lines, one short and the other long, the short line representing the aluminium electrode and the long one an electrode of iron or other suitable material. The cells being joined up as shown, the circuit in which unidirectional currents are required is placed between the points X and Y. When the main  $M_1$  is  $+$ <sup>ve</sup>, the current can flow through A and D, but not through C and B; as it can get from A to D through the connecting link X Y, it flows from  $M_1$  to  $M_2$  by the path  $M_1 A X Y D M_2$ , shown by the full arrows, a, a, a, flowing from X to Y through the circuit X Y. In the next half-period, when  $M_2$  is  $+$ <sup>ve</sup>

and  $M_1$  —<sup>ve</sup>, the current can get through B and C, but not through D and A; it therefore takes the path  $M_2$  B X Y C  $M_1$ , shown by the dotted arrows,  $b, b, b$ , and again flows from X to Y through the circuit X Y. In this latter

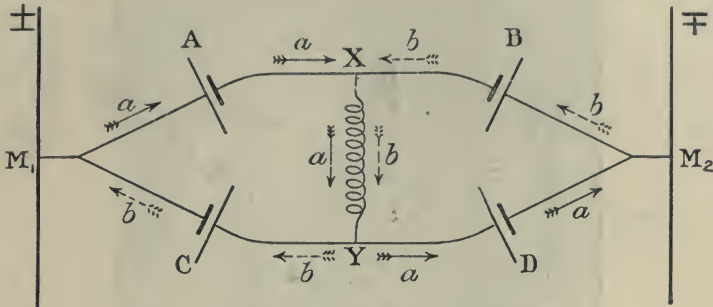

Fig. 548.—Connections for an Electrolytic or Electric "Valve."

circuit, therefore, the flow is from X to Y, whether  $M_1$  be +<sup>ve</sup> or —<sup>ve</sup>, and we have in it unidirectional currents as desired.

An actual "Nodon" valve of this type to carry a current of 5 amperes from X to Y is shown in Fig. 549. It transforms alternate to continuous currents without using any moving machinery, and the manufacturers claim that the capital outlay is much less, whilst the efficiency is good. The technical points involved, some of which are very interesting, will be dealt with in the technological section.

#### Mercury Vapour Rectifiers.

—There is another piece of apparatus, which can be so modified that the current can practically pass only in one direction. This is the mercury vapour arc lamp, with one of its electrodes made of solid material such as graphite. The lamp is described in a suc-

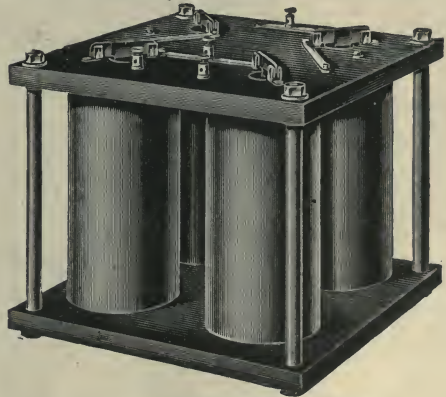

Fig. 549.—The "Nodon" Electric Valve.

ceeding chapter, and an early form of it, used as a rectifier, is shown in Fig. 550, while a diagram of the connections for working on a three-phase circuit and rectifying the alternate currents to a continuous current, is shown in Fig. 551. There are no fewer than four solid anodes, or +<sup>ve</sup> electrodes, marked  $E_1, E_2, E_3,$  and  $E_4$ , in Fig. 551, and seen at the top of the globe in Fig. 550. The cathode, or —<sup>ve</sup> electrode E is a mercury cup in the bottom part of the lamp. The anodes  $E_1, E_2,$  and  $E_3,$



are connected respectively to the three terminals of the secondaries of the star-connected three-phase transformer T supplied with current from the alternator A. The neutral point of the secondaries of the trans-

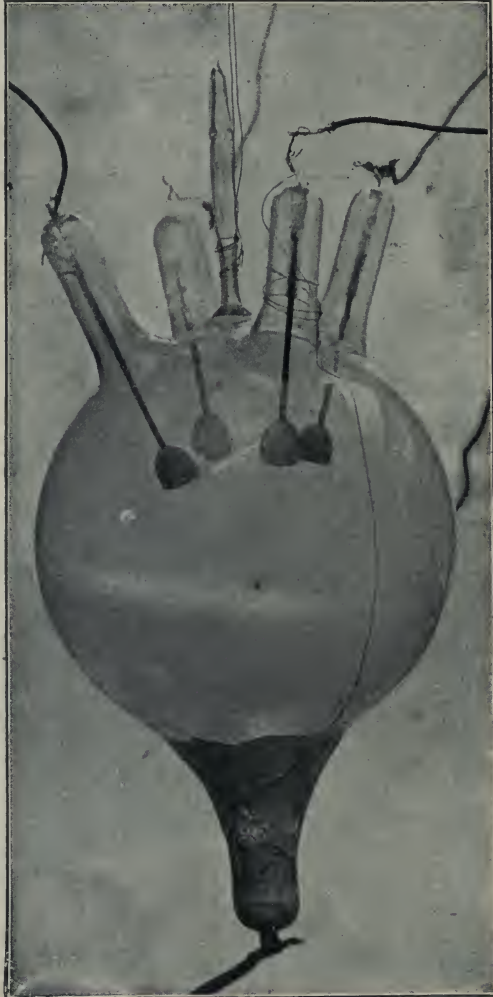

Fig. 550.—A Mercury Vapour Rectifier (early form).

former is connected to the main on the left from which continuous current energy is taken by the glow lamps, arc lamps, motor and storage battery shown diagrammatically in the lower part of Fig. 551, the other main being

connected to E. The fourth anode  $E_4$  and E are connected to a high voltage continuous current starting circuit, shown on the right of Fig. 551, which is necessary because, for reasons given later, it would be difficult, if not impossible, to start the rectifier from the alternate current side. When, now, any one of the anodes is  $+$ <sup>ve</sup> the current will flow through the rectifier from that terminal to E, but will not flow when the electrode becomes  $-$ <sup>ve</sup>. By switching on the continuous current first with  $E_4$   $+$ <sup>ve</sup> the action is started and the rectifier lights up as a mercury vapour arc lamp. If

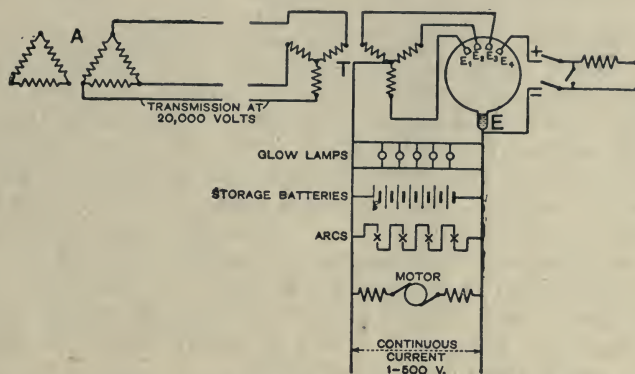

Fig. 551.—Diagram of connections for a three-phase "Mercury Vapour" Rectifier.

now the alternate current be switched on the electrodes  $E_1$ ,  $E_2$ , and  $E_3$  become successively and in rotation  $+$ <sup>ve</sup>, and before one ceases to be  $+$ <sup>ve</sup> another is ready to take up the running. Thus the flow through the rectifier is continuously towards E, which can never act as an anode, and when the action is properly started the continuous current high voltage circuit can be disconnected.

Various starting and other difficulties are encountered when it is attempted to work the rectifier on a single-phase circuit, but references to these and how they have been overcome belong more properly to the technological section.

## CHAPTER XV.

*ELECTRIC TRANSMISSION OF POWER.*

THE fundamental principles underlying the conversion of mechanical energy into the energy of electric currents of various kinds have now been dealt with, and a sufficient number of typical machines have been described to enable the reader to understand to some extent the methods adopted in applying those principles in detail. An electric power generating station, however, contains much more than the generators themselves. For, on the one hand, the mechanical power has to be applied to the generators through the medium of boilers and steam engines, or gas producers and gas engines, or water wheels (turbines, etc.), and, on the other hand, the production of electrical power has to be effectively controlled, and the power itself brought to suitable positions (switch-boards, etc.) within the station from which it can be directly utilised or transmitted to distant points where it may be required.

The tendency at the present time, and it is a tendency which is not likely to diminish, is to generate the electric power near the waterfall, coal mine, or other place where the energy to be utilised is most directly available. And, even when this is not done, it is getting more and more common, for numerous reasons which affect the cost of production either directly or indirectly, to place the generating station at some distance from the place or the centre of the district where the power is to be used ultimately. The problem of how to transmit power in bulk over longer or shorter distances is, therefore, becoming every day more and more important, and it is proposed to indicate here the main outlines of the electric solutions, and to postpone for the present the consideration of the more technical details connected with the design and working of generating stations.

## I.—FUNDAMENTAL PRINCIPLES.

It has been already pointed out in the preceding pages that the activity or power of a continuous electric current—that is, the rate at which it does work—is given by the equation—

$$W = EC \text{ watts,}$$

where  $c$  is the magnitude of the current in amperes and  $E$  the electromotive force in volts. This equation, which is true for the whole circuit,



is true for any part of it. Thus the work ( $w$ ) done per second by the current  $c$  between two points whose potential difference is  $v$  is given by the equation—

$$w = vC \text{ watts.}$$

Now, in all problems on the transmission of power the object is to make this quantity  $w$  as large as is required at the distant station; but if  $R$  be the resistance of the conductors used to convey the current to and from the distant station, we know by Joule's law that the heat generated per second in the conductors is  $c^2R$  watts, and therefore

$$w = W - c^2R.$$

In order, therefore, that  $w$  may be as large as possible for a given value of  $w$ , the term  $c^2R$  must be made as small as possible.

This can be done in two ways. First, by diminishing  $R$ , which, since the distance that the power has to be transmitted may be regarded as fixed by the conditions of the particular problem, can only be accomplished by increasing the cross-section of the conductors. This method, however, in most cases will involve heavy expenditure of capital, since the weight, and consequently the cost, of the copper or other conductors increases proportionately with the cross-section. A point is therefore reached sooner or later at which the interest on the extra capital invested in this additional copper, etc., overbalances the saving effected by diminishing the  $c^2R$  loss. Wherever large amounts of power or long distances are involved the economical point is soon passed. But the term  $c^2R$  can be much more satisfactorily minimised by diminishing  $c$ , the term  $w$  ( $= EC$ ) being at the same time kept constant by proportionately increasing  $E$ , the electromotive force available at the generating station. Thus if  $E$  be increased twenty-fold, and  $c$  diminished to one-twentieth of its former value,  $w$  will remain unaltered, but the power ( $c^2R$ ) wasted in heating the same conducting lines will be only one four-hundredth part of what it was previously; or if the object be to diminish the cost of laying the line rather than the waste heat, then in the second case a conductor of one four-hundredth of the cross-section, and therefore costing considerably less, will only waste the same amount of power as the much heavier conductor worked at the lower voltage. This case occurs where there is an excess of water-power available, as, for instance, in the problem of conveying the power of the Niagara Falls to New York, where the heat wasted during transmission would be to a great extent immaterial, but the cost of the conductors, if large currents were used, would be prohibitive.

But another difficulty now presents itself. If  $E$  is made large and  $c$  small, then since  $v = E - cR$ , it follows that  $v$ , the potential difference at the distant station, will also be large. If we intend to convert the whole of our electrical power ( $v c$ ) at once into mechanical power by means of motors, all we shall have to do will be to wind our motors

with fine wire and attend carefully to insulation, always provided that the voltage is not too high to make the cost of insulation too great or good insulation too difficult. But if the electrical power is to be used for general purposes, and particularly for supplying electrical energy to private houses, whether for lighting or otherwise, the use of a high P. D. under the control of the consumer is inadmissible, not only because of difficulties of insulation and leakage, but because in most countries legislative enactments absolutely prohibit it on account of the danger to life when such high potentials are handled by unskilled people. Unless, therefore, it is possible to alter the pressure at the distant end without much loss of energy, transmission at high pressure must be abandoned. Fortunately, however, the change can be economically accomplished by apparatus which we have already partly described (*see* pages 433 to 442) under the name of "**Transformers.**"

The term "Transformer," although most generally used at the present time to denote the modified form of induction coil already described at pages 433 to 442, and in which an alternate current is sent through the primary, is also applicable to, and is employed to denote, *any arrangement of apparatus or machinery by which the energy of a particular electric current is TRANSFORMED into the energy of another current differing from the first in magnitude, E. M. F., or kind.* The problem which presents itself is this: If  $T$  be the whole time in seconds during which the supply of electrical power is available, we have a certain quantity ( $v c T$ ) of electrical energy at our disposal, but one of the factors  $v$  is large, and therefore for various reasons unsuitable. The total energy, however, may be kept the same, and the difficulty be overcome, if we are able to vary the factors of the energy whilst their product is kept unchanged. This is the essential function of a transformer. The ideal perfect transformer would give us the equation—

$$v c T = v_1 c_1 T_1,$$

where  $v$ ,  $c$ , and  $T$  have the meanings already specified with respect to the energy supplied to the transformer, and  $v_1$ ,  $c_1$ , and  $T_1$  have corresponding meanings with respect to the energy given out by the transformer. As there is always a loss of energy in the transformation, no actual transformer satisfies the above equation,  $v_1 c_1 T_1$ , being always less than  $v c T$ .

**Transformers Available.**—Transformers, therefore, are essential in any scheme for the transmission of large quantities of energy electrically over long distances. In classifying those available it must be borne in mind that, owing to the difficulties of generating some kinds of electric currents at very high potentials, transformers may be required to raise the P. D. at the generating end as well as to drop it at the distant end. Thus we may want both "step-up" and "step-down" transformers. In the following summary of available transformers the term "primary current"

is used for the current before transformation, and the term "secondary current" for the current given out by the transformer:—

- (a) *For changing the voltage of continuous currents.*
- (i.) **Coupled Motor and Dynamo:** The primary current sets in motion an electric motor, which drives a dynamo mechanically by a belt or a coupling.
  - (ii.) **Motor Generator:** The motor and dynamo are combined in a single machine, which receives energy in its primary circuit, and gives it out at the changed voltage from its secondary circuit.
  - (iii.) **Secondary Batteries:** Used as voltage transformers by splitting the battery up into sections, joined in series for high voltages, and in parallel for low voltages.
- (b) *For changing the voltage or the phase of alternate currents.*
- (i.) **Static Transformers** or *Induction Coils*: These receive the primary current at one voltage and deliver the secondary current at the required voltage and phase.
- (c) *For changing from alternate to continuous currents (or vice versa).*
- (i.) **Coupled Motor and Dynamo** as in (a) (i.): The motor must be one adapted to work with the primary current, whether alternate or continuous, and the dynamo such as can generate the required currents.
  - (ii.) **Rotary Converters** (sometimes called *Rotaries*): These receive from the primary circuit an alternate (single or polyphase) or continuous current, as the case may be, and deliver to the secondary circuit the required continuous or alternate current.
- (d) *For changing from alternate to continuous currents only.*
- (i.) **Motor Converters:** These differ from rotaries in working in one direction only (though it is possible to reverse), and in there being no conducting connection between the two circuits.
  - (ii.) **Permutators:** In these only a set of brushes revolves, and the mass of the machine is stationary; they are irreversible.

Dynamos, secondary batteries, and static transformers have already been referred to; motors, motor generators, rotary converters, motor converters and permutators will be dealt with in the next chapter.

## II.—SYSTEMS OF TRANSMISSION.

In what follows it must be understood that a distinction is drawn between transmission and distribution. The former term, *transmission*,



will be used in those cases in which the generating station and the consumer or group of consumers are so far apart that the question of how the intervening distance is to be bridged is deemed worthy of separate consideration. If the distant consumers are numerous and lie close together, then, in the first instance, the power is usually transmitted from the generating station to a *sub-station* conveniently situated in their neighbourhood. For the delivery of the power to the consumers in the immediate neighbourhood of the generating station or the sub-station we shall use the term *distribution*. The limit at which distribution ends and transmission begins cannot be rigorously defined, for it depends not only on the distance but also on the amount of power to be handled. In fact the systems overlap, for the *feeders*, which are used in distributing systems, are modified transmitters. As a rule, for general distribution the limit is about a mile. An exception must, however, be made of the case of electric traction, to which the foregoing remarks do not strictly apply.

The preceding summary of the transformers available shows that there are no theoretical restrictions on the kind of current which may be used on the transmission line. Whatever method of generating the electric power is used, and whatever form of electric power may be generated and at whatever voltage, transformers are available for changing to any other voltage or form required for transmission to the distant consumers. And further, whatever may be the voltage or form of power on the transmission circuits on the one hand, or whatever may be the voltage or form of power required by the consumer on the other hand, transformers can be found capable of making the necessary changes. The solution in any given case therefore turns entirely upon details of capital cost, economy of working and maintenance, and difficulties of design and construction. Such details, as a rule, are highly technical, and we therefore only propose to illustrate the main principles here by reference to a few typical existing systems.

The considerations already set forth conclusively prove that for economical long distance transmission high voltages with a minimum number of conductors must be used. The classification of the available systems is therefore fairly simple and may be summarised as follows :

- (i.) Continuous current systems,
- (ii.) Single-phase alternate current systems,
- (iii.) Polyphase alternate current systems.

**Continuous Current Transmission.**—The employment of continuous currents for the transmission of electric energy over long distances offers many advantages as compared with the use of alternate currents, even when the latter are of the low periodicity of 25 periods per second. With continuous currents the changes of current strength occur slowly and to a certain extent gradually as compared with the rapid fluctuations of alternate currents, and the consequent changes in the electro-magnetic and electrostatic energy stored in the surrounding medium are correspondingly

slow and gradual. There is therefore an absence of those reactances on the transmitting circuit to which attention has already been called, and which are a serious source of trouble in practical work.

On the other hand, it has been found difficult to produce on a commercial scale continuous currents at anything like the voltages which have been attained in actual practice with alternate currents. There are in existence power transmission lines on which alternate currents at 50,000 volts are used, and still higher voltages have been tried. On the other hand, 1,000 to 2,000 volts mark the limits usually employed with continuous currents, and, bearing in mind the conditions already recited, the extending use of high-voltage alternate currents is easily understood. The difficulty in the case of continuous currents lies in the construction of a commutator which under working conditions will stand really high voltages, whether on the generating dynamo or on a motor-generator used as a "step-up" transformer. Continuous current high-voltage dynamos have been built for laboratory purposes by Crocker, Hurmuzescu, and others. Crocker's dynamo gave 0.3 ampere at 11,000 volts, and Hurmuzescu's 2 amperes, at 3,000 volts. On the Continent, however, M. Thury has installed several transmission schemes, the continuous currents for which have been generated by dynamos giving pressure up to 3,500 volts each, and which being placed in series have raised the transmission pressure to 25,000 volts and over.

For the above reasons continuous current transmission over long distances is not yet much used, though it is largely employed for short distances. The following method used some years ago by the Chelsea Electricity Supply Company for transmitting power from its generating station to its sub-stations is described as an illustration of the principles involved, and also as being of historical interest:—

The dynamos *D* (Fig. 552) generated a current at a pressure of 500 volts, which was used to charge secondary batteries at sub-stations. Each battery was in two halves, and each half was again divided into four sections of 54 cells each. When being charged by the current from the central station the four sections of one half of the battery were joined up in series. When the sections were fully charged they were automatically switched out of the charging circuits, placed in parallel with one another, and connected to the distributing mains of the district supplied by the sub-station. The four sections of the other half of the battery, which had meanwhile been supplying current to the distributing mains, were, when discharged, taken off those mains, placed in series with one another, and switched into the dynamo circuit. The connections with one half of the battery being charged and the other being discharged are shown in Fig. 552, in which *D*, *D*, *D* are the dynamos, *A*, *A*, *A* the sections of the battery which are being charged in series (only three are shown), and *B*, *B*, *B* are the sections in parallel which are supplying current to the distributing mains *L*, *L*, *L*.

c, c, c are reversed cells in the discharging circuits which are automatically connected up as shown, so as to keep the discharging P. D. constant.

When both halves of the battery were charged the dynamos were stopped and all the cells were put on to the distributing mains. If the demand

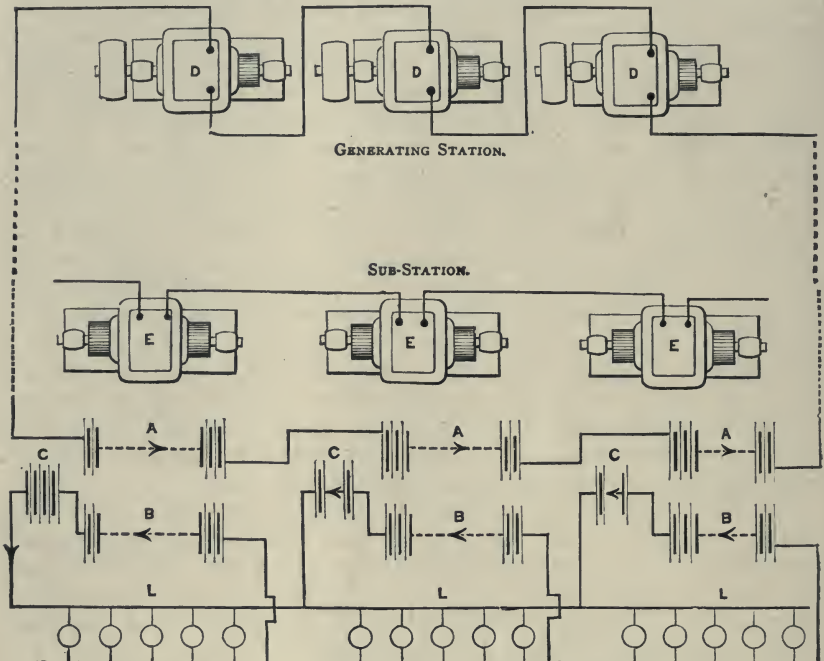

Fig. 552.—Continuous Current Transmission with Secondary Batteries as Transformers.

was greater than the cells could supply, the dynamos were again started and current supplied to the motor generators E, E, E, whose secondary circuits then supplied a 100-volt current to the distributing mains. The whole of the somewhat complicated changes of connections necessary in this system were automatically accomplished by a set of ingenious switches designed by Mr. F. King.

**Single-phase Alternate Current Transmission.**—The general connections, leaving out all details of switch-boards, regulating and safety devices, etc., of a modern high pressure transmission plant with single-phase alternate currents are shown in Fig. 553. In this diagram the generator G is assumed to be delivering single-phase currents at a pressure of 5,000 volts, though much higher pressures have been directly generated. The 5,000-volt current is led to the static transformer or bank of transformers  $T_1$ , which raises the pressure to 30,000 volts, at which the energy



is delivered to the transmission lines  $LL$ ,  $L'L'$ , by which it is conveyed to the distant transformer house  $T_1$ . Here there are "step-down" transformers which reduce the pressure back again to 5,000 volts, at which it is delivered to one or more sub-stations in the immediate neighbourhood of the consumers, where the pressure is again reduced by static transformers to, say, 400 to 500 volts, at which the energy is delivered either to rotary converters to be transformed into continuous current energy, or direct to the distributing mains for ordinary single-phase alternate current distribution.

It is interesting to note both the resemblances and the differences between this diagram and the diagram (Fig. 427) on page 462 for the electric transmission of speech. In both diagrams induction coils are used as "step-up" transformers to obtain a high voltage for long distance transmission. In the telephonic case, however, the amount of energy dealt with is almost infinitely small, and questions of economy

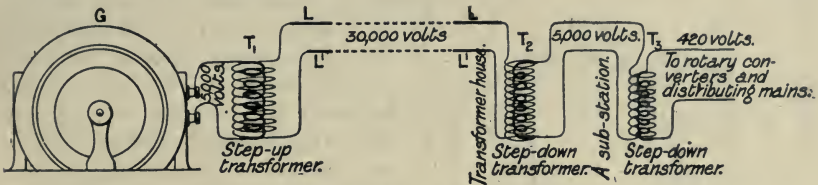

Fig. 553.—Diagram of Single-Phase Transmission.

of energy do not arise, other considerations being of far greater importance. In the power case questions of economy dominate the problem; hence note the careful specification of the voltages required, a specification which is quite absent from the previous problem.

Some years ago, in 1892, the pioneer work in long distance transmission at high voltage with single-phase currents was being done by Mr. Ferranti at the Deptford Station of the London Electric Supply Corporation. It was here that a pressure of 10,000 volts was used for the first time in 1891 on a single-phase transmission line, and a few details of the transmission at that time will be of historical interest. Two small alternators, afterwards replaced by larger machines which generated current at 10,000 volts, gave each a current of 196 amperes at 2,400 volts, which was transformed "up" to a less current at 10,000 volts. The 10,000 volt current was then transmitted to sub-stations in London, where large transformers reduced the pressure to 2,400 volts, at which pressure current was delivered to a network of high-pressure mains in the neighbourhood of the sub-station. Finally, this current was again transformed to a 100-volt current by transformers placed on the consumer's premises, or several consumers close to one another were supplied from banked transformers. The distance of the farthest glow

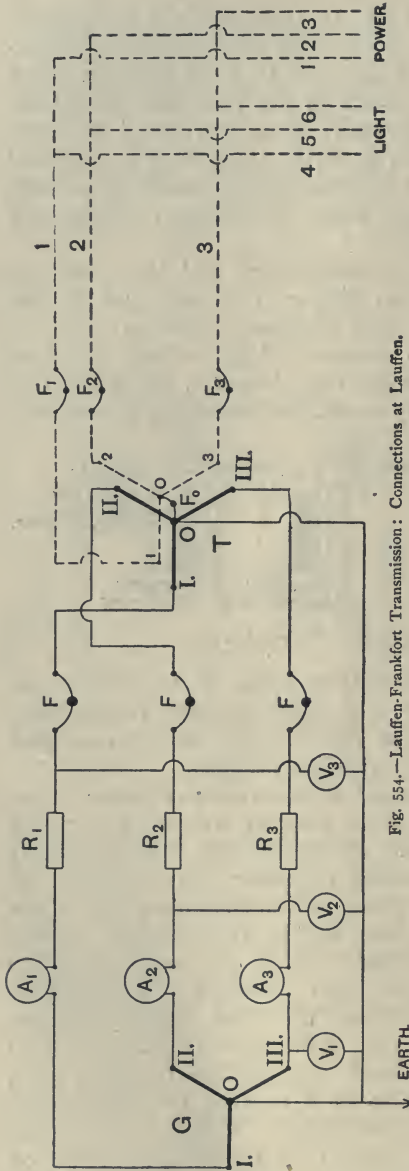

Fig. 554.—Lauffen-Frankfort Transmission: Connections at Lauffen.

lamp lighted from Deptford was  $9\frac{1}{2}$  miles. Important electrical and mechanical details in connection with this and similar stations will be referred to later.

**Polyphase Alternate Current Transmission.**—The fundamental details of this method of transmission will be best understood from the description of an historical example, namely, the three-phase transmission to the Frankfort Electrical Exhibition in 1891 of energy derived from the falls of the Rhine at Lauffen, a distance of 110 miles. At Lauffen a Brown three-phase generator G (Fig. 554), driven by a 300 horse-power turbine, supplied current to three transformers, where the pressure was increased in the ratio of 1 to 160 before the current was passed on to the line wires. The arrangement of the circuits at the generating end is shown diagrammatically in Fig. 554, due to Mr. Gisbert Kapp. Here G represents the generator with the "star" (see page 549) connected windings o I, o II, o III.; the three conductors from the generator were each led through an ammeter A, a relay-magnet R, and a fuse F, to three transformer coils at T. The other ends of the low-pressure coils of the transformers T had a common junction, o, which was joined to earth and the common junction o of the coils of the generator G. A voltmeter, v, was placed between each low-pressure conductor and the earth. The secondary coils 1, 2, 3, of the transformers are represented by dotted lines; three of their terminals had a

common junction o, which was connected to the common junction of the low-pressure coils through a fuse F<sub>0</sub>. The other high-pressure terminals

were joined to the transmitting wires through fuses  $F_1, F_2, F_3$ . These last wires consisted of hard-drawn copper 0.16 inch in diameter, supported on oil-insulators in the same way as an ordinary telegraph line. The P. D. between any line and earth was at first about 8,000 volts, and between any two-line wires nearly 14,000 volts; but in the final experiments this latter P. D. was raised to 30,000 volts. The function of the relays  $R_1, R_2, R_3$  was to cut off the field-magnet exciting current from the generator if the current in any branch of the low-pressure circuit either exceeded a certain maximum or fell below a certain minimum. The earthing of the common junctions of the generator and of the high- and low-pressure coils of the transformers makes the earth the electrical centre of the system, and prevents any serious accident should one of the line wires break and fall to the ground.

The connections for the power substation at the Frankfort end are shown in Fig. 555. The line wires 1, 2, 3, were connected to the high-pressure coils of three transformers, whose low-pressure coils were joined to the fixed coils (the "stator") of a three-phase motor. This motor is represented diagrammatically as consisting of two three-pointed "stars" with their common junctions connected at  $o$ . The two sets of "star" windings do not, of course, retain the same relative position when the motor is working, as otherwise the moving coils would not cut any magnetic lines, and thus neither E. M. F. nor current would be set up in them. It will be explained later that the moving coils (the "rotor") of such a motor are only traversed by induced currents. The free ends of the moving coils, instead of being directly connected, were brought to three adjustable liquid resistances,  $B_1, B_2,$  and  $B_3$ , consisting of iron vessels containing alkaline solutions,

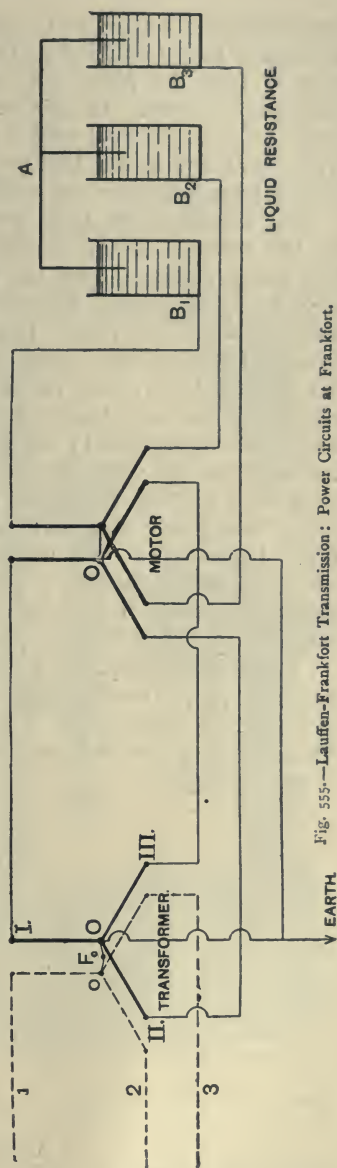

Fig. 555.—Lauffen-Frankfort Transmission: Power Circuits at Frankfort.



into which the iron plates A could be lowered. At starting the iron plates are drawn nearly out, but as the armature gets up speed and its induced E. M. F. falls, the plates are lowered until at full speed the rotor coils are short-circuited. In this way the great rush of current which would occur in short-circuited coils if the rotor were standing still was avoided. The motor had at full load an output of about 100 horse-power, and was designed specially for these experiments by Herr von Dolivo-Dobrowolsky.

The results of the trials were very satisfactory. The power delivered by the turbines to the dynamos at Lauffen was measured, and likewise the power obtained from the motor at Frankfort. In one experiment 113 horse-power was delivered to the dynamos, and 81 horse-power obtained from the motor 110 miles away, the transmitting conductors being no stouter than ordinary telegraph wires. These figures show a net efficiency of about 72 per cent. In some other experiments the electric power was used for lighting, and a much larger amount of power was transmitted; for this purpose the line wires 4, 5, 6 were connected to the high-pressure coils of transformers, whose low-pressure coils were directly connected to the lamp circuits. In one case, when 197.4 horse-power was delivered by the turbines at Lauffen, as much as 145.8 horse-power was utilised in the lamps at Frankfort, the net efficiency being thus 73.9 per cent. These figures showed that the electric transmission of large powers over long distances was not only theoretically but practically possible.

The above descriptions merely give the outlines, by examples which are now historical, of the three solutions, referred to on page 576, of the problem of the electric transmission of large quantities of energy over long distances. The numerous technical details and appliances will be dealt with later as far as space permits.

## CHAPTER XVI.

## ELECTRIC MOTORS.

ONE of the most useful of the mysterious properties of the electric current is that we are able to transform the electrical energy which it carries into mechanical energy, available for all the multifarious work to which such energy can be put. Moreover, in many cases it is possible to effect the transformation at the very place where the mechanical energy is required for useful work, and thus full advantage can be taken of the great flexibility and convenience of electric conductors as transmitters of energy. The machines by which the transformation is effected are known as **electric motors**, which may be defined as *machines for converting energy in the form of electric currents into energy in the form of mechanical power by magneto-electric induction; the operation being, in general, that of setting conductors to rotate in a magnetic field.*

These machines already play a very important part in the modern applications of electricity, and their relative importance is likely to increase rather than diminish in the future. Apart, therefore, from the fascinating physical laws which underlie their action and their historical interest, they are deserving of careful attention on other grounds.

## I.—HISTORICAL NOTES.

**Early Electric Motors.**—It would seem that the first electric motors (shown in Figs. 556 and 557) were constructed by Salvatore dal Negro, Professor at the University of Padua, in 1830, and therefore before Faraday's

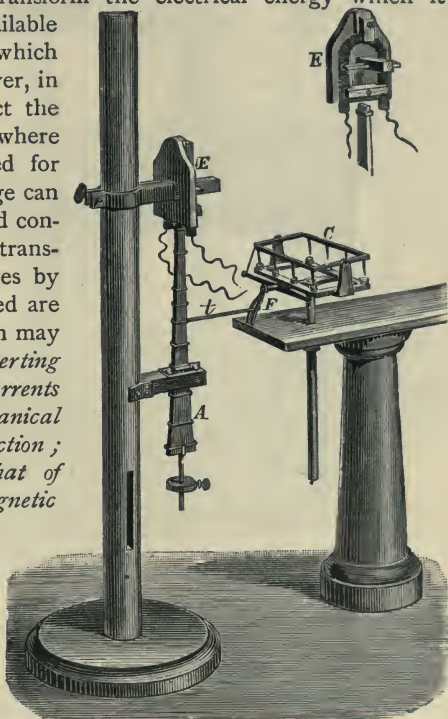

Fig. 556.—Dal Negro's first Electric Motor.

discovery of magneto-electric induction. The steel magnet *A* (Fig. 556) is mounted to oscillate about an axis, in such a way that its upper end moves between the poles of the electro-magnet *E* (drawn separately). When a current flows through the coils of the electro-magnet, the upper end of the permanent magnet *A* will move so that it approaches the dissimilar, and moves away from the similar pole of the electro-magnet. If the poles of the electro-magnet are made to change constantly, the magnet *A* will be made to oscillate. The change of direction of the current is brought about by the commutator *C*, which is set in motion

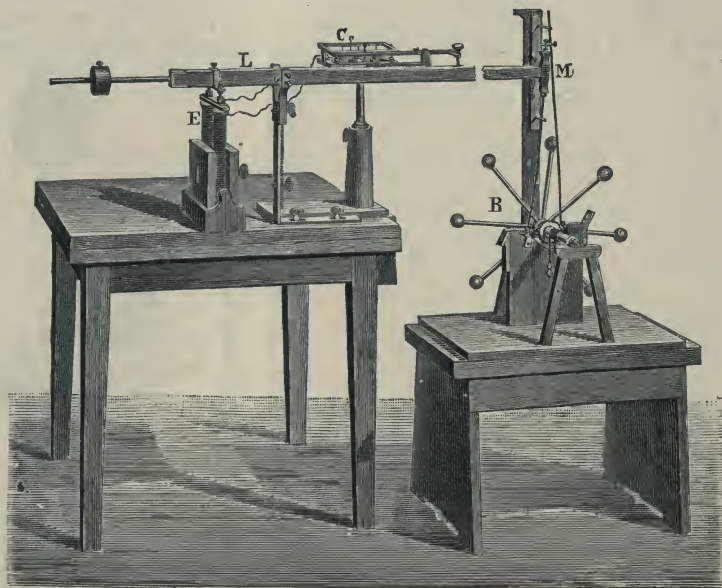

Fig. 557.—Dal Negro's second Electric Motor.

by the magnet *A*, by means of the rod *t* and forked piece *F*. The commutator is inserted in the same circuit as the electro-magnet, and reverses the direction of current exactly at the moment when the permanent magnet has approached the one or the other pole of the electro-magnet.

By means of the second apparatus (shown in Fig. 557) a continuous rotation is produced. Here the electro-magnet *E* influences an armature fastened to the horizontal lever *L*, by means of which the motion of a commutator *C* is also brought about. From the projection *M* of the lever a rod catches in the teeth of a wheel, keeping it in motion. To make this motion more uniform, pieces of wood or spokes which have balls at their ends are fastened radially upon the axis of the toothed wheel.

Jacobi, the inventor of electro-deposition, described in 1834 the con-



struction of an electro-motor (Fig. 558), which, after undergoing several alterations, was employed for propelling a vessel on the Neva. The apparatus consists of two series of horse-shoe electro-magnets fastened upon two supports; between these supports, upon a horizontal axis, is a six-armed wheel, each of whose arms carries a couple of straight magnets parallel to the axle. Upon the same axle is fastened a commutator of four discs, which changes the direction of the current in the coils of the electro-magnets at that moment when the straight electro-magnets are opposite the poles of the horse-shoe magnets. If the straight magnets are between two succeeding horse-shoe magnets, one of the latter influences the intermediate straight magnet with a repelling, the other with an attracting, force. When, therefore, the terminals of the motor are connected with a battery, continued rotation is obtained by means of the moving magnets and the spur wheel. Du Moncel and Gerdard (in *L'Électricité comme Force Motrice*) describe the following experiments made with this motor for propelling a vessel on the Neva. For the first experiment a battery of 320 Daniell cells was used, in which each of the copper and zinc plates had a surface of thirty-five square inches. With this battery the vessel moved with a velocity of

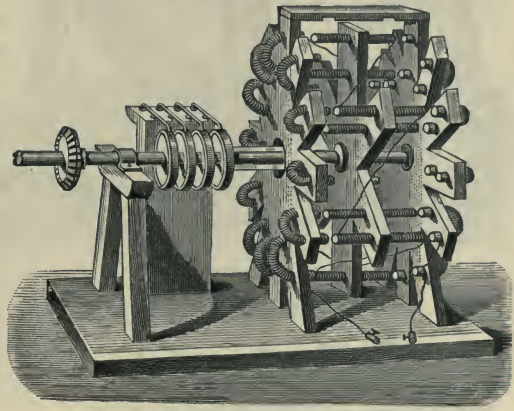

Fig. 558.—Jacobi's Electric Motor.

1.4 miles per hour. For experiments in 1839 Jacobi used a battery consisting of 128 Grove cells of the same surface area of plates. With this he obtained a velocity of 2.6 miles per hour. The vessel itself measured 27.5 feet by 7.5 feet, and carried twelve persons. These experiments are said to have cost about £2,400, and were paid for by the Emperor Nicholas.

The motor constructed by Elias in 1842 resembles the ring subsequently constructed by Pacinotti in appearance, and consists (Fig. 559) of two concentrically arranged iron rings,  $F$  and  $T$ , each having six groups of coils. The outer ring is fixed, and is carried by the supports  $c c'$ . By means of the six layers of wire, which are wound alternately in opposite directions, the whole ring is divided into six electro-magnets, the poles of which  $A A'$  are alternately north and south seeking, and are energised by currents supplied to the wires  $g$  and  $g'$ . The inner ring  $T$ , which can rotate round a horizontal axis supported by  $P P'$ , is constructed in a similar manner, and has also six poles  $a a'$ . The commutator  $c$  is fastened upon

the same axle, and consists of six metal strips at equal distances from each other, and connected alternately to the wires  $f$  and  $f'$ . Over this

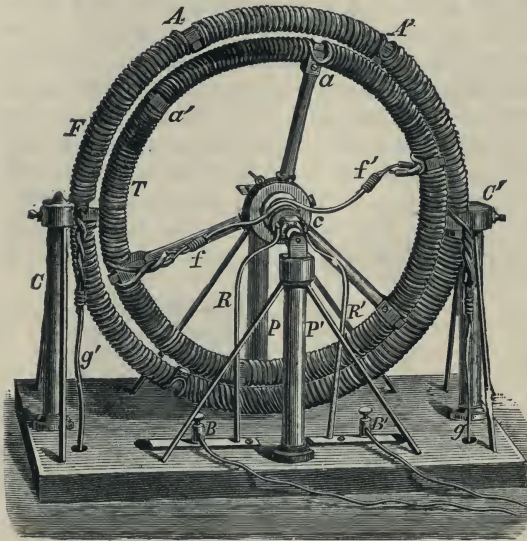

Fig. 559.—Elias's Electric Motor.

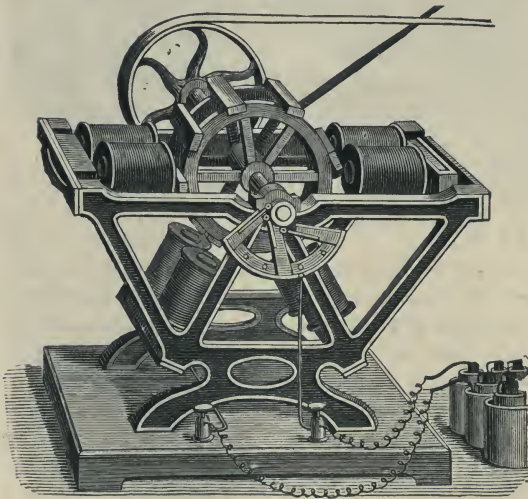

Fig. 560.—Froment's Electric Motor.

commutator slide the springs  $R R'$ , which are connected with the clamps  $B B'$ . A battery being connected to  $B$  and  $B'$ , the current flows from  $f$  to  $f'$ , or from  $f'$  to  $f$ , according to the position of the commutator. Thus the direction of the current in the spirals of the inner ring is constantly changing, and this causes a corresponding change of the poles  $a a'$ , and a continuous rotation of the ring  $T$ . If, for instance,  $A'$  is a north pole,  $a$  has to be a south pole, and is then attracted by  $A'$  and repelled by  $A$ . If the south pole  $a$  has now arrived at the north pole  $A'$ , the south pole  $a$  is immediately converted into a north pole, because the springs  $R R'$  have also arrived at the next metal strips, causing a reversal of the current in the coils of the movable ring. The north pole  $a$  is now repelled by the unchanged north pole  $A'$ , and attracted by the south pole  $C'$ , hence the inner ring continues its rotation in the same direction.

Froment, during the years 1844 to 1862, constructed several motors,

to which he gave different shapes. We shall describe only one of these; and for further information refer to Th. du Moncel and Gerdal's work,



*L'Électricité comme Force Motrice.* A motor constructed in 1845 is shown in Fig. 560. Four double electro-magnets are fastened upon a frame, as shown. A wheel rotates between the poles of these electro-magnets, and carries soft iron bars, which are fastened upon its circumference and serve as armatures for the magnets. The attraction which these magnets exert upon the armatures brings about a continuous rotation. The current from a battery is first conveyed to a commutator, which supplies the several electro-magnets with continuous currents periodically interrupted. The commutator consists of a series of contacts fastened to the shaft of the wheel, over which slide contact wheels or buttons pressed by springs. Thus it happens that those two electro-magnets are supplied with currents which are being approached by the iron armatures of the wheel. This motor is still used for toys or demonstrations in physical laboratories, and when supplied with alternate currents is useful for getting synchronous rotation.

Various motors were constructed from time to time, in which the reciprocating motion of an iron plunger inside a solenoid was made to transmit motion to machines in much the same way that the motion of a piston in a cylinder is utilised in steam engines. Of these, Hjorth's and Page's were described in the first edition of this book. But Pacinotti's motor with a ring-wound armature, invented in 1860, was a great advance on all these. Eleven years before the invention of the Gramme dynamo, the ring armature wound upon a core with projecting teeth was used in this electric motor. So important was this step in the history, not only of motors, but of dynamos, that we give here a translation of the original paper in Italian, by Dr. Pacinotti. Fig. 561 is taken from *La Lumière Électrique*, and represents a model machine exhibited in Paris in 1881.

*Description of a Small Electro-magnetic Machine by Dr. Antonio, Pacinotti.*

In 1860 I had occasion to construct, for the Museum of Technological Physics of the University of Pisa, a small model of an electro-magnetic machine devised by me, an account of which I now decide to publish, especially in order to make known an electro-magnet of a particular kind employed in the construction of the said machine, which seems to me to be adapted to give greater regularity and steadiness of action in such electro-magnetic machines; and is of a form suitable for collecting the sum of the currents induced in a magneto-electric machine.

In ordinary electro-magnets, even when a commutator is adapted thereto, the magnetism always appears in the same positions; whilst with the commutator which is united to the electro-magnet that I describe, the poles can be made to move in the iron. The form of the iron of such electro-magnet is that of a circular ring. In order to easily understand the movement and the mode of action of the magnetising current, let us suppose there be wound upon our ring of iron a copper wire covered with silk, and when the first spiral is finished, instead of continuing the helix by going over that already constructed, let the wire be closed by soldering together the two ends that



come near each other. In this manner we shall have covered the iron ring with a closed insulated spiral directed entirely in one way. Now if we connect the poles of an electric battery with opposite points of the wire of this helix on one side and on the other of the ring, the direction the current takes will be such that the iron will become magnetised, presenting the magnetic poles at the places where the conducting wires are applied. The direct line that unites these poles may be called the magnetic axis. By changing the points in communication with the battery we may give any position to this magnetic axis transversal to the figure or ring of iron of the electro-magnet.

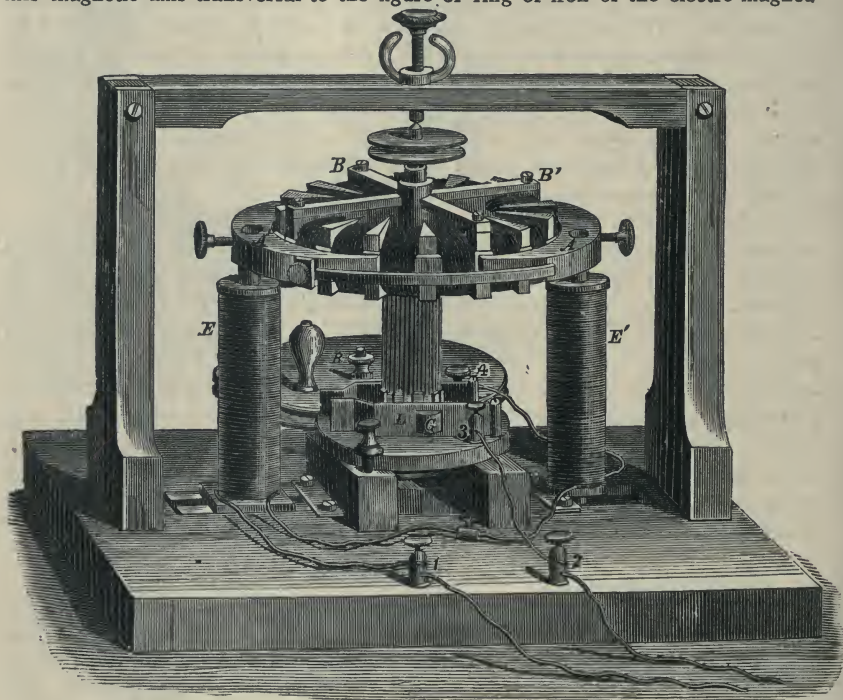

Fig. 561.—Pacinotti's Machine.

I, therefore, like to consider such a ring as two transversal semicircular electro-magnets placed in juxtaposition, and having the poles of the same name in contiguity. In order to construct on such a principle the electro-magnet with which I mounted the small electro-magnetic machine, I took a turned iron ring, having the shape of a toothed wheel, with sixteen equal indentations. This ring was supported by four brass radii,  $B$   $B'$ , which unite it to the axis of the machine. On each tooth of the ring I placed a small triangular prism made of wood, and so I left hollow grooves, within which I could wind copper wire covered with silk. I have succeeded in placing between the teeth of this iron wheel a number of helices or electro-dynamic coils well insulated. In all these the wire is wound in the same direction, and each of them has nine

spirals. Any two consecutive bobbins are separated from each other by an iron tooth of the wheel, and by the little piece or triangular prism of wood. Passing from one bobbin to construct the following one, I have left free a tassel or fork of copper wire, fixing it to the piece of wood which separates the two bobbins. On the axis on which the wheel so constructed rotates I have brought all the tassels that with one end form the termination of one bobbin, and with the other the beginning of the next one, making them pass through convenient holes in a wooden collar centred on the same axis.

This commutator consists of a small cylinder of wood, with two rows of grooves around the cylindrical surface, in which sixteen copper pieces are inlaid, eight on the upper portion and as many below; the first alternating with the second, all being concentric with the wooden cylinder, and a little projecting and alternating with the wood. Each of these small pieces of copper is soldered to the corresponding tassel joined between the two bobbins, so that all the bobbins communicate with each other, each being united to the next by a conductor, of which one of the small pieces of copper of the commutator itself makes part. Putting two of these in communication with the poles of a battery by means of two small metallic wheels, the current will divide and will run through the helix on one side and the other of the points, whence the tassels start, united to the two small communicating pieces, and the magnetic poles will appear in the iron of the wheel. Upon such poles the poles of a fixed electro-magnet  $E E'$  act and determine the rotation of the transversal electro-magnet around its axis. Even when the electro-magnet is in motion, the poles are always produced in the same positions, which correspond to the communications with the battery.

This fixed electro-magnet, as appears by Fig. 561, is composed of two iron cylinders  $E E'$ , joined together by an iron cross-piece, to which one is permanently screwed, and the other is fastened by a screw, placed underneath, which allows it to run along a groove, in order to make the poles of the cylinders  $E E'$  approach or recede from the teeth of the wheel. The current of the battery entering from the conducting wire 2 passes through a wire to the binding screw 3, and from that to the little wheel  $G$ , circulates around all the bobbins of the wheel, and returns through the connection 4, which makes it pass through another copper wire to the helix, which surrounds the cylinder  $E'$ . From this, coming out again, it passes to the helix of the cylinder  $E$ , and is conveyed through another copper wire to the second conducting wire 1. I have found it very advantageous to add to the two poles of the fixed electro-magnet two soft iron armatures  $A, A'$ , each of which embraces for more than one-third of the circle the wheel that constitutes the transversal electro-magnet, placing them very near to the teeth of the same, and tying them together with copper guides.

The machine works when the current passes only through the circular electro-magnet, but it has much less strength than when the current passes also through the fixed electro-magnet.

The reasons that induced me to construct the small electro-magnetic machine upon the system described were the following:—

(1) In the method adopted the current never ceases to circulate in the helices, and the machine does not move by a series of impulsions that succeed each other more or less rapidly, but by a union of forces that act continuously.

(2) The circular construction of the revolving magnet contributes, together with the preceding method of successive magnetisations, to give regularity to the movement and the least expenditure of actual force in shock or friction.

(3) In it nothing is sought but that the magnetisation and demagnetisation of the iron of the electro-magnet be accomplished instantaneously, to which are opposed both the extra currents and the coercive force, of which the iron can never completely get rid; but it is only required that every portion of the iron of the transversal electro-magnet, subjected always to the convenient electro-dynamic forces, pass successively through the various degrees of magnetisation.

(4) The external armatures of the fixed electro-magnet continuing to act upon the teeth of the electric wheel, and embracing very many of them, do not abandon its (the wheel's) action while magnetism remains in them. The sparks are increased in number, but much decreased in intensity, inasmuch as there are no strong outside currents on the opening of the circuit, which may always be kept closed, and it is only when the machine acts that an induced current continues directed in a contrary course from the current of the battery.

The main principles of the modern continuous current electric motor are embodied in this machine of Pacinotti's, notwithstanding its obvious and great defects when looked at in the light of subsequent developments. We therefore conclude our historical notes here.

#### II.—CONTINUOUS CURRENT MOTORS.

The chief defects of the older machines described above, considered as motors, were due to intermittent impulses, generation of heat by means of eddy currents, and bad mechanical arrangements. In modern machines the impulses follow one another so rapidly as to be practically continuous, whilst all parts subjected to reversals of magnetisation are carefully laminated, and thus heating by eddy currents is reduced to a minimum. The parts that are to influence each other are also better arranged to produce the maximum effect obtainable, and the various principles underlying the good mechanical design of running machinery are carefully observed.

**Reversibility of Continuous Current Dynamos.**—If the armature of a continuous current dynamo machine is made to rotate, as does the ring of a Gramme machine, currents are produced in the coils of the ring which may be utilised for the excitation of the electro-magnets, and for other purposes in an external circuit. The machine, therefore, converts mechanical work into electric energy. If the reverse process be now adopted, *i.e.* if the poles of such a machine are connected with conductors from a generator of continuous currents, the currents of the latter will have to pass through the coils of the machine, the electro-magnets of it will be excited, and will influence the coils of the armature. The armature will then begin to rotate, and will continue to do so as long as the currents from the source of electricity flow through the coils of the machine. This motion of the armature can be transmitted



by belting, etc., to any machine which is required to do mechanical work. In this case the electric energy is converted into mechanical work, or the exact reverse of the first case. This property of dynamo-electric machines to convert mechanical work into electric energy and electric energy into mechanical work, is expressed by saying that "the dynamo is a reversible machine."

It is, however, quite worth the trouble to examine carefully how these results necessarily follow from the principles we have already explained. For this purpose we reproduce (Fig. 562) a diagram previously used (*see* page 505) to explain a different point. The figure shows the direction in which the currents flow in the wires of the armature of a bi-polar continuous current dynamo when the armature rotates in a clockwise direction.

The currents in the section *a d c* on the right are represented as flowing from the observer, and those in the section *c b a* on the left as flowing towards the observer. Now in order to drive the conductors carrying these currents through the bi-polar magnetic field of the machine, we have seen that a torque, or turning moment, which in large machines requires a powerful engine to produce it, has to be applied to the shaft of the dynamo. It therefore

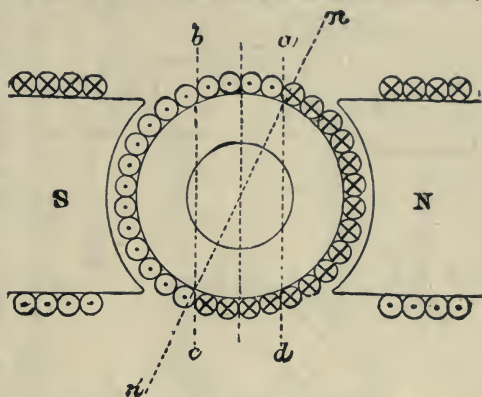

Fig. 562.—Motor Action on Armature Currents.

follows that the armature, in order that its rotation may be maintained, has to overcome resisting forces which, as we have seen, act upon the conductors whilst passing through the magnetic field. All this is in accordance with Lenz's law so often referred to in the preceding pages.

Now let us suppose that, whilst the magnetism of the field is still maintained as shown in the diagram, we pass currents of the same magnitude and direction, obtained from some external source, through the wires of the *stationary* armature. All the conditions which called into existence the forces just referred to are now present. We have the magnetic field and the current carrying conductors lying in it in exactly the same positions as previously. The same forces will, therefore, again be produced acting in the same direction as before, which was such as to *resist* the rotation of the armature in a clockwise direction. They will, therefore, *tend to rotate* the armature in a *counter-clockwise* direction, and the armature will rotate in that direction provided any other forces tending to resist its rotation are not too great. Up to a certain limit,

therefore, work can be done by the armature against external forces which tend to prevent its rotation.

The fact that a current-carrying conductor placed across the lines of a magnetic field is subjected to a mechanical force tending to pull it sideways may be tested by a simple experiment. Let *N*, *s* (Fig. 563) be

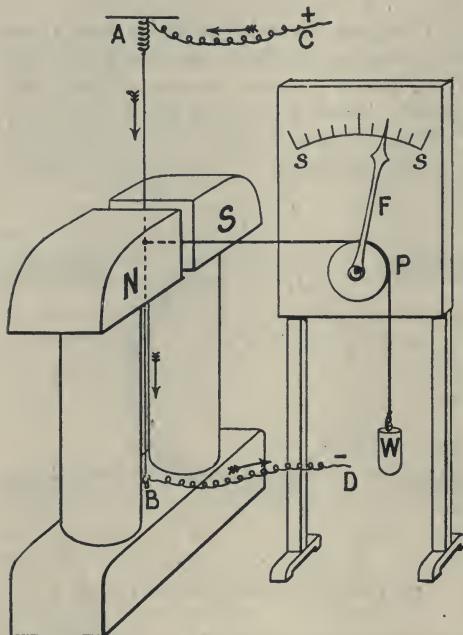

Fig. 563.—Force Exerted on a Current-Carrying Conductor placed across a Magnetic Field.

the pole pieces of an ordinary electro-magnet, having their faces flat and with only a narrow air-gap between. In this gap is stretched the vertical copper wire *AB*, kept taut by a strong spring at *A*; current can be passed into the wire from the leads *C* and *D*. Attached to the wire in the middle of the gap is a horizontal cord passing over a pulley *P* and kept taut by a weight *w*; the pulley carries a pointer *F* which moves in front of a scale *s s*. If the electro-magnet be now excited and have the polarity indicated, it will be found that on passing a strong current *down* the wire the index *F* moves towards the *right*, showing a similar movement in the wire. The index returns to zero when the current in the wire ceases, and moves in the opposite direction if the

current in the wire be reversed and sent *up* instead of down. The first case given (current downwards) is that depicted diagrammatically in Fig. 447, the observer being supposed to stand on the left-hand side of the magnet (Fig. 563) and facing it. The experiment can be further varied by reversing the magnetising current of the electro-magnet.

Another and very important point arises in the experiment with the dynamo (Fig. 562). We have now the armature rotating in an opposite direction in the same magnetic field as before. In accordance with the principles of magneto-electric induction *E.M.F.*'s must be set up in the copper conductors, and these *E.M.F.*'s must be in the opposite direction to those generated when the machine was running round the other way. In the latter case the *E.M.F.*'s were in the same direction as the current—in fact, they were the *E.M.F.*'s necessary to produce the current. In

the present case the current is still in the old direction, and therefore the reversed E.M.F. must be a **back E.M.F.** which tends to diminish the effective pressure in the circuit in which the current is flowing, and actually does reduce the magnitude of the current.

We return to a point previously referred to. It has been asserted that no energy can be taken from an electric current (other than the  $C^2R$  waste heat) unless the process by which the energy is transformed generates a back E.M.F. in the electric circuit. We have here a most important illustration of this principle.

The fact that the current is so cut down by a back E.M.F. may be tested experimentally. Let two dynamos be connected with each other, as shown in Fig. 564, the current being led through the armature of

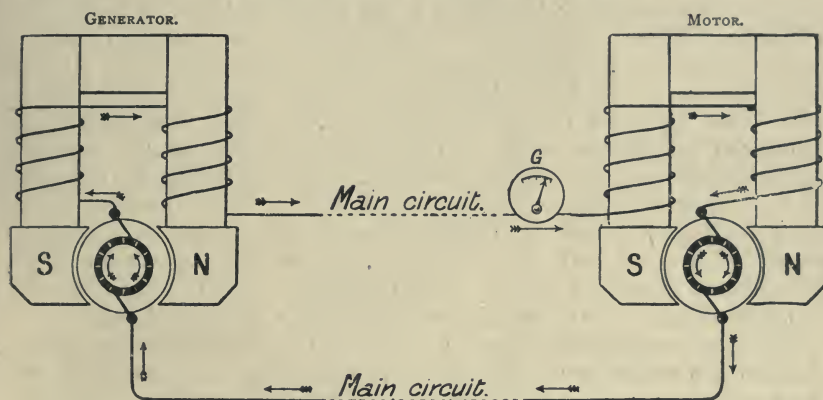

Fig. 564.—Experiment on the Back E. M. F. of a Motor.

the machine marked "motor" in the direction opposite to that in which it passes through the generator. The motor will then tend to rotate in the same direction as the generator. Let the generator be maintained at a speed of, say, 1,000 revolutions per minute, and the speed of the motor be allowed to increase gradually. If a galvanometer *G* be included in the circuit of the two machines, the needle will show a rapid decrease of current in the circuit as soon as the motor begins to rotate. The back E.M.F. produced will, we know, increase with the speed of the motor. The needle of the galvanometer, therefore, indicates a steady diminution of current, as long as the speed of the second machine, which we suppose has no work to do except to overcome friction, etc., continues to increase. The speed of the latter will, however, only increase as long as the E.M.F. of the generator is greater than the opposing E.M.F. of the motor. The machines being similar in construction and equal in size, it follows that when the speed of the



second machine has increased until it is the same as that of the generator, the E.M.F.'s will also be equal, the current will become zero, and the needle will not be deflected. This condition cannot be reached practically, because of the friction of the second machine.

Let us now consider the case in which the motor has to do work. The extreme case is that in which the armature of the second machine is held fast, *i.e.* forcibly prevented from rotating. In this case the second machine cannot produce an opposing E.M.F., but acts as a simple circuit of small resistance for the generator, the current of which will increase rapidly to its maximum value. What then becomes of the expended energy? It is converted into heat, and the experiment can only last for a very short time without damaging both machines. Suppose now the motor is allowed to do work, say to lift a load. The generator receives energy from the steam-engine, and furnishes electric currents; the motor receives electric currents, and does work. If the work the motor has to do is only very slight, its speed will not be very much less than that of the generator, and the total current in the circuit will be but small. If the work to be done by the machine is considerable, it will slacken its speed, and also diminish its opposing or back E.M.F., causing an increase of the current in the circuit. If the work required is greater than the efficiency of the motor will allow it to do, the rotation will cease altogether, and we shall have a repetition of the case considered above. The experiment is an instructive and simple illustration of the electrical transmission of mechanical power.

The above experiments prove conclusively that the continuous current dynamo is a reversible machine, and therefore it may be inferred that any good continuous current generator can also be used as an electro-dynamic machine, or, more briefly, an electric motor. As a general principle this is true; but, apart from other considerations, to which we shall allude later, the reversal of the current in the armature somewhat alters the physical conditions. In Fig. 564 the motor brushes are still in the correct position for approximately sparkless reversal in a generator, but the current having been reversed, the armature reactions are reversed, and, according to our previous reasoning (*see* page 504), the brushes should now be placed on the other side of the symmetrical line, where they will be *behind* instead of in front of the symmetrical position. In other words, the lead of the brushes in a generator becomes a *lag of the brushes* in a motor. It should be noted that the current in the belt of conductors between the dotted lines *bc* and *ad* (Fig. 562) will still tend to *demagnetise* the field magnets. This fact, as we shall see later, has an important bearing on the regulation of the speed in certain cases.

To examine this important point a little further, take the case of a shunt-wound machine, such as is depicted in Fig. 565, and suppose that some kind of generator is placed in the "main circuit," such that a

current is driven round that circuit in the direction indicated by the arrows, which is opposite to the direction in which the current would flow if the shunt machine were itself acting as a generator (compare Fig. 564). It will be seen that the current through the field-magnet circuit will be in the same direction as that shown in Fig. 484, whilst the current in the armature will be reversed. In these circumstances the armature will rotate in a clockwise direction as before, but the dynamo will act as a motor. The current in the armature being reversed, the magnetic field due to this current will have an effect on the magnetic field set up by the field magnets opposite to that which it has when the dynamo is acting as a generator. In the latter case the effect is such as to rake the resultant field round in the direction of rotation; therefore in the case of the *motor* the resultant field is *raked backward*, and to minimise sparking the brushes must be set back as shown in the figure, or, as it is sometimes said, given a *backward lead*, whereas in the case of a generator they have a forward lead. We prefer to use the term *lag* instead of the self-contradictory expression "backward lead."

Since the field and the direction of rotation are the same as before, the E.M.F. set up is in the same direction as in the case of the generator (Fig. 564). But as the current in the armature has been reversed, this E.M.F. is now opposed to that current, and is therefore a *back E.M.F.* in accordance with the general principle already enunciated.

**Modern Motors (early forms).**—Considering the space we have already devoted to the principles underlying the construction of continuous current dynamos, and the numerous descriptions we have given of actual machines, it might appear to be superfluous to describe specially machines designed to run as motors instead of as generators. But it must be remembered that, although the general principles governing the chief lines of the design are the same, an electric motor has frequently to be used under conditions very different from those of a generator, and the usage to which it is subjected is often rougher. Moreover, in some applications of electric motors, for instance, for electric locomotion, the question of weight assumes a relatively greater importance than in generators. Amongst the minor points of difference may be mentioned the greater care which must be taken with the lamination of the iron of the magnetic circuit in order to avoid eddy currents, and that special attention must be paid to mechanical arrangements by which the magnetic drag on the current-

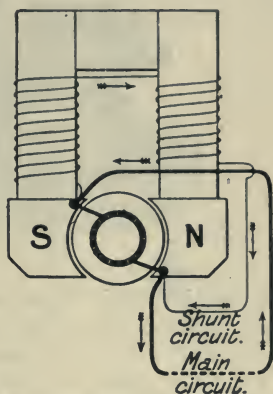

Fig. 565.—Armature Reactions in a Continuous Current Motor.

carrying wires is transmitted to the shaft. It thus happens that various modifications in details have to be introduced, and therefore a brief description of one or two machines may not be uninteresting here.

**The Immisch Motor.**—During the early development of the subject many good motors for mining and traction work were constructed by the

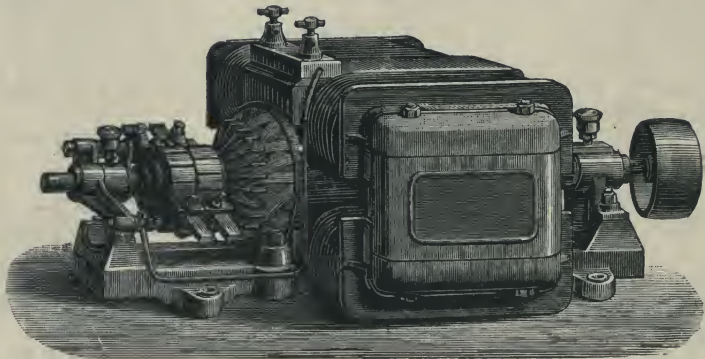

Fig. 566.—The Immisch Motor.

General Electric Traction Company from the designs of their engineer, Mr. A. T. Snell. These motors were known as "Immisch" motors, the earlier ones of this type having been designed by Mr. Moritz Immisch. Fig. 566 gives a perspective view, and Fig. 567 a longitudinal section, one-tenth of full size, of one intended to give 8 horse-power on the shaft at 1,400 revolutions per minute. The armature was ring wound, and its

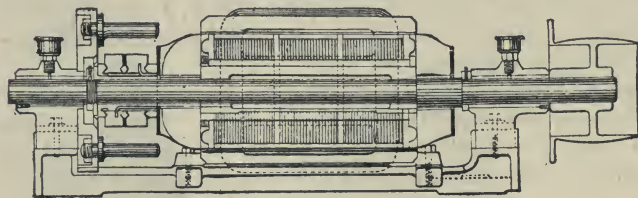

Fig. 567.—Longitudinal Section of the Immisch Motor.

core consisted of thin iron discs, with thicker discs at intervals, the latter having projecting teeth which materially helped to keep the conducting

wires in their places. The commutator was peculiar, being divided into two sections with the alternate bars in each. As the brush or brushes slide across both sections, the effect is to short-circuit for an appreciable part of a revolution the coils which are passing through the neutral positions. It is claimed that this device diminished the troublesome effects due to cross magnetisation, and rendered changes of lead unnecessary. The details of the connections to the commutator can be seen in Fig. 567.

An excellent method was employed in this motor for transmitting the acting forces from the core discs to the shaft. Two gun-metal cones *ff*



(Fig. 568) were threaded on the shaft, and lightly keyed to prevent them slipping round. In these cones three coned grooves were cut, as shown,  $120^\circ$  apart, and received three gun-metal bridge pieces or flanges *b* with projecting lugs to hold the core discs. The latter being in their places, if the nut *n* be now tightened up, the bridge pieces will be forced outwards, and the core discs will be rigidly connected to the shaft through the medium of the bridge pieces.

The above motor weighed 350 lbs., and had an efficiency at full load of 85 per cent. The larger motors of this type had drum armatures and a still higher efficiency. Thus the 30 horse-power motor, taking about 50 amperes at 500 volts and weighing 1,870 lbs., had a net efficiency of about 90 per cent.

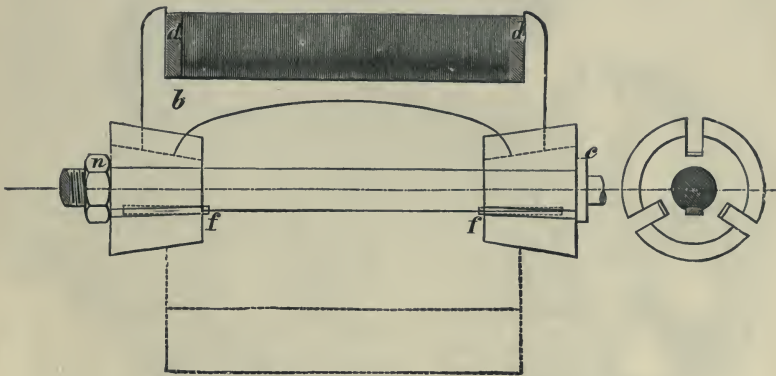

Fig. 568.—Mechanical Connection of Core Discs to Shaft of the Immisch Motor

**Tramcar Motor.**—To emphasise the great modifications which the circumstances under which the motor has to be used may introduce into the design, we give in Fig. 569 an illustration of a type of motor manufactured in 1892 by the General Electric Company of New York, and largely used on electric tramcars. The motor is of 50 horse-power, and is shown geared to the axle of a car. It is of the ironclad type, and so completely are the armature and field-magnet coils protected, that water may be poured over it, or it may be run through water up to the lower side of the bearings without any injury. The armature, which is about 20 inches in diameter with a 6-inch face, is of the usual Pacinotti ring type, there being 64 grooves with 14 windings of thick wire in each. At the left hand end the armature shaft carries a pinion whose teeth gear into a larger wheel on the axle of the running wheels. Both pinion and wheel are enclosed in a dust- and water-proof case partly filled with heavy lubricating oil, in which

they work noiselessly, and are well protected from the grinding action of grit and dust raised by the rapidly moving car. Carbon brushes are used, which are fixed in stationary brush-holders, clamped in slots on each side of the bearing at the commutator end, and which can be quickly removed for inspection or renewal of the brushes. Such brushes are fixed without lead or lag, and allow the armature to be run in either direction.

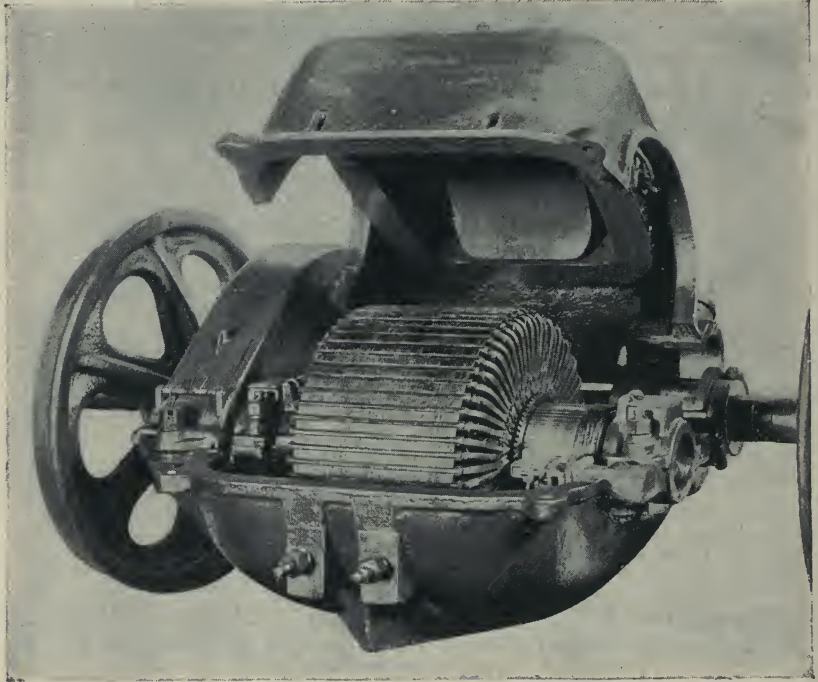

Fig. 569.—Fifty Horse-power Waterproof Railway Motor (1892).

The part of the motor which differs most from the usual generator type is the field-magnet. This consists of two rounded, shell-shaped iron castings, hinged together at the back or axle end, and firmly clamped up, when the motor is used, by four steel bolts at the front and back. The figure shows the upper half of the magnet turned up on the hinges so as to show the interior. The brasses of the axles are held in position between the two castings, and can be easily replaced when worn out. In the interior of the upper casting can be seen the upper pole-piece projecting downwards so as to encircle the armature when the casting is bolted down. There is only one magnetising coil, which is slipped over this upper pole-piece, and is

thus well protected from mechanical injury. It also, being unbalanced by a similar coil on the lower pole-piece, exerts a lifting pull on the armature, which takes a considerable portion of the weight of the latter off the bearings when running at normal load. The lower pole-piece consists of only a slight inward projection from the lower shell.

**Small Electric Motors.**—The range of power for which electric motors can be built is very great; they can be adapted either to the heaviest engineering requirements or be made small enough to do the lightest work. We shall conclude our remarks at this point by describing two motors which have been widely used for light work.

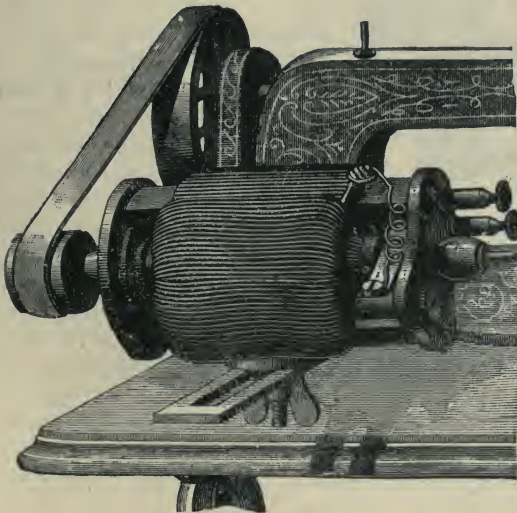

Fig. 570.—Griscom's Motor.

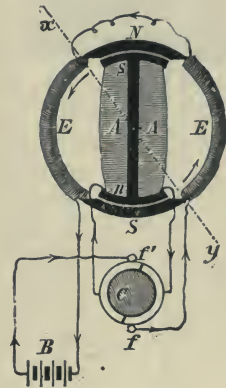

Fig. 571.—Section.

Griscom's motor in Fig. 570 is shown working a sewing-machine. Fig. 571 gives a section of the same. The shuttle armature *AA* is surrounded by the tube-shaped electro-magnet *EE*, which has its poles at *N* and *S*. A change in the direction of the current is brought about by the split ring commutator *C* every half-revolution. The current coming from the battery or generator *B* passes through the contact spring *f*, and the left commutator segment, into the coils of the armature; from here through the right-hand commutator segment, and the contact spring *f*, into the coils of the electro-magnets *EE*, and then back again to the battery. When the armature, owing to the attraction of dissimilar and repulsion of similar magnetic poles, has reached the line *xy*, the current is reversed in it by the action of the



commutator, and with the reversal the polarity changes and causes the armature to continue its rotation in the same direction. Griscom's motor has a length of about 4 inches, and weighs 2.5 lbs. A bichromate battery of six cells may be used to drive it.

**Edison's Electric Pen.**—The smallest electromotors are probably those used by Edison for the electric pen, as shown in Fig. 572. The pen is used to perforate a sheet of paper, which can be employed as a stencil-sheet to print from. The machine is 1.6 inch high and 0.8 inch wide. The electro-

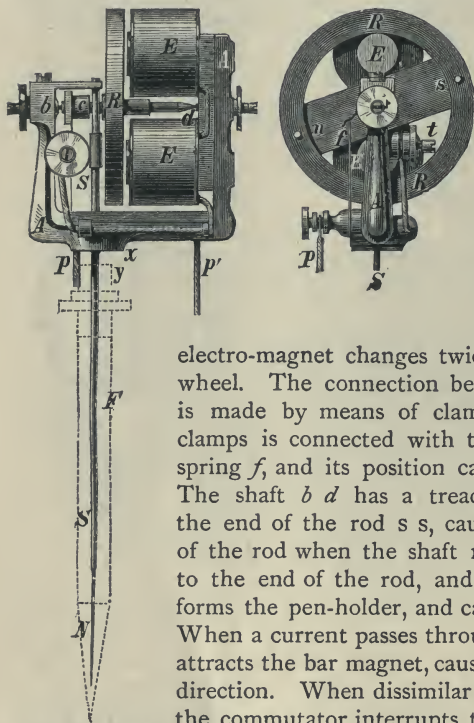

Fig. 572.—Edison's Electric Pen.

magnet  $E E$  is fixed to the frame  $A A$ ;  $R$  is a little fly-wheel, the ends of whose axle rest in  $b$  and  $d$ , and which rotates immediately before the poles of the electro-magnet  $E$ . This fly-wheel carries a steel bar magnet  $n s$ , arranged as shown in the figure. The commutator  $c$  is fastened upon the axle  $b d$  in such a way that the direction of the current

sent through the coils of the electro-magnet changes twice for every full revolution of the wheel. The connection between the coils and battery wires is made by means of clamps, at  $p$  and  $p'$ . One of these clamps is connected with the commutator by means of the spring  $f$ , and its position can be regulated by the screw  $t$ . The shaft  $b d$  has a treadle-shaped crank, which actuates the end of the rod  $s s$ , causing an up-and-down movement of the rod when the shaft rotates. The needle  $N$  is fastened to the end of the rod, and passes through a tube  $F$ , which forms the pen-holder, and can be screwed to the frame at  $x y$ . When a current passes through the electro-magnet, the latter attracts the bar magnet, causing the wheel to turn in a certain direction. When dissimilar poles stand opposite each other, the commutator interrupts the current in the electro-magnet, and the wheel continues to move; the commutator again makes contact and the currents flow now round the electro-magnet

in the opposite direction; the polarity will be changed, so that similar poles—for instance,  $n$  of the bar magnet and  $N$  of the electro-magnet—are near each other. Repulsion will take place, and will cause the wheel to continue its rotation. The wheel makes 65 revolutions per second, during which it lifts the needle up and down 130 times. From the writing thus produced 4,000 or 5,000 copies may be taken. A small two-cell bichromate battery is sufficient to supply the necessary current.

### III.—ELEMENTARY THEORY OF CONTINUOUS CURRENT MOTORS.

Upon the existence and magnitude of the back-electromotive force above referred to depends the capacity of any given motor to enable us to utilise electric energy that is supplied to it in the form of an electric current. In discussing the dynamo as a generator, we have pointed out many considerations, the observance of which would tend to improve the efficiency of such generators. It is needless to say that many of these considerations also apply to motors. The efficiency of a motor in utilising the energy of a current depends not only on its efficiency in itself, but on another factor, namely, the relation between the electromotive force which it generates when rotating, and the potential-difference at which the current is supplied to it. A motor which itself in running generates only a *low* electromotive force cannot, however well designed, be an *efficient* or economical motor when supplied with currents at a *high* potential-difference. A good *low-pressure* steam-engine does not become more "efficient" by being supplied with *high-pressure* steam. Nor can a high-pressure steam-engine, however well constructed, attain a high efficiency when worked with steam at low pressure. Analogous considerations apply to dynamos used as motors. They must be supplied with currents at pressures for which they are constructed.

**The Efficiency of Electric Motors.**—The efficiency with which a good motor utilises the electric energy of the current depends on the ratio between its counter-electromotive force and the electromotive force or P. D. of the current which is supplied to it. No motor ever succeeds in turning into useful work the whole of the energy of the currents which feed it, for it is impossible to construct machines without electrical or mechanical resistance, and whenever there is such resistance part of the energy of the current is wasted in ohmic and frictional heat.

Let us consider the efficiency of a *series-wound motor* worked by a current from mains kept at a constant P. D. Let  $w$  stand for the whole electric energy supplied per second by the current, and let  $w$  be that part of the power which the motor transforms into mechanical work. The difference between these quantities is the equivalent of  $c^2 R$ , or that part of the power of the current  $c$  which is wasted in useless heating of the parts of the circuit where there is electrical resistance. If  $H$  be the measure of this heat, and  $J$  Joule's mechanical equivalent of a unit of heat, then

$$w - w = H J = c^2 R$$

$$\therefore w = W - c^2 R.$$

But if  $\mathcal{E}$  be the P. D. at the terminals of the motor,  $w = \mathcal{E} c$ ,

$$\text{and } c = \frac{\mathcal{E} - E}{R} \therefore w = \mathcal{E} \frac{\mathcal{E} - E}{R}$$

$$\begin{aligned} \therefore w &= \mathcal{E} \frac{\mathcal{E} - E}{R} - \frac{(\mathcal{E} - E)^2}{R} \\ &= \frac{\mathcal{E} E - E^2}{R}. \end{aligned}$$

$$\begin{aligned} \text{Hence the electrical efficiency } \frac{w}{W} &= \frac{\mathcal{E} E - E^2}{R} \div \frac{\mathcal{E} (\mathcal{E} - E)}{R} \\ &= \frac{E}{\mathcal{E}} = \frac{\text{back E. M. F.}}{\text{P. D. at terminals of motor.}} \end{aligned}$$

Since  $w = \mathcal{E} c$ , therefore  $w = E c$ . Again, if  $s$  be the current that would flow if the motor were not allowed to rotate,  $c$  being the current when the motor works, we have

$$\begin{aligned} s &= \frac{\mathcal{E}}{R} \text{ or } \mathcal{E} = s R, \\ c &= \frac{\mathcal{E} - E}{R} \text{ or } E = \mathcal{E} - c R = s R - c R. \end{aligned}$$

$$\text{Hence the efficiency or } \frac{E}{\mathcal{E}} = \frac{s R - c R}{s R} = \frac{s - c}{s},$$

or the fall of strength of the current divided by the original current.

From which it appears that we can calculate the efficiency at which the motor is working by observing the ratio between the fall in the strength of the current and the original strength, a law of efficiency which has been known for many years, but has often been strangely misapprehended.

**The Maximum Activity of a Motor.**—Let us now go back to the equation

$$w = \mathcal{E} c - c^2 R,$$

and ask for what value of  $c$  this  $w$  will be a maximum.

By adding and subtracting  $\frac{\mathcal{E}^2}{4R}$ , we may write the equation thus,

$$w = \frac{\mathcal{E}^2}{4R} - R \left( \frac{\mathcal{E}}{2R} - c \right)^2.$$

The last term, being a square, is always positive, whatever  $c$  may be; hence,  $w$  will be greatest when the term to be subtracted is nought, that is when

$$c = \frac{\mathcal{E}}{2R}$$

That is to say, *the mechanical work given out by the motor is a maximum when the motor is geared to run at such a speed that the strength of current is half that of the current that would flow if the motor were still.* This law is called Jacobi's law of maximum activity. When the motor works so as to reduce the current to half,



$$\begin{aligned} \text{since } c &= \frac{\mathcal{E} - E}{R} \\ \text{and also } c &= \frac{\mathcal{E}}{2R}, \\ \therefore \mathcal{E} - E &= \frac{1}{2} \mathcal{E} \\ \text{and } \frac{E}{\mathcal{E}} &= \frac{1}{2}. \end{aligned}$$

But we have proved that this is equal to the efficiency; hence, when the motor does its maximum of work per second the efficiency is 50 per cent.

**Relation between Electrical and Mechanical Quantities.**—So far we have dealt only with the electrical components of the energy absorbed by the motor; but from the point of view of the user the mechanical components are, perhaps, even more important. Thus the electrical power  $w$  absorbed by the armature is transformed into mechanical power, which may be expressed mechanically as the product of the *torque* or turning moment exerted on the material of the armature and the angular velocity of rotation. Now let

$$\begin{aligned} T &= \text{the torque (in megadyne-centimetres } \times 10), \\ \omega &= \text{angular velocity (in radians per second),} \\ n &= \text{number of revolutions per second;} \end{aligned}$$

$$\text{then } \omega = 2\pi n$$

$$\text{and } w = T\omega = 2\pi n T$$

if we assume that the quantity  $T$  is measured at the moment of conversion.

$$\text{But since } w = EC$$

$$\text{and } E = nZN \text{ (see page 513)}$$

$$\text{we have } 2\pi n T = nZN C$$

$$\text{or } T = \frac{ZN}{2\pi} C$$

Since  $Z$  and  $N$  are constants, when the field magnets are saturated, this shows that *in a series-wound motor the torque is proportional to the current* if frictional or heat losses be neglected. This is a most important result, for series-wound motors are now largely used on constant P.D. mains for electric traction purposes. We have already seen that when the motor is moving slowly the current is large, because of the smallness of the back E.M.F. The above result shows that this large current will exert a correspondingly large torque, which is just what is wanted when the car is getting up speed at starting.

A more exact relation between torque and current is given by the full-line curve of Fig. 573, for which, and the two following curves, the writer is indebted to Dr. S. P. Thompson. In this curve the values of the current are plotted horizontally, and the corresponding values of the torque vertically. The dotted line is tangential to the curve at infinity.

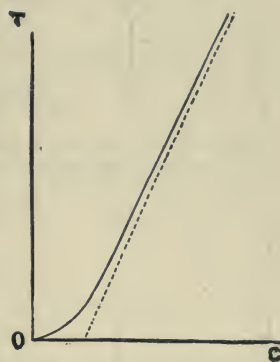

Fig. 573.—Relation between Torque and Current.

**Mechanical Characteristics.**—We do not propose to pursue the analysis further here, but just as we have given (*see* page 511) curves for dynamos showing the connection between the electrical quantities, voltage, and current, which we have called characteristics, so we may draw curves for motors to show the connection between the mechanical quantities, speed, and torque. Such curves we may call, by analogy, *mechanical characteristics*.

In Figs. 574 and 575 are drawn the mechanical characteristics for a series and a shunt motor respectively. In both figures two curves are given for two different conditions of supply, viz., constant P. D. ( $\mathcal{E}$ ) and constant current  $c$ .

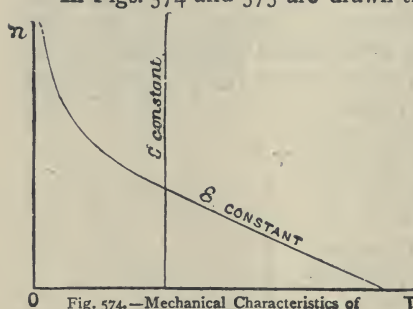

Fig. 574.—Mechanical Characteristics of a Series Motor.

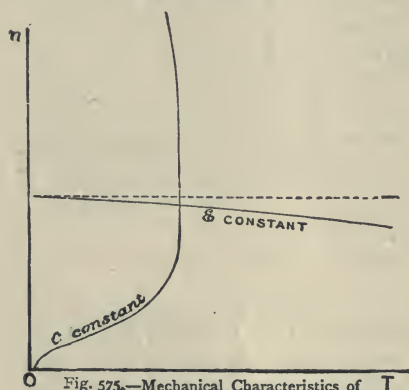

Fig. 575.—Mechanical Characteristics of a Shunt Motor.

With a supply at constant pressure the series motor (Fig. 574) has at low speeds a large torque, which diminishes at first slowly, and then with increasing rapidity as the speed rises. On the other hand, under the same conditions, a shunt motor (Fig. 575) runs at an almost constant speed, but rather more slowly at large torques (which, in this case, means heavy loads) than at small ones.

Supplied with a constant current, on the other hand, a series motor (Fig. 574) will run with a constant torque at all loads, the speed increasing with the load. Under similar circumstances a shunt motor has a curious characteristic curve (Fig. 575). At high speeds the torque is nearly constant, showing a tendency, however, to diminish at very high speeds. At low speeds the torque and speed diminish together, though not proportionally.

Supplied with a constant current, on the other hand, a series motor (Fig. 574) will run with a constant torque at all loads, the speed increasing with the load. Under similar circumstances a shunt motor has a curious characteristic curve (Fig. 575). At high speeds the torque is nearly constant, showing a tendency, however, to diminish at very high speeds. At low speeds the torque and speed diminish together, though not proportionally.

**Distinction between the most Economical and the most Rapid Rate.**—If the P. D. of the supply be  $\mathcal{E}$  volts, and the counter E. M. F. of a *series motor* be  $E$  volts,  $c$  being the current, then, as we have seen, we have the following simple relations:—

- (1) The energy taken from the supply circuit =  $c \mathcal{E}$ .
- (2) The energy absorbed by the motor =  $c E$ .
- (3) The efficiency of the motor =  $\frac{E}{\mathcal{E}}$ .

$$(4) \text{ The current } c = \frac{\mathcal{E} - \mathcal{E}}{R}.$$

$$(5) \text{ The work per sec. } w = T\omega = \mathcal{E}c - c^2 R.$$

$$(6) \text{ The torque } T = ac \text{ where } a = \frac{ZN}{2\pi}.$$

The second of these equations shows that the maximum mechanical work per second that can be given out by this electric motor is equal to the product of the current into the back E. M. F. There are two ways, therefore, of altering the work per second given out by an electric motor. We may either increase the current or increase this back E. M. F. Let us consider the first case: We shall double the current, and at the same time keep the P. D. of the battery the same. To do this we shall have to let the electric motor run at such a diminished speed that the difference between the P. D. of the mains and the back E. M. F. of the electric motor is double what it was before. Although, therefore, we have doubled the current and the energy furnished by the mains, we have not doubled the energy given out by the motor. Where is the additional energy lost? The answer is obvious, since as the waste of power in the production of heat in the wires is proportional to the square of the current, four times as much power will be wasted as in the previous case. Consequently, increasing the current is a ruinous way of increasing the useful energy transformed.

Now take the other case. Let us double the P. D. of the mains, and run the motor at such an increased speed that the current remains constant; to do this we must more than double the back E. M. F. of the motor. For as  $\mathcal{E}$  becomes  $2\mathcal{E}$ ,  $\mathcal{E}$  must become  $(\mathcal{E} + \mathcal{E})$ , that the difference may be unaltered. The energy now furnished by the mains will be double what it was before, the energy given out by the motor more than double what it was before, and the energy wasted in heating the conductors will be the same as before.

Consequently we conclude that, as far as the motors are concerned, the most efficient way to transmit energy electrically is to use a generator producing a high E. M. F., and a motor producing a high counter E. M. F. We thus arrive on different grounds at a result previously obtained (*see* page 573).

When a motor is worked from constant P. D. mains, the above equations lead us to the result that if we wish to produce the work *most economically* we must, by diminishing the load on the motor, allow its speed to increase until the reverse E. M. F. it produces is only a little smaller than the P. D. of the mains. When this is the case, the current is very small, and the activity of the motor, or the work it produces in a given time, is comparatively small. If, on the other hand, we desire the motor to do work *most quickly*, then we see that we ought to put such a load on the motor that its speed will



set up a back E. M. F. equal to half the P. D. of the mains. The efficiency is then about one-half; that is, half the energy is wasted in heat.

The difference between these two considerations of maximum values, namely, how to obtain work *most quickly*, or how to transmit work *most economically*, must carefully be borne in mind in deciding what speed should be given to a motor in any given case. Jacobi's law concerning the maximum work of an electric motor, supplied with currents from a source of given pressure, refers to the former. The mechanical work given out by a motor is a maximum when the motor is geared to run at such a speed that the current is reduced to half the strength that it would have if the motor were stopped. In these circumstances only half the energy furnished by the external source is utilised, the other half being wasted in heating the circuit. Jacobi's law does not, however, state that no motor, however perfect in itself, can convert more than 50 per cent. of the electric energy supplied to it into actual work. Hence, when activity without regard to economy is the main consideration, Jacobi's law must be applied; but when economy has also to be considered, this law does not apply. In this case  $\frac{E}{\mathcal{E}}$  must be as large as possible. If, therefore, much power is to be transmitted,  $\mathcal{E}$  and  $E$  must both be large. In other words, it is an economy to work at high pressures. The importance of this matter cannot be overrated.

#### IV.—MONO-PHASE ALTERNATE CURRENT MOTORS.

An alternator generating alternate currents, whether mono- or poly-phase, is not reversible in the same sense as a continuous-current dynamo; that is, if supplied only with currents similar to those which it generates, it would not run as a motor. This is due, in the first place, to the fact that it is not a self-exciting machine, and that in order to act as a generator its field magnets must be excited by a continuous current.

But even if we arrange to excite the field magnets separately by any of the methods used, when the machine acts as a generator, another difficulty presents itself when we attempt to run it as a motor. On passing the alternate current into the armature coils, these coils will rapidly change their polarities at a rate depending on the periodicity of the current supplied. Between such rapidly changing poles and the fixed poles of the field magnets there can be no mechanical action tending to set the armature in rotation. If, however, the armature be already in rotation and at such a speed that the polarities of the armature magnets change when they are in positions to be effectively acted upon by the fixed poles of the field magnets, the rotation will be maintained, and work may be done by the rotating armature.

From this we draw two deductions:—firstly, that such a machine cannot be self-starting as a motor, but must be run up somehow to the

speed at which the above condition is fulfilled; and, secondly, when once the machine has fallen, as it were, into step and the motor action has commenced, it will run always at the *one speed*, which ensures that the changes of polarity in the armature shall always be made at the right moment. Such a motor is known as a **synchronous motor**, and the one speed at which it can run is fixed by the periodicity of the alternate current and the number of poles on the motor. Thus a generator having 10 poles (alternately N and S) on its field magnets, if supplied with a current of the proper voltage having  $100 \sim^*$  per second, would fall into step as a motor if speeded up to 1,200 revolutions per minute (20 per second), and would continue to run at this speed until overloaded, when it would stop dead, and could not start again of its own accord, although still supplied with current. The speed named is that which allows five complete alternations of current in one revolution. At this speed back E. M. F.'s would be set up (of the proper periodicity and phase), which would enable the motor to absorb power from the driving current.

We have seen that the ordinary *continuous current dynamo* is reversible, and can be run as a motor when supplied with continuous currents from an external source. If the currents in the field magnets and armature are in the same direction as when the machine is used as a generator the direction of rotation will be reversed, but if the connections be arranged so that the current in one only, for instance the armature, be reversed, then the machine will run round in the same direction as before. Suppose now that with the machine properly arranged to run as a motor the driving current be suddenly reversed. This will reverse the current in both the armature and the field magnets, and therefore the direction of rotation will remain unchanged. From this we should be inclined to infer that the machine when fed with alternate currents would still act as a *self-starting motor*. So far as the main principle is concerned the inference is correct, but unfortunately with large machines the enormous inductance, especially of the field-magnet circuit, introduces complications which are fatal in practice. The difficulty may be partly diminished by laminating the iron of the field magnet so that "eddy" currents, which tend to delay the change of the magnetic flux, cannot be formed. But the inductance still remains, introducing phase complications and vicious sparking at the brushes, under which the commutator rapidly deteriorates. The practical result was that, until recently, only small continuous-current motors could be run with alternate currents, and they had their field-magnet iron laminated. The lower the periodicity of the alternate currents the easier is it to use them in this way.

\* The symbol  $\sim$  is used to denote one complete period per second, so that  $100 \sim$  means 100 periods per second.

A motor of this type, designed by Rechniewski, and built in France in 1888, is shown in Fig. 576. It was like an ordinary continuous-current motor, with the exception that the core of its field magnet was built up from sheet-iron stampings, and was therefore laminated. The armature was 8 inches in diameter, and was intended to run at 1,400 revolutions per minute when supplied with a single-phase alternate current of 100 amps. at 115 volts. When running thus as an alternate-current motor it sparked furiously.

Returning now to the reversed alternate-current generator, in order

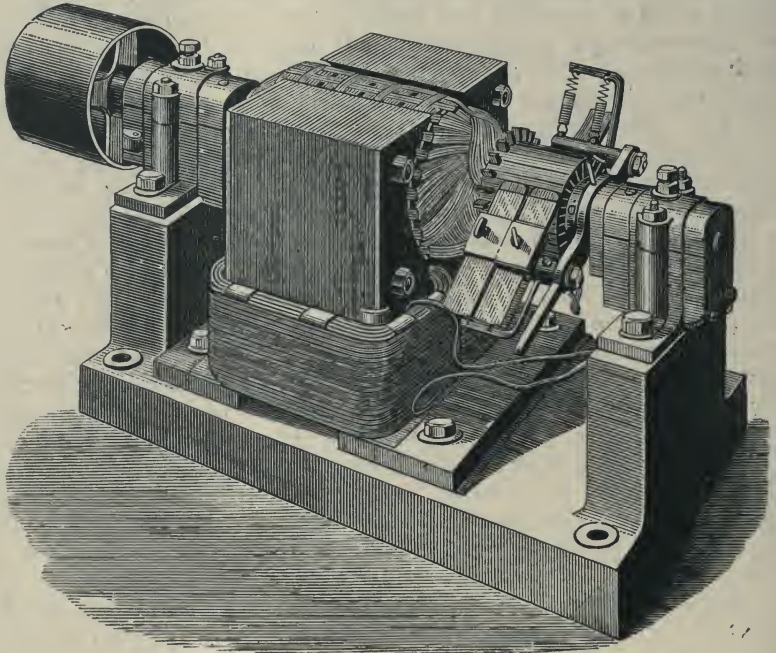

Fig. 576.—Rechniewski's Mono-phase Alternate-current Motor (1888)

to ensure that the motor action shall be continuous it is necessary and sufficient that the magnetic fluxes in the moving and fixed parts should always be such as to produce stresses tending to maintain the rotation of the former. In the reversed alternate-current generator, this is automatically accomplished only at one definite speed, and the motor is therefore not self-starting. If, however, we arrange that at definite positions of the rotating part the connections between it and the fixed part are reversed, we obtain a machine which at all speeds (apart from disturbances due to inductance) will act as a motor whatever the direction of the current supplied. This is the principle



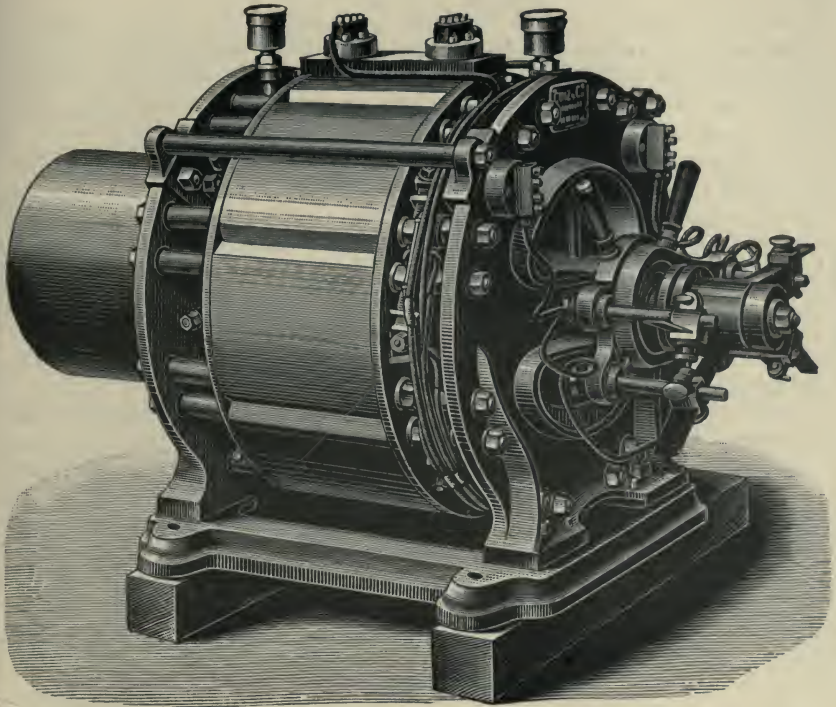

Fig. 577.—Ganz & Co.'s Mono-phase Motor.

of the single-phase motor shown in Fig. 577, as built by Messrs. Ganz & Co. In this machine, which is multipolar, the armature coils are fixed whilst the field magnet coils revolve, carrying round with them a commutator for reversing the connections in the manner referred to. A diagram of the electrical connections is given in Fig. 578, in which *LL* are the main conductors bringing the alternate currents to the motor. The armature *A* is joined directly to these leads, but to reach the field magnets *M* the current has to pass through the brushes *B*, *B*<sub>2</sub> and the commutator *c*. In the diagram the alternate sectors are marked differently to indicate that all the shaded sectors are connected to end No. 1 of the magnetising circuit, and all the others to end No. 2. As, therefore, the commutator

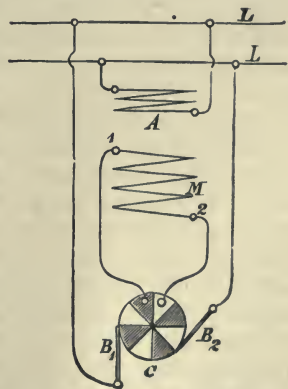

Fig. 578.—Circuits of Ganz & Co.'s Mono-phase Motor.

rotates, the relative direction of the currents in A and M is changed whenever the brushes pass the divisions between the sectors. But the magnets rotate with the commutator, and it is therefore easy to arrange that the change shall be made at the moment when the motor action of the magnetic stresses is just about to cease and be reversed.

It follows that, except at the synchronising speed, the connections of M are changed most frequently when there is a fairly large current flowing, and therefore that vicious sparks will appear at the brushes on account of the large induction of the magnets. To kill these sparks double brushes are used on each side, as can be seen in Fig. 577. They are shown diagrammatically ( $B_1, B_2$  and  $B_3, B_4$ ) in Fig. 579. These brushes short-circuit the magnet coils for a brief period at the moment of changing over, and the energy of the magnetic field is changed into heat in the short-circuited circuit.

Before switching on the current the motor should be given an impulse in the right direction, for otherwise it may start to run the wrong way and run against its brushes. When once started the speed will accelerate rapidly until it falls into synchronism with the supply current, and this speed may be regarded as the position of equilibrium. If disturbed the motor tends to return to it, for at this speed it can absorb energy most readily from the supply. The machine is therefore a *self-starting synchronous motor*.

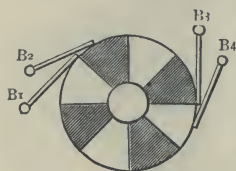

Fig. 579.—Short-Circuiting Brushes on Commutator.

**Induction Motors.**—A large number of mono-phase motors depend upon the interaction between the currents supplied and other currents produced from these by induction. Many of these motors employ, either for starting or running, *rotating magnetic fields*, which are a marked feature of poly-phase motors, in connection with which they are most readily explained. We shall, therefore, now deal with poly-phase motors, and return later on to the mono-phase class.

#### V.—ALTERNATE CURRENT INDUCTION MOTORS.

**Poly-phase Motors.**—One of the chief causes which led to the rapid development of the use of poly-phase currents for the transmission of power over long distances was the possibility of building self-starting motors which, as transformers of electric into mechanical energy, were quite able to challenge the existing continuous current motors. We have seen that alternate current transmission in itself has certain advantages over continuous current transmission, notably in the possibility of using higher voltages, and when the motor difficulty was satisfactorily overcome with two- and three-phase currents, progress was soon recorded.

**Rotating Magnetic Fields.**—The chief characteristic of these motors is that instead of employing a magnetic field fixed in position, as in the

older motors, using continuous currents or mono-phase alternate currents, they use a field in which the magnetic flux is continually rotating round an axis. Such a field can, of course, be produced by spinning a horse-shoe magnet round the median line which lies in the direction of its length. But with di-phase and tri-phase currents the rotation of the field can be produced without any of the mechanical parts of the electro-magnet moving.

Rotating fields appear to have been first produced by Mr. Walter Baily in 1879 in a model which he exhibited at a meeting of the Physical Society of London. Very little more was done, however, until the year 1885, when Professor Ferraris, of Turin, took up the subject, and constructed motors in which rotating magnetic fields were used. In 1887 Nikola Tesla, in a series of comprehensive researches, investigated the properties of such motors, and firmly established the principles involved.

To illustrate how a rotating-field may be produced by poly-phase currents, we reproduce a figure from one of Tesla's papers, as given by

*The Electrician*. In this we have a laminated iron ring overwound with four separate coils A A, B B (Fig. 580), each occupying about 90° of the periphery. The opposite pairs of coils, A A and B B respectively, are connected in series and joined to the leads from a di-phase alternate current generator G, the pair of coils A A being on one circuit,

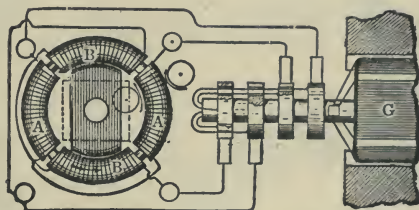

Fig. 580.—Tesla's Rotating-Field Magnet.

and the coils B B on the other. It will be remembered that the currents in the two circuits are in quadrature, and that therefore the maximum in one circuit (A A) occurs a quarter of a period before the maximum in the other circuit. This means that when the current in one pair is a maximum, the current in the other is zero, being just in the act of changing direction (*see* Fig. 530). Now the coils A A alone give a vertical magnetic flux across the plane of the ring. This flux, rising from zero, increases to a maximum upwards, then sinks to zero, reverses, and rises to a maximum downwards, and again sinks to zero, completing the cycle. Similarly the coils B B alone would give an alternate horizontal flux. Combine these two fluxes, taking account of the phase difference. This has been done in a series of eight small diagrams in Fig. 581. In these the magnitudes of the two components and their resultants have been drawn for eight equidistant successive instants of time during a complete cycle. To avoid confusion they are not drawn from the centre of the figure, but from the points 1, 2, 3, 4, etc., on the inner circle of the laminated ring. At instant 1 the vertical flux is at its + maximum, and the horizontal is zero; at instant 2 the vertical flux is still + but decreasing, and the horizontal is



+ and increasing, the resultant is the thick line sloping at  $45^\circ$  upwards to the right; at instant 3 the vertical flux is zero, and the horizontal is at its - maximum; and similarly for the other diagrams. Thus at instant 8 the vertical flux is - and increasing, whilst the horizontal is - and decreasing, the resultant is the thick line sloping at  $45^\circ$  upwards to the left. At points 2, 4, 6, and 8 the increasing fluxes are denoted by full and the decreasing by dotted lines. The laminated iron of the ring is indicated by the circles, and the result is that at the instants chosen the flux across the plane of the ring is directed inwards from the points 1, 2, 3, 4, etc., on the inner periphery of the iron. There will, therefore, appear successively at these points effective north poles, the corresponding south poles being

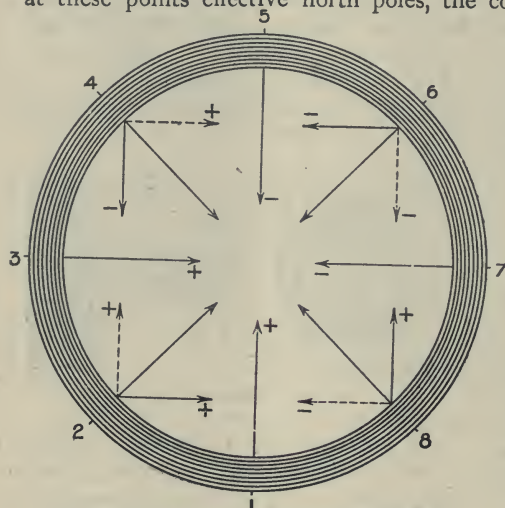

Fig. 581.—Production of a Rotating Magnetic Flux.

simultaneously developed at the points diametrically opposite. These poles travel continuously from one position to the next, and thus we have the magnetic flux across the plane of the ring swinging round and round, completing a revolution without change of intensity during the periodic time of the alternate currents. The rotation of the poles which we have shown in detail takes place in the ring surrounded by the four coils of Fig. 580, when supplied with di-phase currents, but can also be accomplished with coils differently arranged and supplied with either tri-phase or di-phase currents. Some typical cases are shown in Figs. 582 to 585. In Fig. 582 we have three coils on the ring connected "star" fashion (see page 549), that is, one end of each coil is joined to a common junction J, and the other end connected to one of the line wires. If fed with three-phase currents this ring will produce a rotating field which will be strongest in the enclosed space, especially if that space contains iron. In Fig. 583 the ring is overwound continuously, like a Gramme ring, and connections are brought out at three equidistant points  $120^\circ$  apart. This is an example of "mesh" connection, and will also produce a rotatory magnetic field with tri-phase currents. Figs. 584 and 585 are similar to Figs. 582 and 583 respectively, except that they show four coils for di-phase currents instead of three coils for tri-phase currents. There is no tri-phase analogue to Fig. 580.

**Multi-polar Rotating-Fields.**—The rotating-fields so far described are

all bi-polar, there being at every instant a N pole and a S pole at opposite sides of the ring. Even with low periodicities of the alternate currents this leads to a very rapid rotation of the field, for it makes one complete rotation in the periodic time of the current. Thus when the periodicity is as low

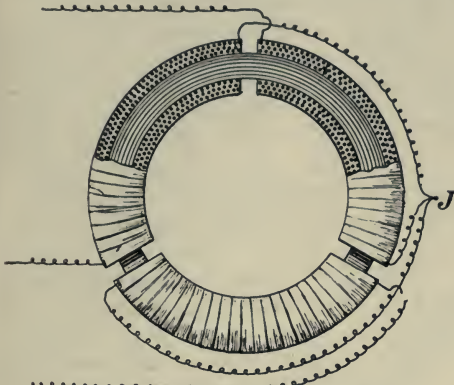

Fig. 582.—Tri-phase Rotating-Field Magnet, "Star" Connected.

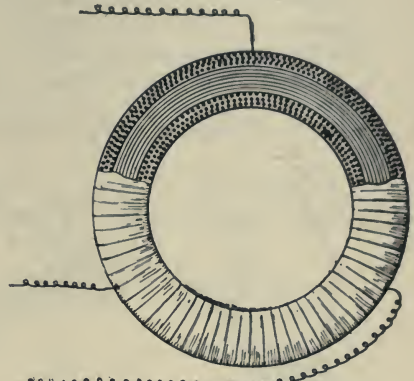

Fig. 583.—Tri-phase Rotating-Field Magnet, "Mesh" Connected.

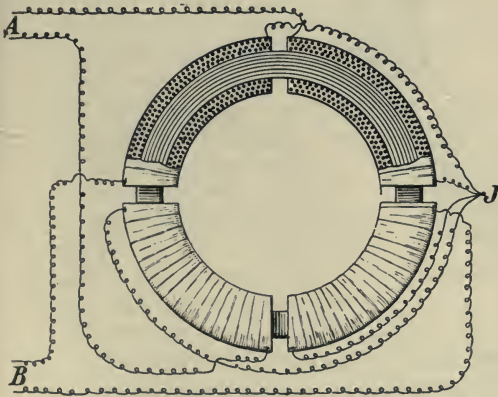

Fig. 584.—Di-phase Rotating-Field Magnet, "Star" Connected.

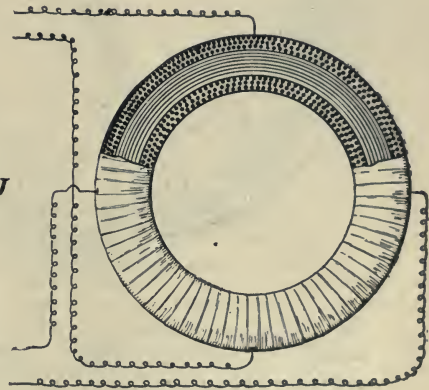

Fig. 585.—Di-phase Rotating-Field Magnet, "Mesh" Connected.

as 25  $\sim$  per second, the field rotates with an angular velocity of 25 revolutions per second, or 1,500 per minute. At a periodicity of 100 the angular velocity is 6,000 revolutions per minute. We shall see presently that the speed of the motor, though not quite so great as the angular velocity of the field, approximates very closely to it, the "slip" between the two, that is their difference in angular velocity, often being not more than 5 per cent. For most mechanical purposes the above speeds are

too high, and we therefore require fields rotating with much lower angular velocities. Tesla perceived this during his early work, and therefore designed machines with multi-polar fields, in which the speed of rotation is diminished proportionately with the increase in the number of pairs of poles.

How such multi-polar rotating-fields can be produced is shown diagrammatically in Fig. 586. Here the windings on the laminated iron ring are divided into twelve sections, which are connected in three groups, A, B, and C, of four sections each, the sections in each group being evenly

placed round the ring with the sections of the two other groups between them. One end of each group is to be connected to the line wire and the other end to the common junction J, from which it follows that the winding given is an example of "star" winding (see page 549). With tri-phase currents the winding will give at every instant four N poles and four S poles round the ring, and in actual working these poles will be on the inner periphery because of the presence of an inner ring or cylinder of good magnetic iron placed, with

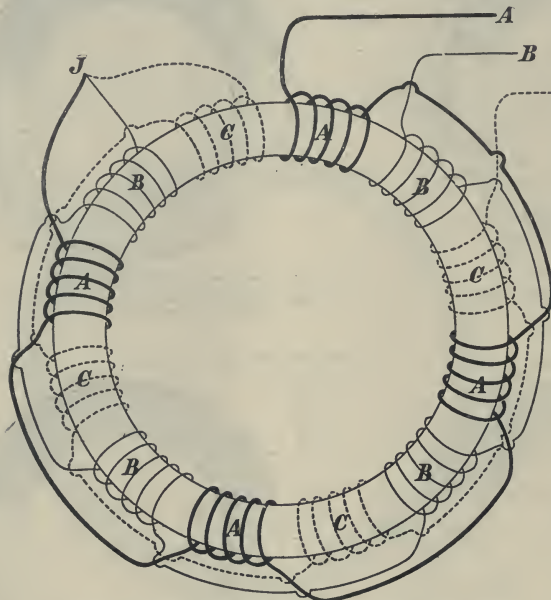

Fig. 586.—Production of a Multipolar Rotating Field with Tri-phase Currents.

the requisite clearance to allow of rotation, as close as is mechanically possible to the outer ring. Each one of these eight poles will make a complete revolution round the ring in four times the periodic time of the alternate currents supplied. Thus, if the supply current has  $50 \sim$  per second, a complete revolution of the field will take place in  $0.08 (= \frac{4}{50})$  of a second, which corresponds to an angular velocity of 750 revolutions per minute in place of 3,000 revolutions per minute, which would be the angular velocity with a bi-polar field at this periodicity.

Similarly a continuously wound Gramme ring tapped at twelve points, joined in three groups of four each to the supply mains, would give an eight-pole rotatory-field. In this case the grouping would be a "mesh" grouping, with each side of the mesh formed of four coils in parallel.



It will not be necessary to multiply examples further, but the reader might find it of interest to work out on paper diagrams of multi-polar arrangements analogous to the bi-polar arrangements of Figs. 582 to 585.

Instead of winding the coils on the ring, the latter may be used as a yoke, and the coils wound on polar projections extending inwards. In these cases the rotation of the field will be more jerky than in the overwound ring examples. If the reader will work out a few simple cases, he will find that frequently two  $N$  poles would follow two  $S$  poles, and that the transfer of the flux from one pole to the next must take place in a series of jumps.

**Rotating-Field Motors.**—We have next to show how the rotating-fields, as above produced, can be used for motor purposes. Returning to Fig. 581, let us suppose that a permanent steel bar magnet  $N S$  (Fig. 587) is pivoted so as to be free to rotate in the space within the ring. The magnet will revolve if the rotations of the field only start slowly enough to allow it to pick up speed. With rapid rotations of, say, 50 or 100 per second, it would be impossible for the magnet to fall into step, though rotation might be produced at lower periodicities, or with more slowly rotating fields, if the magnet were given a vigorous impulse to start with. The arrangement, however, could not be self-starting, and is open to other objections.

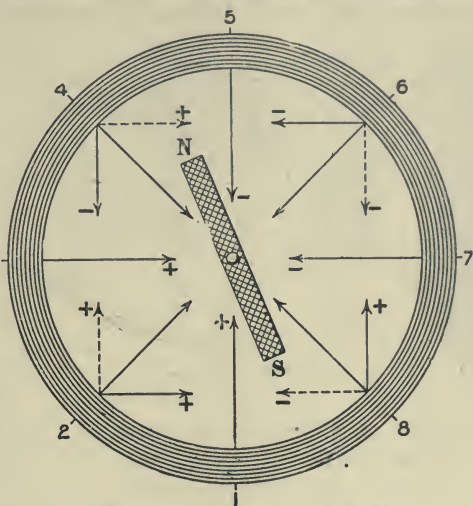

Fig. 587.—Magnet Rotated by a Rotating Field.

We now return to an experiment previously described, that of "Arago's Rotations" (see page 422). In this experiment a horizontal copper disc rotating below a bar magnet pivoted above the disc on a point on the axis of the disc is dragged round in the direction of the motion of the disc, and if this motion is only sufficiently rapid the bar magnet can be made to spin. In connection with this refer to the Faraday disc dynamo (see page 482), and note that the rotation of the disc between the poles of the magnet causes a *radial E. M. F.* in the disc, and that by completing the circuit through sliding contacts on the axle and the periphery a continuous current can be obtained. What, however, will happen if the sliding contacts are removed? The *radial E. M. F.* will still be produced under the magnet poles, and since there are low resistance return paths through the mass of the copper

which is not in the magnetic field, and in which, therefore, there is no E. M. F., swirls or eddies of current will flow radially outwards or inwards under the poles, their circuits being completed in curved paths through the mass of the copper on either side. These current eddies will produce their appropriate magnetic effects.

In the experiment on Arago's rotations we have similar effects, although the magnetic poles are only on one side of the disc. Thus under the N pole (supposed fixed for a moment) we have generated E. M. F.'s directed radially outwards if the rotation of the disc be clockwise. The resulting current as it approaches the edge of the disc spreads out right and left, and returns back towards the centre in curved loops (Fig. 588). The eddy behind the pole produces an upward flux, and that in front of the pole a downward flux, and the pole is repelled

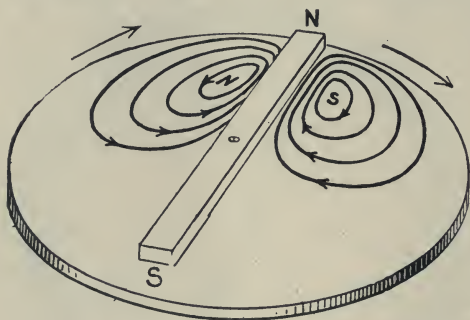

Fig. 588.—Explanation of Arago's Rotations.

by the former and attracted by the latter. The pole, therefore, tends to rotate in a clockwise direction, and if set free to move will follow the disc round. Similar actions tending to rotate the magnet in the same direction occur at the S pole.

The interest for our present purpose in these experiments lies in the fact that, since action and reaction are equal and opposite, if we rotate the magnet and remove all constraint from the copper disc so that it is free to move, we should expect the copper disc to follow the revolving magnet round through the action of the eddy currents set up in the disc. The experiment was made by Herschel and Babbage in 1825, and gave the result expected.

Apply this to one of our rotating-fields, and suppose that the poles are sweeping round on the inner periphery of the flat ring  $ab$  in Fig. 589, an enlarged section of which is shown in Fig. 590. This ring may be regarded as overwound with circuits and supplied with currents in the same way as the ring in Fig. 586. With rotating poles so produced we should naturally substitute a thin copper cylinder  $cc$ , as shown in the figure, for the Arago disc. With, say, a N pole sweeping round clockwise in front of this cylinder, like the magnet N pole in Herschel and Babbage's experiment, we shall obtain a clockwise rotation of the cylinder owing to the interaction of the magnetic flux due to the induced currents in the copper cylinder, and the rotating flux due to the currents in the outer ring. By the rotation of the cylinder

power can be transmitted to the shaft, and work can be done. We have a rotating-field induction motor, albeit a somewhat feeble one.

It will be convenient now to name the two fundamental parts of the machine. The names armature and field magnet, used in generators and continuous-current motors, are apt to lead to confusion here, for the fixed ring is the more analogous to the armature in the other machines, since the magnetic flux in its core is continually changing. Also the rotating part more nearly resembles a field magnet, for in modern machines the magnetic flux in its core is nearly, but not quite, in a fixed direction through the iron. As a matter of fact it slowly revolves with respect to this iron. There is, therefore, strictly speaking, no field magnet in the usual sense. The two parts more nearly resemble electrically the *primary* and *secondary* of an induction coil, except for the fact that there is relative motion. The practice, however, which is least open to objection, and which is now very widely adopted, is to call the primary or fixed part the **Stator** (*i.e.* the part which *stands still*), and the secondary or moving part the **Rotor** (*i.e.* the part which *rotates*). We shall usually employ these names in what follows.

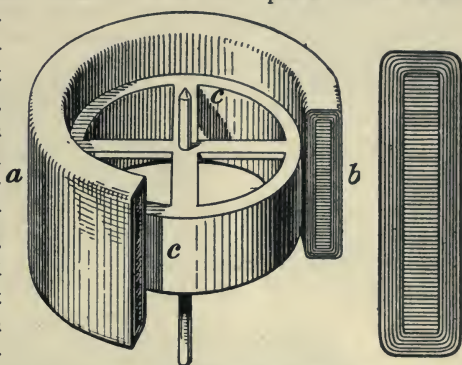

Fig. 589.—Copper Cylinder placed in a Rotating Magnetic Field.

Fig. 590.—Section of Ring.

Return now to the copper cylinder placed in the rotating-field. The cylinder will revolve in the same direction as the field, but the forces acting will be feeble and of little practical value. One obvious method of increasing them is to increase the rotating magnetic flux by improving the magnetic circuit, for it is on this flux that the whole action depends. The flux will be enormously increased if we place behind the copper a heavy iron cylinder built up like the armature core of dynamo machines. The copper will then be only a thin conducting sheet on the face of the iron, and the latter may therefore be brought very close to the iron of the outer ring, especially if the latter, instead of having the wire wound on a smooth core, is wound with the wire lying in grooves between projecting teeth. With these modifications the effective torque will be greatly increased.

Next, in regard to the circuits of the induced currents in the copper cylinder, we may now look upon the mechanical action as the result of the drag on a current-carrying conductor placed in a magnetic field. For this drag to be most effective in a given case the conductor



should be at right-angles to the field at the place where the flux is densest. A very cursory examination of the lines of current flow in Fig. 588 will show how little these lines conform to this condition. Instead of being strictly radial under the rotating pole they leak out

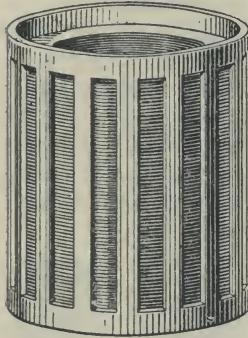

Fig. 591.—Rotating Copper Cylinder, slotted and lined with laminated iron.

sideways in all directions, with a consequent loss of mechanical effect. The same kind of thing happens in the copper cylinder (Fig. 589), where the current lines, instead of being all vertical, break into curved swirls. To direct the currents in the required paths it is only necessary to cut vertical slots in the cylinder, as shown in Fig. 591, leaving sufficient copper top and bottom for the currents to flow round. For this purpose the cylinder may be lengthened, for it is not necessary that the end paths should be within the magnetic field; they obviously add nothing to the torque. We thus arrive at the elementary form of the widely-used **Squirrel Cage Rotor**, so named from the resemblance the barred copper has to the toy

referred to. The figure simply shows the laminated iron and the copper without the mechanical connections to the shaft to which the power developed is to be transmitted.

By slotting the copper the induced currents are constrained to take

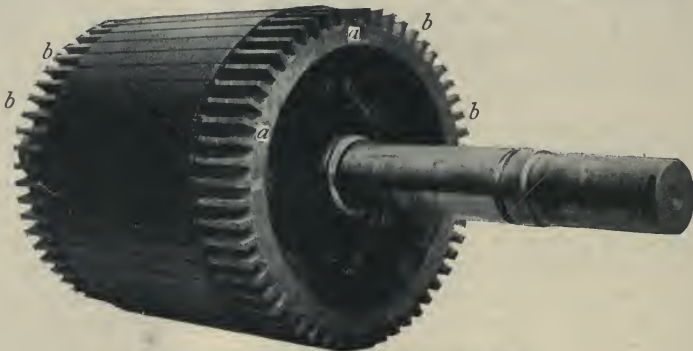

Fig. 592.—Johnson and Phillips' Squirrel Cage Rotor.

the paths which give the best mechanical effect, but to attain this we have increased the resistance of the circuits in which these currents flow without increasing the E. M. F., for any form of constraint of this kind implies an increase of resistance. We have, therefore, cut down the magnitude of the currents, and to that extent have diminished the mechanical torque. A glance at Fig. 591 suggests a further improvement. Let the laminated iron protrude through the slots so as to improve further the magnetic

circuit ; the flux will be thereby made very much denser, the induced E. M. F.'s will be increased, and the currents raised to a greater magnitude than in the unslotted cylinder. There is now, constructionally, no further need to keep to the slotted cylinder ; the copper may be in rods lying in slots in the iron, and the end connections may consist of copper rings firmly connected to the rods. We thus arrive at the finished squirrel cage rotor, shown in Fig. 592, which is produced from a photograph of an actual rotor built by Messrs. Johnson and Phillips. The solid copper bars *bb* of rectangular section are nearly buried in the iron, which not only protrudes through the gaps between them, but closes over them in front, and leaves only a very narrow gap on the surface of the rotor. The iron carcass, before the copper bars are inserted, is illustrated separately in Fig. 593, which clearly shows the form of the slots. The bars are sweated into massive copper rings *aa* (Fig. 592) at each end, thus completing the "squirrel cage." The driving spider, which transmits the torque from the iron core to the shaft, can be well seen in Fig. 593.

We have now shown that the squirrel cage rotor may be re-

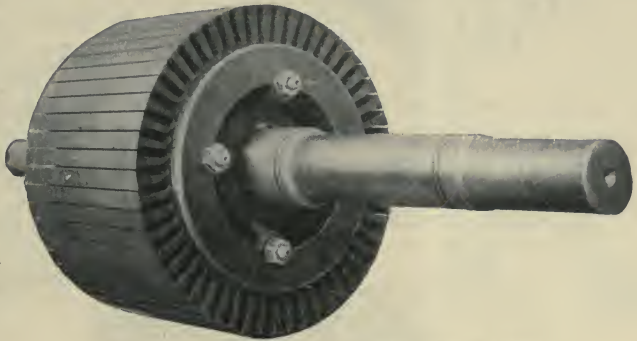

Fig. 593.—Iron Core, Driving Spider and Shaft of Rotor.

garded as an Arago disc modified and developed in the light of subsequent discoveries. But having introduced the principle of constraint into the conducting circuits of the rotor we may carry that principle much further than the squirrel cage, by designing the windings of the rotor as carefully as the windings of the armature of a generator, and so disposing them as to produce the best effect under given conditions of working. Thus we may have a series of quite separate and distinct short-circuited coils, or we may have star or mesh grouped windings with their ends brought out to slip-rings, so that we can at will introduce resistance, inductance, or capacity into the circuits. In Fig. 594 we give a diagram, due to Dr. S. P. Thompson, of a drum-wound rotor placed inside a tri-phase ring-wound stator. The windings of the rotor circuits are connected in four separate groups, the wires of each group being bunched at intervals of  $120^\circ$  apart on the drum. Each group may, therefore, be regarded as a separate system, symmetrically arranged for induction by the tri-phase stator, and as the relative

positions of maximum magnetic flux and conductors change, owing to want of synchronism between the rotating-field and the revolving rotor, there will always be one group not far from the position for best effect.

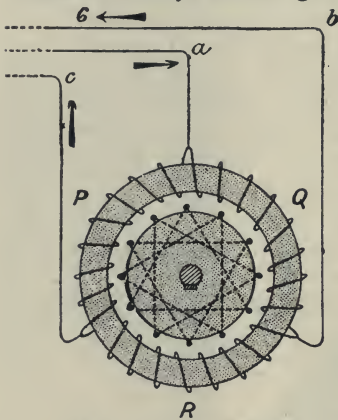

Fig. 594.—Drum-Wound Rotor.

In Fig. 595 we illustrate an actual wound rotor, constructed by Messrs. Johnson and Phillips, which has an outside diameter of 13 inches and a core 6 inches wide. It is wound for a six-pole stator field, and the ends of the windings are brought to the three slip-rings shown on the axle, where they may be either short-circuited or otherwise dealt with as indicated above. The stator is to be supplied with a two-phase current at 220 volts and 50 periods per second. In this field the rotor gives 15 B.H.P. when fully loaded, and runs at 960 revolutions per minute, the slip therefore being 4 per cent.

To illustrate the application of these principles we shall conclude this section by describing briefly one or two actual machines, and shall reserve further technical details to a subsequent chapter.

In Fig. 596 are shown the parts of an induction motor constructed

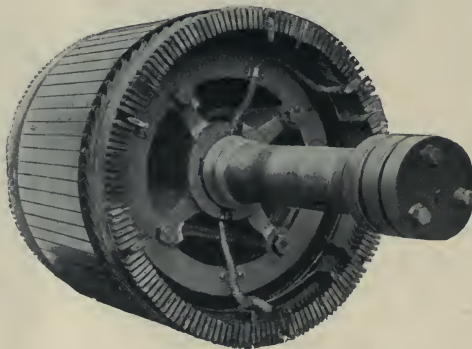

Fig. 595.—Wound Rotor with Slip Rings.

by the International Electrical Engineering Company. On the left-hand side is the rotor wound much in the same way as the armature of a three-phase alternator, the ends of the windings being brought to three slip-rings on the axle, which, however, in this case, are only used when the machine is starting, for when full speed is attained they are short-circuited. In the centre is the stator, which consists of a cast-



iron yoke, from which the laminated core projects inwards. The plates of the core are pierced longitudinally with holes, which are very nearly closed on the inner face, and through which the current-carrying coils are wound. There are twenty-one of these coils, or seven to each phase; and these, when supplied with three-phase currents, will give a rotating field of fourteen poles. The revolutions ( $n_1$ ) per minute of this field will be given by the equation—

$$n_1 = \frac{60n}{P} = \frac{60}{7}n$$

where  $P$  is the number of *pairs* of poles in the stator and  $n$  is the

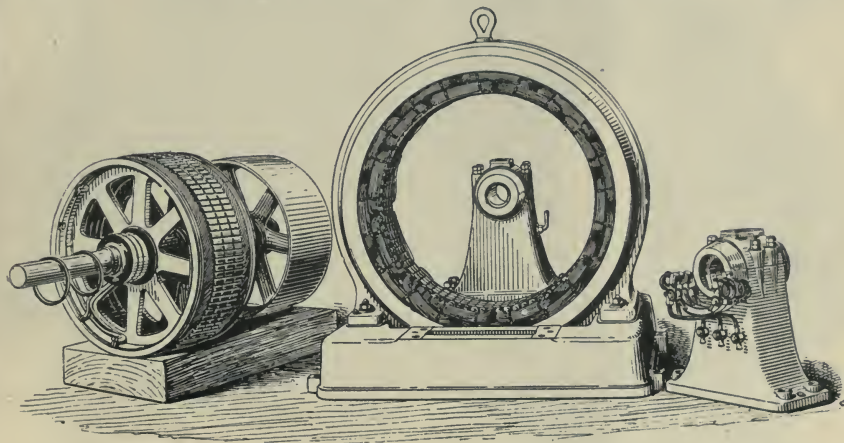

Fig. 596.—Rotor, Stator, and other parts of an Induction Motor.

number of periods per second of the current supplied. The full speed of the rotor will be about 3 to 8 per cent. less than the speed of revolution of the rotating-field.

The front pedestal of the machine is shown separately on the right-hand side. It carries the three terminals to which the leads of the starting resistances are to be attached (through a proper starting switch), and also the brush gear for making connections to the slip-rings. Each ring has two carbon brushes bearing on it, one on either side; the general arrangement being neat and compact.

The machine illustrated has an output of 125 brake horse-power at full load, and runs at about 410 r.p.m. (revolutions per minute) on a circuit of a periodicity of 50  $\nu$ . The bearings are self-lubricating, with the usual lubricating rings, shown loose on the shaft in Fig. 596, and require little or no attention when running. It should be noticed that the yoke casting is deeply flanged, a method of design which not

only improves the appearance of the machine, but also, to some extent, shields the stator windings from injury.

The stator of a 150 horse-power induction motor of the Westinghouse Electric Company is illustrated in Fig. 597, whilst Fig. 598 shows the complete machine mounted on its slide rails, with the pulley for driving machinery supported by a third bearing. As before, the stator (Fig. 597) consists of a heavy cast-iron yoke, on which the internal laminated and

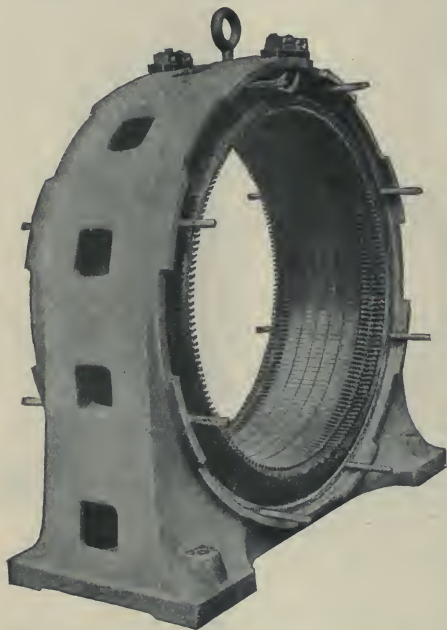

Fig. 597.—Stator of Westinghouse Poly-phase Induction Motor.

slotted ring of sheet steel is built. As shown, the finished stator strongly resembles the armature of a generator. The windings are divided into the requisite number of sections for the poly-phase currents which are to be used. There are no slip rings on the rotor, which is of the squirrel cage type, and the machine is started by reducing the voltage on its terminals until the normal running speed is nearly reached. Full details of the methods of starting induction motors will be given subsequently. The rotor bearings proper are carried by massive spiders bolted to the yoke ring, and having their open parts filled in with perforated iron shields, thus completely protecting the internal parts from mechanical injury. The motor illustrated runs at 480 r. p. m. on circuits, with a periodicity of 25  $\sim$ , and at

575 on circuits of 30  $\sim$ . These figures indicate that the slip allowed is 4 per cent. with a six-pole rotating magnetic field. The machine weighs 14,250 lbs. as illustrated, but only 9,700 lbs. without the pulley and extra bearing.

**Mono-phase Induction Motors.**—The most successful mono-phase alternate current motors belong also to the induction class, in which the conductors on the moving part are not connected to the supply circuits, nor do they directly receive any current from those circuits. The currents in these moving conductors are generated, as in the rotors just described, by inductive actions within the machine itself; and, by the interaction of the consequent magnetic fluxes with the fluxes set up in the stationary part, energy is transformed and mechanical work done.



Fig. 598.—Westinghouse Poly-phase Induction Motor.

That mechanical forces of considerable magnitude may be set up by such interaction of magnetic fluxes caused by mono-phase currents, can be shown by some fairly simple experiments, which we owe to Prof. Elihu Thomson. Let a copper ring  $R$  (Fig. 599) be held just above the pole of an electro-magnet  $M$ , through the coils of which alternate currents are flowing; it will be found that the ring is repelled from the pole of the magnet, and tends to move off, as shown by the position of the dotted ring. At first sight it is not very apparent why this repulsion should take place. It is true that whilst the magnetic field is increasing the induced currents, as we have previously seen (page 418), are such as to cause repulsion; but then as the field decreases the inductions are in the opposite direction, and cause attraction. It would appear, therefore, that on the whole the two sets of forces should balance. That



this is not so is due to the *inductance* of the ring, and its effect upon the *phase* of the currents, which we have fully discussed (pages 537 to 548).

This effect is shown graphically in the curves of Fig. 600, which are drawn according to the rules previously explained. The thick line curve

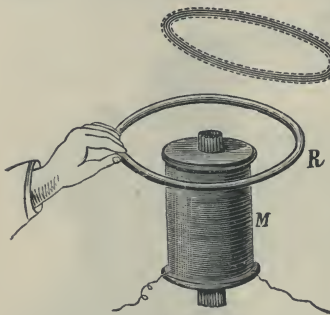

Fig. 599.—Copper Ring held over an Alternate Current Magnet.

O A B D shows rather more than one complete alternation of the magnetic flux from the magnet M (Fig. 599). This flux passing through the ring induces E. M. F.'s which are — when the flux is increasing, + when it is diminishing, and zero at the + and — maxima of the flux. These variations are shown by the fine line curve *n a b d*, which, it will be observed, lags a  $\frac{1}{4}$ -period in *phase*\* behind the curve for the magnetic flux. This, then, is the curve for the E. M. F. impressed on the ring. But, as we have

seen, if there be inductance the *current* in the ring, and therefore the *magnetic field* due to that current, will lag behind the impressed E. M. F., and in consequence must be represented by some curve such as the dotted line *n' a' b' d'*, whose phase is behind that of the curve *n a b d*.

Now the mechanical forces are due to the interaction of the fluxes

O A B D and *n' a' b' d'*; when these fluxes are in the same direction there is attraction, when in opposite directions there is repulsion. In the intervals

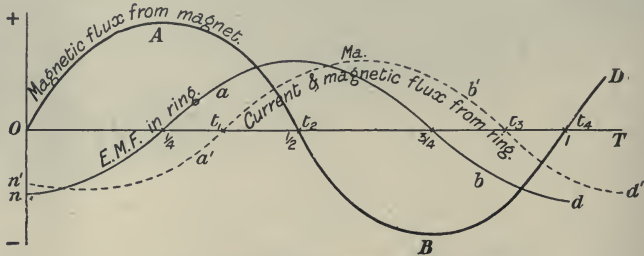

Fig. 600.—Effect of the Inductance of the Ring.

from 0 to  $t_1$  and from  $t_2$  to  $t_3$  they are opposed, and we have repulsion, whilst in the shorter intervals from  $t_1$  to  $t_2$  and from  $t_3$  to  $t_4$  they are in the same direction, and we have attraction. Moreover, the instantaneous forces are proportional to the products of the fluxes at each instant, and an examination of the diagram will show that not only are the periods of repulsion of longer duration than the periods of attraction, but that also the forces of repulsion are, on the average, greater than the forces of attraction. On both grounds, therefore, the sum of the repulsions overbalances the sum of the attractions, and the ring is repelled.

The repulsion can be shown very strikingly by tethering the ring to the

\* See page 541.

table as in Fig. 601, when, with a powerful electro-magnet, the heavy copper ring will be lifted bodily from the pole, and, as it were, float in air above the pole. In both experiments the copper ring is quickly heated up by the large induction currents generated in it.

Not only will the ring be repelled bodily from the magnet, it will also tend to turn and set its plane along the lines of the magnetic flux from the electro-magnet, except in the case in which it is so accurately at right angles to that flux that its axis absolutely coincides with the axis of the flux. In this case it will be, as regards turning, in unstable equilibrium. The experiment can best be made by turning the magnet into the horizontal position as in Fig. 602, and hanging the ring in front of it. If hung by a bi-filar or torsional suspension it will be found that the ring will take up a position inclined to the axis, and that in this position a permanent torque or turning moment is exerted on it.

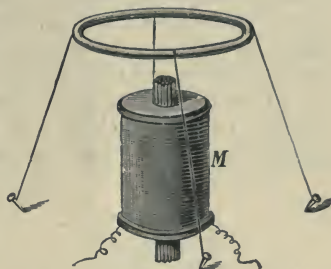

Fig. 601.—Copper Ring floating above an Alternate Current Magnet.

Advantage was taken by Prof. Elihu Thomson of the permanent torque in the oblique position to produce a single-phase induction motor. He placed in the bi-polar field of an ironclad dynamo (Figs. 603 and 604) an open coil armature wound with three coils, whose ends were brought to a six-part commutator. Two brushes joined by a short-circuiting wire were placed diametrically opposite one another on this commutator in such a position that they short-circuited the coil with which they made contact during the period of the rotation when the coil was in the best position for the production of the magnetic torque between the magnetic flux of the currents induced in it and the magnetic flux of the field magnets. In other positions the circuits of the coils were not closed, and no currents were induced. The field magnets were laminated, and were excited with alternate currents, and as each armature coil swung into the short-circuiting position the requisite currents were induced in it, and the motion was maintained. With this machine a fair amount of power was developed. It is worth noticing how the magnetising coils of these field magnets encircle the armature, as in Forbes' dynamo (Fig. 477); the experiment would, however, be successful with the coils in any other of the usual positions.

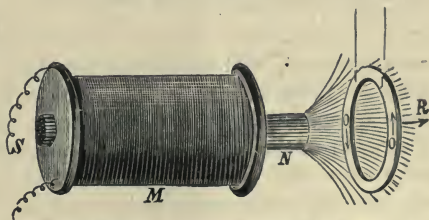

Fig. 602.—Permanent torque exerted on Copper Ring.

The same principle has since been applied to an ordinary Gramme ring armature in the bi-polar field of an alternate current electro-magnet.

In this case the short-circuiting brushes were placed obliquely in such a position that the currents induced in the ring gave the best mechanical effect. These currents were compelled to flow in the circuit provided by the short-circuit across the brushes, which were so placed that a strong torque was produced between the flux set up by the field magnets and the flux set up by the currents induced in the ring. The ring, therefore, rotated, but as it moved round the fixed brushes maintained the induced flux in the same position, and the torque continued. Consequently the speed increased until the torque produced was balanced by the resisting torque due to friction and to the useful load put on this "repulsion" motor.

In many mono-phase motors a short-circuited rotor winding is used similar to those which we have described in connection with poly-phase machines. Such a machine, when once the proper speed has

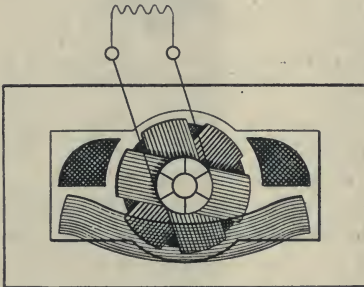

Fig. 603.—Thomson's Mono-phase Induction Motor.

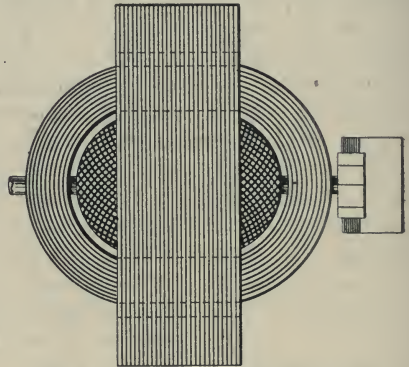

Fig. 604.—Plan of Mono-phase Induction Motor.

been attained, will absorb power from an alternate (*i.e.* not a *rotating*) magnetic field, but some special device is necessary to run the rotor up to synchronism, and as a rule the machine cannot start with the load on. The device usually employed, and known as, *splitting the phase*, is to have two sets of windings on the stator, and to put these in parallel for starting with extra inductance in one circuit to produce a phase-difference between them. If the two sets of coils are properly spaced round the stator the currents in them will produce a rotating magnetic flux, but as a rule the speed of rotation will not be uniform during a complete revolution, but will be more or less jerky. When the rotor has fallen into step the extra set of coils is cut out of circuit, and the machine then runs as a *synchronous mono-phase induction* motor.

We postpone further discussion of details, and of machines developed within the last few years, and shall conclude with a reference to a machine of historical interest, designed by Tesla, in which a rotating magnetic field produced as above described was used for working



purposes, and not for starting only. Of this machine Fig. 605 is a diagrammatic end elevation, and Fig. 606 is a longitudinal elevation, partly in section. The frame A which formed the field magnets or stator was built up of sheets of iron stamped out to the required shape and bolted together, with slight insulation between them. The magnet had eight poles projecting inwards, four B B B B at one end of the armature and four C C C C at the other. The terminals of the motors were at  $T_1$  and  $T_2$ , and the field-magnet coils, of which there was one on each polar projection, were joined up in two parallel groups between these points, each group being formed of all the poles at one end of the armature. The coils were so wound that if a steady current were sent from  $T_1$  to  $T_2$  the poles of each group would be alternately N and S, and thus, if both groups are considered, two N's would be followed

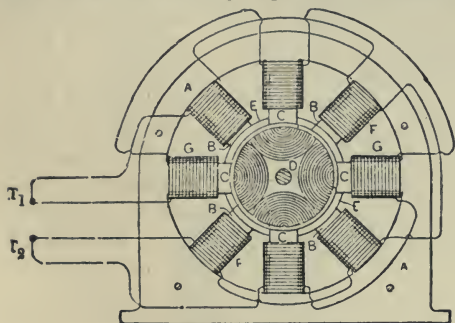

Fig. 605.—Tesla's Split-phase Motor.

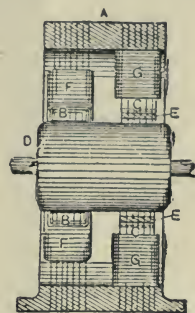

Fig. 606.—Part Section of Tesla's Motor.

by two S's, and so on. The inner poles of the c group were joined by light iron connectors, which were not used on the poles of the B group. The effect of these connecting pieces, which became saturated before the current reached its full value, was to increase the inductive reactance at the starting of a current in the c group as compared with the reactance of the B group, and thus to retard the starting or the falling of the current. If, therefore, alternate currents were supplied to  $T_1$  and  $T_2$ , the polarity of the B poles rose more rapidly than that of the c poles, but the latter persisted longer. The result was that four effective poles, two N's and two S's, followed one another round and round the periphery of the armature. The short-circuited rotor shown in the diagram (Fig. 605) had a four-coil drum winding, in which it is evident that currents would be induced which would set the rotor in rotation.

## CHAPTER XVII.

*KINETIC TRANSFORMERS.*

To complete the list of apparatus required in modern systems for the transmission of power we require yet to describe the coupled plants, the motor generators, and the rotary converters enumerated in the list of available transformers at page 575. As all these contain revolving parts, they may be referred to conveniently as "Kinetic Transformers," in contradistinction to the "Static Transformers" of Chapter XI., in which all the parts are stationary. Following the order already adopted, we have first :—

**Coupled Motors and Dynamos.**—Motors and dynamos have been separately described in the preceding pages, and it is shown in Chapter XV. (*see* page 575) how they can be used as transformers. As a rule the machines run normally at the same speed, so that they can be placed end to end and their shafts connected together by some kind of flexible coupling. Where, however, the machines have to be run at different speeds they must be mechanically coupled together by a belt or some form of gearing. In practice the sets may be required :—

- (a) To transform continuous currents at one pressure into continuous currents at another (higher or lower) pressure.
- (b) To transform alternate currents into continuous currents, either at the equivalent or a different pressure.
- (c) To transform continuous currents into alternate currents at the equivalent or a different pressure.

(a) As an example of continuous current transformation we show in Fig. 607 a motor and two dynamos mounted on the same bed-plate, and with the three armatures on the same shaft. The large machine in the centre is the motor, and the two smaller machines, one on either side, are the dynamos. The motor armature is 16 inches in diameter, and at full load takes a current of 45 to 50 ampères at 550 to 500 volts, the full load being, therefore, 25 kilowatts, or 33 horse-power. The excitation of the field magnets is such that the field increases and decreases proportionally with the fluctuating voltage, thus securing, within the limits named, that the necessary back E. M. F. shall be produced at a constant speed of 800 R. P. M. This means that the part of the magnetisation curve made use of is almost a straight line.

The dynamos are designed to give a maximum output of 10

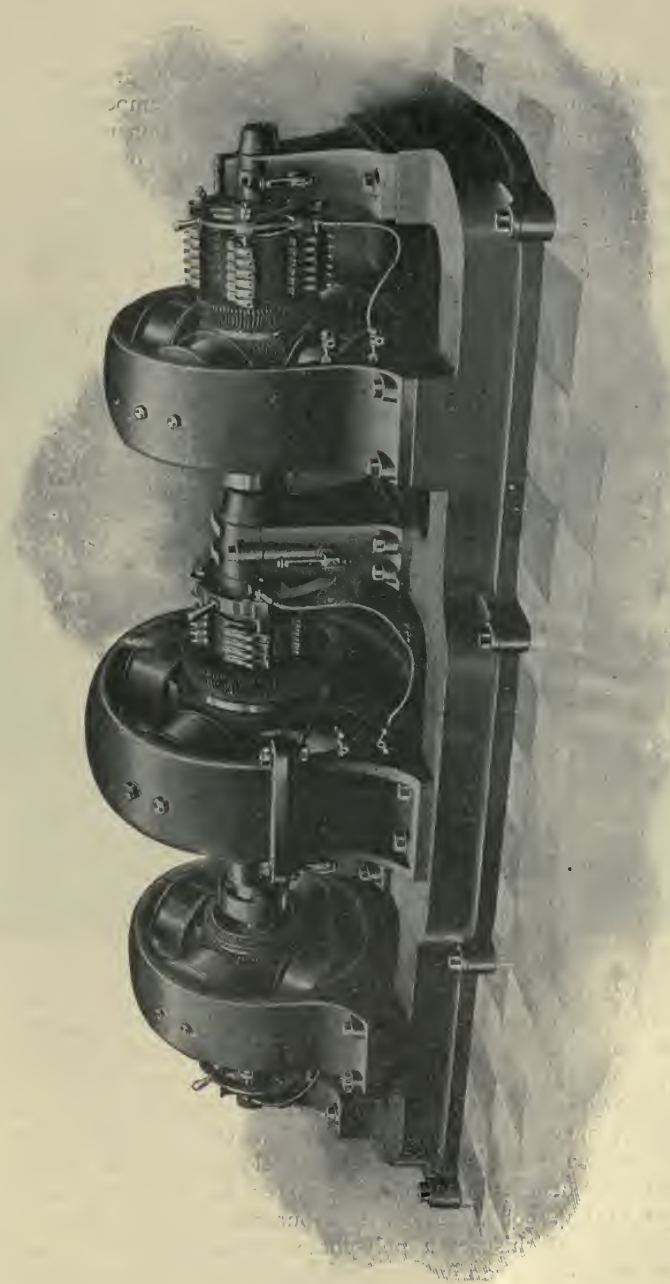

Fig. 607.—Continuous Current Transformer (C-coupled Plant)



kilowatts each, or 50 amperes at 200 volts, each armature being 12 inches in diameter. Thus the set receiving 45 amperes at 550 volts gives out electric power in the form of 100 amperes at 200 volts. As 5 kilowatts are lost in the transformation the over-all efficiency is 80 per cent. The bearings are self-lubricating, the necessary oil being stored in the four pedestals, and therefore the shaft can run for a considerable time without attention. The floor space occupied is 9 feet 8 inches by 4 feet 3 inches, and the total height is 3 feet 4 inches.

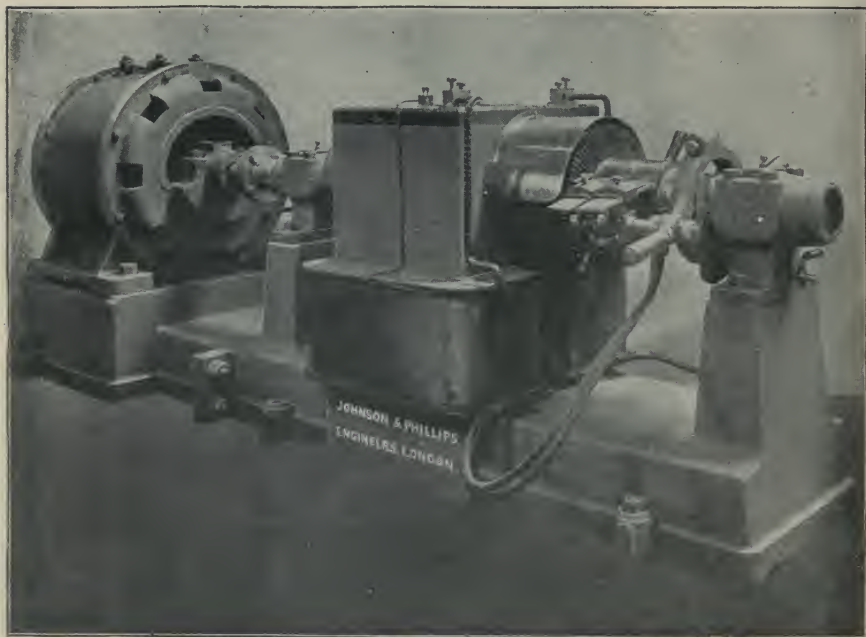

Fig. 608.—Poly-phase Motor Driving a Continuous-current Generator.

The special object of the set, which is built by the General Electric Company of London, is to take current from tramway generators whose voltage may vary rapidly, according to the demand of the tramway service, from 500 to 550 volts, and to supply current to the two sides of a three-wire lighting system at a steady pressure of 200 volts.

Turning now to the second division (*b*), in which the object of the coupled plant is to transform electric power as carried by alternate currents into the electric power of continuous currents, we illustrate in Fig. 608 a set for this purpose built by Messrs. Johnson and Phillips. In this set a poly-phase induction motor is coupled on to the shaft of a continuous-current dynamo, both machines being

carried on the same bed-plate, so as to ensure the direct alignment of the rotating shafts. The motor is intended to take two-phase currents at 220 volts, with a periodicity of 25  $\sim$ , and to develop 22.5 B. H. P. at 640 revolutions per minute. The continuous-current dynamo absorbs the power so developed, and running of necessity at the same speed generates a current of 136 amperes at 110 volts. The dynamo field magnets are shunt-wound, and are of the bi-polar over-type pattern. It behaves in every respect like the generators of a similar kind already described, and its voltage is regulated in the ordinary way for a shunt-wound generator by a resistance placed in the field-magnet circuit. The journals are self-lubricating, and the floor space occupied is 7 feet 6 inches by 2 feet 3 inches, the height being 2 feet 11 inches above the ground. The combined over-all efficiency of transformation of the plant is about 80 per cent. ; that is, the generator delivers into the continuous-current circuit about 80 per cent. of the electric power which the motor takes from the alternate-current circuit.

The arrangement of the plant for the third purpose (c), mentioned on page 628, will be understood from the descriptions already given. The transformation from continuous to alternate currents is not so often required in practice as the other two transformations.

**Motor Generators.**—These transformers, which are specially suitable for continuous currents, are variously known as "Continuous Current Transformers," "Motor Dynamos," "Dynamotors," and "Motor Generators." Referring to one of the arrangements above described, that of two continuous-current machines acting as motor and dynamo respectively, some possible modifications are obvious. If the machines have their armatures coupled together on the same shaft, each armature rotating within its own field magnets, one simplification would be to suppress one of the sets of field magnets, and to cause both armatures to rotate within the other set. This points to a further modification in which the two armature cores are combined into one, which is then wound with two entirely distinct circuits provided with separate commutators, the two circuits representing the armature circuits of the motor and dynamo of the first combination. A machine so constructed is called a "motor generator."

An early stage in such a simplification is shown on Figs. 609 and 610, which represent a machine built by the Alioth Co. In this machine the yokes only of the field magnets of two separate machines have been combined into a single yoke. Projecting inwards are two sets of six poles each on the right and left respectively (Fig. 610); each pole carries a magnetising coil. Within this magnetic system revolve the two armatures mounted side by side on the same shaft, and each provided with its own commutator and brushes. The armatures are wound with different numbers of turns, so that the back E.M.F. of the one which is used as a motor armature may have

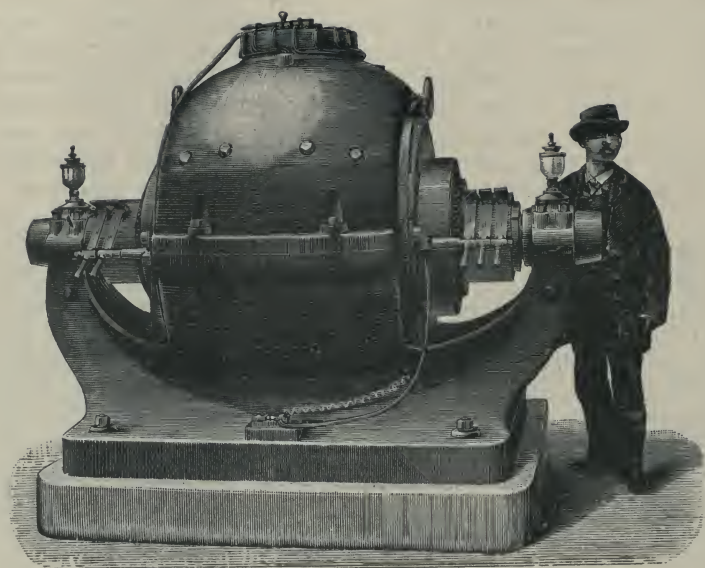

Fig. 609.—Alioth Motor Generator.

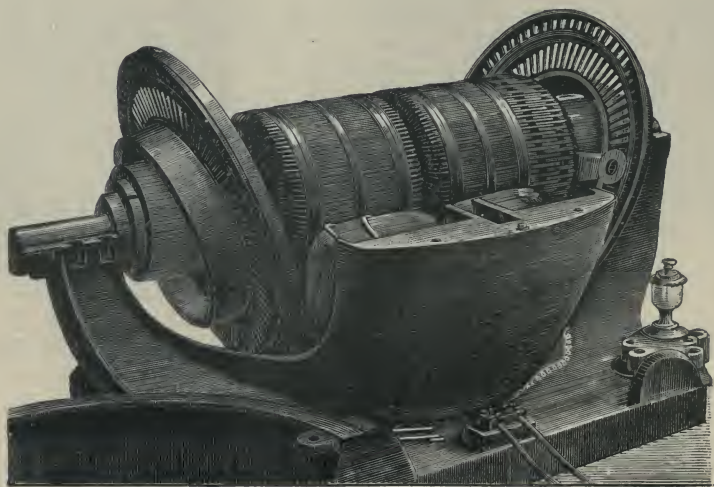

Fig. 610.—Armatures and Field Coils of Alioth Motor Generator.



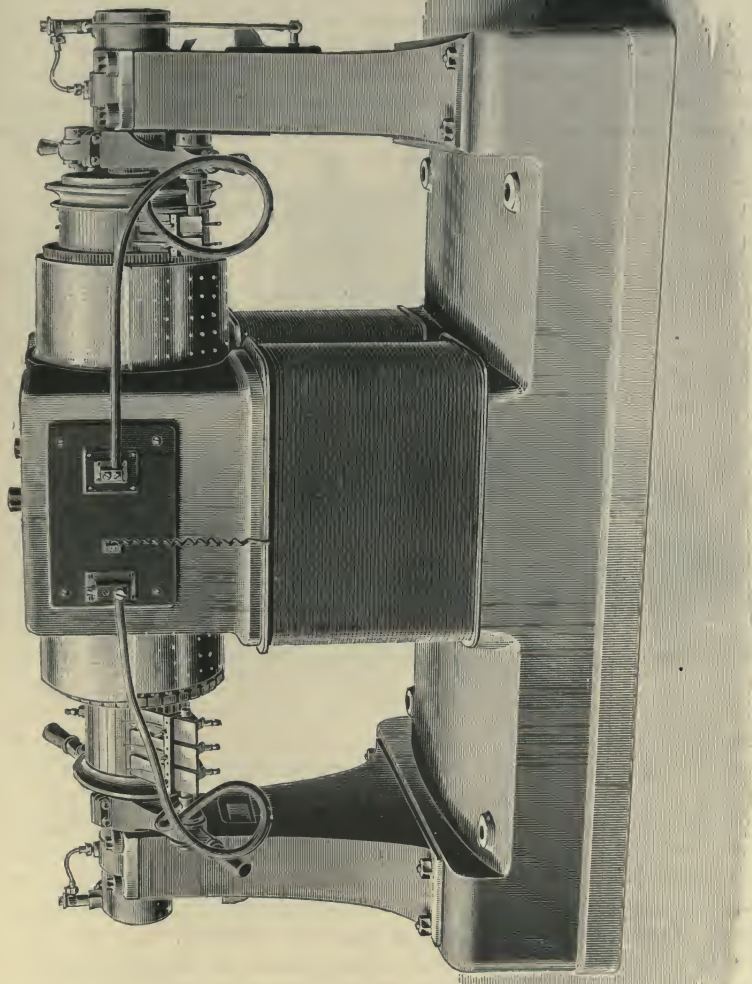

Fig 611.—Elwell Parter Motor Generator.

any desired relation to the forward E. M. F. of the other, which is used as the generator armature.

In Fig. 611 is illustrated an Elwell Parker motor generator, as made some years ago by the Electric Construction Corporation, and used at the Oxford Central Station. At first sight it might have been mistaken for an ordinary dynamo, from which, however, it differed in having a commutator at each end and in the absence of the driving pulley. The commutator at the right-hand side was for the high pressure motor circuit of the machine, which when fully loaded was intended to receive on that commutator a current of about 43 amperes at 1,000 volts. This

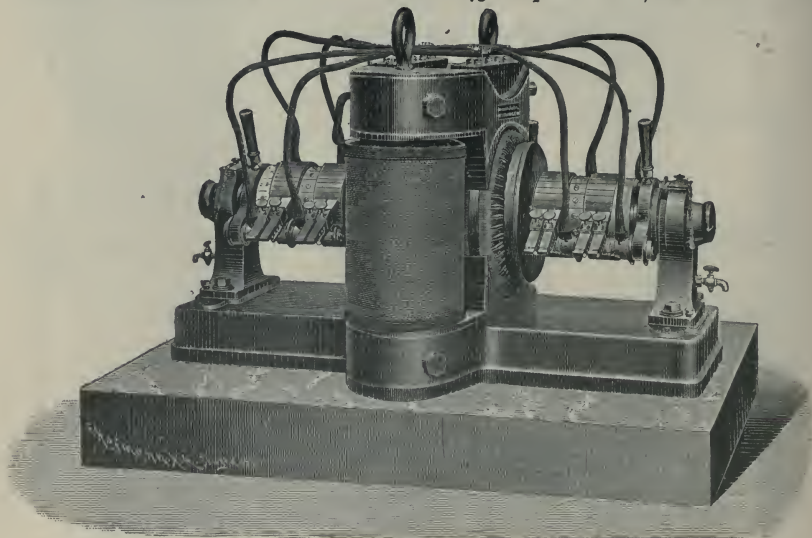

Fig. 612.—Quadruple Circuit Motor Generator.

current caused the armature to rotate at a speed of 550 revolutions per minute, at which speed there could be drawn off from the other commutator a current of 360 amperes at 110 volts. Thus the efficiency at full load was 92 per cent. In this particular machine the field magnets were first excited by the current from a secondary battery; but when the full speed had been attained a current from the low pressure commutator was used. The bearings were continuously lubricated by special oil-pumps, so that the machine required very little attention.

The considerations which govern the design of the armature and field magnets in motor generators are much the same as those which we have referred to when treating of dynamos, and it is therefore unnecessary to repeat them. In the winding of the motor dynamo armature there is, however, an additional electrical difficulty in the necessity for

good insulation between the two sets of windings, for contiguous wires belonging to the two circuits may be at very different potentials. This difficulty of efficient insulation is such that some engineers advocate the winding of the two circuits on separate armatures. There is, however, with one armature an important compensating advantage in the reduction of the armature reactions, which render sparkless commutation so difficult in dynamos. This is due to the fact that contiguous wires in the two circuits of the motor generator carry oppositely directed currents, which tend to neutralise one another's magnetic effects, thus reducing both the demagnetising and the cross-magnetising effects. In the above machine the field magnets were of the "overtone" form described at page 525.

In a more complicated motor generator, illustrated in Fig. 612, the field magnets were of the double magnetic circuit type referred to at page 521. It had no fewer than four separate circuits wound upon its armature, each circuit having its own commutator, there being two of these at each end. The machine was specially designed to act as a "compensator" on a five-wire system of distribution. The four sets of brushes were joined in series with one another, and the two outside points of the series were connected across the external wires or main feeders of the system, whilst the intermediate junctions were connected to the other three intermediate wires taken in proper order. The field magnets were excited by a shunt current drawn from the main feeders, which had a P. D. of 480 volts. If the four different sections of the system were all at the proper P. D. of 120 volts, a small current flowed through the four armature circuits, and the armature rotated. When, however, the P. D. of any section increased by 1 or 2 volts, the armature circuit connected with it received considerably more current, and the armature rotated more rapidly. As at the same time the P. D. of the other sections must have fallen, since the whole P. D. was kept at 480, these sections received current from the corresponding parts of the armature which now acted as generators. Thus the first armature circuit tended to lower the raised P. D. on its section, whilst the other three by supplying current tended to keep up the lowered P. D. on their sections. In this way the machine exercised a very effective and automatic regulation.

**Rotary Converters.**—These machines have ordinary field magnets excited by continuous currents, and influencing an armature with one system only of windings, but provided both with slip rings and a commutator, so that either alternate currents can be supplied to the machine, and continuous currents drawn from it, or *vice versa*.

The arrangement is illustrated diagrammatically in Fig. 613, which represents an ordinary Gramme-wound armature rotating in a bi-polar field. To avoid confusion the commutator has been omitted, and the brushes, *c c'*, for collecting the continuous current are shown sliding on the wires of the armature, a method of collection which is sometimes used



in practice (see page 533). Two insulated slip rings,  $s$  and  $s'$ , are mounted on the axle of the machine, and respectively connected to two diametrically opposite points,  $d$  and  $d'$ , on the armature windings; they slide under two fixed brushes  $a$  and  $a'$ ,

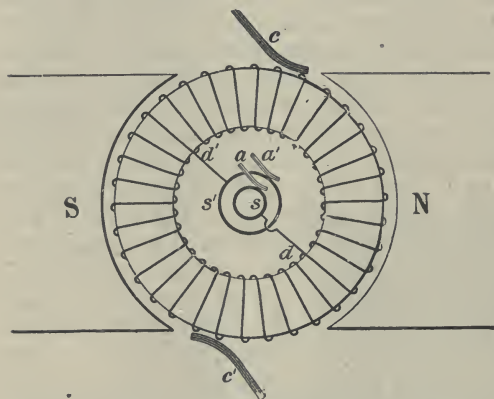

Fig. 613.—Gramme Ring Generating both Continuous and Alternate Currents at the same time.

by which connection can be obtained to an external closed circuit.

If now, the field magnets being excited, this armature be driven round by a prime mover of any kind, either a continuous current can be drawn from the brushes  $c$   $c'$ , or an alternate current from the brushes  $a$   $a'$ . As a matter of fact, however, both currents can be obtained at the same time in magnitudes depending on the electrical constants of their respective

circuits. Further, if, instead of driving the machine by an independent source of mechanical power, an appropriate motor current be supplied to either pair of brushes, a generator current of the other kind can be drawn from the other pair of brushes. In this way an alternate current can be converted into a continuous current, or a continuous current into an alternate current, the proper precautions and conditions for starting being observed on the motor side.

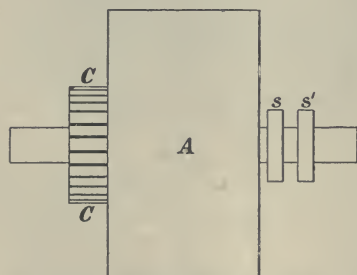

Fig. 614.—Armature with Commutator and Slip Rings.

In actual practice a commutator would be used on the continuous current side, as shown in plan in Fig. 614, where the field magnets are removed, and  $A$  represents the armature,  $c$   $c$  the commutator on one side, and  $s$   $s'$  the slip rings on the other side. Suppose, now, that the machine, having been brought up to the proper speed corresponding to the number of poles,

and the periodicity of the alternate current available, this current is supplied to the slip rings. It must be remembered, as has already been pointed out, that in all armatures, continuous or other, the induced E. M. F.'s alternate in direction in the individual windings of the armature, and that the function of the commutator in continuous-current machines is to transform the resulting alternate currents into unidirectional ones. In the case now being considered, the alternate currents passing into

the armature from the slip-rings meet the back E. M. F.'s set up by the rotation of the conductors in the magnetic field, and a motor action results by which sufficient electric energy is taken from the circuit to supply the losses due to mechanical friction, eddy currents, etc. The currents passing on through the windings are then dealt with by the commutator in the usual way, as if they had been generated by the machine itself, and pass on into the other circuit as continuous currents. It follows from this that there must be a definite relation between the

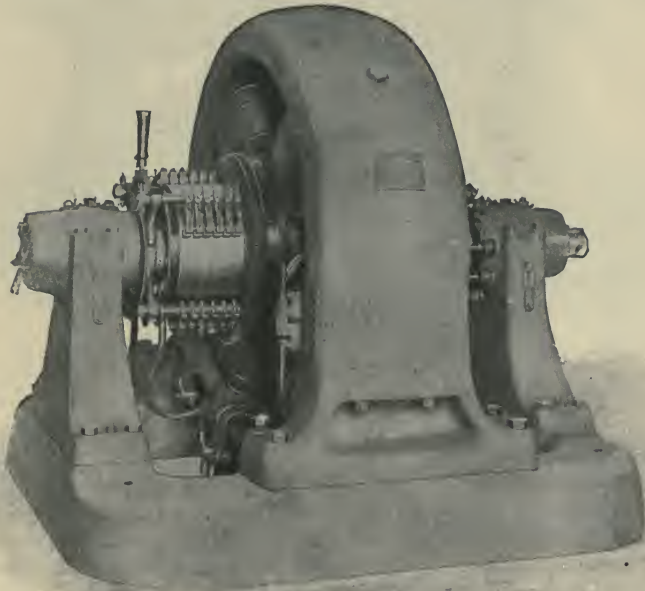

Fig. 615.—Rotary Converter (330 H.P.) Continuous-current Side.

P. D. supplied to the slip-rings and the P. D. delivered by the brushes on the continuous-current side. We shall return to this subject later.

In Figs. 613 and 614 two slip-rings only are shown on the alternate-current side, but it is obvious that by using three or more rings and connecting them to the appropriate windings on the armature the transformation could be from or to poly-phase currents of any specified kind.

An actual three-phase rotary converter, as constructed by the British Thomson-Houston Company, Limited, is shown in Figs. 615 and 616. A four-pole field magnet and a drum-wound armature are used; Fig. 615

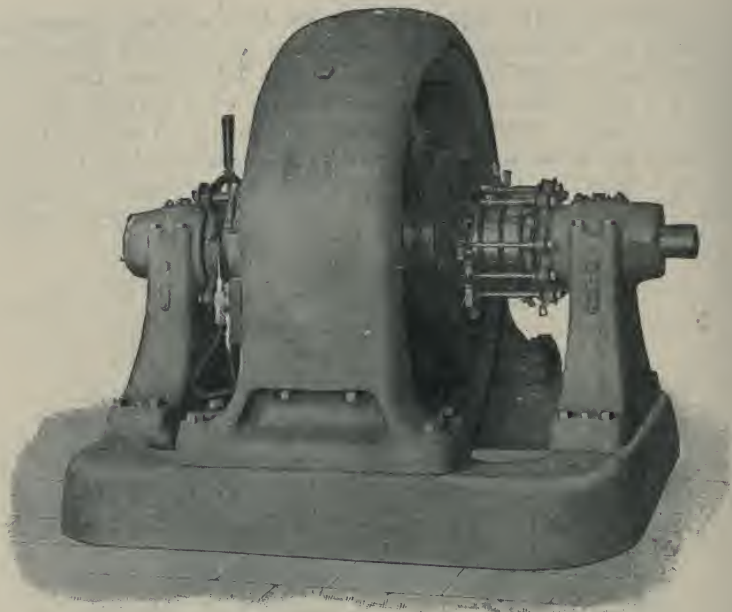

Fig. 616.—Rotary Converter (330 H.P.) Alternate-current Side.

shows the continuous-current side with its commutator and brushes, whilst Fig. 616 shows the alternate-current side with its three slip-rings, on each of which are placed three brushes. The whole construction of the machine is very similar to that of the dynamos built by the same firm. The particular converter illustrated has a capacity of 250 kilowatts (330 horse-power), and is intended to run at 750 revolutions per minute on a three-phase circuit of 25 periods per second, the same speed as that of a four-pole synchronous alternate-current motor taking energy from such a circuit. The field magnets may be either shunt or compound wound, as may be required for regulating purposes, and in the latter case this firm uses a variable resistance in parallel with the series coil for adjusting its effect. The regulation is not, however, the same as in a continuous-current generator, because of the inflexibility of the speed, and the voltage of the supply current. If the field magnets were over-excited, so far that the E.M.F. generated at the synchronous speed exceeded the P.D. of the supply mains at the brushes, the machine would cease to take energy from the latter, would drop out of step and soon stop.

One of the drawbacks of the rotary converter is the fact that the P.D. of the current sent out must bear an almost invariable ratio to



the P. D. of the current taken in. The following table, due to Dr. S. P. Thompson,\* gives the voltage ratio in various cases, and also the actual voltage on the alternate-current side, on the assumption that a continuous current at 100 volts is supplied to the brushes on the continuous-current side :—

Number of Slip-rings.	Angle between Connections to Rings.	Nature of Alternate Currents Generated.	Voltage Ratio.	A. C. Voltage (Virtual † Volts).
2	180°	Single-phase	$\frac{1}{\sqrt{2}}$	70·71
3	120°	Three-phase	$\frac{\sqrt{3}}{2\sqrt{2}}$	61·23
4	90°	As two-phase	$\frac{1}{\sqrt{2}}$	70·71
4	90°	As four-phase	$\frac{1}{2}$	50·00
6	60°	As three-phase	$\frac{\sqrt{3}}{2\sqrt{2}}$	61·23
6	60°	As six-phase	$\frac{1}{2\sqrt{2}}$	35·35

*Starting.*—As regards starting up from rest a rotary converter offers no special difficulty when it has to transform from continuous into alternate currents. In that case the continuous-current side is the motor side, and will start from rest in the same way as a continuous-current motor, the precautions, which will be explained in the technological section, as to starting resistances being observed.

When, however, the energy to be supplied is in the form of alternate currents much the same starting difficulties arise as with synchronous alternate-current motors, and it must be remembered also that the rotary cannot excite its own fields properly until it has reached the normal speed. Several methods are available. Firstly, if a continuous current of proper voltage, as for instance from other rotaries in the same station, be available, the machine may be started from the continuous-current side without difficulty. Secondly, a small coupled plant, consisting of an induction motor driving a continuous-current dynamo, may be used to take current from the alternate-current mains and to deliver a continuous current for starting purposes. One such plant with proper switching arrangements would serve a fairly large station. Another

\* Journal Institution of Electrical Engineers, vol. xxvii., page 656, 1898.

† For the explanation of this phrase see Chapter XX.

method, which is now very common, is to place a small induction motor on the shaft of the rotary as shown in Fig. 617, which represents two Westinghouse 500 kilowatt rotary converters used by the Niagara Falls Power Company in their North Tonawanda sub-station. The induction motor is carried by a bracket fixed to one of the pedestals of the large rotary; its rotor is of the squirrel-cage type, and is shown separately with

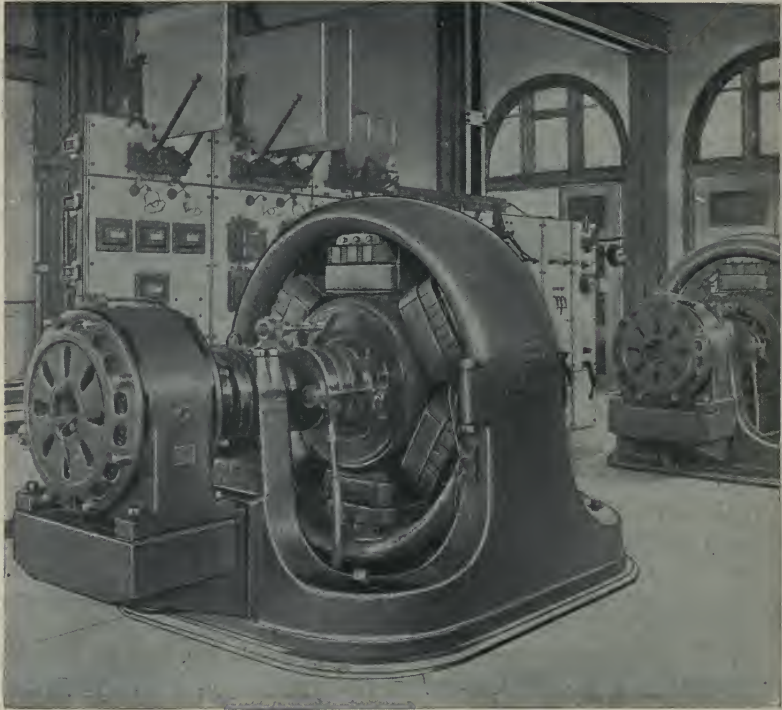

Fig. 617.—Westinghouse 500 K. W. Rotary Converters.

the shaft and armature of the large machine in Fig. 618. To start, the alternate current is first passed into the stator of the induction motor, which soon runs the shaft nearly up to the synchronous speed, and then the field-magnets can be excited, the large armature be switched on to the alternate current mains, and the current be withdrawn from the stator of the motor.

The machine illustrated takes three-phase current through a step-down static transformer from the high-pressure (22,000 volts) mains, the actual voltage on the slip-rings being varied from 305 to 335 volts by altering the circuits of the transformer. The periodicity of the supply is 25 cycles

per second, and the rotary having six poles runs at 500 revolutions per minute. The output is 500 kilowatts at voltages varying from 500 to 550 volts, according to the voltage on the slip-rings. The continuous current produced is used for tramway and power purposes in the immediate neighbourhood.

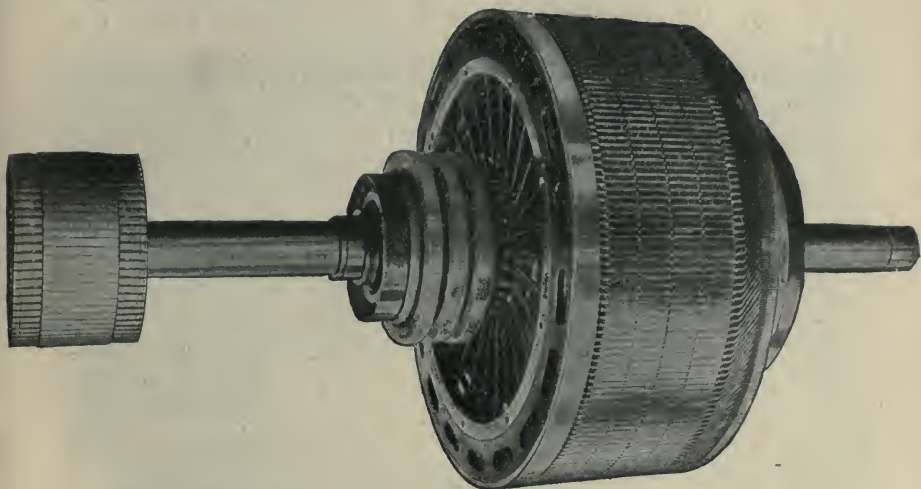

Fig. 618.—Armature of Westinghouse 500 K.W. Rotary Converter and Rotor of Starting Motor.

It has already been pointed out that machines of this type may be used as continuous-current and alternate-current generators. It is also obvious that they may be used as continuous-current motors or as synchronous alternate-current motors; and further, they can be so used as motors at the same time as they are acting as rotary converters. When used as motors either a pulley must be mounted on the shaft or there must be some other means provided for tapping off the mechanical power required.

**Motor Converters.**—More recently large machines intermediate between coupled plant and a rotary converter have been built for the conversion of alternate into continuous current energy. In the coupled plant the energy, say, of a synchronous alternate current motor is first converted into mechanical energy, which is delivered to the common shaft of the two machines, and this energy being absorbed by the armature of the continuous current generator is by it converted into continuous current energy. In a rotary converter part of the energy is transferred from the slip rings to the commutator by a motor and generator action in the common armature and part by electrical conduction, since there is conducting communication between the rings and the commutator.



The *motor converter* is intermediate. In it the alternate current energy is supplied to the stator of an induction motor with a wound rotor; the windings of the rotor are connected to the windings of the armature of a continuous current generator *on the same shaft* and from the commutator of this generator continuous current electric energy can be drawn in the usual way. The method was devised by Herren Bragstad and La Cour, and their diagram in explanation of it is given in Fig. 619. In this diagram the three coils *s* represent the three-phase windings of the stator of an induction motor and the three coils *r* the rotor windings of the machine connected in the usual way to the starting resistances  $R_a$  through the slip rings *r*. The other ends of the rotor windings are shown connected by conductors which are carried along the shaft to the conductors of the armature *G* of a bipolar generator of which *K* is the commutator and *F* represents the field magnet winding. The continuous current load is represented by *L*.

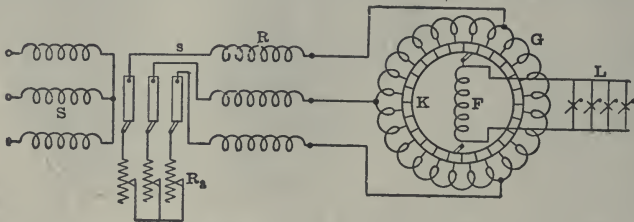

Fig. 619.—Diagram of the Connections of a Motor Converter.

Both the motor and the generator may be multipolar, suitable modifications being made in the connections. Also, instead of the rotor being wound three-phase, it may be wound with 6, 9, 12, or more phases for connection to the armature, and this modification is adopted in recent large machines.

Suppose, now, the machines to have the same number of poles and the rotor of the motor to be run at one-half the synchronous speed. The "slip" will then be 50 per cent., and alternate currents of half the periodicity of the supply current will be generated in the rotor and fed, without the intervention of slip rings in to the armature. The armature is also driven mechanically as a generator by the motor, and in the case supposed about one-half the energy absorbed by the motor will be transferred to the generator mechanically along the shaft, whilst the other half will be transferred from the stator to the rotor by electro-magnetic induction, and will be conducted by the connecting wires to the armature in which the rotary converter action will transform it into continuous current energy.

Three motor converters, each capable of dealing with 500 kilowatts, are shown in Fig. 620, installed in a sub-station at Manchester. These machines were built by Messrs. Bruce, Peebles and Co., of Edinburgh. The induction motors, with their starting resistances, are shown on the

right, and the combined continuous current generator and rotary converter on the left. The stator of the motor takes current at 6,500 volts direct from the high-pressure mains. The rotor is a little over 40 inches in diameter and has a twelve-phase winding which supplies current to the armature of the rotary converter. There are many interesting technical points in connection with these machines which will be dealt with later.

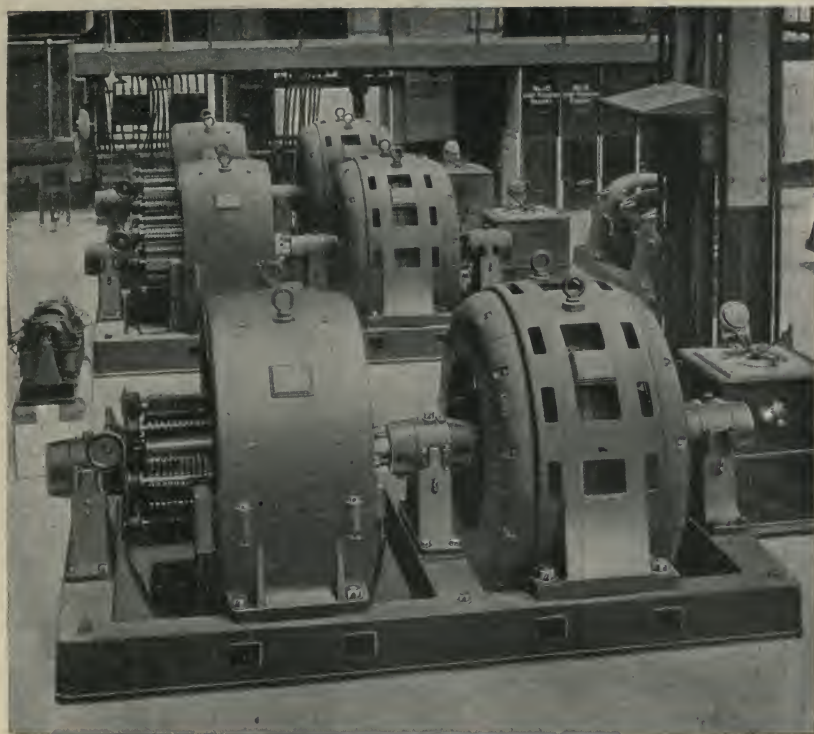

Fig. 620.—Motor Converters in use in a Sub-station.

**Permutators.**—There is still another type of kinetic transformer in which the moving parts are only a set of revolving brushes and the motor necessary to drive them. Imagine the windings of the stator of an induction motor connected to the bars of a commutator similar to that used on a continuous current machine but stationary. If now the alternate currents supplied set up a rotating field in the stator the points of maximum and minimum electric potential will similarly rotate round the commutator, and if a set of brushes can be made to rotate in step and be properly adjusted, these brushes will be maintained at a more or less

constant difference of potential and continuous or unidirectional currents can be drawn from them by means of slip rings.

This idea has been developed by MM. Rougé and Faget in France. Their machine, which is shown half in elevation and half in section in

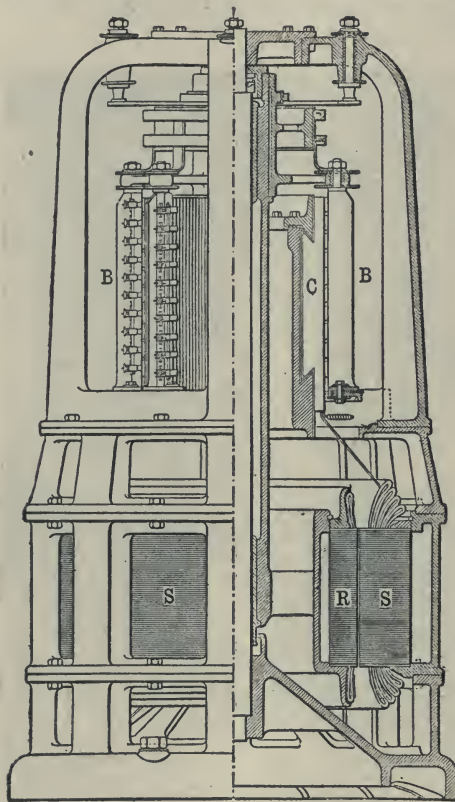

Fig. 621.—The Rougé-Faget Permutator.

Fig. 621, has a vertical spindle, which carries the rotating brushes B and the rotor R which drives them. The stator s is very similar to that of an induction motor, its windings, however, being connected as shown to the commutator bars c. The shaft passes up through the commutator, and the brushes B and slip rings are attached to spiders keyed on to the top.

The windings of the rotor are partly short-circuited and partly connected to the slip rings and, therefore, to the brushes. The first set of windings enable it to start as a short-circuited rotor of an ordinary induction motor, whilst the second set, taking current from the slip rings when synchronism is nearly attained, force the rotor up to the synchronous speed at which when attained and maintained there will be no current in the short circuited windings. The machine shown in Fig.

621 has a capacity of 150 kilowatts and runs sparklessly at all loads. As in the rotary converter, there is a definite relation between the voltage of the alternate current supplied and the voltage of the continuous current produced.



## CHAPTER XVIII.

## THE ELECTRIC DISCHARGE.

WE now return to the consideration of a most interesting branch of electrical science, with which we have already partly dealt, but the further consideration of which was postponed until the simpler properties of both continuous and alternate currents, and especially their differences, had been explained.

The group of phenomena which may be classed under the term "The Electric Discharge" is an exceedingly complex one, and takes us to the root of the question, "What is Electricity?" The main principles already ascertained are, however, not difficult to follow; and though there is much upon which modern science has not yet said the last word, a rich harvest has been gathered, and is still in process of being gleaned, with the promise of far-reaching results:

As ordinarily understood, there are two principal methods, both of which were in use during the greater part of the last century for producing an electric discharge either in air or a partial vacuum. The oldest, dating back even beyond the last century, is by means of electrical machines, especially of the influence type. The other is by the use of induction coils, which were usually of the battery type. In both cases, the brilliancy and energy of the discharge are increased by the use of condensers (*see* page 109), either of the Leyden jar or other pattern; and we propose to consider first, therefore, a little more closely the nature of the discharge from such so-called condensers.

## I.—NATURE OF THE DISCHARGE FROM A CONDENSER.

The view of the physical action of condensers which has been placed before the reader in the preceding pages (*see* page 109 *et seq.*), is that they are storers of energy in the electrostatic form, this energy being stored in the dielectric, which is thrown into a state of strain when the condenser is charged. As regards many of the associated phenomena—including those of release or discharge—the strained dielectric acts like a mechanically strained piece of elastic material, such as the steel strip *s* in Fig. 622. In this diagram the strip is represented as resting on a horizontal table, and clamped firmly at one end between the clamps *c c*; at the other end it carries a weight *w*, which also rests on the table. When unstrained the

strip is straight and lies along the dotted line  $U$ . If now the weight  $w$  be drawn to one side as shown, the steel strip is bent, strain-energy being stored in it. If the weight  $w$  be released the strip will regain its original position  $U$  in one of two ways: either (i.), if the table be very smooth, it will oscillate about  $U$  several times, more or fewer, like a swinging pendulum, or (ii.) if the frictional resistance on the surface of the table be sufficiently great, it will move slowly to its position of rest without overshooting it, and therefore without oscillation. In both cases, the strain-energy of the spring before release is eventually used up in frictional heat, generated by the rubbing of the weight on the table; but in the first case this energy oscillates between strain-energy in the spring when the spring is at rest at the ends of its swing, and kinetic energy in the weight as the spring passes the position  $U$ , whilst at each oscillation some of the energy is converted into heat by friction.

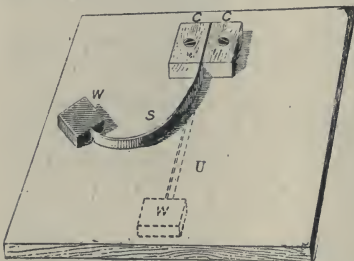

Fig. 622.—Weight Vibrating on a Horizontal Surface.

**Electric Oscillations.**—As long ago as 1842 Professor Henry, during his experiments on self-induction, observed that under certain circumstances the discharge of a condenser is oscillatory. Independently, in 1855, and as the result of a mathematical investigation, Lord Kelvin, then Professor Thomson, predicted that the discharge would be found to be either

uni-directional or oscillatory, according as the resistance  $R$  of the discharging circuit is above or below a certain critical value, depending on the other constants of the apparatus: The critical value occurs when

$$R = \sqrt{\frac{4L}{K}}$$

where  $K$  is the capacity of the condenser and  $L$  the inductance of the discharging circuit. If  $R$  be above this value, then the discharge is uni-directional, and is similar to case (ii.) of the bent spring (Fig. 622); whilst if  $R$  be below the critical value, the discharge is oscillatory and resembles case (i.).

To explain this latter case physically, we may suppose that when the jar is discharged through a wire of low resistance the strain is so rapidly removed that the dielectric, in the act of taking up its unstrained condition, swings past the neutral point and for a moment assumes, but to a less extent, a strain in the opposite direction, the jar being therefore negatively charged. This reversed charge is then discharged, the strain is again reversed, and so on. Another and better explanation is that since the discharging circuit sets up magnetic strains in the surrounding medium, and the current is at a maximum, except for phase lag, at the moment when the

jar is discharged or unstrained, the strain-energy oscillates between the electrostatic form in the dielectric of the condenser, and the electro-magnetic form in the medium surrounding the discharging circuit; whilst during each oscillation a certain fraction of the energy available is converted frictionally into heat by the resistance of the wire. The periodic time  $\tau$  of the oscillations is given by the equation

$$\tau = \frac{2\pi}{\sqrt{\frac{1}{K L} - \frac{R^2}{4L^2}}}$$

If in any given case  $K$  and  $L$  be constant and  $R$  be gradually increased,  $\tau$  will get longer and longer until at the critical value the denominator vanishes and  $\tau$  becomes infinite. An important special case occurs when the resistance  $R$  is so small that the second term in the denominator becomes negligible in comparison with the first term. The equation for the periodic time then becomes

$$\tau = 2\pi \sqrt{K L}$$

As an example we may suppose  $K$  to be 1 microfarad ( $= 10^{-6}$  farad) and  $L$  to be 10 millihenries ( $= 10^{-3}$  henry), in which case

$$\tau = \frac{2\pi}{10^4} = .00063$$

or less than one-thousandth of a second.

The phenomena predicted by Lord Kelvin, and subsequently by Kirchhoff and Helmholtz, have been experimentally examined by Feddersen, Schiller, Wullner, Blaserna and others, and the predictions have been completely verified. By using a swinging pendulum to close and open the necessary contacts, Feddersen was able to arrest the discharge at any predetermined short interval of time after it had started. He thus obtained the data to plot the curve, showing the history of the discharge, and to examine how nearly this curve expressed the predictions of theory not only qualitatively, but also quantitatively. Feddersen further showed that as the resistance is increased the discharge ceases to be oscillatory, and becomes continuous with an appreciable duration: With still higher resistances the discharge, examined with a rotating mirror, consisted of intermittent sparks, which were all in the same direction, the later ones being due to "residual charge" (see page 125).

Towards the end of the last century striking experiments on Leyden jar and condenser discharges were made with vacuum tubes by Professor (now Sir) J. J. Thomson in England and Professor Elihu Thomson and Mr. Nikola Tesla in America. As we shall explain presently (page 671), the presence of an electric current under certain conditions in one of these tubes renders it luminous. Fig. 623 illustrates one of the experiments made by Sir J. J. Thomson. A glass tube  $ACCA'$  coiled into a spiral and containing mercury, surrounds an exhausted bulb  $B$ . When



this spiral is made part of the discharge circuit of a Leyden jar, the bulb *B* becomes luminous during the discharge of the jar. This effect is due to induction, and to the fact that the discharge of a Leyden jar is oscillatory, consisting of gradually diminishing currents alternately in opposite directions. As these currents surge backwards and forwards in the spiral *A C C A'* induced currents are set up in the conducting space inside the exhausted bulb *B*, and these induced currents are sufficient to make the bulb glow quite perceptibly.

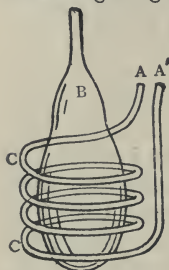

Fig. 623.—J. J. Thomson's Experiment without Electrodes.

When the account of these experiments reached America, Professor Elihu Thomson and Mr. Nikola Tesla published accounts of experiments which they had already independently made in the same direction. Fig. 624 shows an experiment made by Professor Elihu Thomson. *B* is an exhausted glass vessel having the form of an anchor ring; *J* is a Leyden jar, the inner coating of which is joined to one terminal *T* of a Holtz induction machine. The other terminal *T'* of the machine is connected to the outside of the jar by a heavily insulated wire *A A'* partly coiled underneath the exhausted vessel *B*. On working the machine it was found that at every discharge between the terminals *T T'* a band of light appeared in the vacuous ring *B*, due to the induction of the surging currents in the coiled wire beneath it.

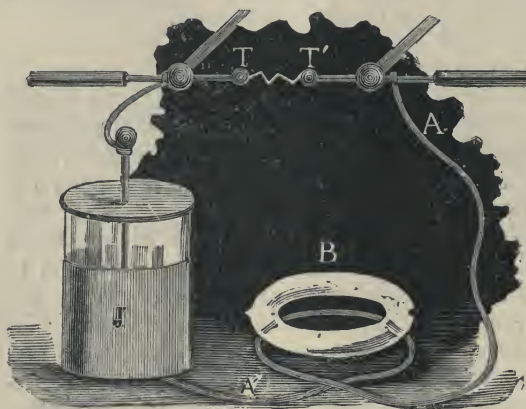

Fig. 624.—Elihu Thomson's Experiment without Electrodes.

It will be noticed that in both these experiments the vacuum tubes are without any electrodes or conductors passing through the glass, and that the effects produced are entirely due to actions propagated through the medium, consisting of air and glass.

Further and conclusive experiments on the oscillatory nature of the discharge of condensers will be described presently.

## II.—CONTACT BREAKERS OR INTERRUPTERS FOR BATTERY INDUCTION COILS:

The rapid development, during the last few years, of the practical applications of the electric discharge has led to much attention being paid to the old battery induction coil (page 427), and especially to the enhance-

ment of the disruptive effects in the secondary circuit by improvements in the form and method of breaking the battery circuit, or otherwise producing the necessary variations in the flow of the primary current. Before, therefore, describing these disruptive effects, it will be convenient to consider some of these devices, and to take up this part of the subject at the point at which it was left on page 433.

It will be remembered that the voltage inductively produced in the secondary circuit of the coil depends not on the total change of the current in the primary circuit so much as on the *rate of change* of this current. Therefore the effectiveness of the breaking arrangement or other device used for varying the primary current depends upon the *rapidity* with which any given change is accomplished.

The Nieff hammer ( $H$  in Figs. 394 and 395) has obvious drawbacks as a method of opening the contact  $B$  rapidly. A heavy mass of metal  $H$  has to be set in motion, and the natural period of vibration of this mass and the spring on which it is mounted have to be taken into account. Further, the spark which is produced at the point  $B$  as the circuit is opened tends to destroy the efficiency of the contact on re-closing, though, for reasons already given, the placing of a condenser across the gap diminishes the destructiveness of these sparks. Notwithstanding these drawbacks, however, a carefully designed and constructed Nieff hammer will hold its own against some more modern forms of contact breakers.

These modern forms, for convenience in describing them, may be classified as follows:—

- (a) Those in which the break is made in a gas (including air breaks) either at full atmospheric pressure or less.
- (b) Those in which the break is made in an insulating liquid:
- (c) Electrolytic contact breakers.

The Nieff hammer may be taken as the most widely used of the first class (a). To diminish the viciousness and destructiveness of the spark the Macfarlane Moore contact breaker has its armature and spark gap enclosed in a vacuum and operated on by an external electro-magnet. Contact breakers of this class cannot be used for long periods on coils giving sparks longer than about ten inches. The voltage in the primary should not exceed 20 volts.

In class (b) there are a great number of contact breakers. Most of them work by interrupting the circuit at the junction between a solid metal and liquid mercury, the oxidation of the latter being prevented by immersing the junction in some insulating liquid, such as alcohol or petroleum. The former has the advantage that it does not form an emulsion when the break is worked, but, being volatile, it evaporates rather rapidly, whilst the latter is less volatile, but forms an emulsion, which necessitates cleansing the mercury from time to time. In the majority of cases, the

contact breaker is worked by a small or a toy electric motor, driven either from a separate source of electric energy or from the same source from which the primary current is derived.

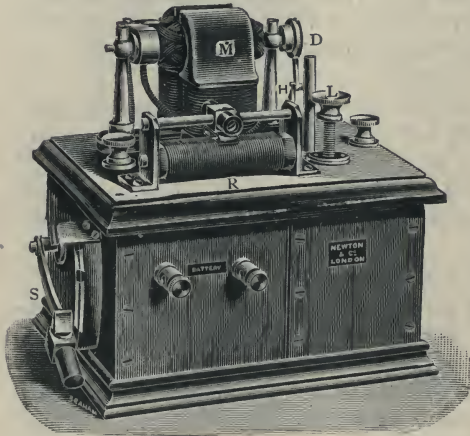

Fig. 625.—Motor-Driven Interrupter.

cally up and down: The lower part of this shaft is shown in Fig. 626, which represents a cross section of the box on which the motor stands:

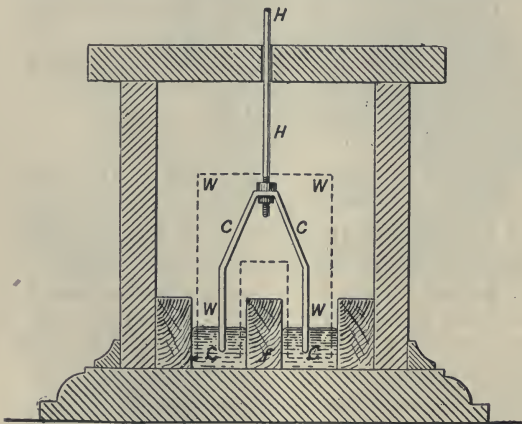

Fig. 626.—Contact Points in Interrupter.

“made” can be controlled, by raising or lowering a wooden block *w w*, shown by dotted lines, and which can be manipulated when the motor is running by means of the screw *L* (Fig. 625) on the outside of the box:

A circuit breaker (made by the same firm) for use with alternate currents

A good pattern of such a motor circuit breaker for continuous currents, as made by Messrs. Newton and Co., is shown in Fig. 625. We have dealt so fully with electric motors that we need only explain that the motor *M* is series wound for the voltage to be used, and has its current controlled by the resistance *R*, *s* being the motor switch. The shaft of the motor rotates a disc *D*, a crank-pin on which, by means of an ivory connecting rod, moves a shaft *H* vertically

The bottom part of the box is divided by a wooden fillet *f* into two troughs, each containing mercury to the same level. The break in the primary circuit occurs between these troughs, and the current is made or broken according as the ends of the copper spanner *c c c c* carried by *H* are or are not simultaneously dipping into the mercury: The level of the mercury can be adjusted, and therefore the length of time that the primary circuit is



is shown in Fig. 627. The motor has a bipolar laminated stator and a shuttle wound rotor with a split ring commutator. These are connected in series, and when the speed of the motor is the same as the periodicity of the supply circuits, the contacts of the rotor change over at the same instant as the reversal of the current: The polarity of the rotor, therefore, remains unchanged, and we have a synchronous motor which is self-starting, with currents induced in the iron of the rotor. The motor can also run well at one-half or one-quarter the speed of synchronism, the change of the rotor contacts being always made as its poles pass the poles of the stator. This motor drives two "dippers," each similar to that shown in Fig. 626, and one at each end of the shaft. These can be so adjusted that when running at half speed one break is obtained in every complete alternation.

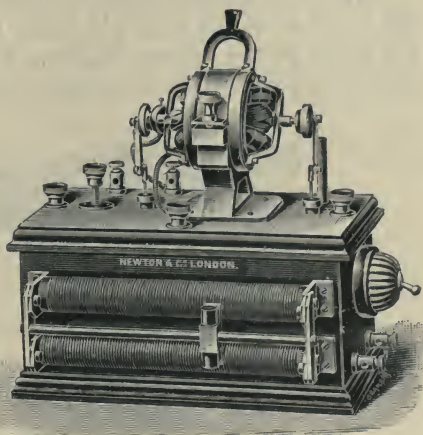

Fig. 627.—Interrupter Driven by an Alternate Current Motor.

An induction coil will, of course, work with alternate currents, being merely a static transformer, but for certain purposes, as we shall see presently, it is desirable that the discharge from the secondary terminals should be unidirectional. This can only be obtained with a pulsating current in which the rise is gradual and the fall abrupt or *vice versa*. The above contact breaker can be so adjusted that the circuit is closed for a

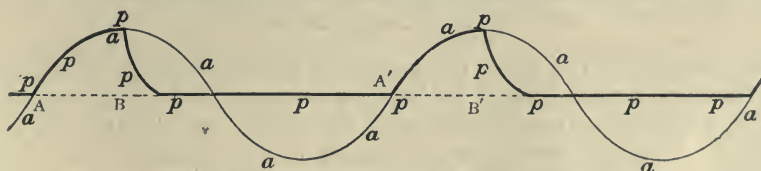

Fig. 628.—Wave Form in Primary Circuit of Coil.

quarter period only, say during the rise of the  $\frac{1}{2}$ <sup>nd</sup> current from A to B (Fig. 628). At B the circuit is sharply broken, and the current abruptly falls and remains at zero until the circuit is made again at A'. Thus the alternate current wave *a a a a* shown by the fine line is converted into the pulsating current wave shown by the thick line *p p p p*. The rapid fall or break combined with a sufficient length of spark-gap in the secondary circuit gives the desired unidirectional discharge.

In other forms of contact breakers of this type—the Mackenzie-Davidson, for instance—a motor-driven revolving blade dips into and makes contact with mercury during a part of its revolution. A sliding contact on the revolving shaft completes the circuit, and the number of breaks per second can be controlled by regulating the speed of the driving motor.

In all these forms of dipping contact breakers it may happen that when the motor stops the dipper is in the mercury, and the primary circuit is left closed at the contact breaker. Serious consequences may sometimes ensue, especially when the primary current is being drawn from electric

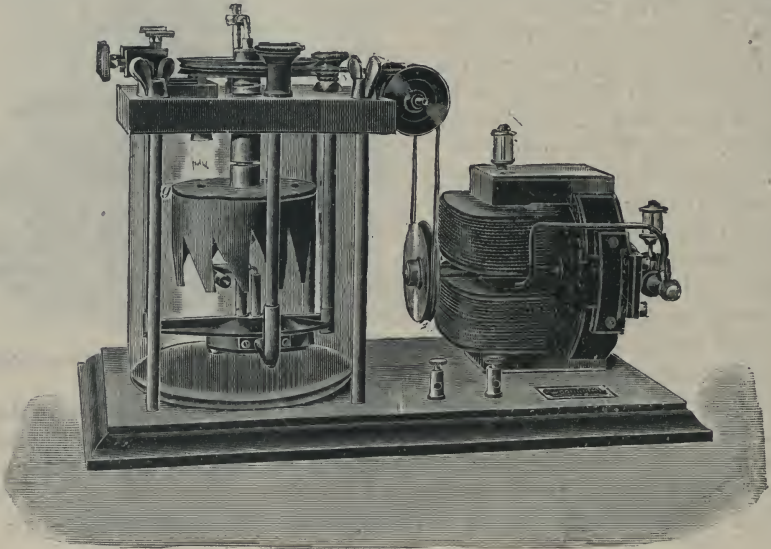

Fig 629.—Mercury Jet Interrupter.

lighting circuits. The evil is easily guarded against by properly designing the switching arrangements so that it shall be impossible to break the motor circuit without simultaneously breaking the primary circuit. It is further desirable that, when starting up, the motor for the contact breaker should receive current first, and that the primary circuit should not be closed until the motor is driving the contact breaker at a proper speed. This also can be easily arranged.

A form of interrupter which automatically avoids the above difficulty is the "mercury jet" contact breaker, invented by M. Levy in 1899. The method of working is shown in Figs. 629 and 630.\* A horizontal metal disc *g* (Fig. 630) is mounted on a vertical spindle, which is driven in some simple manner by an electric motor, as shown in Fig. 629.

\* Illustrations lent by Mr. A. W. Isenthal.

Fixed to the rim of the disc are a series of vertical teeth *f*, which can be cut to any desired shape, but are usually long triangles with the apex downwards. Lower down the vertical shaft drives a small displacement pump which is immersed in the mercury lying in the bottom of the chamber, the mercury not being high enough to reach the prongs of the revolving disc. When the shaft revolves the pump drives some of the mercury into a vertical tube and discharges it from a horizontal nozzle *n*, which can be adjusted with its orifice at any desired level opposite the revolving teeth. The result is that the teeth cut through the fine jet of mercury and contact is made when the mercury impinges on a tooth, and broken when it passes through the openings between the teeth. The ends of the primary circuit are electrically connected to the teeth and the mercury respectively, and there-

fore by varying (i.) the speed at which the disc is driven, (ii.) the shape and distance apart of the teeth, or (iii.) the position of the nozzle which discharges the mercury jet, any desired rapidity and form of break may be obtained. For instance, the frequency of the interruptions can be

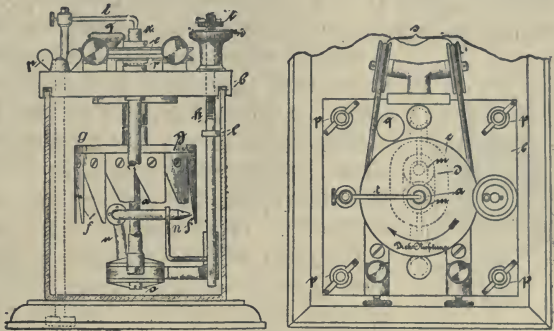

Fig. 630.—Mercury Jet Interrupter.

pushed to many thousands per second (72,000 have been claimed), and, since the fraction of the full period during which contact is made can be altered, the mean current strength is perfectly under control from zero to the maximum when the interruptions cease. As soon as the speed of the shaft drops below a certain number of revolutions per minute or stops, the mercury jet ceases and the primary circuit remains permanently broken until the minimum speed required to pump the mercury up to the nozzle is again attained. In the most recent forms it is possible to alter the position of the jet whilst the spindle is running, which enables the operator to control the secondary circuit discharge in a simple and easy manner:

**Thermal or Electrolytic Interrupters.**—Early in 1899 a new method of producing an intermittent current in a continuous current circuit was discovered by A. Wehnelt. It had long been known that if one of the electrodes of a voltmeter be made very small this electrode becomes luminous, and that the effect shows signs of intermittance. To investigate this intermittance Wehnelt arranged a voltmeter in a beaker *a* (Fig. 631)



of dilute sulphuric acid, with a lead plate *b* for one electrode, and with a fine platinum wire *c* for the other electrode. Current was conducted to the wire *c* by mercury contained in the small tube *d*, through the closed end of which the platinum wire was sealed. On passing a current of 6 amperes at 20 volts through the voltameter and the primary of an induction coil, he found that the voltameter gave about 1,000 interruptions per second with remarkable regularity, and that with the primary current so interrupted he obtained sparks 16 inches long between the secondary terminals. The platinum wire was in all cases the anode, and no condenser was required.

This important discovery immediately attracted a great deal of attention, and numerous experiments were made with very little delay. It soon became apparent that the working of such a contact breaker was not so simple as was at first supposed. For instance, it was found that unless there was inductance in the circuit the interrupter would not work. In

Wehnelt's experiments the inductance of his primary coil appears to have been sufficient, but other experimenters were not so fortunate. The fact that a condenser is unnecessary can be explained by the known condenser effect which a voltameter shows when subjected to varying P. D.'s, the interrupter thus acting both as an interrupter and a condenser. In such a case the periodicity of the interruptions might well be expected to depend on the inductance and capacity of the circuit, but it was also found to depend on the E. M. F. in the circuit. Further, if an alternate current were used, the current very often only passed in one direction.

D'Arsonval explained the action in this way. By the passage of the heavy current used the platinum point is made white-hot and a layer of non-conducting vapour is formed round it, interrupting the current. The vapour then condenses, the circuit is again closed, the current re-starts, and the process is repeated! This theory is supported by the fact that if the liquid be heated to 90° C. the interrupter does not act, the vapour being no longer condensed; but if it be correct there is no electrolytic action. It may, however, be pointed out that a gaseous non-conducting envelope can be formed by electrolysis, and the current thereby interrupted; the sudden interruption causes a rapid inductive rise of P. D. at the break, and this high P. D. may cause a spark discharge, which dissipates the electrolytic gas and again establishes the circuit.

At first it was thought that the interrupter would only work when the fine wire is the anode, but by careful adjustment interruptions of about half the frequency can be obtained when it is the kathode. Further, Caldwell discovered in 1899 that the interruptions can be transferred from the electrodes to a small aperture in an insulating partition separ-

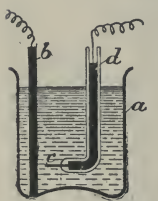

Fig. 631.—Wehnelt's Interrupter. (Early form.)

ating the voltmeter into two sections each containing an electrode. Two forms of his interrupter are shown in Figs. 632 and 633 respectively. In Fig. 632 the vertical partition separating the vessel into two parts contains a hole in which is placed a plug with a small orifice, whilst in Fig. 633 the communication between the two parts of the vessel is by means of a small hole

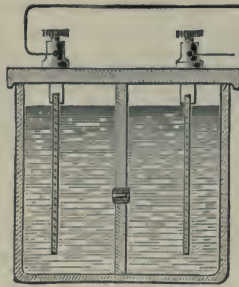

Fig. 632.

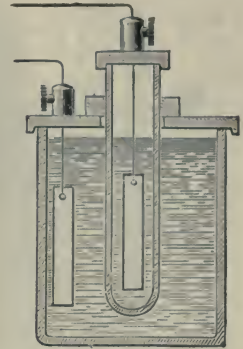

Fig. 633.

Caldwell's Modification of Wehnelt's Interrupter.

in the glass test-tube immersed in the outer vessel. It may be pointed out that in this form of interrupter it is probable that the action is purely thermal. The frequency of the interruptions was pushed as far as 400

or 500 per second. A similar interrupter devised by Mr. Campbell Swinton, and having the size of the aperture adjustable, is shown in Fig. 634. The electrodes *c* and *d* are lead sheets placed *d* in the outer vessel *A A* and *c* in the glass tube or cylinder *B*, in the bottom of which is a circular aperture *E*, 3 or 4 millimetres in diameter. A conical glass rod or stopper *F* passes through the aperture, and can be moved up and down by the screw *H* to which it is fixed. The effective size of the opening at *E* depends on the position of *F*. It was found that, with a given inductance and voltage, the current and the periodicity could be varied within wide limits. An overflow *J* is provided in the inner tube, as it is found that the liquid rises in this tube when the interrupter is working.

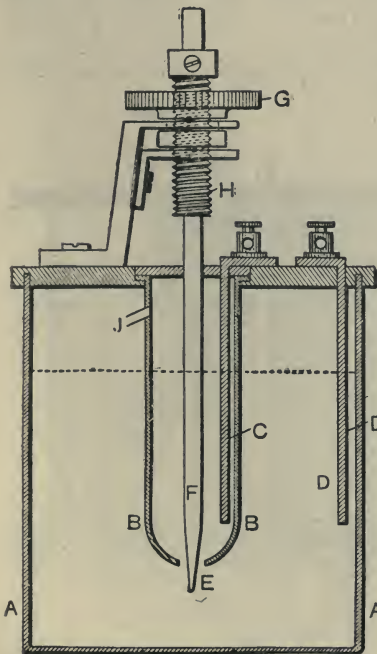

Fig. 634.—Swinton's Modification of Wehnelt's Interrupter.

The frequency and current can also be controlled in interrupters of the original form by altering the length of the platinum wire, and the interrupters

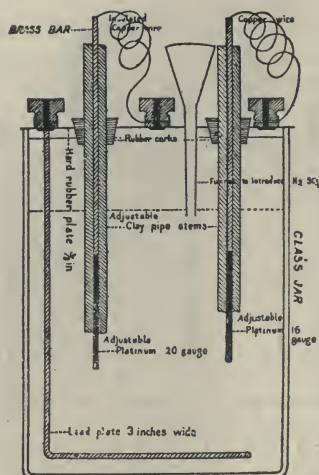

Fig. 635.—Price's Modification of Wehnelt's Interrupter.

placed near the operator. In Fig. 635 the other electrode is a sheet of lead bent at right angles.

In more recent forms of Wehnelt's interrupter the electrodes are placed in a large vessel containing plenty of sulphuric acid. This is to prevent the temperature from rising rapidly, as it would if only a small quantity of acid were present. It has been mentioned that when the temperature of the liquid approaches  $100^{\circ}$  C. the interrupter will not work. Two such forms with adjustable platinum electrodes, as constructed by Messrs. Isenthal & Co., are shown in Figs. 636 and 637. The former has a single platinum point, and the latter has three, which can be adjusted differently and used as explained above; near the top of each tube is a small discharge pipe to act as an overflow, for reasons already

of this type generally have some method of adjusting this length. Such an interrupter, described in 1900 by W. A. Price in the *New York Electrical Review*, is shown in section in Fig. 635, which is almost self-explanatory. The essential part is that a short piece of platinum wire attached to a longer piece of brass wire passes down through a pipe-clay stem, and the length exposed in the liquid can be varied by drawing the wire up or down. Two wires are provided, so that by switching over from one to another the character of the discharge in the secondary circuit can be quickly changed. This is convenient, because the interrupter makes so much noise that with nervous patients it is found advisable to place it in a distant room. The switches in the two circuits are, of course,

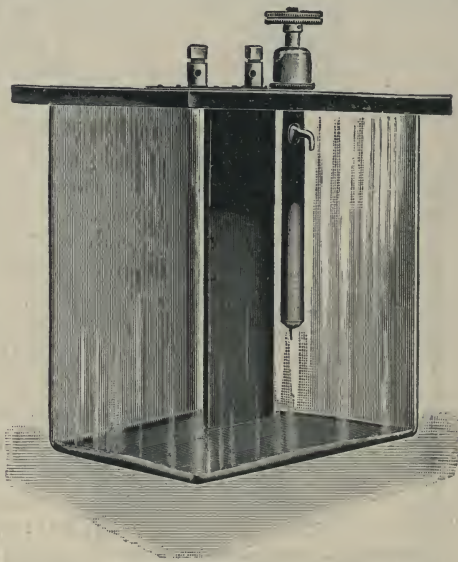

Fig 636.—Wehnelt Interrupter with adjustable electrode.



given. In other forms special devices, such as water cooling, etc., are used to keep the temperature from rising.

**Tesla High-Frequency Interrupters.**—By inserting in the discharge circuit of a condenser placed in the secondary circuit of an induction coil the primary of another coil, currents of very high frequency (probably of a periodicity of many millions per second) can be obtained. The arrangement is shown in Fig. 638, in which A is an ordinary induction coil, in the primary circuit of which there is one of the interrupters already described. The wires *s s* from the secondary terminals

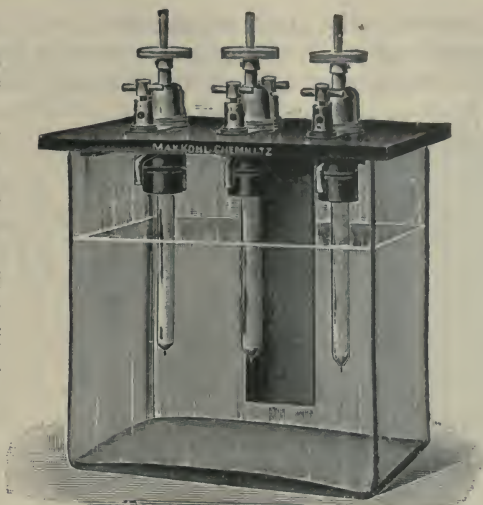

Fig. 637.—Wehnelt Interrupter with three adjustable electrodes.

are led to the two sides of a spark gap *g*, to which plates *c c* are attached to give capacity. The two sides of the gap are also connected to the primary *p* of an ironless Tesla transformer (see Fig. 400) immersed in an oil vessel. The oscillations in the gap *g* are very rapid, as also are the oscillations in *p*, and therefore from the secondary terminals of this transformer very high frequency currents can be obtained.

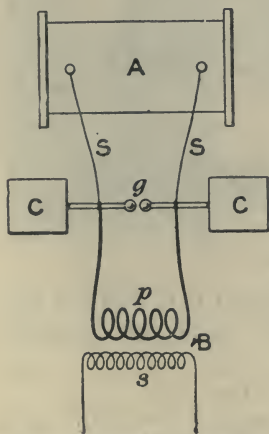

Fig. 638.—Diagram of Tesla Apparatus.

A more recent arrangement, the result of the researches of D'Arsonval, Oudin, and others, is shown diagrammatically in Fig. 639, whilst Fig. 640 gives the actual apparatus: The induction coil A (not shown in Fig. 640), worked in the ordinary way, has its secondary terminals connected to the spark gap *g* contained in the box *c*. The knobs of the spark gap are connected to the inner coatings of the Leyden jars *L L* through their knobs *c c*. The outer insulated coatings of the jars are connected through the spiral *s* of stiff copper wire, from one point of which a movable contact *κ* makes connection to the end of a second open spiral *R* of bare copper wire wound on a wooden frame. This spiral is called by its inventor, Oudin, a

resonator, and it is sometimes made so large that a full-grown man can be placed inside. Its distant end is shown in Fig. 639 connected to a discharging arrangement D, but it is often joined directly to other apparatus. The

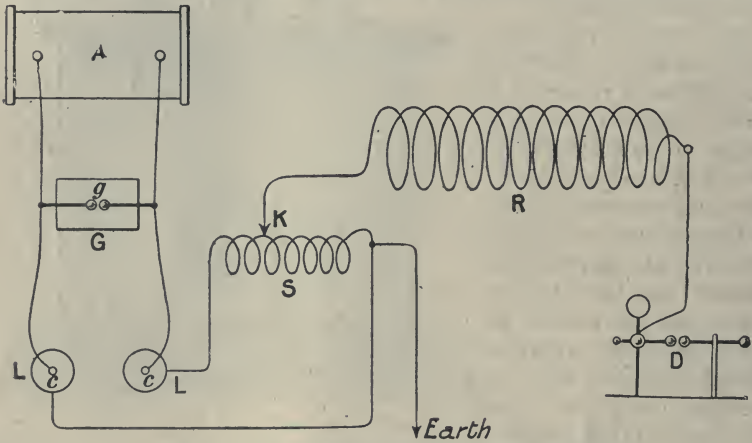

Fig. 639.—Diagram of recent arrangement of Tesla Apparatus.

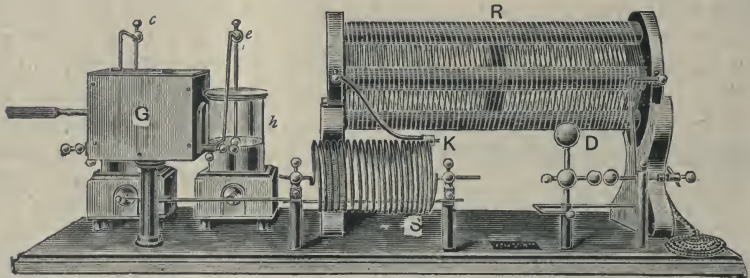

Fig. 640.—Recent Tesla Apparatus.

action at D can be controlled by moving the contact K to different positions on the spirals, and it is very much increased by connecting one end of S to earth as shown in Fig. 639.

### III.—THE ELECTRIC SPARK IN AIR:

It has been explained (page 82) that the passage of the electric spark between two conductors at different potentials will take place when the electrostatic, or more briefly the electric strain in the dielectric between them, becomes so great that the dielectric is ruptured: The P.D. required to produce the spark under precisely similar conditions through different dielectrics varies and depends upon what is called their *electric strength*. The distance across which the spark will strike depends, however, not only

on the nature of the dielectric but also upon the shape and condition of the electrodes, and upon the P.D. produced between them. The P.D. per centimetre of distance apart is sometimes referred to as the *electromotive intensity*, and it might be expected that in a given dielectric the spark would always pass when the electromotive intensity reached a definite value, or, in other words, that the

length of the spark would be proportional to the P.D. Reference, however, to the tables and curves given on pages 129 to 131 *ante* shows that is certainly not the case. For long sparks the electromotive intensity is less than for short ones. As previously pointed out, this is probably due to the lines of force being crowded together near the electrodes, where, therefore, the electromotive intensity becomes greater than the mean value for the whole distance. The dielectric then gives way in the neighbourhood of the electrodes, and the disruption, having once started, spreads rapidly.

The form of the discharge for a short air-gap is shown in Fig. 641, where the spark is being taken between a small + sphere and a larger - sphere forming the electrodes of an influence machine. The sparks,



Fig. 641.—The Straight Spark.

which rapidly follow one another, form a more or less thick band of light. Incidentally it may be mentioned that Faraday\* long ago found that for such electrodes far longer sparks are obtained when the small ball is + than when it is -. In one experiment the reduction was from 10 to 12 inches in the first case to 1 or 1½ inches in the second. This is an indication that, as already mentioned (*see* page 132), the so-called positive and negative charges have physical differences which are not explained by regarding them as the opposite ends of the same strain as represented by the lines of force. Further differences will appear as we proceed.

\* *Experimental Researches*, vol. i. (1838), series xiii. 1482.



Fig. 642.—The Forked Spark.



If the distance the spark has to pass becomes very great, uniform luminosity and motion in a straight line cease. Powerful sparks over-leaping a great distance have the appearance shown in Fig 642. Or when the quantity of electricity discharged is very great the spark may split up into several distinct lines of light sprinkled with bright beads, as shown in Fig. 643, which represents discharges  $13\frac{1}{2}$  inches long obtained from the 12-plate Wimshurst machine of Fig. 87. The beads are probably places at which the zigzag path of the spark is seen, more or less, "end-on." The ramifications and zigzag path may be explained by assuming that the discharge always takes place along the line of least resistance, and that, owing to disturbances set up by the passage of the spark itself, inequalities in density, temperature, etc., are set up in the air sufficient to account for the phenomena. When a spark passing between metals is analysed spectroscopically, it is found that the colour of the spark

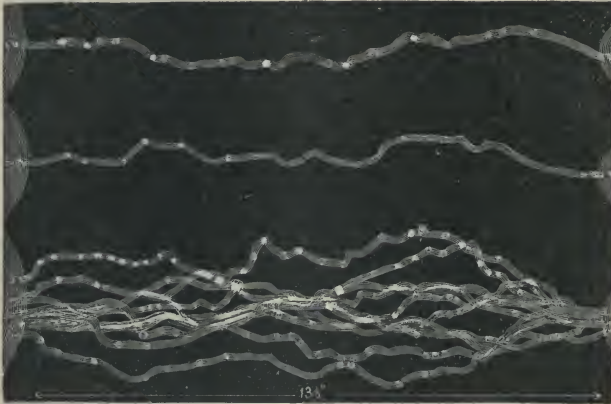

Fig. 643.—Discharge from 12-plate Wimshurst Machine.

depends on the metals and the gas through which it passes. The electric spark is probably a consequence of the heating effect of the discharge, which renders particles of gas and metal incandescent. That particles of metal are really torn

off during discharge can easily be proved by examining the metal points between which the discharge takes place; metal particles are carried away from one and deposited on the other. If, for instance, two metals be taken, copper and silver, and the spark passes from the silver to the copper, a deposit of silver is found on the copper. A long spark can also be broken up into a series of short sparks by placing successive intervals in the path, and provided that the sum of the intervals be not greater than the gap the spark can spring across. A well-known experiment of this kind is the spangled tube (Fig. 644), in which a spiral of bits of tin-foil at short distances apart is placed between the electrodes.

**Electric Waves.**—Throughout this book it has been continually impressed upon the reader that electrical phenomena are not confined to the

substance or surfaces of conductors, but that the whole surrounding medium plays a part in the actions and reactions which are taking place. Thus, if the so-called electric current is passing along a conductor, the medium outside the conductor becomes magnetically strained, and the magnitude of the strain depends upon the magnitude of the current, and varies as the latter varies. Again, if an insulated conductor is raised to a high potential relatively to surrounding conductors, the dielectric surrounding it is electrostatically strained, and the magnitude of the strain at any point depends, *cæteris paribus*, on the value of the potential, and varies with it. Moreover, in the case of the current-carrying conductor there is an electric strain as well as a magnetic strain, because it is, from point to point, at a potential different from that of neighbouring conductors. In this case the lines of force by which the two fields can be represented are mutually at right angles throughout the medium.

Now, seeing that these states of strain have to be set up in the first instance and afterwards varied with every variation of the producing cause, the question naturally arises as to whether any appreciable interval of time elapses between the commencement of the action in or at the conductor and the appearance of the strain at any distant point. In other words:—Is the strain set up simultaneously throughout the whole mass of the medium, or is the disturbance which causes it propagated with a definite or a variable velocity from point to point, reaching the distant points later than the nearer ones? The answer is that the electric disturbances setting up the strain *are* propagated through the medium with perfectly definite velocities, and that if the disturbances succeed one another rapidly they travel through the medium as a series of waves. Moreover, Poynting showed long ago that, in the case of a steady current flowing in a simple circuit, consisting of a battery and a conducting wire, the energy which is dissipated as heat in the wire travels from the battery to the various parts of the wire through the medium, and not along the wire. This is an extremely important point.

**The Electro-magnetic Theory of Light.**—It was during the third quarter of the last century that Clerk Maxwell first promulgated his celebrated theory that light is an electro-magnetic phenomenon. The chief basis of the theory was the experimental fact that the velocity with which an electro-magnetic disturbance is propagated in a vacuum is, within the limits of experimental error, the same as the velocity of light, namely, about 185,000 miles per second: The conclusion is almost irresistible that the two



Fig. 644.—The Spangled Tube.

phenomena, both forms of wave motion, which are propagated with this unique velocity, are not only similar, but identical, and can only differ in the ways in which one wave differs from another of the same kind—that is, in *frequency and wave-length*. For many years, however, the measurement of the electric wave velocity was made by indirect experiments, the actual waves not being experimented with.

The difficulties in the way of direct experiment appear insuperable at first sight. Not only is the velocity very high, but in many ordinary cases the size of the waves is enormous. Thus, in the case of the oscillatory discharge of a condenser, which is one of the methods of starting the necessary disturbances, the period,  $\tau$ , of an oscillation calculated by the formula given on page 647 may in many cases be longer than the  $\frac{1}{1,000}$ th of a second. But even if the period be so short that the disturbances are at the rate of 1,000 per second, then, the velocity of the waves being 185,000 miles per second, it follows that the wave length, *i.e.* the distance from crest to crest, must be 185 miles. Man has no special sense by which he can detect the presence of such enormous waves in the medium surrounding him. His sense of sight, which, on this theory, is an electro-magnetic or electric sense, can only respond to extremely small waves at excessively high frequencies, and, moreover, the range of response is a very limited one. To affect the human eye the disturbances must follow one another somewhere between 390 to 760 billions of times per second, the corresponding wave lengths being from  $\frac{1}{33,000}$ th to  $\frac{1}{84,000}$ th of an inch. It is only within these limits, comprised within less than a single octave of the possible vibrations, that the eye can see; to all other disturbances and to the infinite number of waves existing outside these limits it is absolutely blind. What is wanted, then, is an artificial electric eye, which will enable us to detect, examine, measure, and experiment upon these other waves, if they exist. Such an eye was first devised by Hertz in the year 1887.

**Hertz's Experiments.**—The success of Hertz's experiments was due to the use of special radiators, by which electric waves of a definite period could be generated in the medium, and also to the employment of resonators, as they were called, which acted as detectors by which the presence of the waves could be detected and their form analysed at a distance from the radiators.

The phenomenon of resonance is best known in acoustics, from which science, in fact, it takes its name. Thus, if two stretched wires are tuned to give out exactly the same note, and one of them be set vibrating in the neighbourhood of the other, this second string will also start vibrating without being touched. Or, again, the air in an organ pipe can be set vibrating by bringing a vibrating tuning fork, of the same pitch as the pipe, near the mouth of the latter: Many other instances will probably occur to the reader:



Now, it has been shown (page 647) that when a condenser is discharged through a circuit of negligible resistance the discharge is oscillatory, and has a definite period depending upon the capacity of the condenser and the inductance of the circuit. For instance, let the terminals of the induction coil *C* (Fig. 645) be connected to a condenser of the form shown, and consisting of two metal plates, *P*, *P'*, each 40 centimetres square, set up in the same plane 60 centimetres apart and joined by wires, except for a small gap at *G*, the wires at the gap terminating in brightly polished metal balls, with their surfaces 3 mm. apart. By the action of the coil the P. D. of the balls will rise until the dielectric in the gap breaks down under the strain and discharge takes place between the plates *P* *P'* through the wires and across the gap. The periodic time of the discharge, calculated from the above dimensions and the formula already given, is found to be  $3.3 \times 10^{-8}$  second. There are, therefore, about thirty oscillations in the millionth of a second, if so many can be obtained with a single discharge; but this is doubtful, as they are very rapidly damped, partly by heat generated in the wire and

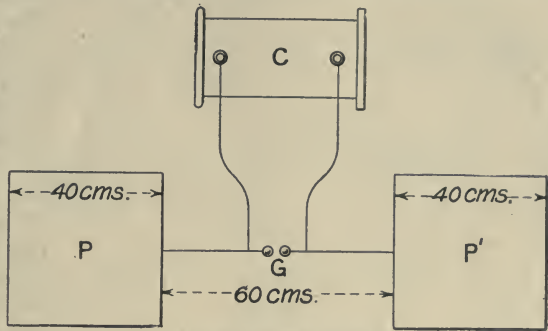

Fig. 645.—Hertz's Oscillator.

partly by radiation. For, these rapid discharge oscillations in the spark gap set up disturbances in the ether which give rise to a series of waves which carry off some of the energy used originally to charge the condenser. If these waves from the "oscillator," as it is called, fall properly upon another circuit *R R* (Fig. 646), in which the period of discharge would be exactly the same, they will set up, by resonance, electric surgings, and if there be a spark gap, *g*, in this circuit, these surgings will give rise to a spark or sparks in this gap. This second circuit, or "resonator," was constructed by Hertz, for the oscillator above described, of 210 cms. of No. 17 wire bent into the form of a nearly closed circle, the ends carrying two little brightly polished brass balls separated by a very narrow gap. The evidence of the surgings was the appearance of sparks more or less minute in this gap. The metal circle was mounted on a non-conducting wooden frame for convenience in carrying and to allow the length of the gap to be adjusted.

With apparatus of this simple character Hertz was able to prove experimentally that electric waves were generated by his oscillator and were propagated through the surrounding medium with the velocity of light, thus

verifying Maxwell's prediction. For this purpose it was necessary to prove the existence of the various phenomena usually associated with wave motion, such as reflexion, refraction, interference, and polarisation.

**Reflexion and Interference.**—Maxwell's theory shows that metallic surfaces should be impervious to the waves and should act as reflectors: If, therefore, electric waves fall normally upon a plane sheet of metal, they should be reflected back along the incident path and produce the well-known phenomena of *stationary waves*. Thus, in Fig. 647 let the oscillator be set up some distance to the left on the axial line, and let M be a reflecting mirror consisting of a sheet of metal set up parallel to



Fig. 646.—Hertz's Resonator (one-tenth full size).

to the line of oscillation at a considerable distance. The incident waves will then be plane waves, with their vibrating parts moving parallel to the surface of M. At a given instant the incident waves may be represented by the curves *a*, and are travelling from left to right. In the act of reflexion the phase is reversed at M, and at the instant just referred to the reflected waves taken alone would be represented by the curve *b*, and would be travelling from right to left as shown

by the arrows. To find the effect of both sets of waves at the given instant these two curves are to be added together, and the result is the straight line *c*, which means that momentarily all the vibrating parts are at rest.

Fig. 648 shows the state of affairs  $\frac{1}{4}$ -period later. The waves *a* have moved a quarter-wave length to the right, and the waves *b* a similar distance to the left. The resultant now is the wave *c*, of double the amplitude of *a* or *b*. But these waves do not travel either to the right or the left; they remain stationary. This will be clearly seen on inspecting Figs. 649 and 650, which show the position of affairs a  $\frac{1}{2}$ - and a  $\frac{3}{4}$ -period respectively later than Fig. 647. The final result is that the points N are positions of no motion or minimum motion, where the resonator (Fig. 646) will give feeble or no sparks, and the points L are positions of maximum disturbance, where the resonator will give bright sparks. For simplicity the waves have been

drawn of equal amplitude, but as some energy is lost at M the reflected wave causes less disturbance than the incident wave, and therefore the

points N are not positions of rest, but only positions of minimum disturbance. The positions N are known as *nodes*, and the positions L as *loops*. Now it is obvious that when the positions of the nodes and loops have been determined the wave length can be measured, for successive nodes or successive loops are half-wave lengths apart. In the case of the oscillator referred to above the distance apart of successive nodes was found to be about 5 metres; the waves were therefore 10 metres (1,000 cms.) long. The calculated periodicity was 30 millions of periods per second, and therefore the velocity of propagation, which is equal to the product of these two quantities, was about  $(30 \times 10^6 \times 1,000) 3 \times 10^{10}$  cms. per second, which is the velocity of light.

By using large cylindrical mirrors, with a parabolic section, as shown in Fig. 651, the waves can be brought to a focus as in familiar experiments with waves of light. The oscillator

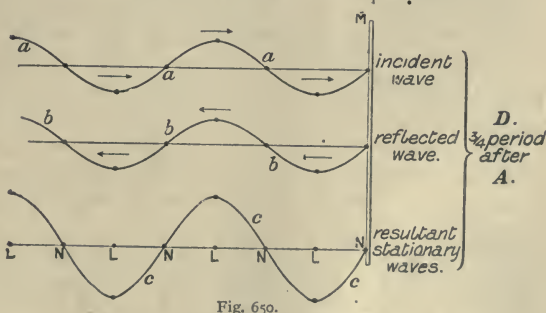
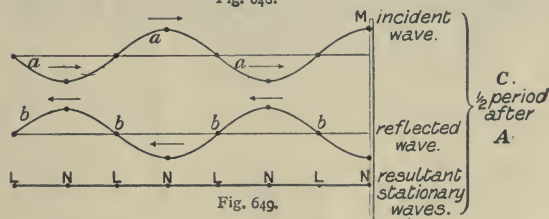
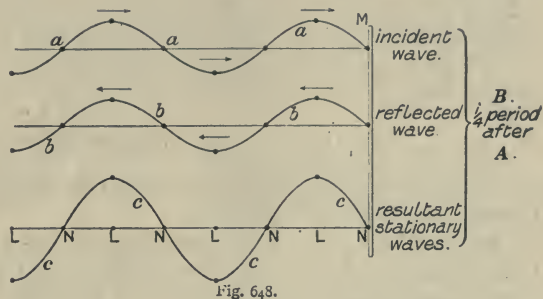
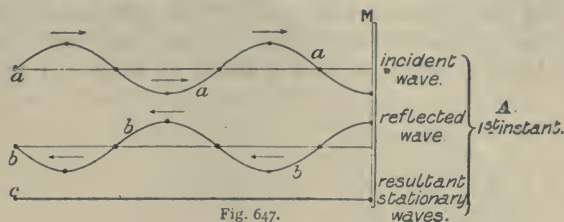

Interference of Direct and Reflected Waves.





brick, wood, etc., are transparent to the electric waves, and by analogy we should expect to obtain evidences of refraction, due attention being paid to the enormous difference in the length of the waves. With waves of light the bending can be most conveniently shown by using a small prism of glass or other transparent substance. To electric waves such as we have been considering pitch is transparent, and a large prism  $P$  (Fig. 652) of this material may be placed in the path of the waves proceeding from the oscillator  $O$  after reflexion at the cylindric parabolic mirror  $M_1$ . The second mirror  $M_2$ , with the resonator at its focus, is to be used to search for the waves after passing through  $P$ , the direct waves being cut off by a metal screen  $S$  of sufficient size. As  $M_2$  is moved over the arc  $AB$ , no evidence of the existence of the waves can be obtained until it is brought to some such position as is indicated in the figure, showing very marked refraction of the waves on passing through  $P$ . From the amount of the refraction and the angle of the prism the speed of the waves in pitch can be calculated by well-known laws; it is obvious that this speed could not easily be measured directly.

**Polarisation.**—The most conclusive evidence of the wave nature of the phenomena is furnished by experiments on polarisation, a subject to which we have more than once (*see* pages 66 and 317) referred in connection with waves of light. The oscillator we have described generates polarised electric waves, in which the direction of electric displacement is parallel to the line joining the plates. As an analyser to examine this polarised condition, it is only necessary to use a simple grating  $ABCD$  (Fig. 653) of parallel copper wires in a wooden frame. Through such a grating oscillations in the direction of the dotted line  $HH$  can pass, but to oscillations in the direction  $v v$  the grating will behave as an opaque body. This is because the oscillations in the latter direction can induce oscillations in the vertical wires, which by their effect, if the wires are close enough, will completely screen the space behind the grating. Placing, then, a screen of this kind between the mirrors in Fig. 651, we can either allow all the oscillations to pass by holding the screen with the line  $HH$  parallel to their direction, or we can completely stop the waves by so setting the screen that the line  $v v$  is parallel to the electric disturbances. The experiment when tried is found to be perfectly successful.

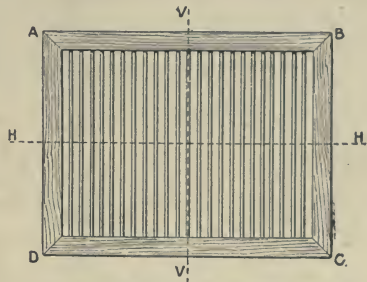

Fig. 653.—Polarising or Analysing Grating.

With these experiments before us proving the existence of reflexion, refraction, interference, and polarisation, there can be no doubt but that we are dealing with *waves*, for it is only by assuming wave motion that a

satisfactory explanation of the somewhat intricate series of phenomena can be offered.

In the foregoing, for simplicity, we have referred only to the electric waves set up in the ether by the electric surgings in the oscillator, but a moment's consideration will show that these surgings must give rise to magnetic effects. These effects, according to the elementary laws, fully dealt with in the preceding chapters, will give rise to magnetic disturbances at right angles to the electric ones. Hertz proved experimentally that the magnetic disturbances are propagated with the same velocity as the electric disturbances, and that, in fact, the complete wave is electro-magnetic, and that the wave-front at every point consists of electric and magnetic disturbances at right angles to one another and to the direction of propagation.

This is in strict accordance with the requirements of Clerk Maxwell's electro-magnetic theory of light.

Hertz's work produced great excitement in the scientific world, and numerous observers repeated and varied his experiments. Space will only allow us to

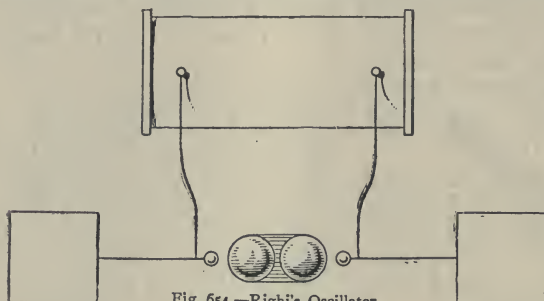

Fig. 654.—Righi's Oscillator.

refer to a few of these developments, which included improvements in both the generators and the detectors of the radiations, as well as investigations into many details.

Amongst the improvements in the "oscillators" or generators of the radiations, one devised by Righi deserves special mention. Instead of a single pair of spheres at the spark gap, he used three, or better still four, as in Fig. 654, the two central ones being much larger than the ones connected to the wires. These larger spheres were very close together, and their opposed surfaces were immersed in an insulating oil which requires a greater electric strain to rupture it, and therefore gives a much more vigorous spark when broken down.

Many additional detectors of the existence of the waves, or receivers as they may be called, were also discovered. Amongst these may be named vacuum tubes, galvanometers, electroscopes, impulsion cells, and coherers, the last named being perhaps the most important, and therefore requiring further explanation.

**Coherers.**—Branly observed that if a few scattered metallic filings are made part of an electric circuit, their resistance in the ordinary state may be very high, but that this resistance is considerably reduced when



electric waves such as we have been discussing fall upon them. Further, it was noted that the high resistance state could be restored by mechanical means, such as by tapping the tube or other support of the filings. To an arrangement of this kind Dr. (now Sir Oliver) Lodge gave the name of a *coherer*, since the reduced resistance seemed to be due to the metallic particles cohering under the action of the electric surgings induced by the waves. The diminution of the resistance can easily be observed by placing in the coherer circuit a galvanometer or other device which will respond to the increased current in the circuit. The simplest coherer circuit would, as in Fig. 655,

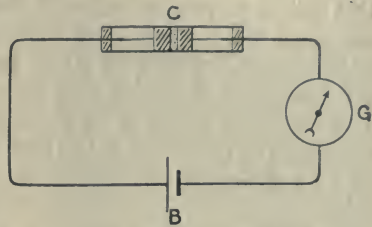

Fig. 655.—Simple Coherer Circuit.

consist of the coherer *c*, a battery *B*, and a galvanometer *G*. For many purposes, however, it would be better to replace the galvanometer by a relay *R* (see page 401) in the local circuit, of which (Fig. 656), besides the battery *L* and the relay contact *c*, there is an electro-magnet *M*<sub>1</sub>, and a telegraphic receiving instrument, such as a Morse writer *M*<sub>2</sub>. The function of the former is to act as a *decoherer* by causing its armature, *b*, when attracted, to strike the board on which the coherer is mounted, and thus restore the metal filings to the sensitive state of high resistance.

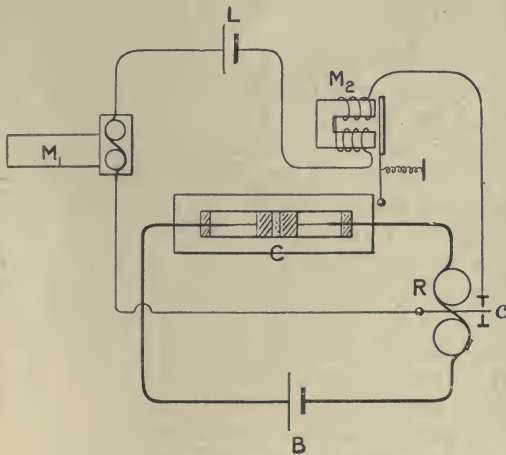

Fig. 656.—Receiving Circuits with Decoherer.

*Anti-Coherers*.—Neuenschwender, Schofer, and others have constructed receiving apparatus for electric waves in which the effect produced is the opposite of that produced by the waves on a coherer, that is, the impact of the waves causes the resistance to rise instead of fall. These anti-coherers, as they are called, have the additional valuable property that on the cessation of the waves the low resistance state is resumed without requiring the intervention of anything corresponding to the decoherer in the other case. The arrangement is very simple, consisting only of a linear flaw produced by lightly drawing a fine line with a diamond or razor edge in a

deposit of silver on glass. Such a flaw, about 3 cms. long, will have a resistance ordinarily of about 40 ohms, which will be increased about threefold when electric waves fall upon it, and will promptly resume its original value when the waves cease. Neugeschwender, who first observed this action, prefers to bridge his flaw with a film of moisture, with which he observed the resistance to fluctuate between 50 and 90,000 ohms. An anti-coherer can also be made by forming a connecting bridge of silver 0.1 mm. wide in a very wide gap, the whole being coated with collodion. The restoring action is so prompt that the signals can be received in a telephone in circuit with the anti-coherer.

The theory of the action, which we have not space to discuss, is the subject of controversy. On one side it is alleged that electrolysis plays an important part, on the other that the action is purely mechanical. In either case the impact of the waves disturbs the arrangement of fine particles of silver lying in the gap, and so increases the resistance, but the promptness of the restoration is not so easily explained.

**Transparency of Materials.**—The fact which appealed most to the man in the street when Hertz's discoveries were announced was the ease with which the electro-magnetic waves passed through substances which are ordinarily considered opaque, and are opaque, to waves of light. Thus, if the oscillator is shut up in a room of a building, the waves can be detected and picked up in the grounds outside, or in another room of the building, although to reach the position of the detector they must pass through solid walls of masonry or other building material. These phenomena are, however, quite in accordance with well-known and familiar properties of waves of light which can pass through glass and other bodies quite as solid as stone or brick. Moreover, it has long been known that glass is opaque to many waves with which we have been long familiar, and that it is only transparent to waves of a certain length or periodicity, amongst which happen to be the waves which affect our sense of sight. Stone, on the other hand, lets through certain waves of long wave length, but is opaque to the short waves which constitute light. The materials, therefore, act in the same way. Each is both transparent and opaque, but one is opaque to waves to which the other is transparent, and *vice versa*, but not completely, as there are many waves which pass through both.

**Wireless or Radio-Telegraphy.**—Coherers as detectors of electric waves are much more sensitive than Hertz's resonators, and with their invention and with the more energetic oscillators of Righi, Tesla, and others, it soon became possible to pick up the electric waves at much greater distances from the oscillator. To obtain definite signals the oscillator was connected to the secondary terminals of an induction coil, in the primary circuit of which a Morse key was inserted, as well as the automatic contact breaker. Thus waves of long and short duration were sent out, the Morse code (*see* page 405)

being used to form letters and words. These waves being received by a detector arranged as in Fig. 656, a working current passed through the relay R as long as waves were falling on the coherer C, but when a break came in the stream of waves the decoherer M, restored the coherer to its original condition of high resistance, the current then passing being insufficient to move the tongue of the relay. Thus the receiving instrument M, only registered signals when waves were falling on C, and therefore faithfully followed the movements of the key in the transmitting apparatus.

By careful improvement of the details of the transmitting and receiving apparatus, and by minute study of the conditions necessary for success, Marconi, Slaby, and others have rapidly increased the distance at which the waves can be detected. At the end of 1901 Marconi was so far successful that he detected in Newfoundland waves generated in Cornwall, the distance being over 2,000 miles. Into the technical details we cannot enter here, but we hope to return to the subject later in the technological section.

One word in conclusion. The term "wireless" only applies to the absence of the conducting wire between the transmitting and receiving stations in ordinary systems of telegraphy. At both the stations numerous wires are necessarily used, and therefore the term "radio-telegraphy" is now officially employed as more suitable.

#### IV.—THE DISCHARGE IN PARTIAL AND HIGH VACUA.

Dry air at ordinary or higher pressure allows the discharge to pass when the voltage is sufficiently high, and also under the special circumstances already detailed; on the other hand, a perfect vacuum is almost a perfect insulator, and quite a different set of phenomena are experienced. Between these extremes there are degrees of rarefaction which allow a flow of electricity, and present many remarkable and beautiful effects. Glass tubes partially exhausted are used for this purpose, and these so-called "vacuum tubes" are sometimes named, after the most celebrated makers or investigators, Geissler's or Gassiot's tubes. They are usually thin glass



Fig. 657.—The Electric Egg.



tubes with bulbs blown at the end, and more or less twisted into different shapes, and have at two different points platinum wires fused into them. By means of these wires or electrodes, the currents from an influence machine, or more frequently the sparks from an induction coil, are conducted through

these tubes, so as to make the more or less rarefied gases glow:

#### Discharges in Moderate Vacua.

—The so-called "electric egg," which preceded the invention of Geissler's tubes, is shown in Fig. 657. It consists of a glass globe shaped as represented in the figure, the brass fittings of the upper end having an air-tight stuffing-box, or perforated cork, through which the electrode can be moved. The brass fittings at the lower end carried the second electrode, which, as a rule, was fixed. The lower portion of the foot was accurately ground, so as to fit tightly on the plate of an air-pump. By means of a stop-cock the pressure could be regulated, or the egg closed when the desired degree of exhaustion had been attained.

Figs. 658 and 659 represent two of Geissler's tubes. The one narrow at the middle is especially useful for spectrum analysis, as the spectrum from the light in the narrow portion is much more distinct. These tubes are usually sold closed at both ends, filled with gases or vapours at pressures from 0.08 to 0.25 inch. When



Fig. 658

Geissler's Tubes.

Fig. 659.

the discharges are passed through bulbs or tubes like Figs. 658 and 659, filled with air under the ordinary pressure, a continued stream of sparks passes, provided the induction coil be sufficiently powerful. If now the air in the tube be rarefied, the spark decreases, until at last it disappears altogether, giving place to a kind of brush discharge at the positive pole and a glow or aureole surrounding the negative pole, and well shown in Fig. 658. Immediately surrounding this glow is a dark space, outside which luminosity again commences, but much more

faintly. If the tube contains rarefied nitrogen the negative brush light appears brick-red or rose-coloured, the glow light blue or violet. In hydrogen the glow is blue, but the light in the narrow part of the tube is crimson. The intensity of the light is different at different places; it is much the brightest in the narrow portion of the tube.

**The Mercury Arc.**—As an important application of the electric discharge under reduced pressure, it will be convenient here to consider the “mercury arc,” to which some reference has already been made (*see* page 270).

In a Geissler tube at moderate exhaustions, the glow of the discharge for all practical purposes appears to fill the whole tube if the pressure voltage and current be properly adjusted in connection with the length of the tube and the material of the electrodes. Reference has been made above to the colour of the glow as influenced by the character of the residual gas, but when the electrodes are volatilisable the light from the glowing particles detached from them quite overpowers the feeble glow of the permanent gases and dominates the character of the emitted light. On account of its fluidity at ordinary temperatures the metal mercury is now widely employed for the electrodes of a vacuum tube which is to be used for artificial illumination. One advantage of a liquid electrode over a solid one is that the latter would be gradually disintegrated and would have to be renewed, whereas a liquid electrode, as particles are torn off, continually presents, by its mobility, fresh and perfect surfaces to the space in which the discharge is being exhibited.

Vacuum lamps in which the vapour of mercury was used to carry the current were described as far back as 1892 by Arons, but not much notice was taken of them. Some years later more than one physicist modified or re-invented the Arons lamp as a means of obtaining practically monochromatic light for spectroscopic or other work. As a method of general illumination it was developed by Mr. Cooper Hewitt about 1901, and since that date a fair amount of research and other work has been done in the subject.

For practical purposes it is necessary that the vacuum tubes which are to be used as lamps should be capable of being run on ordinary electric lighting circuits, either with continuous or alternate currents. Compared with the secondary circuit of a Ruhmkorff induction coil, or with an influence machine, the voltages of such circuits are low and are quite incapable of starting the discharge in a tube of practicable length, though, when once started, the discharge can be maintained by the low voltage for an indefinitely long period. The conditions therefore resemble those of the ordinary carbon arc, in which it will be remembered (*see* page 243) that until the carbons have been brought into contact and separated the arc cannot be “struck.”

But there are other methods available for starting the arc in the case now under consideration.

First of all, however, the ordinary and obvious method of bringing the electrodes together and then separating them can be applied, but was not the first to be used. In this, which may be called the "contact" method of striking the arc, advantage is taken of the mobility of mercury electrodes. Imagine a short horizontal tube with a little vertical tube or cup at each end containing mercury in contact with a wire sealed through the bottom of the cup. By tilting the tube the two portions of mercury in the cups can be run together to form a metallic conducting bridge, through which the circuit is made and the current passes. It is



Fig. 660.—Cooper-Hewitt Mercury Vapour Lamp.

practically a short circuit, and must therefore only be allowed to last momentarily; on restoring the tube to the original position the short circuit is broken and the arc is "struck."

Fig. 660 shows a form of the Cooper-Hewitt lamp in which this simple method is used. The lamp consists of a glass tube about 20 inches long, with conducting wires sealed into each end. Some

mercury is placed in the tube to form one electrode and to supply the necessary vapour. The tube, before being finally sealed up, is exhausted to the point at which the best effect is produced, and it is then mounted as shown so that it can be readily tilted. To start the current the lamp is tilted carefully so that the mercury flows in a narrow stream from one electrode to the other. As soon as the stream of mercury reaches the distant electrode the circuit is completed and the current starts. Almost immediately the mercury thread breaks, and the current then passes as a vacuum discharge, filling the tube with incandescent mercury vapour.

Many lamps of different shapes and for different purposes have been devised to use this method of starting the arc. Some of these will be described later in the technical section.

It is now generally recognised that conduction in the electric arc mainly, if not entirely, consists in the carrying over of charged particles, corpuscles,



or electrons from the kathode or  $-^{\text{ve}}$  electrode to the anode or  $+^{\text{ve}}$  electrode, and that the above process of striking the arc merely fills the space between the electrodes with the necessary "ionised" carriers, the supply of which is easily maintained when the process is once started and the right conditions of electric pressure, temperature, etc., established. With the mercury arc there are other methods of filling the space between the electrodes with the electrified carriers. One of these is to start the discharge by using momentarily from some other source a voltage sufficiently high to rupture the dielectric already weakened by the reduction in the pressure of the air. The necessity for supplying the high voltage, whether from an induction coil or other source, however, complicates the apparatus. A couple of Cooper-Hewitt lamps, with an induction coil to be used to obtain the high voltage necessary for starting, are shown in Fig. 661. In these lamps the kathode, which is of mercury, is at the bottom of the tube, and an iron anode at the top. As the ionised carriers all proceed from the kathode, the anode need not be a mercury one, but may, as in this instance, be of solid material. Iron, graphite, or nickel is usually used for this purpose.

A still more ingenious method has been devised by Dr. Weintraub, who has done much to develop the mercury vapour lamp for illuminating purposes. It depends on the principle that if a vacuum tube is provided with one kathode and two or more anodes, when a discharge is started between the kathode and one of the anodes, it will also

pass from the kathode to the other anode under suitable conditions. Dr. Weintraub, therefore, starts a short discharge in one part of his exhausted tube; this fills the tube with the necessary ionised carriers, and a discharge to a more distant anode then passes.

Three methods of starting the discharge with an auxiliary anode are shown diagrammatically in Figs. 662 to 664 respectively. In the first (Fig. 662)  $x$  is the kathode connected to the  $-^{\text{ve}}$  main,  $A$  is the ordinary or working anode, and  $c$  the starting anode;  $c$  and  $k$  are cups



Fig. 661.—Cooper-Hewitt Lamps, with Induction Coil.

filled with mercury, whilst A is a graphite electrode. Between c and K is a battery or other continuous current generator  $G_2$ , in series with a steadying resistance  $R_2$ , and with its —ve terminal connected to K. On tilting the tube slightly the mercury from K completes a circuit inside the tube,

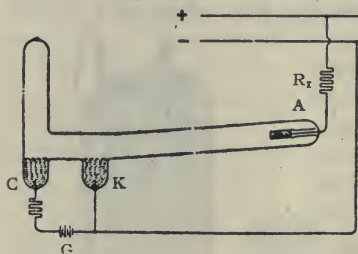

Fig. 662.—Method of starting a Mercury Arc.

In Fig. 663 the procedure is simplified by using the same source of electrical energy for both circuits; that is, by placing the auxiliary circuit B K and its resistance  $R_2$  on the mains as well as the principal circuit A K. On starting up, by first tilting and then restoring the tube, the connection is established between B and K, and immediately afterwards broken, thus "striking" the arc which then almost immediately forms between the main anode A and K, filling the tube with glowing vapour. The circuit through  $R_2$ , B and K can then be broken by opening a switch not shown in the figure.

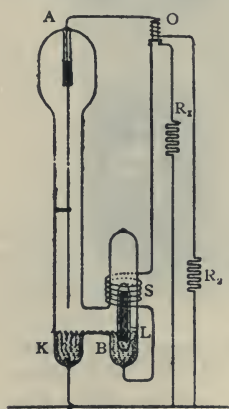

Fig. 664.—Plunger Method of starting a Mercury Arc.

The third modification (Fig. 664) is still more ingenious, and has the advantage of being automatic. A plunger L of iron floats in the mercury of the auxiliary anode B, and is so adjusted that when no current is passing there is a thin layer of mercury joining B to K. When the current is switched on the solenoid S surrounding L draws L upwards and the connecting film of mercury flows into B, thus breaking the auxiliary circuit and starting the discharge between B and K; if the lamp be properly adjusted the main arc A K immediately forms. The current of the main arc flows through the resistance  $R_1$  and the magnetic cut-out O, which, of course, has inductance and acts as a choking coil. When

on breaking which, by bringing the tube to its first position, the discharge is started between c and K. It immediately starts between A and K also, the current for this discharge being provided by the mains from  $G_1$  through the steadying resistance  $R_1$ . The switches of the auxiliary circuit c K can then be opened and the lamp will continue to burn.

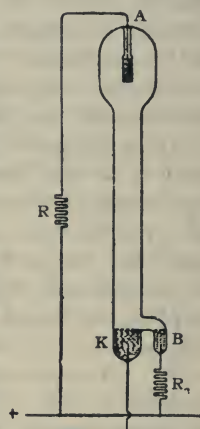

Fig. 663.—"Sidebranch" Method of starting a Mercury Arc.

the current reaches a certain value the cut-out acts and breaks the auxiliary circuit through  $R_2$ ,  $s$  and  $B$ , which is then no longer required.

The method of starting the arc by an auxiliary or starting anode is only successful when the vacuum is exceedingly good. To improve the starting conditions, a high resistance carbon filament is hung from the working anode  $A$ , thus shortening the distance between the anode and the kathode. Through this short distance the arc is more readily started, and when once established the greater part of the current flows through the tube from  $A$  to  $K$  because of the low resistance of the tube relatively to the filament.

When the arc is in operation mercury vapour is carried from the kathode towards the anode, which in Figs. 663 and 664 is shown surrounded by a chamber larger than the cross-section of the tube. In this chamber the mercury condenses, and in due course returns down the vertical tube to the kathode. The minimum current for stability is about 3 amperes; the maximum depends on the cross-section of the tube and the size of the condensing chamber, which must be kept at a sufficiently low temperature. If a reactance be placed in series with the arc the minimum current can be reduced to a few tenths of an ampere. The voltage required depends also on the length and cross-section of the tube and the back E.M.F. at the electrodes. An ordinary tube some 4 or 5 feet long will absorb about 80 volts, and with a steady resistance and reactance can be readily run upon a 110-volt circuit.

*Modifications for Alternate Currents.*—With alternate currents the phenomena are more complicated. No matter how large the current may be the arc which is formed when the electrodes are separated, even when these electrodes are both of mercury, very rapidly dies out. Of course, with alternate currents each electrode becomes a kathode for half a period, and for the next half-period the other electrode is the kathode. Moreover, the current has all values, from its maximum to zero, and although the production of ions may be quite sufficiently copious whilst the current is well up on the current curve it must sink to zero with the current, and there must be a period during which the magnitude of the current is too low to produce a sufficient number of ions for its own maintenance. Even with rapid alternations and large currents this period would appear to be sufficiently long for the ions produced to become, as it were, exhausted, and for the tube to be found, on the reversal of the current, not to contain a sufficient number of ions to start the arc in the opposite direction. Hence the arc initially formed dies out.

Some method must therefore be found for keeping up the supply of ions during the periods of small currents; in other words, one or both electrodes must be kept "alive."



Two ingenious methods of doing this, both given by Dr. Weintraub, are shown in Figs. 665 and 666. In Fig. 665 A and A' are both anodes which are connected to the ends of the secondary of a single-phase transformer T, the middle of the secondary being joined to the mercury cup K which is to be the kathode. There is a third anode B which is joined to the  $+$  terminal of a suitable continuous current generator H, whose negative terminal is connected to K, and when the action is once started a continuous current flows through the vacuum tube from B to K. This auxiliary current keeps K alive to supply the necessary ions for the more important currents from the transformer. From their electrical position it is evident that A and A' become successively  $+$  to K, and as each of them assumes this condition the ions present enable a current to flow from it to K, which can only act as a kathode. The current flowing is therefore a pulsating uni-directional current, the half-waves in the other direction towards A or A' being suppressed.

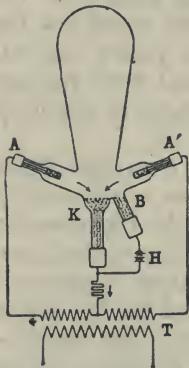

Fig. 665.—Connections for A.C. Mercury Lamp.

The method shown in Fig. 666 is still more ingenious, and does not require a transformer. The single-phase mains M are bridged by two reactances R and R' in series, the common point of the two being joined to the mercury in the cup K which is to act as a kathode. The mains are also connected directly to the anodes A and A'. The auxiliary continuous current circuit through B and K is only used to start the action, and is switched off when the main currents get under weigh. Assuming the action to have been so started, consider what happens during the latter part of the half-period when A is acting as an anode to the kathode K. As the current dies away the reactance R by its inductive E.M.F. keeps up the potential difference between A and K, and if the value of the inductance of R be properly calculated the P.D. so produced will be sufficient to maintain the flow of current from A to K until A' comes into action. In this way the supply of ions is maintained, and K is kept alive.

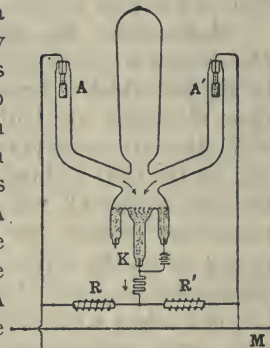

Fig. 666.—A.C. Mercury Lamp directly connected to Mains.

*Colour of the Arc.*—One of the greatest drawbacks of the mercury arc when used for general illumination is the colour of the light. The spectrum of mercury consists of two very bright lines in the green and blue respectively, and some fainter lines of which two characteristic ones lie close

together in the greenish-yellow. The general effect of the light is therefore a vivid green, with practically an entire absence of yellow and of red. The values of the colours of all objects illuminated by it are completely changed. Thus, light polished oak or varnished pitch pine appear green, and the appearance of the human face is peculiar and rather ghastly.

Various devices have been proposed for supplying the missing red rays by introducing the vapours of other metals, and experiments have been made on the production of metallic vapour arcs in an exhausted space with metals other than mercury. The metals and alloys of low melting point, which have been most used, are, of course, not liquid like mercury at ordinary temperatures, but by using some of the devices similar to those already described for starting the arc it has been found possible to produce and maintain an arc. The metals hitherto used have been the alkali metals and their alloys with lead, tin, cadmium, bismuth, zinc, etc., the character of the light emitted being dependent on the particular metallic vapours present in the tube.

**Stratification of Electric Light.**—The positive light does not always appear as an uninterrupted glow, but at certain pressures is arranged in layers, or striæ, differing in width and intensity. The striæ appear at the anode, and, both in pure gases and in mixtures, at first increase in number with the exhaustion. Fig. 658 (page 672) represents a tube filled with carbonic acid gas under a pressure of 0.08 to 0.12 inch of mercury. The brush light, which is green, seems divided into regular discs, having their hollows facing the anode. The glow light round the kathode is lavender-blue, and consists of several bright layers. In tubes containing carbon compounds a bright shining spot is often observed at the anode, from which the layers of light seem to take their origin. Mercury vacuum free from other gases gives unstratified green light, and the spectrum is that of mercury. In gases where the light is stratified the distance between the layers increases as the pressure decreases, and the revolving mirror shows that the striæ move from the anode to the kathode. Reitlinger suggested that the cause of stratification is due to the fact that the intermittent electric discharges produce impulses by which the substances forming the medium are set vibrating, the heavier substances collecting at the nodes. The separated non-conducting substances are first brought to incandescence, whilst the better conducting substances remain dark. We shall presently consider some more recent explanations of stratification.

**Magnets affect the Discharges in Vacuum Tubes.**—The effect of a magnet on light produced by currents in a rarefied space was first observed by A. de la Rive. At all degrees of exhaustion magnets act on the discharges which behave like flexible conductors. To show this, let a rod of

soft iron *s* (Fig. 667), the projecting core of an electro-magnet *D*, stand in a glass bulb *E*, and have a glass test-tube, with its edge united with *E*, placed over it. The electrodes are at *e*, and *e*, the first surrounding the glass tube pushed over *s*. The air in *E* being exhausted to about one-tenth of an inch pressure, when the two electrodes are connected with the poles of an induction coil, the usual phenomena of the vacuum tube are observed. If, however, current be passed through the coil *D*, *s* becomes a magnet, and the light at once begins to rotate about *s*. The direction of rotation round the magnet is the same as that of rigid conductors sufficiently free to move.

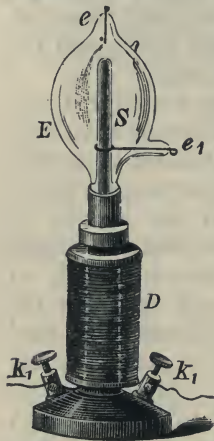

Fig. 667.—Rotation of Light: about a Magnet in a Vacuum Tube.

Plücker and Hittorf studied the effects of magnets on discharges in rarefied gases, and found that the behaviour of the cathode glow light differs from that of the anode brush light. If, for instance, a Geissler's tube, with a well-developed glow light, as in Fig. 659, be placed with its cathode between the poles of a magnet, the glow light assumes the shape shown in Fig. 668. In this plane of light (named after its discoverer Plücker's plane) the glowing particles behave as paramagnetic bodies, and arrange themselves exactly like iron filings. The anode brush light shows an almost opposite behaviour when brought between the poles of a magnet which are equatorially arranged, being pressed against one of the sides of the tube, according to the direction of the current and position of the magnets. If tube and magnets be as in Fig. 669, the light assumes the position indicated, which may be easily explained by the usual rules for the action of magnets on currents.

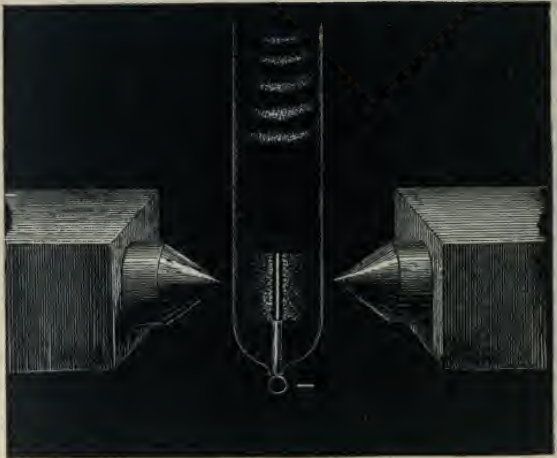

Fig. 668.—Magnet and Vacuum Tube.

The striæ are pressed against the near side of the tube near the north pole, and against the far side near the south pole. Dr. Urbanitzky and Reitlinger succeeded in causing the brush light to place



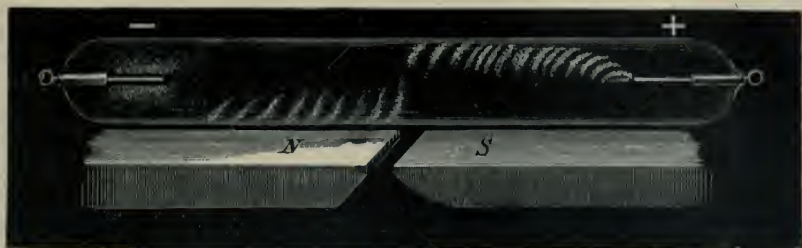

Fig. 669.—Effect of a Magnet on a Vacuum Discharge.

itself at right angles to Plücker's plane. Magnets also affect the formation of the striæ. Gassiot observed that a magnet produces stratification in a tube where there has been none. According to Wüllner, a magnet, brought near a tube containing stratified light, produces new layers, commencing at the anode.

**Discharges in Higher Vacua.**—The phenomena described so far refer to electrical discharges through spaces in which the pressure is from  $\cdot 04$  to  $\cdot 08$  inch. If the exhaustion is carried a little further, say to about  $\cdot 001$  of an atmosphere ( $\cdot 02$  or  $\cdot 03$  inch), a faint image of the glow light appears surrounding the anode (Fig. 670). Outside this, at the positive end, *b*, there is a faint light, and next comes a ball of light well separated from the anode. In the middle of the tube the brush light divides along the side passages, as shown in the figure, and nearer to the negative end it breaks up into a series of irregularly shaped patches. The ball-shaped glow suspended in the middle of the tube almost irresistibly suggests ball lightning on a very small scale. Repulsion was strongly marked when a conductor (here a brass ball, shown in Fig. 671) was brought within 4 to 8 inches. The brush light moved as far back as it could. The similarity of this phenomenon to comets, which leave a well-developed tail behind them (*see* Henry's comet, Fig. 672), confirms the view which has been maintained by Newton, Olbers, Bossel, Faye, Plana, and others, that the tails of comets undergo a real or apparent repulsion by the sun; and Urbanitzky and Reitlinger think the force of repulsion between the sun and the comet's tail explained by their experiment, shown in Fig. 671, which was verified by a series of other experiments.



Fig. 670.—The Ball-shaped Glow.

**Discharges in High Vacua.**—When exhaustion is carried still higher, and the pressure approaches the one-millionth of an atmosphere, the dark space round the negative electrode becomes larger and larger until finally it occupies the whole tube, the striæ and other appearances being apparently driven away. The progress



Fig. 671.—Repulsion of Glow by a Conductor.

of this interesting phenomenon is well shown in Fig. 673, in which the two small electrodes at the ends of the tube are connected with the positive pole P, and the middle electrode, which is of the same size as the cross section of the tube, is connected with the negative pole N of an induction coil. The dark space spreads to the right and left of the kathode N; bordering on it we find the kathode light, and the fluorescent and phosphorescent phenomena which always appear when electrical discharges are sent through Geissler's tubes.

Many beautiful effects are produced by the richness of the fluorescent rays contained in the light of these discharges. Tubes having no great rarefaction, but made of uranium glass, or surrounded with a solution of quinine or fluorescent liquid, show the effects when the glow light is well developed. But with higher exhaustion glass itself is phosphorescent. Frequently a beautiful green fluorescence is observed to surround the space of the anode light, which slowly decreases in luminosity towards the kathode light. Beyond the dark space where the brush light begins no fluorescence is observed, owing perhaps to the slight luminosity of the brush light compared with the more luminous glow light. Again, in tubes highly exhausted,



Fig. 672.—Henry's Comet.

where the kathode light shows very little luminosity on account of the greater rarefaction of the medium, very bright green phosphorescent\* light may be observed close to the space near the kathode; by means of magnets

\* By fluorescence is understood the conversion of rays of higher refrangibility into rays of lower refrangibility. By phosphorescence is meant the self-luminosity of a body.

this bright green light may be brought to arrange itself in two lines. At very high exhaustions the whole of the glass phosphoresces.

In Fig. 674 the negative electrode consists of a disc, the positive electrode of an ordinary wire. The tube is so far exhausted that no light is to be seen in it, the discharge apparently going along the sides of the tube, *i.e.* in the form of a hollow cylinder. If now this tube be brought between the poles of a magnet  $N S$ , an oval phosphorescent ring appears, of the size of the cross section of the hollow cylinder. The magnet here appears to have diverted the cylindric discharge and brought it to the section between the poles.

Before describing other phenomena which are manifested during electric discharges through high vacua,

it will be well to consider briefly the change in the state of the gas itself which such high exhaustion may be expected to produce. According to modern views, a gas at atmospheric pressure consists of a great number of molecules crowded together, but all incessantly moving about with many different velocities, the average velocity being fairly high:

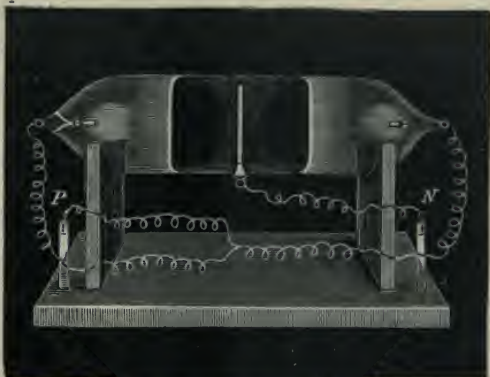

Fig. 673.—The Dark Space at the Negative Pole.

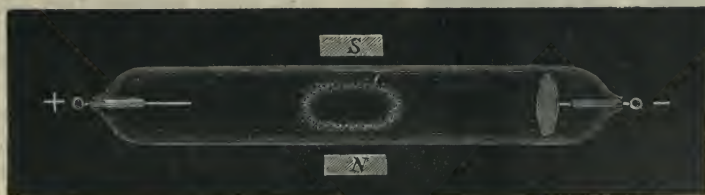

Fig. 674.—Action of a Magnet on a Discharge in a High Vacuum.

The pressure on the sides of the containing vessel is due to the continuous bombardment of these moving molecules, any one of which, however, because of the great number present, cannot move very far without colliding with another molecule or striking the sides of the vessel. In other words, what is known as the "mean free path" is very short:

When, however, we pump out the greater portion of the gas, and the pressure falls to about one-millionth of its initial value, it is evident that



the freedom of motion of the remaining molecules is enormously increased, the collisions become much less frequent, and the "mean free path" is considerably lengthened. The effects produced by passing the electric discharge through such a highly rarefied gas are so distinct from anything we obtain in air or gas at ordinary pressure that, in the words of Sir William Crookes, "we are led to assume that we are here brought face to face with matter in a fourth state or condition, a condition as far removed from the state of gas as a gas is from a liquid."



Fig. 675. — Phosphorescence in a Vacuum Tube.

To examine these phenomena tubes constructed as in Figs. 675 or 676 are useful. In Fig. 675, due to Puluj, the pear-shaped highly exhausted bulb has two circular discs as electrodes placed in the narrow neck. The kathode *K* is placed below the anode *A*, and when they are connected to the poles of an induction coil the body of the tube remains dark, but a ring of phosphorescent light appears at *P*, and is entirely outside the shadow which the anode *A* would cast if placed as an obstacle in the paths of bodies proceeding in straight lines from the kathode *K*. When the early editions of this book were written some years ago it was supposed that these bodies were either particles torn off the kathode and projected in straight lines through the nearly empty space, or, according to Crookes, that they were the molecules of the gaseous residue electrified negatively by contact with the kathode,

and then repelled with a greatly increased velocity. It should be observed that a small piece of diamond fixed at *D* glows with a soft blue light, which Crookes considered as probably caused by the reflected particles of the repelled gaseous molecules.

The experiment in Fig. 676, due to Crookes, is still more striking. The kathode *a* is a cup-shaped piece of aluminium at the narrow end of the bulb, and in the middle is a cross *b*, cut out of sheet aluminium and placed so that the rays from the kathode projected along the tube will be partly intercepted by the aluminium cross, and will project an image of it on the hemispherical end of the tube, which is phosphorescent. The black shadow of the cross is seen on the luminous end *c d* of the bulb, and may

reasonably be supposed to be caused by matter projected from the negative pole which passes by the side of the aluminium cross and causes the glass exposed to its bombardment to phosphoresce; the glass is hammered and bombarded till it is appreciably warm, and at the same time another effect is produced on the glass by this molecular bombardment which prevents the glass from responding easily to additional excitement, *i.e.* its sensibility is deadened. But the part which the shadow has fallen on is not tired, it has not been phosphorescing at all, and is perfectly fresh; therefore, if we throw down this cross (which can easily be done by giving the apparatus a slight jerk, for it has been most ingeniously constructed with a hinge), and so allow the rays from the negative pole to fall uninterruptedly on to the end of the bulb, suddenly the black cross changes to a luminous one, because the background is now only capable of phosphorescing faintly, whilst the part which had the black shadow on it retains its full phosphorescent power. After a period of rest the tired glass partly recovers its power of phosphorescing, but it is never so good as it was at first.

In more recent experiments, and by using idle poles at different distances from the electrode, Crookes showed that the stream of molecules is negatively electrified, though his results at first were puzzling because of the development of positive electrification on the glass due to the friction of the molecules.

That there is an actual stream of matter was proved long before by the conclusive experiment of setting up in its path little vanes free to rotate. Fig. 677 represents a more complicated piece of apparatus devised by Crookes to illustrate a further consequence of his theory that the moving particles are material and part of the gaseous residue. If these particles are continually repelled in straight lines from the negative electrode, then unless they find their way back again the phenomena must sooner or later come to an end. The case, however, is similar to that of the heating of a kettle of water by a flame placed under the centre of the base. A continuous stream of heated molecules passes up the centre of the vessel, to return downwards by the sides to supply the places of those subsequently heated.

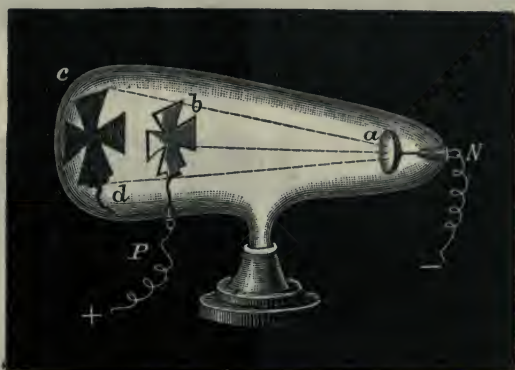

Fig. 676.—Kathode Rays cast a Shadow.

In Fig. 677 the rarefied vessel is divided into two parts by a glass screen C, pierced with two small holes at D and E. The negative electrode A' is

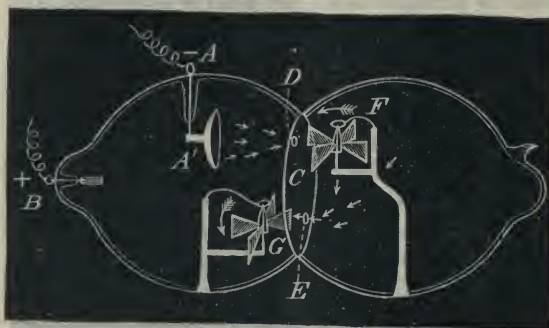

Fig. 677.—The Return of the Gas Molecules.

concave, and is so placed that its focus is at the hole D. Behind this hole the little mill F is placed so that its movable vanes can come successively opposite D. On passing the secondary discharge, this mill rotates, as we have already explained. But opposite the hole E is another little mill G, whose

vanes also rotate, showing that a current of matter is passing through E from right to left.

This experiment tends to prove, though not conclusively and exclusively, that the moving particles are those of the gas, and not particles torn from the electrode. Professor Crookes, however, carried the experimental support of his theory much farther. He showed that the effects are the same whether the electrode is made of a



Fig. 678.—Phosphorescence with External Poles.

non-volatile or a volatile metal, and in the latter case that the metal torn off can be intercepted quite close to the electrode, the "radiant matter" proceeding to a distance alone and producing its peculiar effects. Finally, he produced all the phenomena of vacuum tubes with the electrodes *outside the glass*, and therefore in such a position that no metal could be torn off them.



In Figs 678 to 682 we illustrate a few only of his experiments. Fig. 678 shows a bulb containing some pure yttria and a few rubies; these lie over the positive electrode B, and opposite the negative one A, both electrodes being outside the bulb. When the pressure is 0.9  $M^*$  the yttria and rubies phosphoresce brilliantly under the molecular bombardment.

Fig. 679 is a repetition of the experiment of Fig. 676, but in this case the electrodes A and B are again outside the glass. Finally Fig. 680 shows the production of mechanical motion in a vessel with external electrodes. The little wheel in the centre is made of aluminium with vanes of transparent mica; these vanes come successively into the focus of the negative electrode A, and when the current is passed the wheel rotates in the direction shown by the arrow. On reversing the current and making B negative, the rotation is also reversed. In this case the pressure was 1.3  $M$ . Professor Crookes also showed that the radiant matter particles are not torn off the inside of the glass in these tubes.



Fig. 679.—“Radiant Matter” Shadow.  
(External Electrodes.)

**Kathode Rays.**—In 1879 Crookes ascribed the phenomena which we have just been

describing to the existence in the exhausted tube of matter in a fourth or “ultra-gaseous” state, to which he gave the name of “radiant matter.” Much more recently it has been customary to speak of the “kathode rays,” a title which has the advantage of being purely descriptive of the phenomena, and not committing the user to any particular theory of the constitution of the rays.

Before discussing the probable nature of these rays, it will be convenient here to summarise briefly the experimental facts as known at present, and for which any theory which may be put forward must account. The most

\* The symbol  $M$  stands for a pressure of *one-millionth* of the standard atmospheric pressure of 30 inches of mercury.

striking fact is (i.) that the rays, if undisturbed, proceed in straight lines and are intercepted by objects placed in their paths, definite shadows being cast by such objects (*see* Figs. 676 and 679). Secondly we note (ii.) that where the rays strike glass and many other bodies they excite luminosity or phosphorescence ; in other words, they set the particles of the body which they strike vibrating with a periodicity corresponding to that of light waves. Then (iii.) if the kathode be curved so as to have a "focus" for rectilinear rays, objects placed at this focus are heated. Careful measurements have shown that the heat produced is *proportional to the current* passing through the tube, and not to the square of the current, as in conduction through an ordinary solid resistance.



Fig. 680.—Mechanical Motion produced by Radiant Matter.  
(External Poles.)

Next (iv.), if two kathode streams are converged on a point, they repel one another. Crookes showed this in 1879 with a tube (Fig. 681) having two kathodes, in front of which was a mica screen pierced with two small holes, one opposite each kathode, thus reducing the rays from each to a narrow pencil.

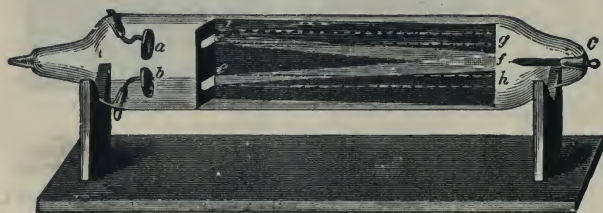

Fig. 681.—Mutual Repulsion of two Kathode Streams.

were rendered visible by a phosphorescent screen placed so that it was just grazed by the paths of the pencils. On connecting either kathode separately to the circuit the pencils took the direct paths shown by *df* or *ef*. When, however, both kathodes were placed simultaneously in circuit the pencils took the paths *dg* or *eh*, thus apparently repelling one another in the same way that similarly electrified bodies repel one another:

A kathode pencil is also (v.) deflected by a magnet as shown in Fig:

682, where the pencil, which should travel horizontally along *ef*, is deflected along *eg* when the electro-magnet *N* is excited. A still more curved path is obtained by heating sticks of potash placed in the tube, thus diminishing the vacuum.

Further, the stream appears (vi.) to pass through certain materials, more particularly through alu-



Fig. 682.—Kathode Stream Deflected by a Magnet.

minium. This was shown by Lenard in 1894 with a tube constructed as in Fig. 683. The kathode *K* is a thin aluminium disc, and the anode is a brass cylinder *A A* surrounding the leading in wire, and a little behind the kathode. Facing the latter the tube has a flat end closed with a thick metal cap, in which is a small hole closed with a thin aluminium

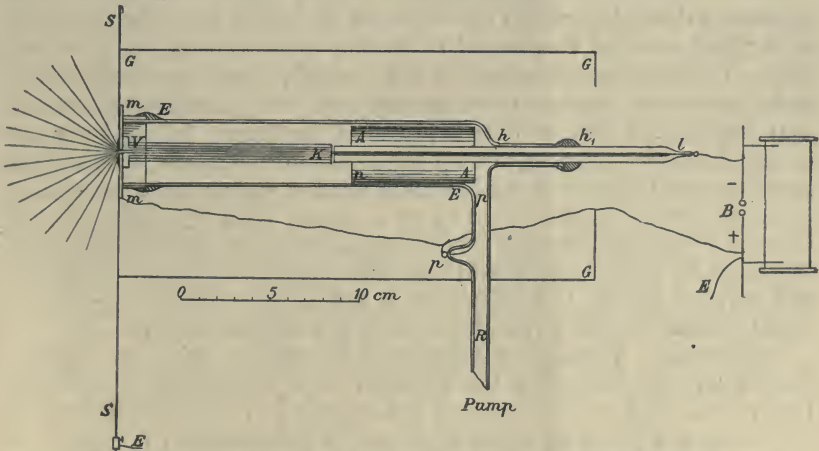

Fig. 683.—Lenard's Experiment on the passage of Kathode Rays through Aluminium.

sheet *m m*, cemented on so as to be air-tight and metallically connected with the anode. When the tube was excited a faint bluish glow was seen in the air, extending for about two inches in all directions from the aluminium window.

Finally (vii.), the velocity of the propagation of the rays has been determined by Professor J. J. Thomson, and has been found to be 124 miles ( $2 \times 10^7$  cms.) per second, which is less than one-thousandth of the velocity of light.

To explain the above experimental facts several theories have been



advanced: Wiedemann and Lenard suggested that the kathode rays were very short transverse waves in the ether, similar to the waves of light: This hypothesis is rendered untenable by the low velocity (vii.), the deflection by a magnet (v.), and the mutual repulsion (iv.) of the streams. The two last-named also render untenable a theory put forward by Jaumann that they are longitudinal waves in the ether:

**Electrons.**—The most probable hypothesis, and one which so far accounts for all the known facts, is that originally put forward by Crookes in 1879, modified in accordance with the result of researches by Sir J. J. Thomson and others. If we assume that the rays consist of negatively charged particles projected from the kathode, which is itself negatively charged, most of the above facts are explained. Such particles could not proceed far in an ordinary vacuum tube without meeting crowds of gaseous molecules, which would retard their motion. But in the highly rarefied space in the kathode ray tube much greater freedom of motion is possible, and the "mean free path" will be considerably longer. The particles would then proceed in straight lines with the enormous velocity of 124 miles per second, with which velocity they would strike any solid obstacle placed in their path. In these circumstances it is not surprising that they should set the molecules of the obstacle vibrating and give rise to phosphorescence, or that they should heat an object placed at the focus. In the latter case we should expect the heat to be proportional to the charge of the rushing particles, and therefore to the current instead of the square of the current. Any such stream would be acted on by a magnet (Fig. 682), and two such streams of negatively charged particles would repel one another (Fig. 681). Moreover, by a direct experiment originally devised by Perrin and modified and repeated by Sir J. J. Thomson, it has been proved that there is an actual transfer of negative electrification in the kathode stream.

So far, there is one great difficulty in the theory which has not been alluded to. Assuming for the moment, as Crookes originally assumed, that the particles are molecules of the residual gas, why should they not also be charged positively at the anode and be projected from it, giving rise to a similar set of phenomena there? The matter was carried farther by the determination by Sir J. J. Thomson of the mass of the electrical carrier in the kathode rays. He first experimentally determined the ratio of the mass of the carrier, assuming that it is a material particle, to the charge carried; next, the charge itself was determined experimentally. The result was surprising, for it was found that the mass was considerably less than the mass of the lightest atom known to the chemist—viz. the hydrogen atom. As corrected by subsequent measurement, the mass of this electricity carrier, or ion, to which Professor Thomson gave the name of "corpuscle," is about  $\frac{1}{700}$ th of the mass of the hydrogen atom. If these inferences be correct (and the evidence in their favour is very strong), the atom which

cannot be divided by chemical methods can by electrical methods have detached from it these small negatively charged bodies or "electrons," as they are now called. Whether the electrons are very small portions of matter electrically charged or are *atoms of electricity* itself, has not yet been determined. If the latter, then we are back to Franklin's one-fluid theory of electricity, the actual fluid being what we are accustomed to regard as negative electrification. By detaching electrons from a neutral molecule it becomes, on this theory, positively charged, whereas an excess of electrons constitutes a negative charge. Whether this be so or not, experiment with *radio-active bodies* (see page 706) shows that positive charges cannot be similarly detached, and that although the unit positive charge is equal to the unit negative charge (the "electron"), the ion which carries it has enormously greater mass than the negative ion, and is probably never less than a full-sized atom. This throws light on Faraday's experiment (page 659) on the length of electric sparks in air, and also on the transfer of metal from the  $+$  to the  $-$  electrode of a spark discharge.

Only one of the above experiments—viz. No. (vii.)—has been left unexplained. It need not detain us long. The cathode rays, after apparently passing through the aluminium window, do not pursue their course in the same straight line as before, but are diffused in all directions as if proceeding from the outside of the window as a source. It would therefore seem that they are not the same rays as those which fall on the inner side of the window, and the phenomenon can be explained by assuming that the latter by the impact of the electrons render the aluminium radio-active, thus causing other electrons to be detached from the outer surface.

**Explanation of the Dark Space and of Stratification.**—The electron theory also supplies a very plausible basis of explanation for the phenomena of vacuum tubes at lower exhaustions (Fig. 671 *et seq.*) which have long puzzled physicists. In this connection a more recent experiment by Crookes is suggestive. Figs. 684 and 685 show the appearance of the same vacuum tube at different exhaustions. The tube is filled with hydrogen gas, but contains some mercury vapour from the pump. In Fig. 684 the pressure is 4 mm. of mercury, and the striæ consist of buttons with blue faces towards the cathode and pink faces towards the anode. Examined spectroscopically, the pink faces gave strong hydrogen lines only, and the blue both hydrogen and mercury lines. At 2 mm. pressure (Fig. 685) the blue appearance migrated to a single button in front, which showed only the mercury lines and a series of pink buttons nearer the anode, these showing only the hydrogen lines.

Now for the explanation. The swiftly-moving electrons leaving the cathode sweep back the much heavier but more slowly moving atoms of hydrogen and mercury until the latter are so crowded together that they can stop a fair proportion of the electrons. In this process the heavy

mercury atoms are not driven so far back as the lighter hydrogen ones. Where the stoppage takes place, then, is a kind of battle ground, and the heavy material atoms are set in rapid vibration by the bombardment to which they are subjected, thus becoming luminous and giving out those fundamental vibrations which are characteristic of them, and which can

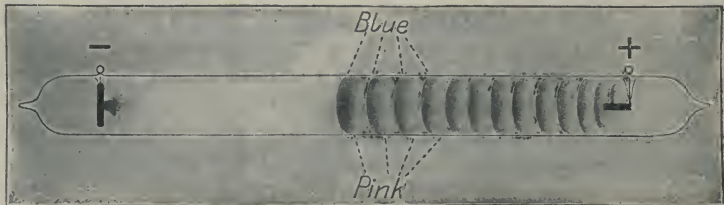

Fig. 684.—Mercury and Hydrogen Stratifications.

be analysed in the spectroscope. We thus get the first bright button of Fig. 684 with its blue face and pink back. The electrons, doubtless now entangled with some gaseous particles, rush on, but with diminished energy, crumpling up the next battalion of gaseous atoms and molecules, and repeating the process to form the second button, which is close behind the

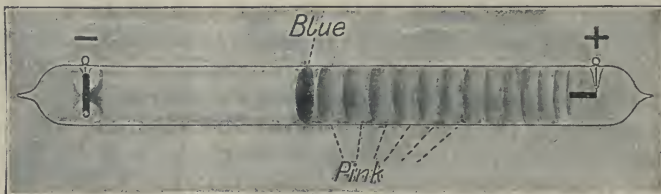

Fig. 685.—The same in a Higher Vacuum.

first, and so on for succeeding buttons, each of which is fainter than its predecessor.

In Fig. 685 the atoms and molecules present are reduced to one half those in Fig. 684. Here, then, the light hydrogen molecules (the mercury atom has nearly 100 times the mass of a hydrogen molecule) are completely swept out of the space where the heavy mercury atoms receive the first onslaught of the electrons, and thus the first button is bright blue only. Subsequent buttons consist of vibrating hydrogen only, probably because after the first mercury button there is not enough energy in the electrons which pass on to set the heavy mercury atoms in vibration with sufficient vigour to set up waves of light in the ether.

**Röntgen or X-Rays.**—In November, 1895, Professor Röntgen announced to the Würzburg Physico-Medical Society a discovery which has



proved so epoch-marking that it has led to the foundation of a new branch of electrical science which already boasts a very considerable literature. The discovery was that the rays from a Hittorf tube designed to give kathode rays caused phosphorescence or fluorescence of some flakes of barium platino-cyanide, although the tube was wrapped in black paper to obscure the light. He quickly found that the exciting rays were capable of passing through much more substantial obstacles, such as boards, books, thin sheets of aluminium, etc., and that they affected a photographic plate even when shut up in the ordinary light-tight "back" or case. The most striking discovery, and the one which produced the most profound impression on the non-scientific world, was that whilst skin and flesh are comparatively transparent, bone is nearly opaque to the rays, and therefore by throwing a shadow of the hand, etc., on a fluorescent screen it is possible to "see your bones."

It was very soon proved that the new radiations differed from "kathode" rays, and as their exact nature could not be discovered at once, Professor Röntgen gave them the name of X- (or unknown)

rays. In honour of their discoverer, however, they are now frequently referred to as "Röntgen rays." They differ from kathode rays in not being deflected by a magnet, and in passing freely through the glass of the vacuum tube: They make gases through which they pass conductors, and thus discharge both  $+$ ly and  $-$ ly electrified bodies, and only to a slight extent, if at all, can they be regularly reflected, refracted, or polarised:

To produce the Röntgen rays most copiously special tubes must be used: It is necessary that the kathode rays should strike some obstacle, and Röntgen himself showed that platinum was much better than many other materials for the purpose. Mr. Herbert Jackson, of King's College, London, showed that the best results were obtained by a tube arranged as in Fig: 686, in which the anode is a flat platinum plate fixed at an angle of  $45^{\circ}$  to the kathode stream and placed in the "focus" of a concave kathode: The tube should be more highly exhausted than for the kathode rays only, and when so constructed is now known as a "focus" tube:

It is not necessary that the platinum plate should be the anode; so long as it is placed in the right position at the focus of the kathode the anode may be placed anywhere in the tube. When it is not the anode

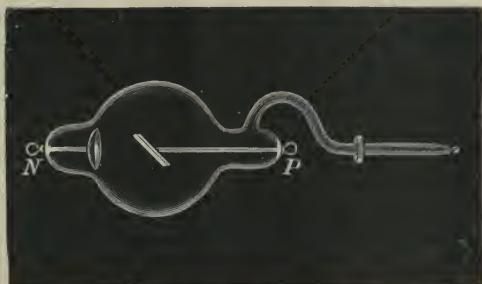

Fig. 686.—A "Focus" Tube.

the platinum plate is known as the *anti-kathode*. A tube in which the platinum can be used either as an anode or an anti-kathode is shown in Fig. 687, which illustrates a tube made by Messrs. Griffin and Sons; *a* is the kathode terminal, *c* the terminal connected to the anti-kathode, and *b* the separate anode terminal. Such tubes are very often used with the terminals *b* and *c* joined by a wire, so that they both act as anode terminals.

The tubes just described are for use with unidirectional currents. Early in 1896 Professor Elihu Thomson and Mr. A. A. C. Swinton independently constructed tubes for use with alternate currents, which are now so readily procurable from public supply mains. Mr. Swinton's tube

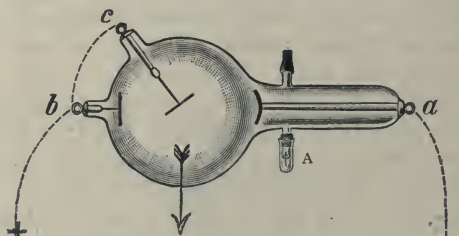

Fig. 687.—Tube with separate Anti-Kathode and Anode.

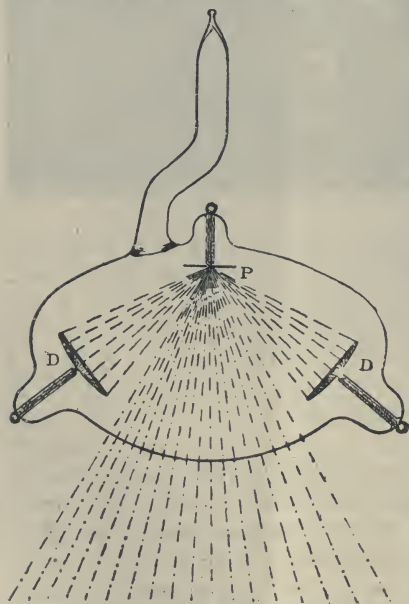

Fig. 688.—Mr. Swinton's Tube for Alternate Currents.

is shown in Fig. 688. The platinum disc *P* is used as an anti-kathode, and the concave aluminium discs are connected to the current circuit. As the current alternates each of these in turns is a kathode, and directs its rays on to the platinum plate, whence the Röntgen rays are radiated in the same direction whichever aluminium disc is the kathode. In such tubes it is very necessary to focus the two kathodes carefully on to the same part of the anti-kathode so as to secure a single radiant point.

Many patterns of tubes, some very complicated, have been devised with the object of overcoming minor difficulties in working and of adapting the radiations to special requirements. For instance, tubes have been made with movable kathodes, with several anti-kathodes, and with special devices for controlling the vacuum. These last-named devices have been found necessary because when a tube has been worked for some time the vacuum is found to improve to such an extent that the penetrative power of the rays becomes too great to give the sharp contrasts between, say,

bone and muscle, upon which the value of radiographs depends. Technically, the tube is said to become "hard." The devices for controlling the vacuum are, therefore, of practical importance, and tubes fitted with them are known as "regenerative tubes."

**Regenerative Tubes.**—One method of control is shown in Fig. 689. The tube consists of two bulbs and narrower portions. During the process of exhaustion of any Röntgen ray tube the glass is heated, when high exhaustions are being reached, so that any gases occluded on the inner surface may be driven out and removed by the pumps. In the tube in Fig. 689 this process of heating has only been applied to the bulb A containing the kathode, consequently the glass of the bulb B still contains occluded gases on its inner surface. When the vacuum of the tube whilst working has become too high, bulb B is gently heated, and some of the gases are driven off into the tube, thus reducing the vacuum.

Another ingenious method is to seal through the glass in a convenient

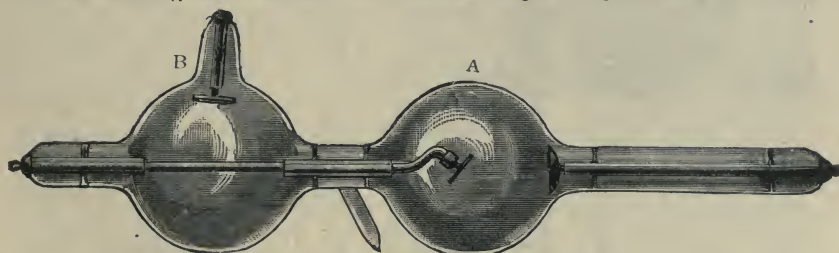

Fig. 689.—Regenerative Röntgen Ray Tube.

side tube (A, Fig. 687) a wire made of platinum, palladium, or some alloy which has the property to a very marked degree of occluding a gas such as hydrogen. When the tube becomes "hard," the outer end of this wire can be cautiously heated with the flame of a spirit lamp, from which it will absorb the gas required. By a process of transfusion, or osmosis, as it is called, the gaseous molecules are passed through the metal much as water passes through a sponge, and when they arrive at the inner surface the reduced pressure there, combined with the high temperature of the wire, causes them to pass into the vacuous space, thus increasing the pressure and reducing the vacuum.

Whatever method is used, the necessity for re-exhaustion has to be faced sooner or later, and therefore all X-ray tubes are designed so as to be easily sealed on to the pumps again. Some of the methods of obtaining the necessary high vacua have already been described (*see* pages 233 to 236).

**Radioscopes.**—The "seeing of the bones" is at once the most striking and one of the most useful of the experiments possible with Röntgen rays: For this purpose the object to be examined, say the human hand, is placed in the path of the rays, which afterwards fall upon a fluorescent screen:



Such a screen is made by spreading evenly over a sheet of paper fine crystals of certain salts, some adhesive material being used as a vehicle. The salts most used are barium platino-cyanide, used by Professor Röntgen in his early work, and potassium platino-cyanide, suggested by Mr. Jackson. A good result is obtained by dissolving the barium platino-cyanide in amyl varnish and painting the screen with the solution. The screen should be backed with thin ebonite or black paper to exclude ordinary transmitted light.



Fig. 690.—Lady's Hand. Normal.

The best method of using such screens is in a proper radioscope, which consists of a pyramidal shaped light-tight box with the screen at the wide end and a suitable eye-piece, whose sole function is to fit the contour of the face somewhat closely, so as to exclude all extraneous light. This precaution is necessary because of the faintness of the image, which can only be clearly

examined when the eyes have been well rested and no other light is present.

The kind of appearance obtained is represented in Fig. 690, which is reproduced from a radiograph by Messrs. Coxeter and Son of a lady's hand. Metal objects such as the ring and the bracelet, being quite opaque to the rays, appear black. The bones, which are only partly transparent, are clearly defined, whilst the flesh is outlined as a nebulous shadow. One important application is obvious, namely, the detection of foreign metallic bodies, such as bullets, imbedded in the flesh. For instance, we have in Fig. 691 a radiograph (also by Messrs. Coxeter and Son) of a human foot clearly showing a needle imbedded in the flesh.



Fig. 691.—Radiograph of Foot showing Needle imbedded in the Flesh.

If the effect is to be seen by several people at once the room must be very completely darkened, and even the fluorescent light from the X-ray tube obscured. The sparks of the contact breaker, if it is in the room, must also be screened. With these precautions it is quite possible to exhibit the shadows on the screen to quite a number of people at once.

Such shadows may reveal the contents of closed bags or boxes (provided the box is not made of metal) or the skeletons of living animals or parts thereof. A shadow picture of a bag containing a key, a coin, a corkscrew, &c., is shown in Fig. 692; the metallic objects are all very sharply exposed, although they are surrounded with materials opaque to ordinary light.

**Radiographs.**—It has been pointed out that the Röntgen rays not only cause the screens we have described to fluoresce, but that they act on ordinary photographic plates. The result, however, differs from an ordinary photograph, because of the non-refrangibility of the rays. In ordinary photographic work an image of the object to be photographed is formed, more or less perfectly, on the photographic plate by refraction through the lenses of the camera. But, since the Röntgen rays are not refrangible, lenses, etc., are useless, and all we can do is to throw a shadow on to the sensitive plate. All the advantage of a reduction of size and concentration of effect is therefore lost, for the shadow cannot be smaller than the object, however close the latter may be to the plate. True, having once obtained a radiograph, as it may be appropriately called, we can by photography either enlarge or diminish it. Another disadvantage in



Fig. 692.—Radiograph of objects inside a bag.  
(*Phot.: Mr. Campbell Swinton.*)

radiography due to the same cause is that perspective effects cannot be obtained, for a shadow has no perspective.

Another difficulty which gave much trouble, especially with the early experimenters, is the feebleness of the photographic action, which renders long exposures necessary to obtain a good effect. At first exposures of twenty minutes or longer were not uncommon.

Attempts were made to surmount these difficulties by photographing the shadows on the fluorescent screens. Unfortunately, owing to slight movements of the radiant point, these shadows are not perfectly steady, and as the light emitted is somewhat feeble the results are not good. The outstanding difficulties are being overcome by careful attention to small details.

Long exposure to Röntgen rays is found to give rise to serious results, and some of the early operators and demonstrators suffered rather severely in consequence. One well-known pioneer, Mr. H. W. Cox, after years of severe suffering, succumbed to the effects, and there have been several other martyrs. Methods of protection by suitable screens are now, however, well understood, and it is possible to use the distinctly valuable therapeutic effects of the rays in lupus and other skin diseases without danger to the operators. The developments in this direction are, however, beyond the scope of this book.



Fig. 693.—Radiograph of Hand.

In Figs. 693 to 696 we give some examples of radiographs. Fig. 693 is the reduced radiograph of a hand and wrist encircled by a bracelet; it corresponds to the photographic negative, and should be compared with Fig. 690, when it will be found that the light and dark portions are reversed.

Fig. 694 is a radiograph of a side view of a living head in which details of the interior do not appear because of the enclosing bony skeleton. This disadvantage does not exist with regard to the thorax, of which a radiograph is given in Fig. 695; this in the bony ribs and the sternum clearly show as against the more fleshy parts. A metal stud or button used as a fasten for clothing at the neck is very prominent.

Examples could be multiplied to any extent with varying degrees of interest. We give finally in Fig. 696 another radiograph of a hand, the interesting point being that the Röntgen rays used travelled through a sheet of black vulcanised fibre absolutely opaque to ordinary light. In this case the time of exposure was four minutes.



Fig. 694.—Radiograph of a Living Head.  
(Coxeter and Son, phot.)

Ordinary photographic films on glass or celluloid may be used, but skill and practice are required to produce good results. The feeble action of the rays is on account of their energy being only very slightly absorbed by the films. This is very strikingly made manifest by the fact that if



several films are placed behind one another they all receive the impression, and almost to the same extent, showing that the rays pass through the first ones practically unchanged. In fact, an image has been obtained on each of a pile of one hundred bromide papers exposed at the same time. The images were, of course, all negatives. Films, etc., which are not being

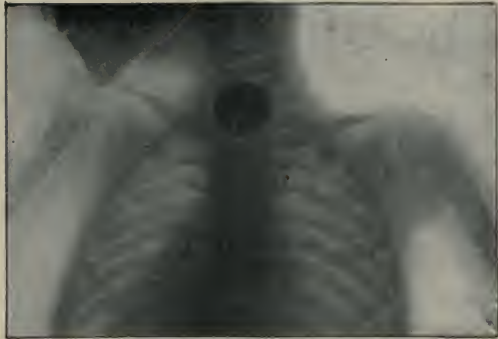

Fig. 695.—Radiograph of a Thorax.  
(Coxeter and Son, phot.)

exposed must be enclosed in metal boxes, as the ordinary light-tight cardboard boxes are useless, being quite transparent to the Röntgen rays:

*Localisation of Imbedded Bodies.*—The fact that the shadows of all

bodies in the same straight line between the screen and the radiant point appear in the same position on the screen makes it very difficult to determine the exact position of any foreign body, such as a bullet or a needle, which may be imbedded in the flesh. Many plans have been devised to overcome the difficulty. We can only here describe a fairly successful one by Dr. Mackenzie Davidson, which ingeniously makes use of the stereoscopic principle.



Fig. 696.—Radiograph taken through Black Vulcanised Fibre.  
(Phot.; Mr. Campbell Swinton.)

The apparatus as made by Messrs. Newton & Co. is shown in Fig. 697, in which *m* is an electric motor controlled by the variable resistance *r* and giving the necessary synchronous motion to the different pieces of apparatus. The idea is to energise alternately two focus tubes *A* and *B* (Fig. 698), which, with the fluorescent screen *F*, are placed on the far side of

the screen *s s* (Fig. 697). The object to be examined is placed between the tubes *A B* and the screen *F*. The opaque screen *s s* has two openings *a* and *b* side by side, which are opened and closed alternately by revolving shutters,

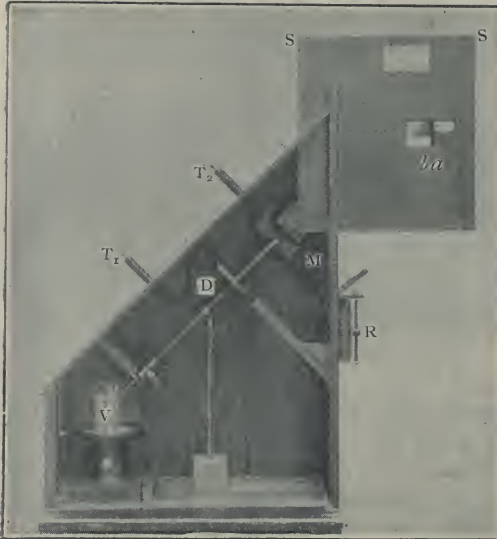

Fig. 697. — Dr. Mackenzie Davidson's Stereoscopic Interrupter.

It remains only to explain how the illumination of the tubes is made to synchronise with the movements of the two shutters. This is accomplished by the apparatus on the lower side of the motor *M* (Fig. 697). The two tubes *A* and *B* are excited by two induction coils, whose primary circuits are in parallel and connected to the terminals  $T_1$  and  $T_2$  respectively. One common end of these circuits is at the mercury in the vessel *v*, in which dips a two-bladed contact-breaker driven by the motor *M*. From these blades the current is led to a contact piece on the ebonite disc *D*, which alternately closes the circuits of the  $T_1$  and  $T_2$  terminals, as shown diagrammatically in Fig. 699, where *c* is the revolving contact joined through *x* to the circuit-breaker, and *s*<sub>1</sub> and *s*<sub>2</sub> are sliding brushes connected to  $T_1$  and  $T_2$ , and each making contact with *c* once in every revolution. The apparatus is adjusted so that when one of the circuits is closed at *c* the dipper in *v* breaks that circuit. The same thing happens half a revolution later in the other circuit. Thus the tubes *A* and *B* (Fig. 698) are alternately illuminated. As the moving

driven by the motor *M*. The right-hand opening *a* is clear when the left-hand tube *A* is excited, and the opening *b* is clear with *a* closed when the tube *B* is excited. Seen without the shutters the shadow on the screen *F* would appear to be very unsteady, for it is formed first by one tube and then by the other. With the shutters at work, however, one eye sees only the shadow formed by one tube and the other eye the shadow thrown by the other. Thus a true stereoscopic effect of solidity and depth is obtained.

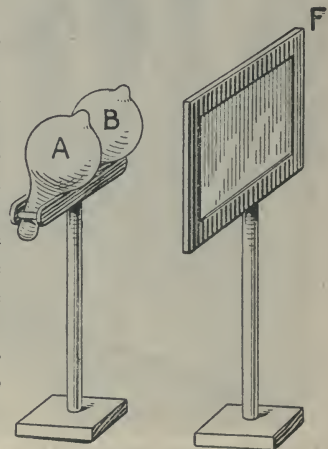

Fig. 698. — Stereoscopic Radiography.

shutters at *a* and *b* (Fig. 697) are driven by the same motor which drives the disc *D* (Fig. 699) it is merely a matter of adjustment to obtain the necessary synchronism. It is claimed that the apparatus is so effective that a bullet hidden in a loaf of bread can be touched by a probe at the first trial, for the stereoscopic effect extends not only to the loaf and the bullet, but also to the probe.

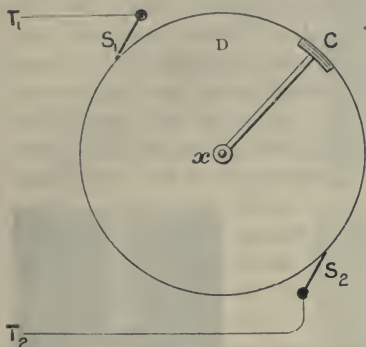

Fig. 699.—Circuit-maker for Stereoscopic Effects.

#### V.—THE BRUSH DISCHARGE IN AIR.

When an insulated conductor is brought to a high potential by means of either an influence machine or an induction coil, the conductor, if in a dark room, will be seen to be surrounded by a glow which is more especially noticeable on points and projections, as in Fig. 700. Examined carefully, it will be found that the

charge of the conductor is silently escaping by the particles of dust, etc., and the actual molecules of the air are becoming electrified and are travelling off down the lines of force. The luminous phenomena only occur when the potential is very high, but the discharge from points occurs, as previously explained (*see* page 82), at low potentials. If a very powerful influence machine be used the discharge becomes much more brilliant, and somewhat like Fig. 701. There is also a slight crackling or sizzling noise. A further modification takes place if another conductor is brought near the insulated conductor, but not near enough for a spark; for, as we should expect, the lines of force along which the electrified particles are passing converge on this conductor, and the brush gathers itself up into a bunch as shown in Fig. 702.

**High Frequency Discharges.**—Some remarkable effects were produced with these discharges by Mr. Nikola Tesla in some experiments which he undertook many years ago with the object of discovering a more economical method of illumination than any of those at present in use. In these experiments he used static transformers (*see* page 433), the primary or thick wire coil of which was supplied with currents from a specially designed high frequency alternator, the periodicity of the currents being hundreds of thousands per second. One effect is shown in

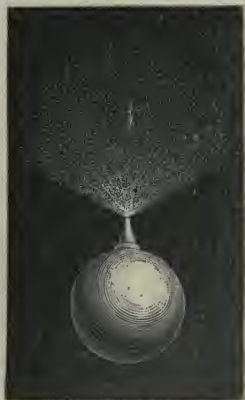

Fig. 700.—Brush Discharge.





Fig. 701.—Brush Discharge.

electric flame there would be no chemical action or consumption of material. It is thus rendered probable that the light and heat of an ordinary flame are due to electrical actions, to which the chemical changes are subsidiary, though at present necessary. The flame from one terminal is much intensified if the other terminal be joined to a point on the primary circuit as in Fig. 704. In this case it resembles the phenomenon known as "St. Elmo's Fire."

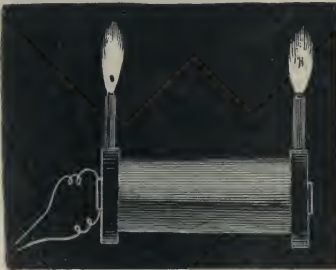

Fig. 703.—Brush Discharge from Coil.

With the transformer described at page 437 and using a high frequency alternator in the primary (thick wire) circuit, Mr. Tesla obtained brilliant streams of light by bringing the terminals of the secondary coil sufficiently close. By properly shaping the wires some beautiful effects were produced. For instance, by bending the wires into the shape of large and small circles and placing them concentrically in the same plane, the brilliant luminous disc shown in Fig. 705 was obtained. The circle *c* was about 12 inches and the circle *c* about 32 inches in diameter:

Fig. 703, in which the discharge, instead of passing directly across from one terminal to another, appears as two flames passing directly upwards from the terminals. These flames are hot, and are considered by Mr. Tesla to resemble ordinary flames more than would at first be thought possible, and would exactly resemble them if only the potential and frequency were sufficiently high. The difference would be that in the



Fig. 702.—Brush Discharge.

In subsequent researches Mr. Tesla dispensed with the high frequency alternator as a source of current, and obtained currents of much higher frequency than the above by using the discharges from the Tesla apparatus described on page 658. Brilliant sparks several inches long can be drawn by the hand from the knobs D (Fig. 640) without any personal discomfort. Their frequency is so high that the current is very nearly in quadrature with the P. D., the tangent of the angle of lag being, as we have already seen,  $\frac{pL}{R}$ ,

which is nearly infinite because of the high value of  $p$  ( $=2\pi n$ ). The current is, therefore, nearly wattless, and the amount of energy involved is very small. It is probably, however, the very high frequency which makes the spark innocuous.

If an ebonite plate covered with points be connected to D (Fig. 639), an intensely violet and copious brush discharge is obtained which has been found to have very important therapeutic properties.

The Tesla apparatus described on page 658

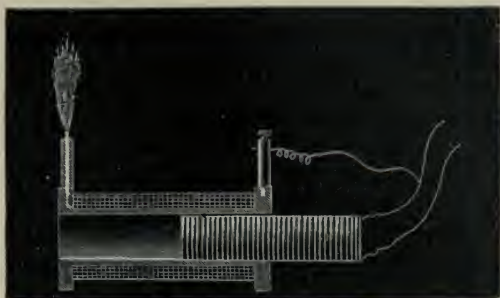

Fig. 704.—Coil producing St. Elmo's Fire.

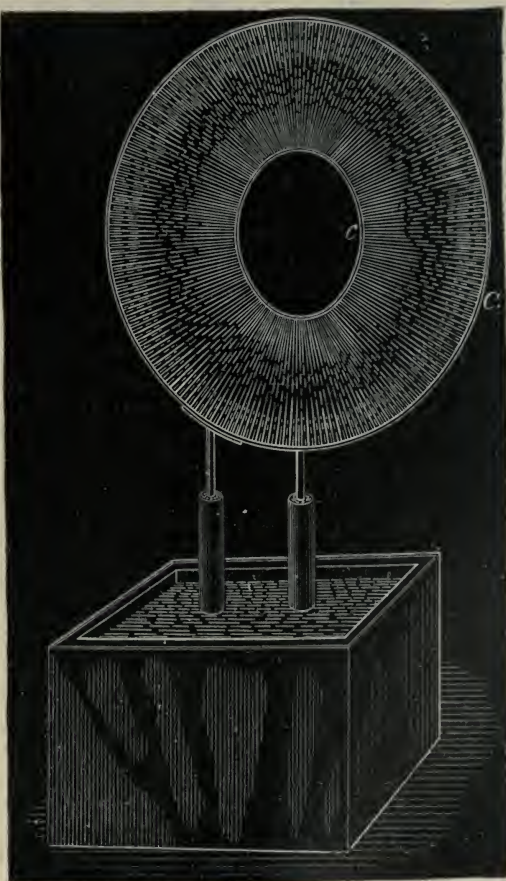

Fig. 705.—Luminous Discs.

produces an intense alternate electrostatic field in its neighbourhood, and when it is working well sparks can be drawn from any metal object in the room, and any vacuum tubes that are lying about are rendered luminous by the electric surgings set up in them.

#### VI.—THE CONDUCTION OF ELECTRICITY THROUGH GASES.

Although the "seeing of the bones" as a consequence of the discovery of the X-rays is what appeals most strongly to the popular imagination another property observed by Röntgen and briefly mentioned on page 693, is of the highest scientific importance and almost immediately had far-reaching scientific effects. This property is that "they make gases through which they pass conductors." Under ordinary circumstances gases free from dust act as perfect insulators between two bodies at different potentials until the electric pressure rises to a value sufficiently high to rupture the dielectric. Evidence, however, was not lacking, even before Röntgen's discovery, that under certain circumstances this insulating power was lost, the gas acting at least temporarily as a feeble conductor. One method of bringing about this conducting state was found in connection with ultra-violet light.

**Discharge by Ultra-Violet Waves.**—If a well-insulated negatively-charged body which would retain its charge for days under ordinary circumstances has directed on to it a beam of ultra-violet light it will be almost instantaneously discharged. It has already been explained that the ether waves which, within the limits of the visible spectrum, constitute light, extend in both directions beyond the spectrum. Those of shorter wavelength than violet light are known as *ultra-violet* waves, and have the property noted above, that they can cause a negatively-charged body on which they fall to lose its charge. They do not, however, affect a positively-charged body.

One may explain the phenomena thus:—Assuming that the negative charge is due to an excess of the light and mobile negative electrons, the rapidly-vibrating ether waves may loosen the hold of these on the charged body and attach them to the surrounding gaseous molecules, for it is found that if the discharge takes place in a closed space the contained air becomes negatively charged. On the other hand, the positive charge, being associated with the heavier material atoms and molecules, cannot be disturbed by the ether waves, and thus a positively-charged body is not affected.

**Ionisation of a Gas.**—In explaining the conduction of the electric current through liquid electrolytes (*see* page 199) it was shown that the passage of the electricity through the liquid is most readily explained by regarding the dissociated *ions* of the electrolyte as acting as carriers for



the  $+$ <sup>ve</sup> and  $-$ <sup>ve</sup> charges which, flowing in opposite directions, constitute the current. The liquid is said to be *ionised*, and the conductivity is a measure of the ionic velocity. It has been found that all electrolytes are in a permanently ionised condition, for even badly conducting liquids contain a number of ions very great in comparison with the number discharged in unit time at the electrode. It follows that electrolytes obey Ohm's law, the current being strictly proportional to the nett available voltage.

By methods of which one or two instances have been given and which will be discussed more fully presently, the particles, atoms or molecules of a gas can be made to act like the ions of an electrolyte, that is, they can become charged with electric charges,  $+$ <sup>ve</sup> or  $-$ <sup>ve</sup>, and if, when so charged, they are placed in an electric field of force, the charged particles will move along the lines of force in accordance with known elementary electrical laws, and the result will be an electric current.

The case of the gas, however, is distinctly different from that of the liquid. In a gas well screened from ionising influences it is probable that no charged ions exist. On exposure to ionising radiations ionisation proceeds throughout the whole volume of the gas exposed to the rays but only to a limited extent, the number of ions produced in unit time being a measure of the intensity of the radiation absorbed by the gas. Hence the current which these ions can produce when the space in which they exist is an electric field between two electrodes kept, by a battery or otherwise, at different potentials, is not entirely dependent upon the potential difference. If the potential difference be sufficiently high to set the ions moving with the maximum velocity with which they can pass through the gas, the current flowing will be independent of the voltage and therefore will not be in accordance with Ohm's law. The critical potential difference referred to is known as the "*saturation voltage*" and the corresponding current the "*saturation current*." For weak ionising influences under ordinary conditions about 300 volts is sufficient to produce the saturation current. When the ionising influence is withdrawn, the oppositely charged ions rapidly recombine and the gas resumes its usual non-conducting state, but even whilst under the ionising influence the tendency to recombination is always present.

For the more powerful ionising influences the currents produced can be measured with a sensitive galvanometer, but the more feeble currents which result from weaker influences have to be measured by more refined methods, the description of which is beyond the scope of the present work. We pass to the interesting methods by which gases can be made conductive and shall simultaneously consider other phenomena closely connected therewith.

## VII.—RADIO-ACTIVITY.

**Becquerel Rays.**—There is a kind of radiation, not yet referred to, which has electrical properties, and which is named after M. Henri Becquerel, who has done so much to unravel its mysteries. The researches of M. and Madame Curie were also especially fruitful in the early days.

In 1896 M. Becquerel observed that rays emitted from certain uranium salts had the property of acting upon a photographic plate through folds of black paper sufficiently thick to exclude all direct action by sunlight. This action, unlike phosphorescence, appears not to be traceable to previous exposure to sunlight, as salts prepared in the dark possess the power of influencing the plate. Further research showed that the phenomena were much more complicated than was at first supposed, and only a brief summary of the discoveries can be given here.

All bodies possessing this property are referred to for brevity as *radio-active bodies*. Pitchblende, the ordinary ore of uranium, is more active than uranium itself. It consists of an oxide of uranium ( $U^3O^8$ ) with certain impurities; amongst these are bismuth, barium, titanium, and thorium, all of which when prepared from pitchblende are radio-active though not so when obtained from other sources. The new property has been supposed to be due to the presence in each case of strange and otherwise unknown elements, some of which have actually received names. Thus the bismuth radio-activity is said to be due to the presence of *polonium*, that of barium to *radium*, and that of titanium to *actinium*, whilst indications have been obtained of the existence of a much greater number of elements, but in such minute quantities that their existence is largely a matter of conjecture and inference.

Besides affecting an otherwise protected photographic plate the Becquerel rays were early found to have the following properties:—

- (i.) They can discharge both  $+$ <sup>v</sup> and  $-$ <sup>v</sup> electrified bodies.
- (ii.) They can change, under certain circumstances, a spark discharge into a brush discharge.
- (iii.) They can excite phosphorescence or fluorescence in certain substances such as are used for screens in radiosopes (*see* page 695).
- (iv.) They can be polarised, reflected, and refracted at least partially.
- (v.) They can be deflected by a magnet.
- (vi.) They can destroy the germinating power of seeds, and they act injuriously on the skin.
- (vii.) They discolour rock salt and convert yellow phosphorus into the red variety.

(viii.) Their velocity is  $1.6 \times 10^{10}$  cms. per second; or about one-half that of light.

(ix.) Radium and actinium can cause most other bodies exposed to their influence to become temporarily radio-active.

From these complex properties it was difficult to make out what is exactly the nature of the rays. Some of them—*e.g.* (i.) partially and (iv.)—could be explained by supposing them to be ether waves of very short (ultra-violet) wave-length. Others—*e.g.* (v.) and (viii.)—seemed to negative this supposition. The theory that they consist of rays of negative electrons explains most of the properties, but is inconsistent with (iv.).

The phenomena underlying the Becquerel radiations have been found by further research to be more complicated than even the above summary would lead one to suppose, and at this stage of development, with a vast amount of work not only accomplished but still proceeding, it is exceedingly difficult to disentangle conjecture from ascertained fact. It is, however, generally agreed that in the radiations there are at least three well-defined types of rays having widely different properties. These have been named the  $\alpha$ -,  $\beta$ -, and  $\gamma$ - rays, and their *properties* may be summarised as follows:—

*$\alpha$ -Rays.*—These are distinguished by their very great ionising powers whilst their photographic effect is very feeble; and they are soon absorbed by conducting screens and by air, a few centimetres of which are sufficient for their complete absorption. Their effect on many phosphorescent screens is also very feeble, but on phosphorescent zinc sulphide it is very great. This has been taken advantage of by Sir William Crookes in designing a little instrument, which he calls the *spinthariscopes*, in which a very minute and probably unweighable quantity of radium acts upon a small zinc sulphide screen, the effect, when viewed through a lens, consisting of momentary flashes or scintillations. As each flash is probably due to the impact of a single  $\alpha$ -particle, the instrument may be said to render visible the action of a single atom of matter. The exceedingly small quantity of radium used can keep up the scintillations for years, being an illustration of the extreme delicacy of radio-active methods of investigation. In fact, such methods are far more delicate than the spectroscope, which has always been regarded as one of the most delicate instruments for the detection of minute quantities of impurities. Examined by the spectroscope, it is just possible to detect the presence of 1 part of radium mixed with 10,000 parts of barium. By radio-active methods, however, 1 part of radium has been detected when mixed with  $10^{13}$  parts of uranium; in other words, the radio-active test was one thousand million times more sensitive than the spectroscopic. Into the details of such tests we have not space to enter.



As regards the emission of  $\alpha$ -particles, it has been determined, by carefully counting the scintillations in a spintharoscope and by other methods, that 1 gram of radium in equilibrium emits  $1.36 \times 10^{10}$   $\alpha$ -particles per second. At the end of its detectable path, when its ionising power is exhausted, it is probable that the  $\alpha$ -particle is suddenly stopped and becomes an ordinary atom of helium.

*$\beta$ -Rays.*—These are distinguished from the  $\alpha$ -rays by their very powerful photographic and fluorescent effects, but their ionising power is relatively very small. They have great penetrative power, passing readily through several millimetres of copper, aluminium, glass, etc; but the measurement of the "absorption coefficient" is difficult because (i.) its value is very much influenced by relatively small differences in velocity, and (ii.) the true absorption is interfered with by a "scattering" effect which influences more particles than are stopped by absorption. M. and Mme. Curie early showed that the  $\beta$ -rays transport negative electricity, for an insulated metal plate becomes negatively charged when placed so that the  $\beta$ -rays fall upon it, even after the rays have penetrated a thin sheet of metal connected to earth. They are, in fact, identical with the cathode rays of Crookes, which have been already discussed with some detail (*see* page 687). Experiments subsequent to those previously referred to have shown that the velocity of the  $\beta$ -particles is not constant, but depends on the circumstances of their production, and varies over a great range, approaching sometimes, but not equalling, the velocity of light. In fact, it is now widely held that the  $\beta$ -particle is a single electron or atomic electric charge travelling free and unassociated with ponderable matter.

*$\gamma$ -Rays.*—These are distinguished from  $\alpha$ - and  $\beta$ -rays by their quite extraordinary powers of penetration. Rutherford has shown that as much as 1 per cent. of the  $\gamma$ -rays remains after absorption by passing through 7 cms. of lead or 19 cms. (over 7 inches) of iron or 150 cms. (nearly 5 feet) of water. They produce both photographic and fluorescent effects, but their ionising power is relatively feeble. They are not deflected by the most powerful electric and magnetic fields, and in this and their other properties very closely resemble X-rays. Their quantity, however, in any given Becquerel radiation is relatively unimportant as compared with the  $\alpha$ - and  $\beta$ -rays.

The investigation of the properties of the  $\gamma$ -rays is complicated by the fact that they give rise under certain conditions to what have been called "secondary  $\beta$ -particles" having the properties of ordinary  $\beta$ -particles. Some experimenters have put forth the view that the primary  $\beta$ - and  $\gamma$ -radiations are interdependent.

*Nature of the Rays.*—It has been already remarked that the researches

into the mechanism of the various kinds of Becquerel radiations have been extensive and minute and are far from being finished. The present position with regard to the *nature* of the constituents seems to be that :—

- (i.) *α-particles* are positively charged corpuscles, the corpuscles being of atomic dimensions and consisting of charged atoms of helium, the mass of each atom being  $6.8 \times 10^{-24}$  grams, and the velocity of emission about one-fifteenth the velocity of light.
- (ii.) *β-particles* are negative electrons detached from matter moving at various velocities sometimes approaching but not exceeding the velocity of light.
- (iii.) *γ-particles* are regarded either as waves of electro-magnetic character similar to light or as discrete electrically neutral particles consisting of one negative and one positive electron; but the existence of a positive electron has not hitherto been proved.

**Transmutation of the Elements.**—From the foregoing it will be gathered that in experiments on radio-activity we are dealing with the ultimate structure of atoms and with changes which may convert the atom of one element into the atom of another; in other words, the processes experimented upon may lead to a transmutation of elements of which no example exists in the whole range of chemistry. In fact, modern chemical science is built up on the fundamental hypothesis that the elements are bodies which cannot be altered, though the properties of compounds formed from them may be infinite in their variety.

But with the expulsion of *α*- and *β*-particles from radio-active substances there is distinct evidence of the simultaneous production of new types of matter. The idea has been persistently followed up with respect to the genesis of an element, helium, which is only found in minerals which are radio-active, and as the result of laborious research it is now considered as proved that helium (atomic weight = 4) is a product derived by radio-active processes from radium (atomic weight = 226.4), and may be from other radio-active elements. Helium itself is not radio-active. Its production from radium opens up a wide field for research into the physical constitution of atoms.

No other transmutation product, consisting of a well-known element, has been as yet definitely proved to exist, but some experimenters are of opinion that lead is the ultimate product of the disintegration of uranium, and some other similar cases are considered probable.

**Energy produced by Radium.**—The radio-active changes undergone by radium become still more remarkable when it was discovered that

these changes are accompanied by a production of heat in what must be regarded as large quantities. This heat energy was measured by Curie and Laborde in 1903 by enclosing a known quantity of radium in a Bunsen ice calorimeter. They found that 1 gram of radium evolved 100 calories every hour; in other words, it evolved sufficient heat in one hour to raise a quantity of water equal in mass to itself from the freezing to the boiling point. This result is truly astonishing, and gives us ideas of the intrinsic energy of the atoms which exceed anything that we could reasonably have expected.

On account of the penetrating power of the radiations, exact numerical interpretation of the results is not easy. More recent researches, however, place the evolution of energy at a higher figure. The result obtained (1908) was that 1 gram of radium (element) in equilibrium with its products as far as radium C, generates 118.0 calories per hour, with a probable uncertainty of 0.5 per cent. attaching to the amount of other products.

The continuous evolution of energy by radium is also strikingly shown by collecting the gases which are formed without intermission in aqueous solutions of radium. These gases are found to be hydrogen and oxygen in nearly the proportion in which they exist in water, the hydrogen, however, being distinctly in excess. It has been shown in other parts of this book (*see* page 151 and elsewhere) that the decomposition of water requires the supply of energy in relatively large quantity. In the case under consideration the requisite energy is supplied by the radium. This radio-active decomposition of water involves other phenomena which cannot be discussed here.

**Röntgen Rays and Becquerel Rays.**—It will be obvious from the preceding that there are many points of similarity between rays emitted by radio-active bodies and the X-rays discovered by Röntgen. In view of their great ionising power the X-rays would appear to be most nearly allied to the  $\alpha$ -rays, and again both types are distinguished by having different penetrative powers according to their methods of production. The difference in penetrative power of X-rays from "hard" and "soft" tubes has already been commented on, and there are similar differences, though apparently not nearly so wide, in  $\alpha$ -rays. For medical purposes the rays which are most easily absorbed, the "soft" rays, are most efficient, but the degree of absorption is being found to be very important in different applications, and the penetrative power may be referred to for medical purposes as the "quality" of the ray. It was noted on page 693 that Mr. Jackson had early found that platinum is one of the best materials for the anode or anti-cathode in an X-ray tube, and it was also early discovered that when an X-ray strikes a metallic surface that surface emits secondary rays. It is now known that the "quality" of the X-ray after striking the metal



surface depends entirely on the metal struck, and is constant for the same metal. Thus, iron, silver, copper, etc., each give out a perfectly definite Röntgen radiation, and it may be noted that the Röntgen radiation from silver has about the same penetrative power as that given out by radium. This discovery may have far-reaching consequences in medical applications.

**Other Phenomena.**—Another property which it has hitherto been found is possessed only by some radio-active bodies—namely thorium, radium, and actinium—is that they can impart radio-activity to surrounding objects. Thus the air in the neighbourhood of a thorium compound itself emits  $\alpha$ -rays of a kind similar to those emitted by the thorium compound. Solid bodies in the neighbourhood also become radio-active in a similar way. The effect has been shown to be due to the emanation of excessively minute quantities of matter from the originally radio-active substance. This *gaseous emanation* is peculiarly inert chemically, but that it consists, in the case of radium, of real matter is proved by its condensation at very low temperatures ( $-154^{\circ}$  C. for the radium emanation) and by quantitative experiments on its vapour pressure, boiling point, freezing point ( $-71^{\circ}$  C.), density, spectrum, etc. It has been deduced that one monatomic molecule of emanation results per atom of radium disintegrating. Actinium and thorium emanations have also been experimented upon.

Early in 1902 Elster and Geitel found that certain conductors, especially aluminium and copper, can be made radio-active without being exposed to the influence of any previously radio-active body. To show this, raise a carefully insulated wire, say about 0.02 inch in diameter and 30 feet long, to a negative potential of 3,000 or 4,000 volts, and keep it at that potential for some hours. The surface then becomes radio-active, and can affect a photographic plate or discharge an electroscope. The activity persists for several hours after the electrification is withdrawn, and the radio-active layer can be rubbed off and transferred to leather. One explanation is that during the prolonged charging multitudes of negative electrons are driven off, and that the active layer left consists of free positive ions,

More recent investigations, however, show that there is present in the atmosphere, probably due to the breaking up of uranium and thorium atoms, small quantities of radium emanation and thorium emanation which may account for the radio-active condition of the above conductors, especially as the radio-active layer can be rubbed off. Such charged bodies would attract the emanation, and in Rome and in Manchester the equilibrium quantity of active deposit on a negatively charged wire after long exposure to the atmosphere has been found to be mainly due to thorium.

Other consequences of atmospheric and natural radio-activity would lead us too far afield. Enough has been said to show how wide and important a field of research has been opened up by Becquerel's original discoveries.

## CHAPTER XIX

## ELECTRICAL MEASUREMENTS

THE important part which the science of exact measurement has played in the development of the applications of electrical laws, as well as in the elucidation of those laws, has already been briefly emphasised in the introduction (*see* page 341) to Chapter IX., and in that chapter the simplest methods of such measurements, involving the most obvious adaptations of fundamental principles and laws, have been described. The subject, however, is so important, and so liable to be passed over in the not unnatural anxiety to learn as much as possible about the fascinating applications of electrical science, that it seems desirable to devote a little further space to it, with the object of familiarising the reader with some of the metrological resources at the command of electrical workers. Moreover, the study of even a few forms of instruments will be useful in emphasising the fundamental laws which affect not only them, but also the more rapidly changing developments, some of which so quickly become obsolete and lose their interest and importance. Without any pretence at an exhaustive treatment of a very large subject, the remainder of the volume will be devoted to the further consideration of the methods of making some of the measurements which are of most importance and interest.

## I.—MEASUREMENT OF SMALL CONTINUOUS CURRENTS

In many testing operations, even those dealing with engineering problems, the accurate measurement of very small continuous currents becomes a question of great importance. Such measurements are usually made by galvanometric methods, the general principles of which have been described at pages 345 to 347; but the most sensitive instrument there referred to—Nobili's astatic galvanometer—is far from meeting the requirements of modern testing work; and therefore now there will be described as promised some of the methods by which the sensitiveness of this early instrument has been enormously increased.

**Optical Magnification of Deflections.**—The most obvious method of increasing the sensitiveness of any deflectional instrument is by the magnification of its deflections. The great majority of instruments measure by means of the rotation of a part of the instrument, more or less free to move round some fixed axis, and the accuracy of the measurement frequently depends upon the exact determination of the amount or angle of the rotation.

When the rotating parts are small, an obvious way of diminishing the error of the reading is to attach a light pointer in some convenient position, and to allow the end of the pointer to move over a graduated scale. When the length of the pointer has been increased as much as circumstances allow, additional accuracy can be obtained by using a magnifying glass or simple microscope to observe the exact position of the end of the pointer.

The accuracy of reading, especially for very small deflections, is, however, very much increased, without the inconveniences connected with a long unwieldy material pointer, by using a beam of light directed on to and reflected from a mirror properly attached to the rotating system. Such a beam can be made many feet in length by well-known optical methods, and, however long, it has no mass, and does not interfere with the movements of the rotating system.

Two methods of using such a beam are in common use. In one a plane mirror is employed, and the image of a scale placed in front of it is viewed in a telescope at a distance. In the other, the light from some suitable

source of illumination is thrown on to the mirror and the reflected beam brought to a focus, either by means of a lens or by the mirror being concave, on a suitable scale, the movements of the spot of light upon which enable the deflection to be observed.

The first method is diagrammatically depicted in Fig. 706, in which  $s$   $s$  represents, in section, a small plane mirror attached, say, to a compass needle  $N$   $S$ . If a ray of light  $Q$   $O$  falls upon this mirror, it will be reflected in the direction  $O$   $P$ ;  $m$   $m$  is a scale, say a metre divided into millimetres, and  $F$  a telescope; an eye looking through  $F$  will see one of the divisions at  $Q$  in the centre of the field of the telescope. Very slight rotations of the mirror correspond to considerable distances on the scale, and these distances become greater the further the scale and telescope are removed from the mirror.

The second method of observation is shown in connection with a galvanometer mirror in Fig 707. The rays of light from the lamp coming through the slit  $m$   $m$ , are thrown by the lens  $L$  upon the mirror  $s$  of the galvanometer, which reflects them to  $a$  upon the scale  $t$ . The image of the slot falls upon zero on the scale when the coils of the galvanometer are without current, and moves to left or right, as the needle is deflected.

A more modern form of lamp and scale, made by Messrs. Nalder Bros. and Co., is shown in Fig. 708. The box  $B$  contains an electric glow lamp, to

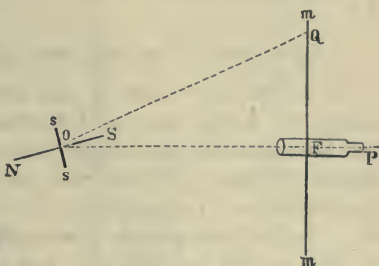

Fig. 706.—The Mirror, Telescope and Scale.



which current is passed through the terminals  $\tau \tau$ . The light emerges through the tube  $L$ , which, if the reflecting mirror be plane, contains a condensing lens. After reflection the light is received on the semi-transparent celluloid scale  $s$ , and anyone standing behind this scale will be able to see the image with-

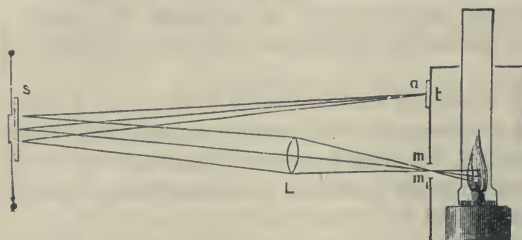

Fig. 707.—Action of the Lamp, Mirror and Scale.

out darkening the room, as is necessary when the apparatus shown in Fig. 707 is used. Horizontal and vertical adjustments bring the working zero to any convenient position, and a massive foot  $F$  gives stability to the whole apparatus.

If in the use of any of the above or similar devices it is required to deduce the actual angle of deflection of the mirror, it must not be forgotten that the reflected beam of light turns through twice the angle through which the mirror turns. To prove this, let  $s s'$  (Fig. 709) represent a mirror, and  $o n$  the normal or perpendicular to it.  $F$  is the lamp sending a beam of light in the direction  $F o$ , and  $o b$  is the reflected beam, making the angle  $b o n =$  the angle  $F o n$ . If now the mirror be moved into the position  $s_1 s'_1$ , so that the normal to it is  $o n_1$ , making with the incident beam the angle  $F o n_1$ , the reflected beam must form an equal angle with the normal, and must therefore fall in the direction  $o b_1$ , so that the angle  $b_1 o n_1 =$  the angle  $F o n_1$ . The mirror has moved through the angle  $s o s_1$ , while the reflected ray has moved through the angle  $w o w_1$ . If we compare the two angles we find that  $w o w_1$  is double the angle  $s o s_1$ . For the law of reflection shows us that : (i.) the angle  $F o b =$  twice the angle  $F o n$ ; (ii.) the angle  $F o b_1 =$  twice the angle  $F o n_1$ ; hence (iii.) by subtraction, the angle  $b o b_1 =$  twice the angle  $n o n_1$ . But the angle between the two normals equals the angle between the two positions of the mirror. Hence the angle  $b o b_1$ , or  $w o w_1 =$  twice the angle  $s o s_1$ .

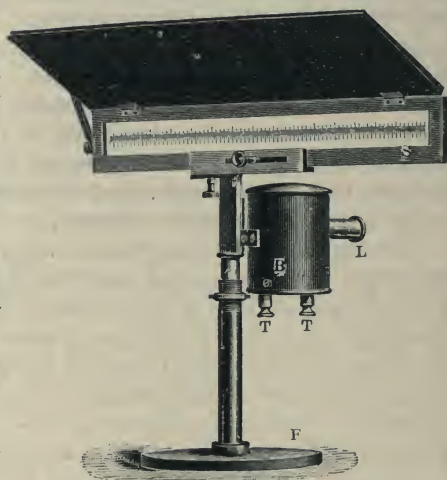

Fig. 708.—Lamp Stand, with Transparent Scale and Glow Lamp.

**Sensitive Galvanometers.**—By a “sensitive” galvanometer is usually meant a galvanometer which will measure accurately very small currents, say a micro-ampere\* or less, down to a small fraction of a micro-ampere.

The deflection of a galvanometer for a certain current depends upon the balancing of two sets of forces, under the influence of which the movable part of the instrument takes up a definite position. These forces may be conveniently referred to as the deflecting and the controlling forces, due respectively to the magnetic effect of the current and to the system of control adopted, whether magnetic or mechanical. Thus the deflection for a given current, and therefore the sensitiveness of the instrument, can

be increased either by *increasing* the deflecting or by *diminishing* the controlling forces. We have already had an example of both these methods in the “*Astatic Galvanometer*,” described on page 346. But the methods then referred to, developed and combined with the methods of optical magnification just described, have carried the sensitiveness of modern galvanometers far beyond that of Nobili’s instrument. Gauss and Weber were the first to use the method of optical magnification in the galvanoscope which formed the receiver of their electro-magnetic telegraph, described at page 390. Galvanometers on the same principle constructed by Weber and by

Wiedemann have been described in previous editions of this book. The greatest step in advance, however, was taken by Lord Kelvin, then Professor Thomson, who in the “*speaking galvanometer*,” used in the early days of cable-telegraphy, replaced Wiedemann’s heavy steel mirror by a light, delicately suspended glass mirror, to the back of which two or three strips of magnetised watch-spring steel were attached. Later he applied the astatic principle used by Nobili, each of the two parts of the astatic magnet system being placed at the centre of a coil as shown diagrammatically in Fig. 710. Here the small magnets  $n s$  and  $s' n'$  are shown attached to a light mica strip  $s$ , which is suspended by a short torsionless fibre from  $A$ . The mirror  $o$  is attached to the centre of the strip and between the upper and lower current coils. The continuous line from  $t$  to  $t'$  represents the conducting wire the direction of the current being indicated by arrow heads. It

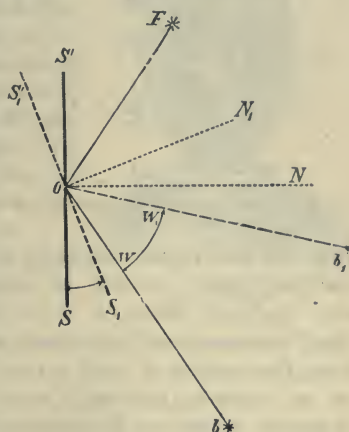

Fig. 709.—Double Angle of Reflection.

\* The prefix “micro” denotes *one-millionth* part, so that a micro-ampere is a millionth of an ampere.

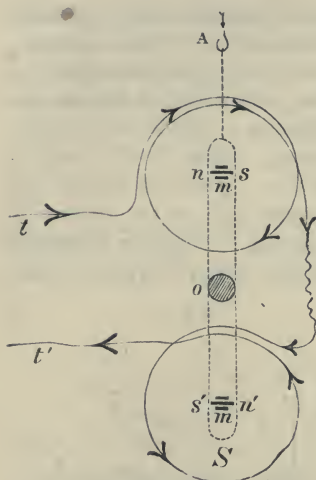

Fig. 710.—Connections of Upper and Lower Coils.

should be noticed that the upper and lower magnets have their like poles turned in opposite directions (as in Fig. 311), and that the current, which circulates in a clockwise direction round the upper magnet, circulates in a counter-clockwise direction round the lower. Accordingly, the magnetic effect of the current tends to turn both sets of magnets in the same direction, and a beam of light directed on to the mirror from the front would be deflected to the left when a suitable current passes.

A very sensitive Kelvin galvanometer constructed on the above principles is shown in Fig. 711. The increase of the deflecting forces is obtained by winding many thousands of turns on the coils, which in this case are four—namely, two (a front and a back coil and a front

coil) for the upper magnetic system and two for the lower. It will be remembered that the magnetic effect of a coil depends upon the "ampere-turns" (see page 281); if, therefore, the current is only a very small fraction of an ampere, the only way in which the magnetic effect can be increased is by having a large number of turns, which necessitates the use of very fine wire, as otherwise the coils would become unwieldy. In this instrument the wire used is of copper only 0.0014 inch in diameter, and is over 16 miles long. The controlling magnet *M* is mounted on the top of the case, which is placed over the coils when in use. This magnet can be moved up and down vertically

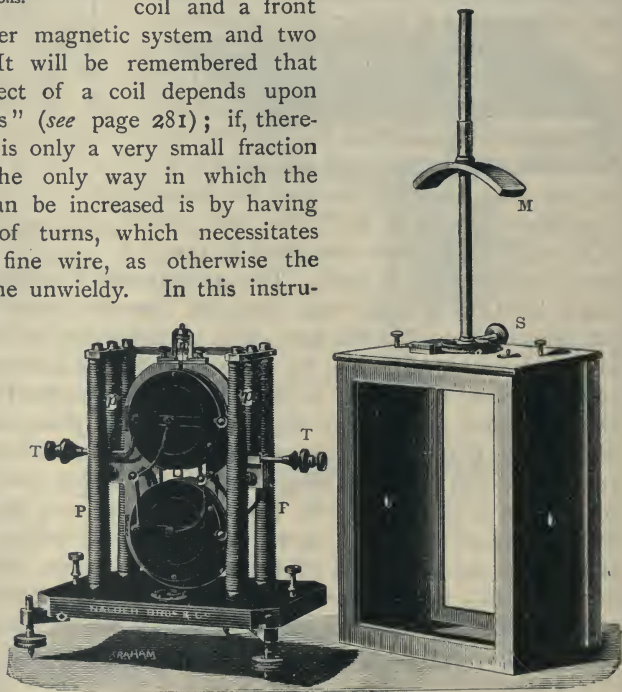

Fig. 711.—Sensitive Reflecting Galvanometer.



until it is in a position in which its tendency to rotate the upper magnets  $n s$  (Fig. 710) in one direction is nearly counterbalanced by its tendency to turn the lower magnets  $s' n'$  in the opposite direction. In this way the controlling forces may be reduced considerably, and the sensitiveness correspondingly increased. The magnet  $m$  can be rotated by the tangent screw  $s$  (Fig. 711) so as to bring the suspended needles to the zero position when no current is passing. In an instrument so sensitive as this it is very important that the insulation should be as perfect as possible. The coils are therefore mounted on the long corrugated ebonite columns  $P P$  and the terminals  $T T$  are suspended from the similar ebonite columns  $p p$ . These terminals pass through holes in the case without touching it, and the air in the case is kept dry artificially by placing some desiccating chemical inside. The instrument will detect the presence of a current of one thirty-six-thousandth part of a micro-ampere.

A much more portable instrument of this class, and one more convenient for ordinary work, is shown in Fig. 712. Here the four current coils are imbedded in the two upright oval ebonite slabs which form the body of the instrument. The front slab can be removed and the suspended system exposed for examination or repair by unscrewing the nuts  $a a'$ ,  $b b'$ . On replacing the slab the necessary connections between the back and the front coils are made by screwing down the clamping nuts. The terminals are  $T T'$ . The controlling arrangements are a little more complicated than in the last instrument. They consist of a small permanent magnet  $n s$  fixed below the coils and a pair of "scissors" magnets  $N S$  above. The latter are shown separately in Fig. 713. By



Fig. 712.—Simple Reflecting Galvanometer.

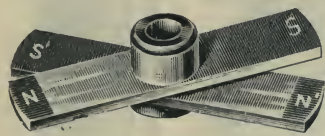

Fig. 713.—Scissors Controlling Magnets.

altering the angle between the two "scissors" magnets from direct opposition (*i.e.*  $N$  over  $s'$ ) to direct coincidence ( $N$  over  $N'$ ) a wide range can be obtained in the value of the controlling field set up.

In the galvanometers above described the current-carrying coils are fixed, and the magnetic system on which they act is movable. Since, however, it is a case of relative motion, it is obvious that the coils might be made movable, and the magnetic system fixed. This would make it possible to use a magnetic system much stronger than the magnetised watch springs in the Kelvin Galvanometer. On the other hand, if the coils are to be movable they must be made much lighter,

and there is a further complication in the necessity for passing the current into and out of the movable coils without interfering with their freedom of movement.

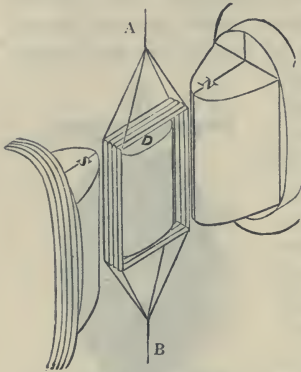

Fig. 714.—Maxwell's Suspended Coil Galvanometer.

The inherent difficulties have been overcome in the widely used, so-called D'Arsonval moving-coil galvanometers, in which a coil is suspended between the poles of a strong permanent magnet. The instruments are named after M. D'Arsonval, a French electrician who devoted much time and thought to their development and improvement. The idea, however, was put forward much earlier by Clerk Maxwell in his classical work on "Electricity and Magnetism," from which Fig. 714 is copied. The coil is suspended as shown between the poles, N S, of a powerful magnet, either a permanent or an electro-magnet, but in practice usually the former. To concentrate the field in the space occupied by the wires of the coil a piece, *d*, of soft iron is usually fixed rigidly in the open space inside the coil and between the poles of the magnet N S. The coil is suspended between the two stretched metal wires A and B, through which the current is brought into and led away from the coil, and which also furnish a mechanical controlling force due to torsion, which is brought into play when the coil rotates. The method shown was also employed by Lord Kelvin in his syphon recorder, which has been widely used in cable telegraphy.

D'Arsonval galvanometers have assumed many shapes under the hands of numerous inventors and designers. One of the early forms devised by M. D'Arsonval himself is shown in Fig. 715. In this instrument M M is an inverted horseshoe permanent magnet, and A a cylinder of soft iron placed between its poles, leaving two narrow gaps in which the suspended coil *c c* can swing. A small mirror *m* for observing the deflection is mounted immediately over the coil, which is suspended between the two stretched wires *a* and *b*. The lower end of the wire *b* is

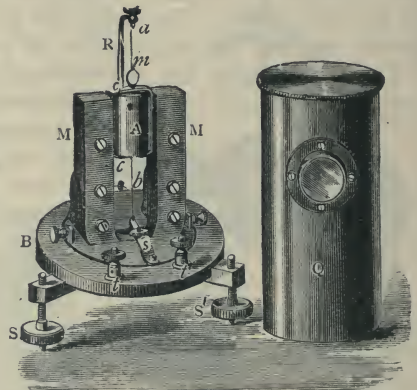

Fig. 715.—D'Arsonval's (Maxwell) Galvanometer.

attached to the free end of a flat spring, which can be set up by the screw *s* so as to keep the wires taut. The terminals *t*, *t'* are placed outside the cover *Q*, one of them being electrically connected to the upper suspension *a* through the rod *R*, and the other to the lower suspension *b* through the flexible spring; the ends of the coil *c c* are electrically connected to *a* and *b* respectively. When a current passes through the coil the latter tends to turn so as to bring the field set up by the current into coincidence with the field of the permanent magnet, for in the zero position of the coil these two fields are at right angles. As soon, however, as the coil moves from the zero position the wires *a* and *b* become twisted, and a controlling torque is set up, which increases with the deflection, and eventually brings the coil to rest. The deflection increases with the current, but is not necessarily proportional to it, although the torsional forces are proportional to the deflection.

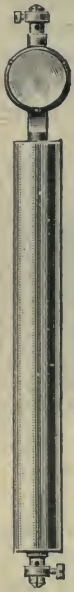

Fig. 717.—  
Mounting  
of Coil.

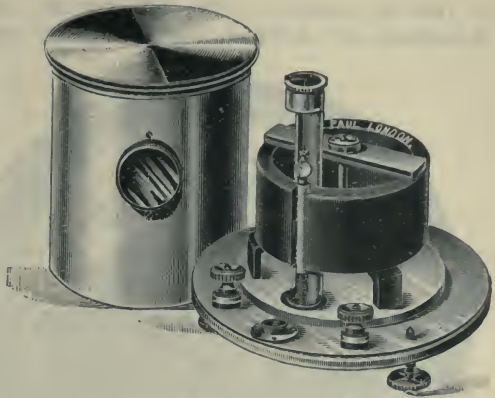

Fig. 716.—Ayrton-Mather Moving-coil Galvanometer.

Fig. 716 depicts a form of D'Arsonval galvanometer of a type devised by Professor Ayrton and Professor Mather at the Central Technical College in London. In instruments of this type the poles of the permanent magnet (which is cylindrical in Fig. 716) are brought very close together, and the soft iron core inside the coil is dispensed with. The coil itself forms a long, narrow rectangle, wound upon a metal or an ivory frame, and surrounded, as shown in Fig. 717, by a metal tube in which damping eddy currents are set up whenever the coil is rotating in the field. This figure also shows details of the clips for the leading-in wires and of the mounting of the mirror. In Fig. 716 this coil is mounted in a cylindrical brass tube, the greater part of which has been cut away; it hangs from the top suspension, the bottom connection being made through a light coiled spiral spring. The suspension tube and coil can be readily removed and replaced by another tube and coil, the latter having a greater or less number of turns, thus altering the sensitiveness of the instrument.

Many other patterns of moving-coil galvanometers are in use, and some of them give a readable deflection with currents less than a thousandth of a micro-ampere.



As an example of the pivoted and portable type of moving coil galvanometer, to which we shall have to refer more fully later on,

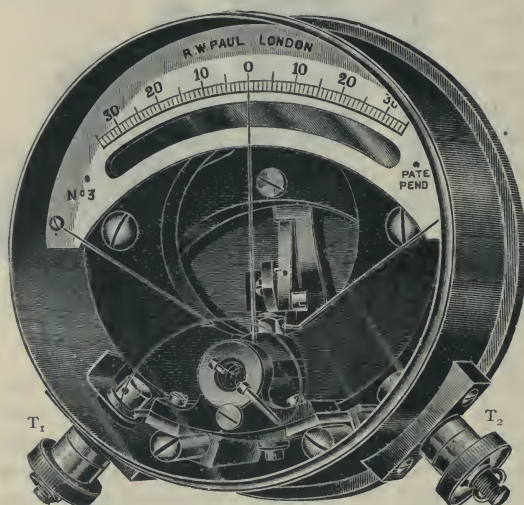

Fig. 718.—Paul's Moving-coil Galvanometer with Single Pivot.

This armature is spherical instead of being cylindrical, and consists of two hemispheres bolted together by a pin. A vertical hole is bored

half way through the sphere, and the pivot to carry the jewelled bearing is placed at the bottom of this hole on the pin. The coil (Fig. 720) is circular instead of being rectangular, and is attached to the vertical spindle. The pointer (Fig. 719) is attached to the coil at the top, and is

balanced by the usual counter weight. The control is by a cylindrical spiral spring, which can be seen in Figs. 718 and 720, and the current is passed into the coil from the terminal  $T_1$  through this spring. The connection of the coil to the terminal  $T_2$  is through a flexible strip at the lower end. It will be noticed that the mounting of the coil is such

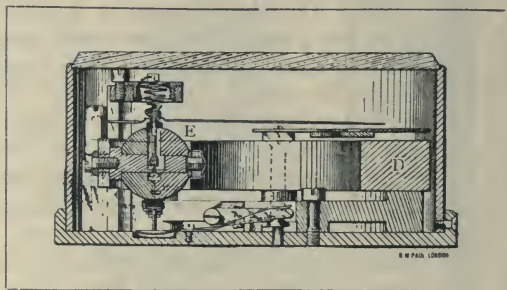

Fig. 719.—Section of Paul's Moving-coil Galvanometer.

Fig. 718 shows a pattern designed by Mr. R. W. Paul. In this modification an attempt is made to minimise the disadvantage of all pivoted instruments, namely, the friction on the pivots, by using only one pivot, which is placed at the centre of the soft iron armature (A, Fig. 715). The arrangement is shown more clearly in Figs. 719 and 720, the first of which is a median vertical section, and the second a perspective view of the working part, with half of the armature (Fig. 719) removed.

that the instrument can be tilted somewhat without interfering with the readings. During transit the movable system is lifted off its pivot by the spring  $y$ , which is raised by lowering the plunger  $u$ , thus allowing the lever arm  $w$  to be pressed down by a spring,  $v$ . The air-gaps between the poles of the permanent magnet  $D$  and the sphere  $E$  are narrow, and carry a strong and uniform field within the limits of the deflection of the coil, which is  $35^\circ$  on either side of the central zero. The deflections are therefore proportional to the currents, and with a coil having a resistance of about 200 ohms, one micro-ampere gives a deflection of one degree. The instrument is thus quite sufficiently sensitive for a large range of tests, and is, like all these moving coil permanent magnet instruments, very little affected by ordinary external magnetic fields.

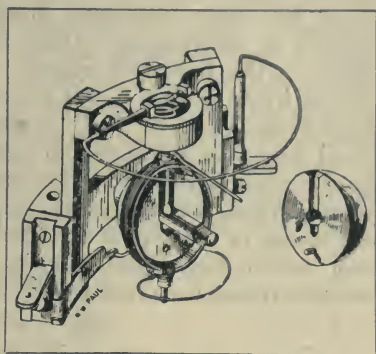

Fig. 720.—Circular coil and other details of Fig. 718.

**Dead-Beat Galvanometers.**—For rapid working, whether with sensitive or other galvanometers, it is a great advantage to have a *dead-beat* instrument, in other words, an instrument the movable parts of which will quickly come to rest when a current is passed through or suppressed, instead of oscillating about the position of rest for a longer or shorter period. In many sensitive galvanometers, therefore, some kind of fluid or magnetic friction is introduced, which more or less quickly brings the moving part to rest without influencing the final reading. Lord Kelvin in his early galvanometers enclosed the suspended mirror and magnets in a “dead-beat chamber,” that is, in a closed space in which they had barely room to move with very little clearance. The friction of the disc of the mirror against the confined air in the chamber quickly brought the former to rest without affecting its final position. A needle or other device whose motions are restrained in this way is technically said to be “damped.”

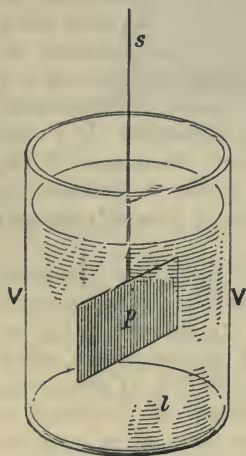

Fig. 721.—Liquid Damping.

Another method of “damping” uses liquid friction as shown diagrammatically in Fig. 721. The axis of the suspended system is prolonged by a stiff wire  $s$ , which, at its lower end, carries a thin plate  $p$ , usually of platinum, dipping into a viscous liquid, such as glycerine or non-volatile

oil, contained in a vessel  $v v$  attached to the frame of the instrument. When the suspended system rotates  $p$  moves in the viscous liquid, and so the oscillations are "damped" and soon die away.

A still more interesting principle is that of *magnetic damping*, one method of carrying out which is shown in Fig. 722. The magnet  $M$ , which is the suspended magnet of a galvanometer, hangs in a hole in the centre of a mass  $K$  of solid copper. The magnet is for convenience what is known as a "bell" magnet, the shape of which will be understood from the elevation and section shown on a somewhat larger scale at the side.  $s$  represents the reflecting mirror which is rigidly attached to  $M$ . When the magnet  $M$  rotates inside the copper mass  $K$  currents are set up in the copper according to the laws of magneto-electric induction which have been fully explained. The magnetic effect of these currents is such as to tend to stop the motion of the magnet which produces them, and the latter is rapidly brought to rest.

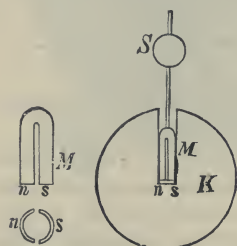

Fig. 722.—Magnetic Damping.

A moving coil or D'Arsonval galvanometer is similarly damped by magnetic friction if the coil be at the moment part of a closed circuit, as, for instance, when it is shunted or when it is short circuited. The movement of the coil in the strong magnetic field sets up E. M. F.'s in the coil, which, under the conditions named, give rise to corresponding currents whose magnetic effect tends to stop the motion. These currents are superposed on any other currents in the coil, and die away when the motion ceases; they therefore

have no influence upon the magnitude of the final deflection. It is this dead-beat action which constitutes one of the chief advantages of the moving-coil type of galvanometer. The dead-beat action is increased by winding the moving-coil on a copper or conducting frame in which currents can also be induced.

**Ballistic Galvanometers.**—Before leaving the subject of sensitive galvanometers a little space may be devoted to the "ballistic" galvanometers, whose function, as already explained (*see* page 344), is to measure quantities of electricity rather than steady currents. Such galvanometers differ fundamentally from "dead-beat" galvanometers, inasmuch as everything which may retard the motion of the suspended system is eliminated as far as possible. This is necessary, because the quantity to be observed is not a steady deflection, but the magnitude of the *first* swing of the suspended system due to an impulse given to it whilst at rest. Anything, therefore, which tends to retard the movement or the needle will diminish the magnitude of the first swing, and thus lead to an under-estimate of the impulse and its physical cause—namely, the quantity of electricity discharged through the galvanometer.



A galvanometer specially designed to fulfil these conditions is shown in Fig. 723. There are two coils only, hinged together so that the front one may be turned to one side as shown to enable the suspended magnets to be got at. These coils are in ebonite boxes, and all solid pieces of metal in which damping currents might be set up are dispensed with as much as possible. The suspended magnets are all of the bell type, already described (Fig. 722), because this type gives rise on rotation to very little air friction. There are four such magnets; the two in the centre with similar poles facing one another, and one at the top and the other at the bottom of the coil, with their poles in the reverse direction to those of the centre magnets, thus forming an astatic system. All four magnets

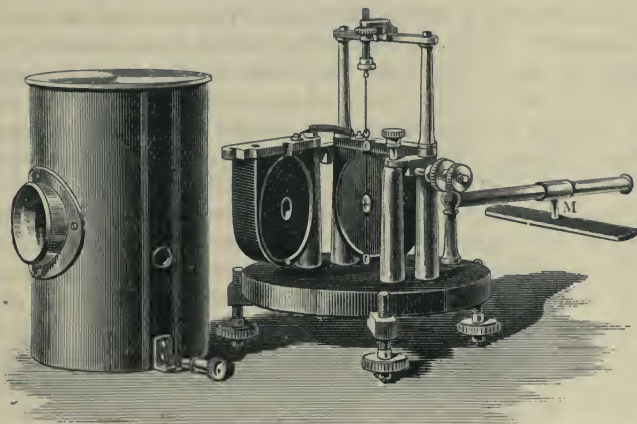

Fig. 723.—Nalder's Ballistic Galvanometer.

are carried on a stiff wire, which also carries, just above the top magnet, a mirror, which is made as small as possible so that its rotation may not damp the motion. The suspending fibre is short, and the controlling magnet *m* is placed behind the instrument and on a level with the centre of the astatic magnets. Great care is taken to insulate the coils and the terminals, for in "ballistic" working the risk of leakage is great, owing to the electric pressures being impulsive and momentarily high.

*Ballistic Working.*—When using such a galvanometer, it can be shown mathematically that when certain conditions are fulfilled the sine of half the angle of the first swing of the needle from rest is proportional to the quantity of electricity discharged through the instrument. In other words, that—

$$Q = k \text{ Sin. } \frac{\theta}{2}$$

where  $Q$  is the quantity discharged,  $\theta$  is the angular limit of the first swing from the zero position, and  $k$  a constant depending upon the details of construction of the particular instrument. The principal conditions referred to are—

- (i.) That the suspended system shall be absolutely at rest before the passing of the current.
- (ii.) That the whole of the impulse shall be delivered before the suspended system has appreciably moved from its zero position ;  
and
- (iii.) That there shall be no damping.

The fulfilment of the first condition (i.) is usually a matter of manipulative skill in ensuring the quiescence of the needle or suspended system before a measurement is taken. The second requires that the time occupied by the discharge shall be very brief indeed when compared with the free period of swing. To fulfil this condition the suspended system, as compared with the systems used in sensitive galvanometers for steady currents, is made heavy and massive, so that its inertia may lengthen the time of free vibration, which is still further lengthened by weakening the controlling force. By careful working, the period of swing in a good ballistic galvanometer can be brought up to 20 seconds or more ; and as the discharges usually measured occupy but a small fraction of a second, condition (ii.) is fulfilled. Some of the methods of approximately satisfying condition (iii.) have been referred to in the above description of Nalder's ballistic galvanometer. As, however, it is impossible to construct a galvanometer with absolutely no damping, a correction in very exact working must be applied, calculated from what is known mathematically as the "logarithmic decrement," the details of which are beyond the scope of this book.

To "calibrate" a ballistic galvanometer for a particular experiment, the readiest method is to discharge through it a known quantity of electricity obtained by charging a condenser of known capacity (*see* page 120) with a standard cell (*see* page 364) of known voltage. From the fundamental equation of the condenser we have—

$$Q = K V$$

where  $Q$  is the quantity,  $K$  the capacity, and  $V$  the voltage between the plates ; or in words—

Quantity in **micro-coulombs** = capacity in **micro-farads**  $\times$   
pressure in **volts**.

If the deflection produced by the discharge of a known quantity in micro-coulombs so obtained be observed, the number of micro-coulombs corresponding to any other deflection will be known, provided the controlling force is always proportional to the deflection from the zero position, and that the above conditions are fulfilled.

**Shunting Galvanometers.**—The circumstances under which it becomes necessary to use a *shunt* on a galvanometer, and the elementary principles underlying the use of shunts, have already been explained (see page 352). The necessity arises more frequently when using sensitive galvanometers than with the less sensitive instruments, though the method is applicable to any galvanometer. For the former, however, it is customary to wind special coils and place them in resistance boxes, which (except as mentioned below) should always accompany the galvanometer for which they are wound. The reason for this is that the effect of a shunt of a certain resistance depends on the resistance of the galvanometer with which it is used. For we have shown (page 352) that if the resistance of a shunt be  $\left(\frac{1}{n}\right)$  of the resistance of the galvanometer, the total current in the main circuit is  $(n + 1)$  times the current measured by the galvanometer. This number  $(n + 1)$  is known as the *multiplying power of the shunt*.

**Shunt Boxes.**—In constructing such resistance boxes the fact that the resistance of metals varies with the temperature, and that different metals have different temperature coefficients must always be borne in mind. A little reflection will show that this renders it necessary that the wire used in the shunt box should be of the same material as the wire with which the galvanometer is wound. Otherwise the multiplying power of the shunt will depend upon the temperature at which the galvanometer and shunt box are at the moment of measurement, assuming that they are both at the same temperature. In other words, the *ratio*  $\left(\frac{1}{n}\right)$

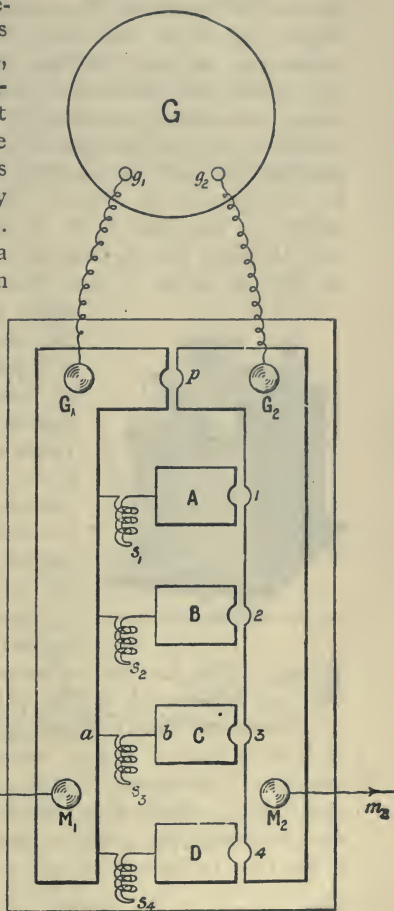

Fig. 724.—Connections of an ordinary Shunt Box.

of the resistances of the two would change with the temperature, since these resistances would vary at different rates if the materials were different.



It is convenient to arrange the connections of a shunt box somewhat differently from those of an ordinary resistance box. Fig. 724 shows diagrammatically a very common arrangement. The wires  $m_1$  and  $m_2$  are the wires of the main circuit, and are brought to the binding screws  $M_1$ ,  $M_2$  of the box, the galvanometer terminals  $g_1$ ,  $g_2$  being connected to the binding screws  $G_1$ ,  $G_2$ . The shunt coils,  $s_1$ ,  $s_2$ ,  $s_3$ ,  $s_4$ , each have one end attached to the left-hand brass strip  $G_1$ ,  $M_1$ , the other ends being attached to the blocks A, B, C, and D respectively. When a plug is inserted into any one of the holes 1, 2, 3, or 4 the galvanometer will be shunted by the corresponding coil. For instance, if the plug is in hole 3 the current entering at  $M_1$  divides at the point  $a$ ; one part flows through  $a$ ,  $G_1$ ,  $g_1$ , the galvanometer  $G_1$ ,  $g_2$ ,  $G_2$  and through the right-hand strip to  $M_2$ ; the other part flows through  $a$ , the coil  $s_3$  to  $b$ , the block c and the plug re-uniting with the other part in the right-hand strip. Since only one shunt is wanted at a time only one plug is supplied. The shunt coils  $s_1$ , etc., are usually so wound that the *multiplying power* is some power of 10, say, in the box illustrated, 10, 100, 1,000, 10,000. If the plug be inserted in the hole  $\phi$  the current passes without going through the galvanometer at all, and the latter is said to be *short-circuited*. In using sensitive galvanometers the plug should always be left in  $\phi$  when the galvanometer is not in use, thus protecting the galvanometer from the effects of any stray current which may be passing along the wires

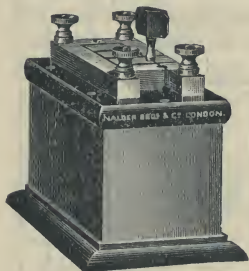

Fig. 725.—Ordinary Shunt Box.

$m_1$ ,  $m_2$ . The external appearance of a box similar to the diagram of Fig. 724 is depicted in Fig. 725.

**Universal Shunt Boxes.**—The condition that each galvanometer has to have a box of shunts wound specially for it is both expensive and irksome in practice. It has been ingeniously met by Professor Ayrton and Professor Mather in their so-called "universal" shunt. To understand their method we must revert to fundamental principles. If  $g$  and  $s$  be the resistances of galvanometer and shunt respectively, and the latter be  $\frac{1}{n}$ th of the former, we have

$$s = \frac{g}{n}$$

or

$$n = \frac{g}{s},$$

whence the multiplying power

$$n + 1 = \frac{g + s}{s}.$$

The universal shunt box is so designed that the numerator of this fraction ( $g + s$ ) is kept *constant*, in which case the multiplying power will *vary inversely* as the denominator  $s$ .

The necessary connections are shown diagrammatically in Fig. 726, in which, as far as possible, the same reference letters have been used as in Fig. 724, the main current coming along the main  $m_1$  and being led off by the main  $m_2$ . If now the plug be inserted in hole No. 3, the incoming current divides at  $G_1$  and the galvanometer section passes through the galvanometer  $G$  to  $G_2$  and then through the coils  $s_c$  and  $s_d$ ; the shunt section passes through the coils  $s_a$  and  $s_b$  and the two sections

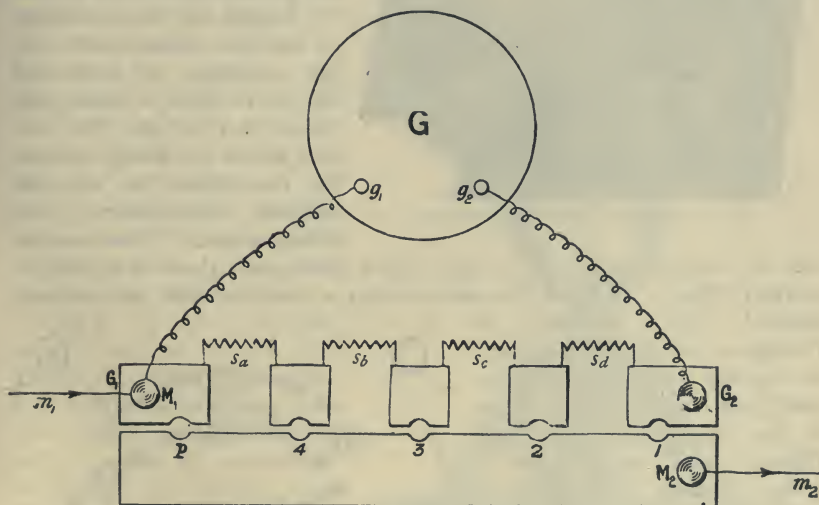

Fig. 726.—Connections of a Universal Shunt Box.

re-unite at the plug in No. 3 and pass together to the exit terminal  $M_2$ . The resistance of the galvanometer branch is therefore ( $g + s_c + s_d$ ) and that of the shunt branch is ( $s_a + s_b$ ), hence the multiplying power is

$$n + 1 = \frac{g + s_a + s_b + s_c + s_d}{s_a + s_b}$$

A moment's inspection of the figure will show that in whichever hole the plug be placed the numerator of this fraction is not changed, and the denominator consists of the coils on the left-hand side of the plug. The multiplying power is least—that is, the arrangement is most sensitive—when the plug is in hole No. 1, but the galvanometer is shunted even then, though the resistance of the shunt may be so large that the sensitiveness of the galvanometer is not much diminished thereby. The multiplying

power in this position being denoted by unity, the relative resistances of the coils  $s_a$ ,  $s_b$ ,  $s_c$ , and  $s_d$  may be so arranged as to give convenient integral multiplying powers when the plug is in either of the holes 2, 3, or 4; when the plug is in the hole  $p$  the galvanometer is practically out of circuit, and this, therefore, is, as before, the position in which the plug should be left when the galvanometer is not in use.

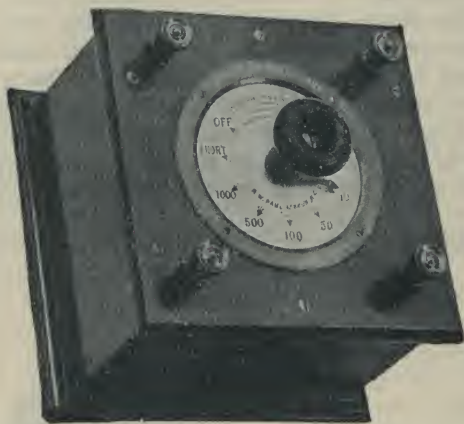

Fig. 727.—Universal Shunt Box, dial pattern.

are the multiplying powers of the various shunts, and there is a position, marked "Short," in which the galvanometer is short-circuited, and another, marked "Off," in which all through connections are broken. A diagram of the connections specifying the values in ohms of the various coils for a total resistance of 10,000 ohms is given in Fig. 728, which is worth careful study;  $G_1$ ,  $G_2$  are the galvanometer terminals and  $T_1$ ,  $T_2$  the circuit terminals.

One other point only need be mentioned here regarding the shunting of galvanometers. When a galvanometer is shunted in the ordinary way a new path is provided for the current between its terminals, and the resistance between these terminals is, therefore, diminished; in fact, this resistance varies inversely as the multiplying power, and with large multiplying powers, therefore, becomes very small. This change may, and usually will, affect the value of the main current unless a compensating resistance is intro-

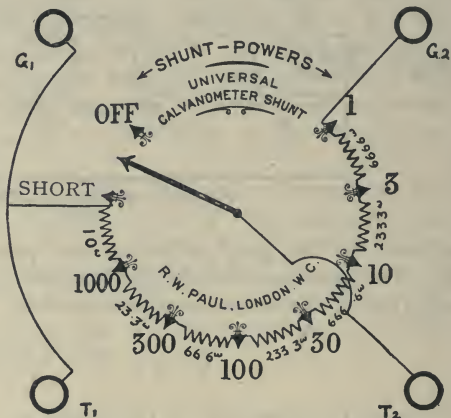

Fig. 728.—Connections and Resistances (total resistance 10,000 ohms).

duced; in fact, this resistance varies inversely as the multiplying power, and with large multiplying powers, therefore, becomes very small. This change may, and usually will, affect the value of the main current unless a compensating resistance is intro-



duced into the main circuit. Shunt boxes can be arranged to do this and thus keep the current constant. They are known as *constant-current* shunt boxes, but a description of them would lead us farther than the space available allows.

## II.—STANDARD CURRENT MEASURERS.

**Standard Galvanometers.**—These may be divided into two classes (i.), those galvanometers in which the magnitude of the current, which will give a certain deflection, can be calculated when the details of the construction are known; and (ii.) those in which, although this calculation cannot be made, a certain current always gives the same indication; in other words, those galvanometers in which the meaning of the deflections does not change from time to time.

None of the galvanometers described so far fulfil either of these conditions. As regards the first condition, modern mathematics has not yet solved the problem of calculating the current from the details of construction of these instruments and the observed deflection; and the second condition is not rigorously fulfilled by any of them.

The magnitude of the magnetic effect of a current at any point in its neighbourhood depends directly on the length of the conductor carrying the current, and is inversely as the square of the distance of the conductor from the point considered. If this distance be small then an error in measuring it will have a great effect upon the correctness of the result. Therefore, in all instruments in which the magnitude of the current is to be calculated from the observed deflection and the details of construction, the dimensions of the current carrying coil must be large. This rule is observed in the *tangent galvanometer*,

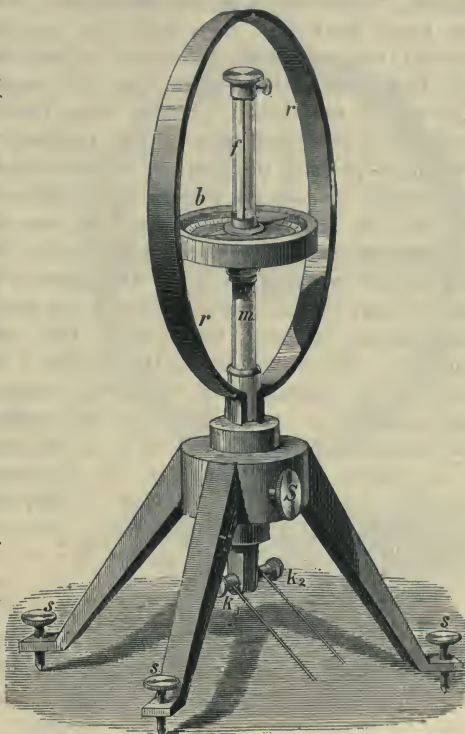

Fig. 729.—The Tangent Galvanometer.

shown in Fig. 729, The copper ring  $r$ , terminating in the binding screws  $\kappa_1$ ,  $\kappa_2$ , is placed on a wooden frame, as represented in the figure. On the metal pillar, insulated from the ring, is the box  $b$  and the magnetic needle, which is suspended by means of a cocoon thread in the tube  $f$ . The box  $b$  has a graduated circle, the centre of which coincides with the centre of the copper ring. The graduation of the scale is so arranged that the zero point lies in the plane of the ring.\* Before using the instrument, then, we must adjust it; that is, we must turn the ring until the needle points to zero. When we connect the wires of the source of electricity with  $\kappa_1$ ,  $\kappa_2$ , the current will flow round the copper ring, and cause the needle to be deflected. The earth's magnetism tends to bring the needle back again to its former position of rest, but after a few oscillations the needle at last remains stationary at the position in which the effects of the current and of the earth's magnetism balance each other. The deflection of the needle will be the greater the greater the current, and for equal currents the needle will show the same deflection. When the needle is small, so that it moves within a space throughout which the "field" due to the current may be considered uniform, the strength of the current is directly proportional to that function of the angle of deflection called the tangent. When we know the angle, a book of trigonometrical tables has to be consulted to find the tangent. Currents proportional to the numbers 1, 2, 3, etc., produce deflections whose *tangents* are as the numbers 1, 2, 3, etc. If  $c$  be the strength of current in amperes,  $r$  the radius of the ring,  $H$  the horizontal component of the earth's magnetic force, and  $\delta$  the angle of deviation, then

$$c = \frac{10r}{2\pi} H \tan \delta$$

$$\text{or } c = a \tan \delta$$

where  $a$  is a constant depending on the size of the ring and the earth's magnetic force, and having the value

$$a = \frac{10r H}{2\pi}$$

If, instead of a single band of copper, as shown in Fig. 729, a coil of several turns of about the same radius be used, the value of  $a$  becomes—

$$a = \frac{10r H}{2\pi n}$$

\* In many instruments the needle is a small, lozenge-shaped piece of steel, and to indicate the angle of deflection a long light pointer of glass, or other material, is fixed at right angles to it. Then the zero point is  $90^\circ$  from the plane of the ring, for it is not the needle but the pointer that indicates the deflection.

where  $n$  is the number of turns and  $r$  is the *mean* radius. The constant 10 is introduced into the numerators of the above equations because if it were omitted the value of the current would be given in absolute electro-magnetic units of current, each one of which is equal to 10 amperes.

The magnetometer box, shown in Fig. 729, for measuring the field set up by the current, can be replaced by one in which advantage is taken of the methods of optical magnification described above. Such an instrument is shown in Fig. 730, which represents a more modern form of standard tangent galvanometer. The box  $M$  contains a suspended mirror, with little magnets made of fine watch-spring steel attached to the back; the deflection of the mirror is observed in one of the usual ways already described. In this particular instrument there are two current circuits. One consists of a single band,  $rr$ , of copper, as in Fig. 729; the ends of this band are brought to the terminal screws  $B$ . The other consists of numerous turns of finer wire wound in a groove in the larger ring  $RR$ , the ends being brought to the binding screws  $a$ . The turns of wire in this ring have a mean radius of 25 centimetres.

In both instruments there are levelling screws to bring the plane of the coil into the vertical plane; and there are also means of rotating the coils round a vertical axis so as to bring the index accurately to zero.

Instead of the scale being divided into degrees, the divisions can very readily be made proportional to the tangents of the deflections, as in the lower half of Fig. 731, and then the *relative* values of the various currents can be read off at once in terms of the numbers marked on the scale.

Attention should be drawn to the fact that in order to determine the absolute value of the current by means of a tangent galvanometer used as a standard instrument it is necessary to measure the value of  $H$ , the horizontal component of the earth's field at the centre of the coil. A method of making this measurement has been described at page 47, but the determination is a troublesome one, and cannot be

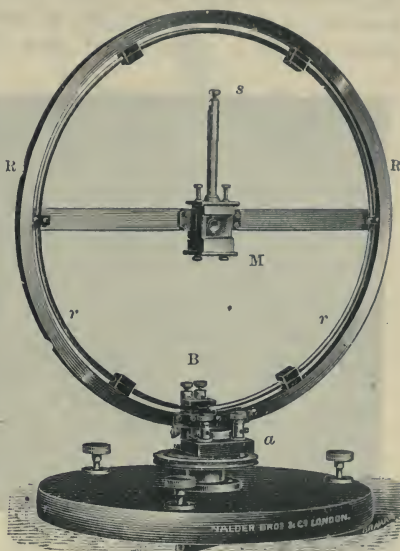

Fig. 730.—Standard Tangent Galvanometer.



rapidly made. It is, therefore, only made when the importance of the experiment warrants this expenditure of time and labour. More commonly the tangent galvanometer is used for general laboratory work as an *instrument of known law*, for if the controlling field  $H$  be kept constant the equations given above show that the current is proportional to  $\tan \delta$ , and the value of the constant  $a$  can be found by experiment.

The **electro-dynamometer**, as originally constructed by Weber, is another standard instrument, from the indications of which the value of the current passing through the coils can be calculated. In this form, however, it is seldom used, but as modified by Siemens (*see* Fig. 732) it has given rise to a widely used type of standard instrument of the second

kind mentioned above, namely, that in which, when the value of the current, which will give a certain reading, has been once accurately determined, the value of the current giving any subsequent reading is known, such value not being liable to change if reasonable care be taken of the instrument.

Weber's instrument consisted in its essential parts of two wire coils, of which one was fixed and the other hung from two conducting wires very near together so as to furnish a directing couple. The latter coil carried a small mirror, and for the exact deter-



Fig. 731.—Scale for a Tangent Galvanometer.

mination of the deviation of the movable coils readings were taken by reflection. The two wire coils tend, when currents flow through them, to place themselves parallel to each other, in the position in which the two magnetic fields would reinforce one another. This construction of a measuring instrument has two advantages, which are especially of importance in practice. First, when one and the same current flows through both coils they experience a deflecting couple proportional to the square of the current. Secondly, when through the two coils a current of definite strength and direction flows, the movable coil will turn through a definite angle,  $\theta$ , and assume a distinct position. If now the current flowing through the two coils be reversed, the movable coil will retain its deviation, the latter being only a function of the strength of the current, but not of its direction, since the fields of both coils will be reversed simultaneously. In practice for the measurement of currents which are continually reversing

the electro-dynamometer is a most useful instrument. There are two quantities equal to one another when the coil has found the position of rest: (i.) the controlling couple, depending on the mode of suspension and proportional to the angle of deviation, and (ii.) the deflecting couple, depending on the strength of the current  $C$  and the cosine of the angle of deviation  $\theta$ . Hence,  $C^2 \cos \theta = a\theta$  where  $a$  is a constant depending on the geometry of the coils. In this equation it is assumed that in the zero position the axes of the coils are at right angles to one another.

Siemens' modification of Weber's electro-dynamometer (Fig. 732) consists of a suspended movable coil  $w w$  placed at right angles to a fixed coil  $A A$ . The movable coil  $w w$  has only one turn of thick wire, whilst the fixed coil  $A A$  consists of wires having a number of turns. The ends of the movable coil dip into mercury cups into which the current is directed;  $F$  is a cylindric spiral spring which holds the movable coil in position, the weight of the movable coil being carried by a silk thread which passes up through the centre of the spiral spring and is attached at the top to a cross wire which can be turned by the small disc  $a$ ;  $z$  is an indicator attached to the movable coil, and moving over  $\tau$ , a graduated scale. The wire ends of the fixed coil are so connected with the binding screws  $1, 2,$  and  $3,$  and the mercury cups, that the current may be sent either through a few turns of the fixed coil and the movable coil, or through many turns of the fixed

coil and the movable coil, thus adapting the instrument to currents of different magnitudes. As the movable coil has only one turn, the earth's magnetism will have very little influence upon its position, and this influence can be eliminated by setting up the instrument with due regard to the direction of the earth's field. The deviation of the movable circuit is counteracted by the torsion of the spring, which can be applied by means of the knob at the top. The angle through which the top of the spring has to be moved is indicated by the pointer  $p$ , and is the measure of the *square*

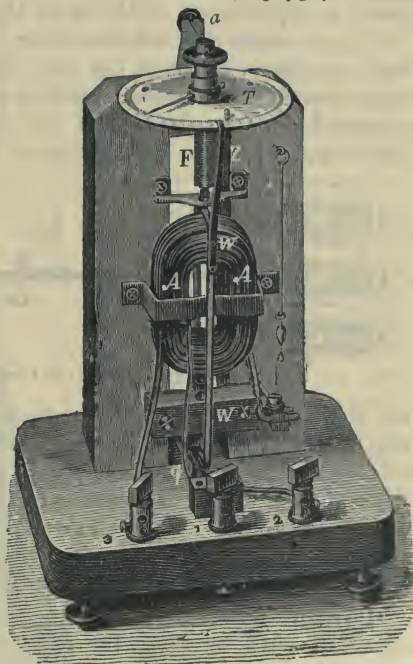

Fig. 732.—Siemens' Electro-Dynamometer.

of the strength of the current. For the vertical currents in the movable coil, being at right angles to the field of the fixed coil, will be dragged across that field with a force proportional to the product of the current and the strength of the field, and therefore proportional to the product of the currents in the two coils, since, as there is no iron present, the field strength will be proportional to the current producing it. But these two currents are one and the same current, since the coils are in series. Therefore, finally the turning force, acting on the movable coil, is proportional to the square of the current, and this force is balanced by the torsion of the spring, which is proportional to the angle through which the pointer is moved.

The *Siemens electro-dynamometer* is calibrated by placing it in series with a copper voltmeter (see page 343) and maintaining a steady current in the circuit for a measured period of time. From the amount of copper separated out, the strength of the current can be calculated in amperes. The angular position of the pointer being proportional to the square of

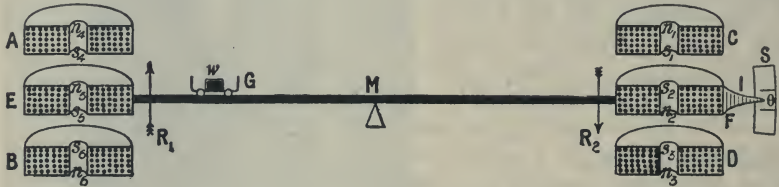

Fig. 733.—Principle of Lord Kelvin's Current Balances.

the strength of the current, the square root of the dynamometer's indication will vary as the strength of the current, and the proportion of this reading to the strengths of current obtained by the voltmeter will give the reduction factor, or constant of the instrument—that is, the multiplier which will enable us to reduce the indications of the dynamometer to amperes. This number is called the constant of the apparatus, because, once determined, all calculations may be easily effected by means of it.

**Current Balances.**—The last type of *standard* current measurers to which we shall refer are the *current balances* of Lord Kelvin. In these the mechanical attractions and repulsions between a movable and a fixed part or parts of the circuit are counterbalanced by a known weight sliding along the beam of a balance to which the movable part of the circuit is attached. The principle is shown diagrammatically in Fig. 733, in which six coils, A, B, C, D, E, and F, are shown in section. These coils are all electrically in series with one another in the circuit, but the first four, A, B, C, and D, are fixed, and the other two, E and F, are attached to the beam of a balance which rests on a knife edge at M. On each side there are two fixed coils with a movable coil between them, all co-axial, the two movable coils on the arms of the balance being accurately balanced so



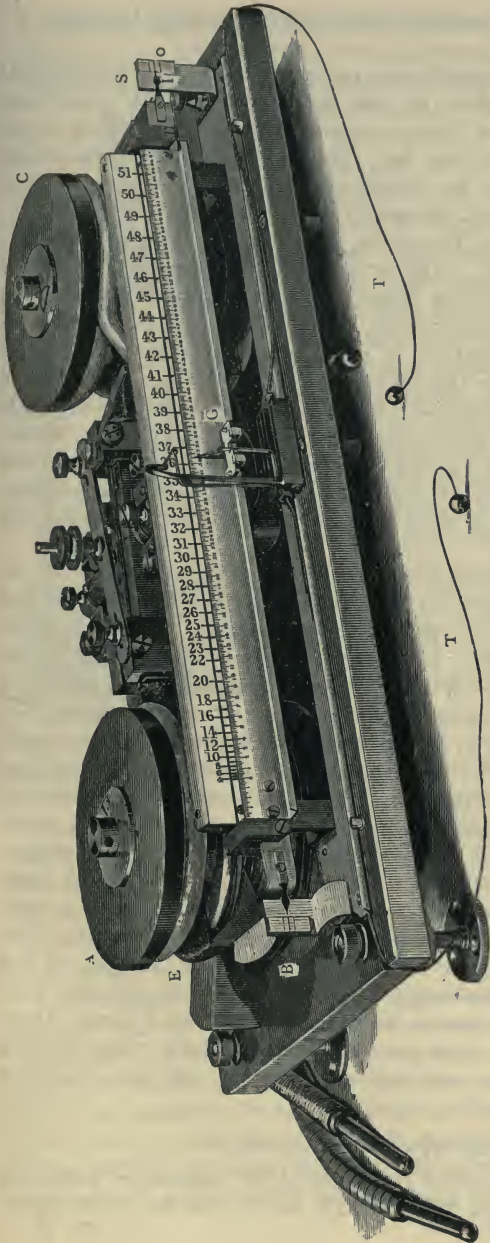

Fig. 734.—The Hekto-Ampere Balance (Range 6 to 600 Amperes).

that when no current is passing through the instrument the arm lies horizontally, as shown by the index *I* on the right-hand end pointing to the mark *o* on the fixed scale *S*. The electrical connections are such that when the current passes, the coil *E* tends to move upwards under the attraction of *A* and the repulsion of *B*, whilst the coil *F* tends to move downwards under the repulsion of *C* and the attraction of *D*. The polarities of the coils which give rise to these attractions and repulsions are indicated by the small letters *n* and *s* on the axes. As a whole, then, the beam of the balance tends to rotate in a clockwise direction, as indicated by the arrows *R*, and *R*<sub>2</sub>, and this tendency has to be counteracted by the little carriage *G* carrying the weight *w*, being slid along the beam until equilibrium is restored, and the index *I* again brought opposite the fiducial mark *o* on the scale *S*. The position of the carriage which produces equilibrium can be read off on a scale engraved on the beam, and this position, account being also

taken of the weight  $w$ , measures the current passing through the instrument.

As in the electro-dynamometer, the mechanical effect is proportional to the product of the currents in the fixed and movable coils, and therefore to the *square* of the current passing through the coils in series. Also a reversal of the current does not alter the directions of the forces, and therefore the instrument is adapted for the measurement of effects produced by alternate currents, irrespective of periodicity.

A complete instrument is shown in Fig. 734, in which a hekto-ampere balance is represented. The action will be understood from the foregoing description, especially as where possible the same letters have been used to denote the similar parts in the two figures. When in use the instrument is enclosed in a glass case to protect it from air currents which might disturb the balance; and the strings are for the purpose of dragging the travelling carriage  $G$  backwards and forwards on the beam. By a very ingenious device, which cannot be shown clearly on the small scale of the figure, the carriage is left quite free and clear on the beam as soon as the strings are slacked. The position of the index  $I$  on the beam relatively to the fiducial mark  $o$  is observed through a magnifying glass.

It will be readily understood that one of the great difficulties in the mechanical design of these current balances is to introduce the current into the movable coils without putting any constraint on the freedom of motion of the balance arm. It cannot be passed through the pivots or knife-edges because of the heating effects which would be produced there by the relatively high resistance of the loose and small contacts, such heating increasing very rapidly as the currents become larger. The current is, therefore, passed across this necessarily loose joint by very fine and flexible copper ligaments, so arranged as to produce as little constraint as possible. But since each fine ligament can only safely carry a small current, their number becomes very large when currents used in electric lighting are passed through. In one of the early instruments as many as 7,000 such ligaments were used without being able to pass a very large current. With so many ligaments, however flexible they may be, it is impossible not to interfere with the freedom of motion of the balance arm, and therefore for large currents the instrument has been modified, so that the large current traverses only the fixed parts, whilst the movable coils carry a much smaller current whose magnitude is measured on another balance and whose passage in and out does not present insuperable difficulties.

### III.—MEASUREMENT OF RESISTANCE.

Accurate knowledge of the ohmic resistance of the conductors used is of importance in all electrical work where electric currents are employed, but it

is especially important to the engineer dealing with large quantities of electric energy, for, as is pointed out over and over again in other parts of this book, this resistance is one of the factors in the production of the heating effect of the current. In most engineering operations this production of heat means wasteful loss of energy and is one of the main causes of the *inefficiency* of the machinery employed.

The definition of resistance and simple methods of measuring it have been given already (*see page 360*); it is proposed now to refer briefly to some of the more interesting and important forms of apparatus used in more accurate work, premising that the measurement of one resistance in terms of another probably admits of a higher order of accuracy than any other electrical measurement. It will be well first to consider the standards available.

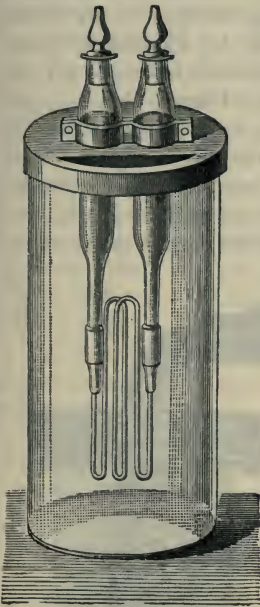

Fig. 735.—A Mercury Unit.

devised the standard resistance shown in Fig. 736, which aims at complying with the actual conditions of the official specification. The glass tube containing the mercury is, for compactness, bent into the form of a double or triple **U**, the ends being brought to enlarged tubes, filled with mercury, which form the electrodes. The whole is enclosed in a glass jar, which can be filled with water or some other liquid to bring the mercury in the tube to a known temperature.

Even in this form the unit is not at all convenient, and for most purposes wire copies of the unit or of one of its multiples or sub-multiples are employed. Now the resistance of a uniform wire depends (*see page 184*) on its length, cross-sectional area, and the specific resistance of its material. The latter varies with temperature, and therefore in constructing a standard coil it is necessary to make special arrangements for bringing the conductor to a

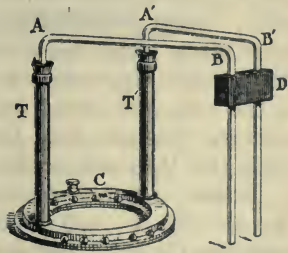

Fig. 736.—Standard Resistance Coil.



definite and known temperature. One of the best ways of doing this is to immerse the coil in a bath of liquid of known temperature, and to keep the temperature of the bath constant for a long time. But this necessitates a special construction of the coil, and especially of the electrodes. Many forms have been proposed and used. A good one devised by Dr. Fleming is shown in Fig. 736. The wire, made of platinum-silver and insulated with silk, is contained in the flat ring *c*, its two ends being soldered to the thick copper rods *A B*, *A' B'* which pass up through the ebonite tubes *T*, *T'*, without touching them. The ebonite block *D* mechanically supports the copper rods. If the ring *c* be now inserted in a vessel of melting ice, in a few hours the platinum-silver wire will be at a temperature of  $0^{\circ}$  C., at which its resistance is known in terms of the standard ohm. The outer ends of the copper rods can be placed in mercury cups outside the vessel containing the ice, and from these cups connections can be made to the other parts of the circuit.

Elaborate arrangements for producing definite temperature conditions would be unnecessary if we had a material whose specific resistance varied little or not at all with changes of temperature. In the Reichsanstalt in Berlin an alloy of nickel, manganese, and copper, called manganin, was prepared, which varied very little in resistance between  $0^{\circ}$  C. and  $100^{\circ}$  C., and more recently another alloy, called "Nickeline," has

been made, which has a small negative temperature coefficient—that is, its resistance diminishes with a rise of temperature instead of increasing, as is the case with metals generally. Such materials are now being largely used for resistance coils, but it is only by observations extended over many years that their ultimate suitability and permanence can be determined.

In many forms of standard coils the wire is covered with silk to insulate it; but silk is a bad conductor of heat, and its use renders it difficult to ascertain the exact temperature of the enclosed wire. Mr. E. H. Griffiths therefore designed a Standard Coil in which the wire is kept bare, and other methods of insulation are employed. These coils have during the last few years found great favour, and have been adopted by the Berlin Reichsanstalt. A particular pattern, as made by the Cambridge Scientific Instrument

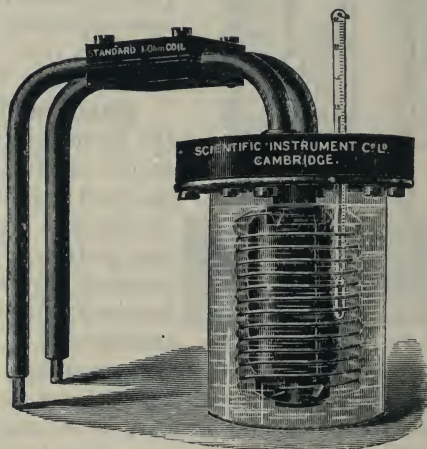

Fig. 737.—Standard Coil with Bare Wire.

Company, is shown in Fig. 737. A bare platinum silver wire is wound on a mica frame, and the coil and frame are immersed in a highly insulating oil, the ends of the resistance wire being attached to terminals of the usual pattern, as seen in the figure. The bare wire, being in contact with the oil, must rapidly take the same temperature, which can be read off on a thermometer introduced inside the windings. An additional advantage is that the wire can be heated electrically to a dull red heat, and annealed *in situ*; in this way any strain set up during the process of winding, and which might affect the constancy of the resistance, can be destroyed. In more elaborately constructed coils, a second wire made of a material with a higher temperature coefficient is wound alongside of, but insulated from, the standard wire, and its ends are brought to a separate pair of terminals. By measuring the resistance of this auxiliary wire, the mean temperature of the bath in the neighbourhood of the standard wire can be very accurately ascertained. It acts as an *electrical thermometer*.

Passing now to the consideration of methods of comparing unknown resistances with the above or other standards, the most accurate of these methods for dead resistances, that is, for resistances which contain no seat of E.M.F., is undoubtedly the Wheatstone bridge, the elementary principles of which have been already explained (*see* pages 355 and 361).

**Wheatstone Bridges.**—The Wheatstone bridge test for resistance is so frequently required that special boxes of coils are made up containing resistances suitable for the three arms N, P, and Q of Fig. 325 with the necessary

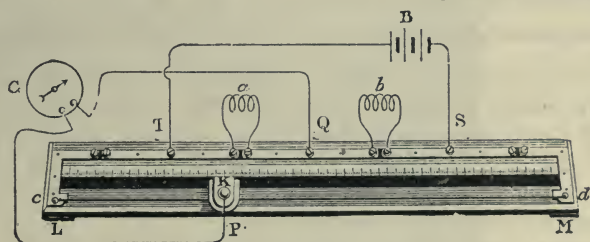

Fig. 738.—The Metre Bridge.

binding or terminal screws for connecting the galvanometer and the battery, and frequently with the necessary keys also. There is, however, a simple and useful form of bridge devised by Kohlrausch, and usually known as the "Metre" bridge, because the slide wire which is a prominent feature of the apparatus is frequently, but not necessarily, a metre long. This instrument is shown diagrammatically connected up in Fig. 738. It consists of a wire *c d* of platinum or other suitable material stretched taut between flat copper strips at L and M. The wire should be of uniform cross section and composition throughout, and L, T, Q, S, and M are flat copper strips arranged

and provided with binding screws as shown. Connected across gaps between the strips are the coils  $a$  and  $b$  whose resistances are to be compared. The battery  $B$  is placed between the screws  $s$  and  $r$ , and one terminal of the galvanometer is connected to  $q$ . The other terminal of the galvanometer is connected to a sliding key  $k$ , which can be brought to any position over the wire, and which when depressed connects the galvanometer to the wire. The exact point of contact  $p$  is indicated on the divided scale by the position of a fiducial mark on the top of  $k$ .

Comparing the connections in Fig. 738 with those in Fig. 333 it will be seen that  $r$  and  $s$  in Fig. 738 correspond to  $a$  and  $c$  in Fig. 333, whilst  $q$  and  $p$  in the former figure correspond to  $b$  and  $d$  in the latter, the galvanometer being placed in the part corresponding to the branch  $bd$  of Fig. 333. If we neglect the resistances of the copper strips, and denote by  $c$  and  $d$  the resistances of  $LP$  and  $PM$ , the two parts with which the wire is divided at  $P$ , we have, by the same kind of reasoning as is used on page 361—

$$\frac{a}{b} = \frac{c}{d}$$

whence

$$a = b \times \frac{c}{d} \quad (1)$$

If, then, we know the resistance of the coil  $b$  and the value of the ratio  $\frac{c}{d}$  we can calculate the value of the resistance  $a$ . But, assuming the wire fulfils the condition named above, the ratio  $\frac{c}{d}$  is that of the two lengths into which the bridge wire is divided at  $r$ , and these lengths can be read off on the scale.

The wire bridge is used for resistance measurements of the highest accuracy by a method originally due to Professor Carey Foster, and carried to a higher degree of refinement by subsequent experimenters. Consideration of space will not allow a full description of the apparatus and details of the modern developments of this method.

A very usual form of a box of coils for Wheatstone bridge work is shown in Fig. 739. the diagram of the connections for the test and the details of the values of the coils being given in Fig. 740. The letters  $p$ ,  $q$ ,  $s$ , and  $r$  in Fig. 740 are in the same electrical positions as the same letters in Fig. 738. and the two figures should be carefully compared. The place of the bridge wire is taken by the coils in  $pr$  and  $rq$ , known as the "ratio" coils, and it will be noticed that these coils have simple values which lead either to unit or decimal ratios. The advantage of this is obvious on reference to equation (1) above. The wire  $ps$  represents the unknown resistance, and balance is obtained by altering the ratio coils and the coils in  $qs$  until the galvanometer gives no deflection. In actual practice keys must be inserted both in



the battery circuit and in the galvanometer circuit, and, when testing, the battery key must be closed *before* the galvanometer key, so as to eliminate the inductive effects of any inductance in the resistance under test.

An arrangement of bridge coils widely used by the engineering department of the British Post Office is shown in Fig. 741. It is more compact than the box of Fig. 739, and has the additional advantage that the two keys required for the battery and galvanometer circuits respectively are mounted in a convenient position at the front of the box.

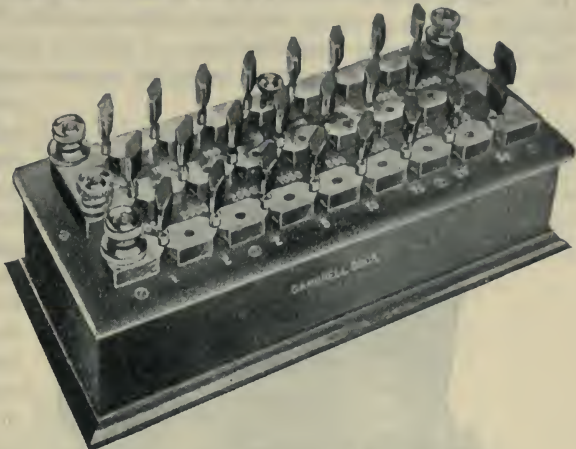

Fig. 739.—Ordinary Wheatstone Bridge; Coils only.

In some testing sets the galvanometer and the battery are also contained in the same box as the coils and keys.

**Liquid Resistances.**—In the testing of the resistance of electrolytes complications are introduced by the chemical effect of the current used in testing.

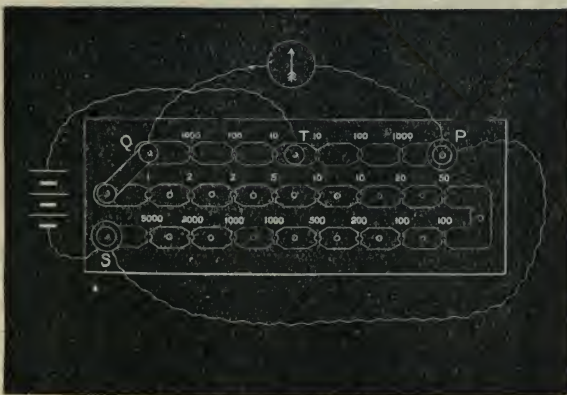

Fig. 740.—Diagram of Connections of Ordinary Wheatstone Bridge.

This effect sets up (see page 200) an E.M.F. which acts against the current, and diminishes its value. A similar diminution would be obtained by an increase of resistance, and, therefore, if the chemical effect be neglected, the resistance will appear higher than it really is. A simple method of compensating approximately for the E.M.F. generated by this action is to join up in the same circuit, with a galvanometer and a rheostat, the vessel containing the liquid, supplied with suitable elec-

trodes. The two electrodes are first immersed at a fixed distance from each other in the liquid. The deflection of the needle then indicates the current due to the difference of the E.M.F.'s of the battery and of the liquid working through resistances of the wire and of the column of liquid lying between the electrodes. The two electrodes are now to be removed farther from each other, so that the column of liquid becomes longer and the resistance

greater. The needle consequently shows a smaller deflection. If now by means of the rheostat such a resistance be removed from the circuit as will restore the original deflection, the resistance removed will be nearly equal to the resistance of the column of liquid added. The method is defective, inasmuch as the value of the polarisation E.M.F. may have changed in the interval between the taking of the two readings, though this is partially guarded against by returning to the same current.



Fig. 741.—A Post Office Wheatstone Bridge.

the integral values of the currents sent through the electrolyte be alternately the same and in opposite directions and follow one another very rapidly. Thus, using perfectly symmetrical *alternate currents* if in one second 100 currents in one direction alternate with 100 equal currents in the opposite direction, the polarisation set up by each one of the first set of currents lasting  $\frac{1}{200}$ th of a second is immediately destroyed by the following one of the second set in the next  $\frac{1}{200}$ th of a second.

If, therefore, the liquid resistance be placed in one arm of a Wheatstone bridge in which such symmetrical alternate currents are flowing instead of steady continuous currents, balance can be obtained, and the liquid resist-

Polarisation and the consequent back E.M.F. will be destroyed if

ance measured without being affected by polarisation. The only difficulty is that the ordinary galvanometers already described will not respond to such currents; which tend to deflect the needle in opposite directions much more rapidly than it is able to move. Instead of such a galvanometer we must employ in the arm Q P, Fig. 740, an instrument which will respond to alternate currents—for instance, either an electro-dynamometer (*see* page 733) or a telephone.

For this purpose Kohlrausch devised the special Wheatstone bridge shown in Fig. 742. It is a wire bridge, the wire being stretched over the scale E, F. A contact piece connected to J can be moved along the wire to adjust the balance. The third arm of the bridge is made up of coils, or a single coil in the box S, which contains four coils of 1, 10, 100, and 1,000 ohms respectively,

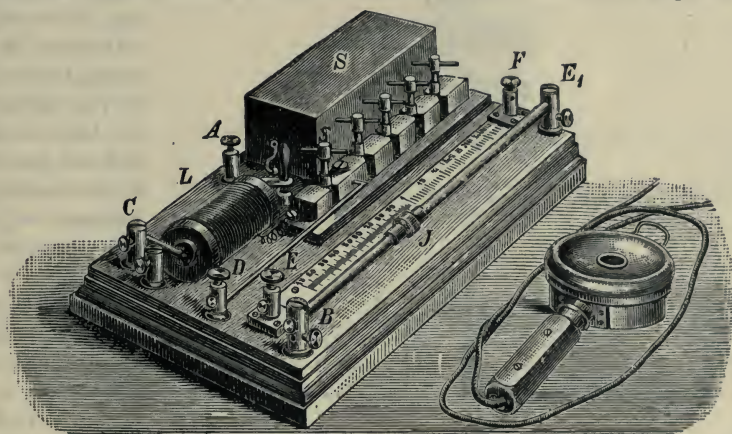

Fig. 742.—Kohlrausch's Bridge for Measurement of Liquid Resistances.

connected to the brass blocks in front of the box. The horizontal coil L is an induction coil (*see* page 427) worked by a battery joined to the binding screws A and C, and supplying alternate currents to the bridge. The alternate current terminals of L are connected, one to the slider J, and the other to the terminal D of the box S. The electrolyte to be measured is put in circuit between D and E, and the telephone is joined to the points E and F. The method of experiment consists in moving the slider J until no sound, or a minimum sound only, can be heard in the telephone. When this result is obtained the ordinary bridge law holds, namely—that the electrolyte resistance is equal to the resistance used in the box S, multiplied by the ratio of the resistances of the two segments of the slide wire E, F.

Better results would be obtained by replacing the battery and ordinary induction coil with its make and brake contact in the primary by a sinusoidal



alternate current derived from an alternate current generator of simple construction either directly or through a transformer. In this way currents can be obtained which more nearly fulfil the condition of being perfectly symmetrical on the positive and negative sides of the zero line.

A simple method, devised by the writer, not involving the use of alternate currents, is shown diagrammatically in Fig. 743. The electrolyte whose resistance is to be measured is contained in a fine tube  $AabB$  of thermometer glass, on the ends of which cups  $A$  and  $B$  have been fused for the purpose of containing the electrodes.  $R$  is a known wire resistance,  $G$  a galvanoscope,

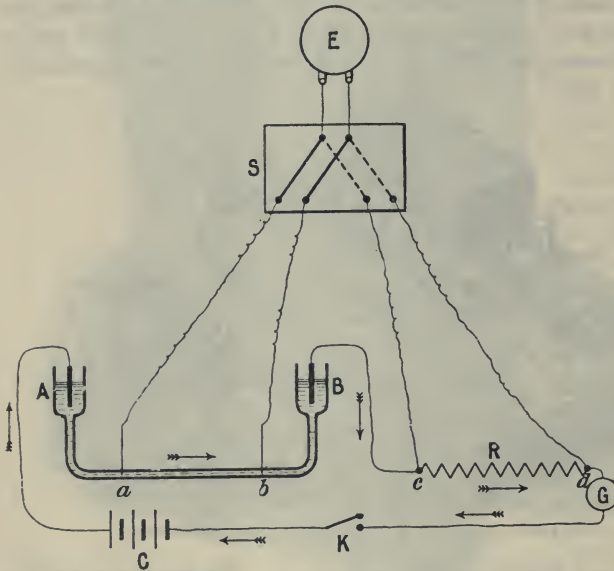

Fig. 743.—Measurement of Liquid Resistance by Fall of Potential.

to the switch  $s$ , to which also the ends  $c$  and  $d$  of the resistance  $R$  are connected as shown. On the other side of  $s$  is an electrometer (see page 373)  $E$ , which by means of  $s$  can be made to measure the P.D. between  $a$  and  $b$ , or the P.D. between  $c$  and  $d$ . If the current in the circuit as shown by the galvanoscope  $G$  is unchanged between the two measurements, we know, by Ohm's law, that the two P.D.'s are proportional to the resistances between the points  $a$  and  $b$  and the points  $c$  and  $d$  respectively. But, as we know the latter resistance, the former can be calculated. The result is free from the effects of polarisation, as the quantity necessary to charge the electrometer is too small to polarise the electrodes  $ab$  by its passage, and these electrodes are too far off the electrodes  $A$  and  $B$  to be affected by the polarisation there.

$c$  a battery, and  $K$  a break circuit key. On pressing the key  $K$ , a current flows round the circuit in the direction of the arrows, and the galvanoscope  $G$  serves to indicate when this current is steady. Two platinum wires  $a$  and  $b$  are sealed into the tube containing the electrolyte; these serve as testing electrodes, and are connected to

The method just described is known as the "fall of potential" method, and can also be used to compare wire or dead resistances, the unknown resistance taking the place of the electrolyte.

**Measurement of High Resistances.**—Although a wide range of resistances can be measured on the ordinary Wheatstone bridge, yet there is both an upper and a lower limit beyond which the method either ceases to be applicable or, what is perhaps much the same thing, ceases to be sensitive, the measurements being liable to serious errors. For instance, on the upper side, if the greatest ratio on the ratio arms be 1,000 to 1 and the largest resistance available in the third arm be 10,000 ohms, the bridge can theoretically measure up to  $10,000 \times 1,000 = 10,000,000$  or 10 megohms, and no farther. But long before this limit is reached it will be found that the method is not very sensitive. In practice, however, it is necessary to measure resistances of 1,000 megohms and more, and these are obviously far outside the above limit.

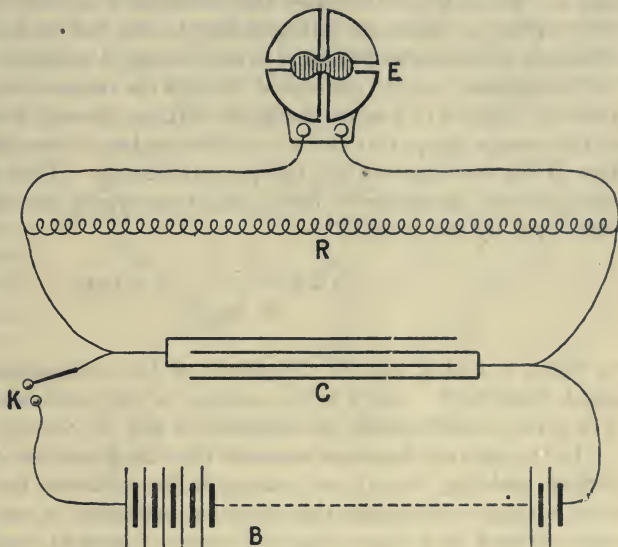

Fig. 744.—Measurement of High Resistance by Loss of Charge.

For such measurements, therefore, other methods must be adopted. The "fall of potential" method (*see above*) may be used if a large standard resistance of, say, 1 megohm, and a sensitive electrometer are available. The method of substitution (*see page 361*) can also be used, especially if when the standard resistance is in circuit the apparatus is so arranged that the galvanometer is heavily shunted and only a small known fraction of the battery P.D. is used, whereas with the high resistance the galvanometer is unshunted and the whole P.D. of the battery is employed to force the current through. In such a measurement the unknown resistance may be of the order of a million times the resistance with which it is being compared.

Another method, known as the "loss of charge" method, is entirely

different, and can only be used for the measurement of very high resistances. If a condenser of known capacity be charged and then discharged through a very high resistance, it can be shown that the *rate* at which the charge leaks out depends on the product of the capacity and the resistance, although the law is not one of simple proportionality.

One method of carrying out the test is shown diagrammatically in Fig. 744. The high resistance  $R$  to be measured is connected across the well-insulated terminals of an electrometer  $E$ ;  $c$  is a condenser of known capacity, and  $B$  a battery;  $K$  is a high insulation switch or key. The apparatus is connected up as shown, special attention being paid to all details of insulation on the side  $K$ . If the key  $K$  be closed the condenser  $c$  is charged, and the electrometer gives a deflection corresponding to the full E.M.F. of the battery. When the electrometer has come to rest the key  $K$  is opened and the terminals of the condenser are left connected through the resistance  $R$ . The condenser, therefore, begins to lose its charge by leakage through the resistance  $R$ , and as the charge disappears the P.D. of the condenser terminals and the deflection of the electrometer will fall proportionately. Time readings are to be taken of the electrometer deflections, from which the resistance  $R$  can be calculated by the formula:—

$$R = \frac{t_2 - t_1}{K \log \frac{d_1}{d_2}} \times 0.4343$$

in which  $d_1$  and  $d_2$  are the deflections of the electrometer at the times  $t_1$  and  $t_2$  respectively, and  $K$  is the capacity of the condenser. If the capacity  $K$  be given in microfarads the resistance  $R$  will be found in megohms.

In the above it has been assumed that the insulation of the condenser is perfect, and that there is no leakage in the condenser itself. If this be not so it is easy to determine the insulation resistance of the condenser by the same method, and then to apply the laws of parallel resistances to the case in which the resistance  $R$  and the insulation resistance of the condenser are both causing leakage. The method is used in testing the insulation resistance of submerged cables; as these have a capacity which can be ascertained, no other condenser is required, but the cable is charged up as indicated and then insulated, the loss of charge as it leaks through its own insulation resistance is observed, and the resistance calculated by the formula.

For the measurement of still higher resistances the method has been further developed, but these developments are beyond the scope of this work; they will be found described in books on electrical testing.

**Measurement of Low Resistances.**—For very low resistances such as are below the range of ordinary Wheatstone bridges special methods must be adopted.



The danger which has always to be guarded against in measuring low resistances is that the resistances of the contacts by which connections are made to the measuring apparatus should not affect the result. It will be readily understood that where the resistance to be measured is a few microhms or a small fraction of an ohm, the resistances of contacts and leads or connecting links, if not carefully eliminated or allowed for by the method of test, may be many times greater than the resistance of the conductor to be tested, and thus may entirely vitiate the result.

In Wheatstone bridge measurements the resistances of the contacts in the arms of the bridge obviously must affect the result, as in the equation assumed to be true when balance is obtained (*see* equation (1), page 740) the four resistances,  $a$ ,  $b$ ,  $c$ , and  $d$ , must be the total respective resistances of the four arms.

If one or more of these consists of a conductor resistance with an unknown contact or leading-in resistance of about equal or greater value, the equation, though still true, cannot be used for calculations, as the individual terms involve unknown quantities. The Carey Foster method already mentioned (*see* page 740) gets over the difficulty in most cases by taking double readings on the slide wire, the positions of test and standard or comparison resistance being interchanged for the second reading. With very low resistances, however, even this method must be very carefully applied.

*Kelvin Double Bridge.*—An earlier method proposed by Lord Kelvin eliminates the effect of contact resistances in another way. The arrangement is shown diagrammatically in Fig. 745, in which  $x$ , the resistance to be measured, and the standard resistance  $R$ , with which it is to be compared, are represented as thick bars. These bars are connected in series by the coupling  $g$ , whose resistance, though very small, may be comparable with that of  $R$  or  $x$ . In order to eliminate the influence of the electrodes by which the current enters and leaves, the resistances of the whole of the two bars are not compared, but only the resistance between the points  $c$  and  $D$  in  $x$  with that between  $A$  and  $B$  in  $R$ . At these four points,  $A$ ,  $B$ ,  $C$ , and  $D$ , branch circuits,  $A r_1 M r_4 D$ , and  $B r_2 N r_3 C$ , are led off containing the

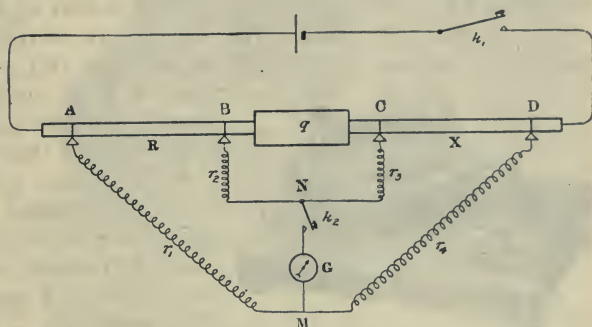

Fig. 745.—The Kelvin Double Bridge.

*Kelvin Double Bridge.*—An earlier method proposed by Lord Kelvin eliminates the effect of contact resistances in another way. The arrangement is shown diagrammatically in Fig. 745, in which  $x$ , the resistance to be measured, and the standard resistance  $R$ , with which it is to be compared, are represented as thick bars. These bars are connected in series by the coupling  $g$ , whose resistance, though very small, may be comparable with that of  $R$  or  $x$ . In order to eliminate the influence of the electrodes by which the current enters and leaves, the resistances of the whole of the two bars are not compared, but only the resistance between the points  $c$  and  $D$  in  $x$  with that between  $A$  and  $B$  in  $R$ . At these four points,  $A$ ,  $B$ ,  $C$ , and  $D$ , branch circuits,  $A r_1 M r_4 D$ , and  $B r_2 N r_3 C$ , are led off containing the

coils (adjustable)  $r_1$ ,  $r_2$ ,  $r_3$  and  $r_4$ , whose resistances are known and much greater than  $R$  or  $X$ . The resistances of these coils are to be adjusted until on pressing first  $h_1$ , and then  $h_2$  the galvanometer  $G$  shows no deflection. The mathematical condition to be satisfied in this case is:—

$$\frac{X}{r_4} - \frac{R}{r_1} + \left( \frac{r_3}{r_4} - \frac{r_2}{r_1} \right) \frac{q}{r_2 + r_3 + q}$$

This reduces to the much simpler condition

$$\frac{X}{r_4} = \frac{R}{r_1}, \text{ or } X = R \frac{r_4}{r_1} \quad (2)$$

if either—

$$q = 0 \quad (\text{i.}), \text{ or } \frac{r_3}{r_4} = \frac{r_2}{r_1} \quad (\text{ii.})$$

The first (i.) of these conditions ( $q = 0$ ) is that of the ordinary bridge, where the whole subsidiary circuit,  $B r_2 N r_3 C q B$ , is reduced to an electrical point of no resistance. The second condition (ii.) is *independent* of the value of  $q$ , the contact resistance, and, if satisfied, equation (2) will hold whatever be the value of this contact resistance.

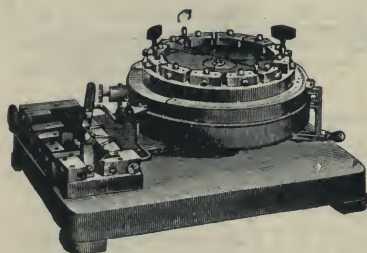

Fig. 746.—Kelvin Double Bridge (Slide Wire Pattern).

A wire bridge, as designed and made by Messrs. Siemens Bros. for carrying out this test, is shown in Fig. 746. It is intended to measure resistances from one-tenth of an ohm down to one-millionth (one microhm). A still more elaborate arrangement made by the same firm is shown in Fig. 747, the range being

from 10 ohms to 1 microhm when used as a double bridge. The standard resistance  $R$  is not included in the coils, but is to be inserted in the gap marked  $w_1$ , the test resistance being placed in the gap  $w_2$ , or *vice versa*. The galvanometer is inserted between the clamps  $G, G$ . The arrangement is not quite the same as that depicted in the diagram of Fig. 745, but is electrically equivalent. The box can also be joined up as an ordinary Wheatstone Bridge with a range from 10,000 to 0.1 ohm, and therefore it has in effect a range from 10,000 ohms to 1 microhm, which is very wide for one piece of apparatus.

*Fall of Potential Method.*—The fall of potential method already described for the measurement of liquid resistances (*see* Fig. 743) can be used for comparing low resistances, the bar to be tested taking the place of the tube  $AB$  and a low resistance standard the place of the resistance  $R$ . The method is obviously independent of the connecting resistance between  $b$  and  $c$ . Ordinarily, however, a sensitive galvanometer must take the

place of the electrometer *E*, and in that case care must be taken that the current tapped off by the galvanometer does not interfere with the accuracy of the test.

*Differential Galvanometer Method.*—The above method can be modified by using a specially designed *differential galvanometer* and connecting its two circuits to *ab* and *cd* respectively. In this case, however, one of the four contacts must be adjustable or one of the circuits of the galvanometer must be arranged to have its resistance varied in a known way.

*Ammeter and Voltmeter Method.*—The most satisfactory method for measuring low resistances, if the conditions permit, is that which takes advantage of the fundamental definition of electrical resistance (see page 182), as the ratio between the steady electrical pressure, or P.D., and the steady current which it produces in the conductor to which it is applied. The necessary condition is that the conductor shall be capable of carrying, without being sensibly heated, a current which can be measured in absolute measure



Fig. 747.—Kelvin Double Bridge (Coil Pattern).

(*e.g.* in amperes), and is sufficiently large to require a P.D. which can also be measured absolutely (*e.g.* in volts or millivolts). Should the conductor become heated by the necessary testing current, its resistance will thereby be changed and the test will either be vitiated or will require the temperature of the conductor to be measured in order that the results may be accurately interpreted. One advantage of bridge methods is that the testing currents used are, as a rule, so small that they do not sensibly affect the resistances employed.

This ammeter and voltmeter method, as it is called, is shown diagrammatically in Fig. 748. A battery *B*, which may conveniently be a secondary battery, supplies the current and is joined through the switch *s* in series with the resistance *x* (say a dynamo armature or other low resistance) which is to be measured and a galvanometer or ammeter *A*, whose readings give the current in amperes. Across the points *a* and *b* the electrical extremi-



ties of  $x$  is placed a shunt circuit consisting of a high resistance voltmeter or milli-voltmeter  $v$  and a key  $k$ . The switch  $s$  being first closed as soon as the current is steady, the key  $k$  is closed and  $v$  and  $A$  are simultaneously read. The resistance

$$x = \frac{v}{A},$$

provided the closing of the key  $k$  has not appreciably changed the current in  $A$ , or, in other words, provided that the resistance of the shunt circuit  $a k v b$  is so high that the current tapped off is inappreciable and cannot

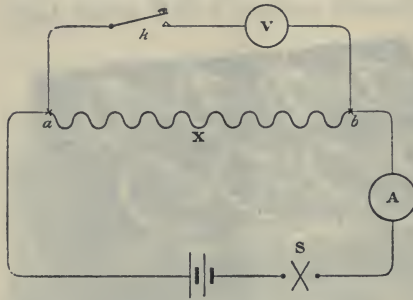

Fig. 748.—Ammeter and Voltmeter Method of Measuring Low Resistances.

be detected on  $A$ . If this condition be not fulfilled, it may still be possible to use the method provided that allowance is made for the current on  $a k v b$ . This can readily be done if the resistance of the shunt circuit be known.

*Other Methods.*—Professor Viriamu Jones, of Cardiff, worked out a modification, adapted to ordinary laboratory work, of Lorenz's method for the determination of the value of a resistance in

absolute measure, *i.e.* as a velocity in centimetres per second. This is specially applicable to the determination of low resistances, but its description would lead us too far.

#### IV.—RESISTANCES OF MATERIALS.

It is next proposed to deal with some of the most important results of the measurements of the resistances of various materials. From what has been already said it will have been gathered that the electrical resistance of a conductor is a distinct physical property of the material of which it is composed, just as the colour, density, weight, hardness, etc., of the same conductor are physical properties of the material. It is true that the actual resistance depends also on the dimensions, shape, etc., but so also does the weight; and therefore, in order to compare the numerical value of the physical property of electrical resistance of different materials, the results of actual measurements must be reduced to a standard size. We thus arrive at what has been already defined as the *specific resistance* of the material, which is simply the resistance of a piece one unit long and one square unit in sectional area. The process is analogous to that by which, in order to compare the densities of materials, we reduce the weights of actual pieces of various sizes all to one standard size, namely, the unit of volume.

Early experimenters not having an absolute unit of resistance, universally recognised, like the *ohm*, in which to express their results, had to be content to give tables of the *relative resistances* of the various materials, some particular material being taken as the standard of reference. This method is similar to that by which densities are tabulated relative to the density of water as *the* unit, the densities then being known as the specific gravities. In the electrical case silver, copper, platinum, and other materials have been from time to time selected as the standard materials, and tables of resistances relative to one or other of these will be found in the earlier editions of this book.

**Specific Resistances.**—Instead of such tables it will be more convenient for reference to give here the specific resistances of various materials expressed in ohms, and accordingly such specific resistances are set forth in Table IV. When the centimetre is taken as the unit length, as it is in the international c.g.s. (centimetre, gramme, second) system of units, the specific resistance of good conductors is too small to be written conveniently in ohms. In these cases the table gives the results of experiments in terms of the **microhm** (or *little ohm*), which is the *one-millionth* part of an ohm. On the other hand, when we are dealing with insulators, the ohm itself is too small a unit for convenience, and the results are given in terms of the **megohm** (or *great ohm*), which is *one million* ohms, and is used instead of the ohm whenever high resistances are being dealt with.

TABLE IV.—RESISTANCES OF MATERIALS.

Class of Material.	Material.	Resistance of one cm. length, one square cm. in section at 0° C. (except when otherwise stated). (Specific resistance.)	Resistance of one foot length, one square inch in cross section at 0° C.	Temperature variation (Values of). (See page 755.)
Pure Metals.	Silver (annealed) ...	1·461 microhms	6·90 microhms	+ '0040
	Copper (annealed) ...	1·561 —	7·37 —	'0043
	Copper (hard drawn) ...	1·647 —	7·78 —	'0039
	Gold (hard drawn) ...	2·195 —	10·35 —	'0038
	Aluminium (annealed)...	2·665 —	12·59 —	'0044
	Aluminium (hard drawn)	3·160 —	14·92 —	'0039
	Zinc ... ..	5·751 —	27·45 —	'0041
	Iron (annealed)... ..	9·065 —	42·85 —	'0063
	Platinum (hard drawn)	10·917 —	51·6 —	'0037
	Nickel (annealed) ...	12·4 —	58·6 —	'0037
	Zinc (annealed)... ..	13·048 —	61·75 —	'0044
	Tin (pressed) ... ..	13·360 —	63·06 —	'0036
	Tantalum ... ..	16·0 —	75·6 —	'0029
	Lead (pressed) ... ..	20·3 —	96·0 —	'0041
	Antimony (pressed) ...	35·2 —	166·2 —	
	Mercury ... ..	94·070 —	445 —	'0091
	Bismuth (annealed) ...	108 —	511 —	
Bismuth (compressed)...	132·65 —	627·5 —	'0054	

TABLE IV.—RESISTANCES OF MATERIALS—(continued).

Class of Material.	Material.	Resistance of one cm. length, one square cm. in section at 0° C. (except when otherwise stated). (Specific resistance.)	Resistance of one foot length, one square inch in cross section at 0° C.	Temperature variation (Values of) (See page 755.)
Alloys.	Phosphor bronze ... ..	8.48 microhms	40.05 microhms	+ .0005
	German silver ... ..	29.98 —	141.5 —	.00027
	Nickelin ... ..	40.62 —	191.7 —	.00021
	Platinoid ... ..	41.73 —	197.1 —	.00031
	Manganin ... ..	36.62 —	173 —	.0000175
	Constantan ... ..	47.05 —	222 —	— .000012
	Eureka ... ..	47.40 —	224 —	+ .000048
	Iron with 12% manganese	67.15 —	317 —	.00127
Carbon.	Carbon arc light ... ..	3,800 to 7,600 microhms	17,950 to 35,900	— .0005
	Carbon glow lamp ... ..	4,000 —	18,880 —	
	Carbon, graphite ... ..	23,000 to 42,000 —	108,600 to 198,000	
Electrolytes.	Water with 35% H <sub>2</sub> SO <sub>4</sub>	13.25 ohms	62.6 ohms	} — from .005 to .02
	Common salt (saturated)	14 —	65.2 —	
	Nitric acid ... ..	29.3 —	138.2 —	
	Copper sulphate at 10° C. (saturated) ... ..	33.7 —	159 —	
	Zinc sulphate at 10° C. (saturated) ... ..	50 —	236 —	
	Water (ordinary distilled)	72 megohms	340 megohms	} Negative
	„ (more carefully purified)	6770 —	32,000 —	
Insulators (Approximate).	Paper (ordinary) ... ..	3,000 megohms	14,160 megohms	} Negative and large
	Paper (parchment) ..	30,000 —	141,600 —	
	Glass(Bohemian) at 60°C.	42.5 × 10 <sup>6</sup> —	202 × 10 <sup>6</sup> —	
	Mica at 20° C. ... ..	84 × 10 <sup>6</sup> —	397 × 10 <sup>6</sup> —	
	Gutta-percha at 24°C....	450 × 10 <sup>6</sup> —	2,125 × 10 <sup>6</sup> —	
	Shellac at 28° C, ... ..	9 × 10 <sup>6</sup> —	42.5 × 10 <sup>6</sup> —	
	India-rubber at 24° C....	10.9 × 10 <sup>6</sup> —	51.8 × 10 <sup>6</sup> —	
	Glass (flint) at 20° C. ...	20 × 10 <sup>6</sup> —	94.4 × 10 <sup>6</sup> —	
	Ebonite at 46° C. ... ..	28 × 10 <sup>6</sup> —	132 × 10 <sup>6</sup> —	
Paraffin wax at 46° C. ...	34 × 10 <sup>6</sup> —	160.5 × 10 <sup>6</sup> —		

In the above table the third column gives the specific resistances in centimetre measure of the materials named in the second column under the physical conditions specified. The centimetre, however, is not a familiar unit in these islands, and therefore in the fourth column the resistances have been re-calculated for dimensions with which English readers will be more familiar, namely, for a length of one foot and for a cross section of one square inch. The multiplier is  $4.72 \left( = \frac{12}{2.54} \right)$ . For convenience the



various materials have been grouped into (a) pure metals, (b) alloys, (c) carbon, (d) electrolytes, and (e) insulators. The list is far from being exhaustive, but it embraces most of the materials in common use for electrical purposes.

A few general remarks may be made. The most striking characteristic of the numbers set forth in columns 3 and 4 is the enormous range in the resistances dealt with. Leaving out of the comparison the "practically infinite" resistance of dry air (not under the influence of *ionization*, see page 704), to which no numerical value is assigned, the ratio of the highest resistance in the table (that of gutta-percha) to the lowest (silver) would require a number containing 21 digits to express it. This number is far in excess of the numbers used even by astronomers to express the great distances comprised within the limits of the solar system, and is more of the order of the numbers used for stellar distances. Notwithstanding this range, the numbers given are the results of actual measurements, the methods of which have been briefly explained, except in the case of the measurement of the very highest resistances of insulators, the description of which would carry us too far.

The various sections of the table are in increasing order of magnitude, except in the case of the first two sections, where there is some overlapping. In the other cases the gap between the lowest resistance in one section and the highest in the preceding section is clearly marked, and is usually a wide one.

*Alloys.*—It is curious to note that the resistance of an alloy, as a rule, appears to have little or no relation to the resistances of the metals of which it is composed. In fact, it not infrequently happens that the specific resistance of the compound is higher than the resistance of the worst conductor which enters into its composition. Thus 21.17 microhms, the resistance of German silver, an alloy of copper, nickel and zinc, is much higher than 12.29 microhms, the resistance of nickel, the worst conductor of the three. We have, therefore, the paradoxical result that alloying nickel with better conductors than itself makes the product a much worse conductor. Similarly small traces of impurities in the metals have been found to affect the resistance to an extent out of all proportion to the quantity of the impurity present.

*Electrolytes.*—The specific resistances of a few electrolytic solutions used in batteries are given in the table; the figures relate to liquids with definite degrees of concentration. The resistance, as might be expected, varies with the concentration, and the following table calculated from results given by Wiedemann shows how great this influence is in the important case of solutions of different percentages of sulphuric acid in water:—

		Specific Resistance. (cm. units.)				
Sulphuric acid con- tained in 100 cubic centimetres water.	3.7 grammes	...	...	...	...	4.10 ohms.
	5.9 "	...	...	...	...	2.33 "
	11.42 "	...	...	...	...	1.21 "
	22.82 "	...	...	...	...	.72 "
	45.84 "	...	...	...	...	.66 "
	74.83 "	...	...	...	...	.89 "
	183.96 "	...	...	...	...	4.18 "

The behaviour of sulphuric acid is thus seen to be peculiar. Up to a certain point the resistance diminishes with the increase of concentration, but beyond this point resistance increases with further concentration. With solutions of common salt the resistance diminishes as the amount of salt increases.

*Water.*—The effect of impurities on the resistance is strikingly shown in the case of water. Two values are given in the table, one for ordinary distilled water, which for most chemical purposes may be regarded as pure, and the other for water still more carefully purified. The difference is very great, for the latter value is 94 times the former. In fact, the more carefully the water is purified the higher does its resistance rise; hence the probable hypothesis that absolutely pure water, if it could be procured, would be found to be a perfect insulator—that is, to have an infinite resistance. Electrically it is easy to detect the difference between two samples of distilled water, one of which has been distilled in ordinary glass vessels and the other in platinum vessels. By chemical tests both specimens would appear equally pure, and therefore the electrical tests, as we might expect, are much more searching than the chemical one.

*Insulators.*—The last section of the table deals with insulators, and a glance at the list of names shows that each of these, perhaps with the exception of mica, is a highly complex material, the composition of which may vary greatly in different specimens. The numbers given must therefore be regarded as approximate, and only correct for the particular material used in the actual experiment. They may, however, be regarded as of their right order. Moreover, the temperature coefficient is large, and therefore, in every case the actual temperature at the time of the experiment is given.

**Conductivity.**—In certain problems it is sometimes more convenient to express the results in conductivities instead of resistances, and therefore it is necessary to define the former term, and to say that it is the *reciprocal* of the resistance. Thus:

$$\text{conductivity} = \frac{1}{\text{resistance}}$$

and

$$\text{specific conductivity} = \frac{1}{\text{specific resistance}}$$

or, in symbols,

$$K = \frac{l}{\rho}$$

To calculate the conductivity of a uniform wire from the specific conductivity and the dimensions we have, by combining the above equations with the equation on page 184, the formula :

$$\text{conductivity} = K \times \frac{A}{l}$$

where  $l$  is the length and  $A$  the cross sectional area.

Lord Kelvin suggested that the unit of conductivity used in these equations should be called the **Mho** (*i.e.* ohm, spelt backwards), but the name has not come into very general use.

**Influence of Temperature.**—We have left to the last the consideration of this very important factor, the numerical effect of which is given in the last column of the table. The effect of temperature upon the resistance of conductors does not admit of exact mathematical expression ; but for ordinary purposes, when the range is not very great it may be represented by the following simple equation :—

$$R_t = R_0 (1 \pm a t.)$$

where  $R_t$  and  $R_0$  are the resistances at  $0^\circ \text{C.}$  and  $t^\circ \text{C.}$  respectively, and  $a$  is the coefficient given in the last column of the table on pages 751 and 752. The  $+$  sign is to be used when the resistance increases with the rise of temperature and the  $-$  sign when the resistance decreases as the temperature rises. The sign appropriate to each particular case is given in the table. It is worthy of note that the resistance of metals and alloys as a rule *increases* with the temperature, whilst the resistance of carbon, electrolytes, and insulators *diminishes* with rise of temperature.

As a metal with a negative temperature coefficient would be very useful in certain practical applications, electricians for many years endeavoured to make an alloy whose resistance should diminish as the temperature rose. The first successful outcome of these experiments was an alloy called "Manganin" produced at the Reichenstalt in Berlin, and consisting of 84 per cent. of copper, 12 per cent. of manganese, and 4 per cent. of nickel. The effect of temperature on the resistance of this alloy is very small indeed. From  $0^\circ \text{C.}$  to  $30^\circ \text{C.}$  the effect is positive, whilst from  $40^\circ \text{C.}$  to  $60^\circ \text{C.}$  it is negative. More recent examples are mentioned in the table, together with the value of the temperature coefficient.

A remarkable series of experiments on the effect of very low temperatures on electrical resistance were published a few years ago by Professors Dewar and Fleming, to the former of whom we owe so much for his experiments on liquid air. Using the very low temperatures obtain-



able with this intensely refrigerating substance, they investigated the changes which occur in the resistance of various materials down to more

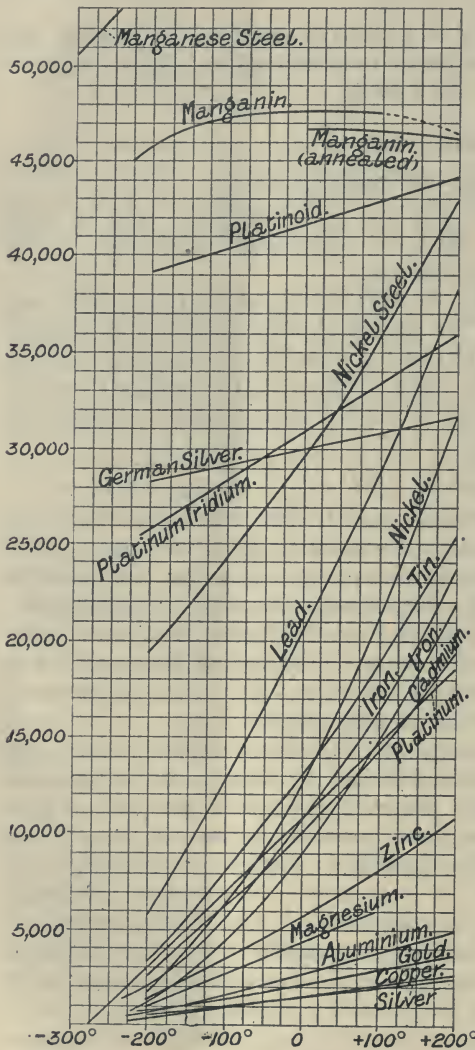

Fig. 749.—Influence of Temperature on Resistance.

of electrical theory, and well illustrates the scientific importance of making physical measurements at the lowest temperatures attainable.

than 200° C. below the freezing-point of water. The results are graphically depicted in the form of curves in Fig. 749, in which the temperatures are plotted horizontally and the resistances vertically. The diminution of resistance with fall of temperature is seen to continue for a long distance below 0° C., so much so that at -200° C. the resistance of copper is only  $\frac{1}{7}$  of its resistance at the freezing point. It is curious also that at this temperature copper is a better conductor than silver. A temperature 273° below the freezing temperature is known as the zero of what is called the absolute scale of temperature, and Professor Dewar pointed out that if the above diminution were to continue unchanged down to this temperature many of the metals would cease to have any resistance at all, and would become perfect conductors. There are, however, reasons for supposing that before this very low temperature is reached some profound physical change might occur which would interfere to prevent this remarkable result being attained. The whole investigation is full of interest from the point of view

## V.—MEASUREMENT OF CAPACITY

The energy stored in the electrostatic field in the neighbourhood of charged bodies and of conductors carrying electric currents, and, more especially, the variations of this energy, play such an important part in many of the applications of electricity that quantitative measurements in connection with it are absolutely essential. At pages 109 to 127 this particular method of storing energy electrically has been dealt with and the elementary theory developed; reference has also been made to the apparatus, Leyden jars and condensers, by which such energy can be concentrated and brought under control so that its electrical characteristics can be utilised or made available. Three equations,  $(c_1)$ ,  $(c_2)$  and  $(c_3)$ , for the energy are given on page 124, and it will be noticed that in the two last of these there occurs the symbol  $\kappa$ , denoting the so-called capacity of the condenser, which will be found defined on page 115. It is with the measurement of this quantity that this section is concerned.

It will be observed (*see* page 122) that the capacity of a condenser can be calculated if certain physical and geometrical quantities are known, but in practice it is more difficult, in most cases, to ascertain these quantities than to make a direct measurement of the capacity itself, or, simpler still, to ascertain the capacity by comparison with that of a standard condenser.

In such measurements or comparisons use is made of the fundamental equation connecting  $Q$  the charge,  $v$  the potential difference of the charged conductors, and  $\kappa$  the capacity. This equation is:—

$$Q = \kappa v \quad (1)$$

the practical units involved being (*see* page 123) given by the equation:—

$$\text{Micro-coulombs} = \text{microfarads} \times \text{volts} \quad (2)$$

**Comparison with a Known Capacity.**—The simplest method is to compare the charges of two condensers both charged to the same P.D.; for we have from (1)

$$v = \frac{Q_x}{\kappa_x} = \frac{Q_s}{\kappa_s} \quad (3)$$

and therefore

$$\kappa_x = \kappa_s \frac{Q_x}{Q_s} \quad (4)$$

where the sub-script letters  $_x$  and  $_s$  refer to the tested and the standard condenser respectively.

The ratio of the charges  $Q_x$  and  $Q_s$  can be readily ascertained by charging or discharging the condensers through a *ballistic galvanometer* (*see* page 722). The connections for such a test are given diagrammatically in Fig. 750. The standard condenser  $s$  is similar to that shown in Fig. 106,

whilst the condenser  $X$  to be tested is a piece of cable coiled up in a tank  $T$  of water from which its two ends project. The insulation is carefully pared off these ends exposing the inner conductor and the exposed surface of the insulating material is very carefully cleaned. The conducting plates of this cable condenser are the inner conductor and the water of the tank between which the insulation material of the cable lies as a dielectric. Connection is made to the water conductor, the water of the tank, by the wire  $w$ . The wire  $w$  is also joined to one pole of  $s$  and is then connected through the ballistic galvanometer  $B.G.$  to the pole  $N$  of the testing battery. The other pole of  $s$  and the insulated copper of the cable are joined respectively to two of the ways of a three-way plug switch  $w$ , the third way of which

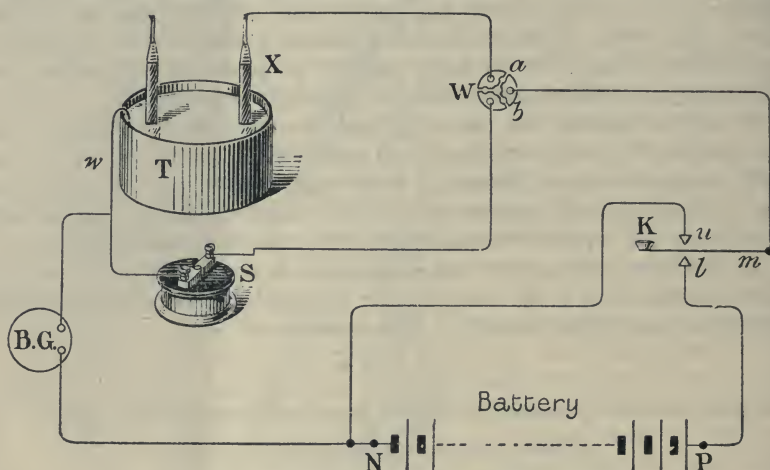

Fig. 750.—Comparison of the Capacities of Two Condensers.

is connected to the movable tongue of the highly insulated key  $\kappa$ . Finally the lower contact  $l$  of the key is joined to the pole  $P$  and the upper contact  $u$  to the pole  $N$  of the testing battery.

The method of test is first to close the gap  $b$  of  $w$  and to depress the key  $\kappa$ . This charges the standard condenser through  $B.G.$ , the limit ( $d_1$ ) of the first throw of which is to be noted. When the spot of light has come to rest  $\kappa$  is released so as to rest against the upper contact  $u$ , and the first throw of  $B.G.$  in the opposite direction, as  $s$  discharges through it, is to be noted. This throw should also be approximately equal to  $d_1$ , if the apparatus is properly adjusted. The charge or discharge  $Q_s$  of the condenser is connected (see page 723) with this throw  $d_1$  by the equation

$$Q_s = k \sin \frac{d_1}{2}$$



but for the small angles of the deflection of a sensitive reflecting galvanometer it is approximately correct to neglect the difference between an angle and its sine and to use the simpler equation

$$\Omega_s = k \frac{d_1}{2}$$

The above experiments are now repeated on the cable condenser with the gap  $a$  of the three-way switch plugged instead of the gap  $b$ . If the deflections, or their mean, now obtained are  $d_2$ , we have

$$\Omega_x = k \frac{d_2}{2}$$

and therefore finally by using equation (4) above:—

$$\kappa_x = \kappa_s \frac{d_2}{d_1} \quad (5)$$

To make sure that the battery voltage, which has been assumed to be constant, has not changed during the tests the experiments with the standard should be repeated after the experiments with the cable, and the deflection  $d_x$  should be reproduced.

The experiments as above described appear fairly simple, but several practical considerations have to be kept in view to ensure accurate results.

**Insulation.**—In the first place good insulation especially of the  $+$  end of the battery and the apparatus connected to it is absolutely essential.

Common keys and switches will not do, and much ingenuity has been exercised in devising high-insulation apparatus for these and similar tests. Instead of the conducting parts (binding screws, contacts, etc.) being mounted, as is usual for ordinary work, on a thin ebonite base, they are placed at the top of ebonite columns which are themselves mounted on the ordinary base. Special arrangements are also made to ensure that in the manipulation of the key the operator does not "earth" any insulated circuit by contact with his fingers.

A modern "high-insulation" key, made by Mr. R. W. Paul, and suitable for the test just described, and for more complicated tests, is shown in Fig. 751. The key is, in fact, a double key, and for our present purpose only one half of it is required. The upper and lower contacts,  $u$  and  $l$  of

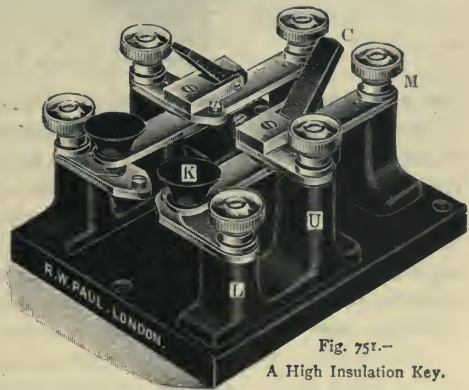

Fig. 751.—  
A High Insulation Key.

Fig. 750, are carried by the ebonite columns *U* and *L*, which are substantial in design and very securely fastened to the base. Each column also carries a binding screw for making connection to the contact, etc. The movable tongue which plays between the contact and its binding screw is carried by the

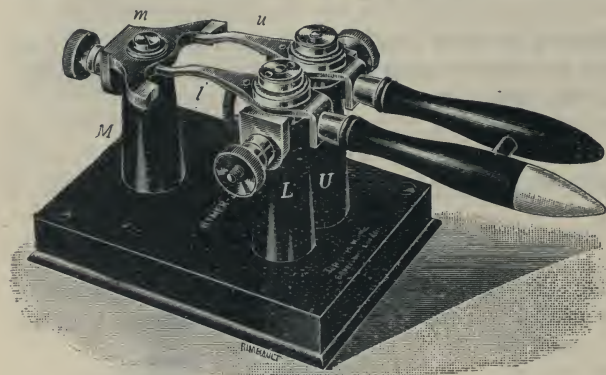

Fig. 750.—Rymer-Jones' High Insulation Key.

ebonite column *m*. This tongue can be depressed either by pressing the ebonite finger stud *F* or by rotating an ebonite cam *c* which has three positions—one for the lower contact, one for the upper, and one holding the tongue clear of each contact and therefore

insulating the part of the circuit attached to the binding screw *m*.

Another widely used but different pattern of key, designed by Mr. Rymer-Jones, is shown in Fig. 752, as made by the India Rubber, Gutta Percha and Telegraph Works Company, Limited. In this pattern two levers with long ebonite handles, one of which is tipped with ivory, are mounted at the top of stout ebonite columns *L* and *U*. These levers have binding screws attached to their metal parts, and take the place of the upper and lower contacts, *u* and *l*, of Fig. 750.

The movable tongue of the other pattern is replaced by the fixed metal piece *m*, mounted with its binding screw on the ebonite column *m*. This metal piece carries two platinum contacts, each of which can be touched by one, and by one only, of the metal fingers of the levers. An ebonite cross strut is attached to one of the handles, and an examination of the key will show that this ensures that the two fingers *u* and *l* cannot simultaneously be in contact with the metal piece *m*. The key is brought into circuit as shown in Fig. 750, the reference letters in the two figures being the same.

Another piece of apparatus in Fig. 753 also requires to be highly insulated, namely, the change over plug switch *w*. This is accomplished as in the keys by mounting the metal parts on the top of ebonite columns, as shown

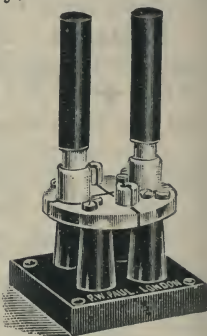

Fig. 753.—High Insulation Plug Switch.

in Fig. 753, which is self-explanatory. The vertical metal extensions round the plug holes are safety devices to prevent the central pin of the plug, assisted by the leverage of the long columns, pressing the metal plates out of position, for when the plug is pushed home the outer periphery of these extensions presses against a hollow cylinder guard carried on the bottom of the plug which, therefore, takes up the pressure. It should be noticed that the ebonite handles for manipulating the plugs are exceptionally long, so as to insulate the metal parts from contact with the operator.

Lastly, the galvanometer terminals are also well insulated from one another so as to prevent leakage from one terminal to another, and to ensure, as far as possible, that in the impulsive rush of current the whole charge or discharge shall pass through the galvanometer coils.

**Absorption.**—The other difficulty experienced in measuring the capacity of condensers with solid dielectrics is caused by the phenomena of electric absorption, which have been referred to at page 125. The effect is to cause the charge readings to be too high and the discharge readings to be too low. For moderate accuracy in testing mica or paraffined paper condensers the mean of the two sets of readings may be taken, but with long gutta-percha insulated cables the phenomena are more troublesome, and much ingenuity has been expended in elaborating tests which by taking time readings and in other ways are designed to eliminate or allow for the effects of absorption. These more or less elaborate methods of testing are beyond the scope of this section, though it may be possible to devote some attention to them in the technological section.

**Direct Measurement of Capacity.**—If a standard condenser be not available then, still using a ballistic galvanometer, the deflections produced by charges and discharges are observed, and we have to determine the capacity by the equation:

$$Q_x = \kappa_x v = k \sin \frac{d}{2}$$

If the ballistic constant ( $\kappa$ ) of the galvanometer and the voltage of the battery were known the problem would be solved, but instead of determining these it is usually simpler to calibrate the galvanometer by means of a continuous current derived from the same battery as is used for the ballistic tests. The voltage of the battery need not then be determined, as it will cancel out from the final equations, as the continuous current will be a function of this voltage and the resistances on circuit. The law connecting a steady deflection produced by a continuous current and the ballistic throw due to a sudden discharge can be ascertained from the theory of the galvanometer, and thus the capacity of the condenser can be calculated.



The necessity of introducing a correction for "damping" (*see* page 724) for the ballistic throw must not be overlooked, for such damping diminishes the magnitude of the ballistic throw, but has no effect on the steady deflection.

Other methods of measuring capacity, especially those depending on the use of alternate currents, will more conveniently be considered later, as will also the measurement of electric power and energy, already partly dealt with on pages 377 to 386.

## CHAPTER XX.

## ALTERNATE CURRENT MEASUREMENTS.

## I.—ELEMENTARY PRINCIPLES.

THE rapid development of the use of alternate currents, both mono- and poly-phase, for engineering purposes, has rendered necessary the elaboration of systems of measurement, and the design of the necessary instruments, to enable the engineer and the scientist to apply to alternate current circuits and quantities the same accuracy of measurement which many years previously so powerfully contributed to the development of the use of continuous currents.

The accurate measurement of alternate currents is rendered difficult by the rapidity with which the changes follow one another even with the currents of low periodicity which are used in some systems of power transmission. The lowest periodicity which has yet been used on any extensive scale has no less than 25 complete alternations per *second* (25  $\sim$ ), but in experimental work periodicities from this up to millions per second have been employed. Taking, however, the common periodicities of from 25 to 130  $\sim$ , it is evidently not an easy matter to devise an instrument which shall record faithfully, and with all details shown, the various changes in the value of the current even in a few successive alternations. We say *record* advisedly, because even if we had an instrument similar to the mirror galvanometer, which would cause a spot of light to move over a scale so as to indicate the value of the current from instant to instant, the human eye would be quite unable to follow the movements and to read the successive deflections accurately. The disturbing factor, apart from the impossibility of writing down the various values with sufficient rapidity, arises from the persistence of impressions on the retina which physiologists say lasts about one-eighth of a second. With a periodicity of 25  $\sim$ , more than three alternations would be completed in one-eighth of a second, and thus before the impression of the first deflection observed had died away the impressions due to the second and third alternations would all be received. The result would be a confused blur, in which no individual deflection, except, perhaps, the mean values of the extreme ones, could possibly be distinguished.

To such a state of perfection has modern instrument-making been carried that instruments, known as "Oscillographs," have been constructed which will faithfully follow every fluctuation of a current of a periodicity of 100 to 150  $\surd$  or more, and from such instruments a photographic record of a few successive alternations can be obtained. It is even possible that they may be modified to give a continuous record of several hundred successive alternations. The deflections can also be projected on a screen in such a way as to display the mean shape of the curve (say, such curves as are illustrated in Fig. 514) for many successive alternations.

Much has been done during the last few years towards the perfecting of such instruments which, besides having rendered important assistance in research work, are now becoming recognised as being able to give valuable information to central station engineers. They are still somewhat difficult to adjust and keep in order, but with further improvements in details these difficulties will tend to become less. It will, however, be more convenient to deal first with instruments more suitable for everyday use.

For most purposes it is not necessary to obtain a record of all the changes in the value of the current from instant to instant; we need only to know the mean values either of the current itself, or of some function of the current. The actual mean of the values of a current which is symmetrical in magnitude and shape on the two sides of the zero line is, of course, zero, for every  $+$  value on one side will be cancelled by an equal  $-$  value on the other side. We can, however, speak of the mean value of either the  $+$  or  $-$  loops, and can regard it as being obtained by drawing a sufficient number of equidistant vertical ordinates, as in Fig. 754, adding all the lengths of these ordinates together, and dividing by their number. The curve  $A C B$  in this figure is one loop extending over half a period ( $180^\circ$ ) of a sine curve (see page 540). The mean value of the vertical ordinates is  $0.635 \left( \frac{2}{\pi} \right)$  if  $N C = 1$  (Sine  $90^\circ$ ). Drawing  $A a$ , an ordinate having this value on the scale of the figure, and completing the rectangle  $A a b B$ , we obtain a figure equal in area to the space  $A C B N A$ , enclosed by the curve  $A C B$  and the base line  $A N B$ . If, as usual, the ordinates represent the values of the current at successive instants, an instrument that would indicate the *mean* value of these currents would give a deflection equal to the deflection produced by a continuous current of the value  $A a$  or  $B b$ . In other words,  $A a$  is the value of the equivalent simple continuous current.

An alternate current does not consist of loops such as  $A C B$ , in which the values are all  $+$  or all  $-$ , but of a succession of  $+$  and  $-$  loops rapidly following one another. An ordinary galvanometer, which is



deflected in opposite directions by  $+$  and  $-$  currents, would not be deflected at all by a true alternate current, for before it would be able to respond to an impulse in the  $+$  direction it would receive an equal impulse in the  $-$  direction. This is because the period of the free swing of the suspended apparatus in the galvanometer usually covers the time of several, and sometimes of a great number, of the alternations of the current. Such instruments are therefore useless for ascertaining the mean value of the current unless the latter be first rectified by a synchronous commutator, in which case it ceases to be an alternate current.

The case, however, is different with those instruments which deflect

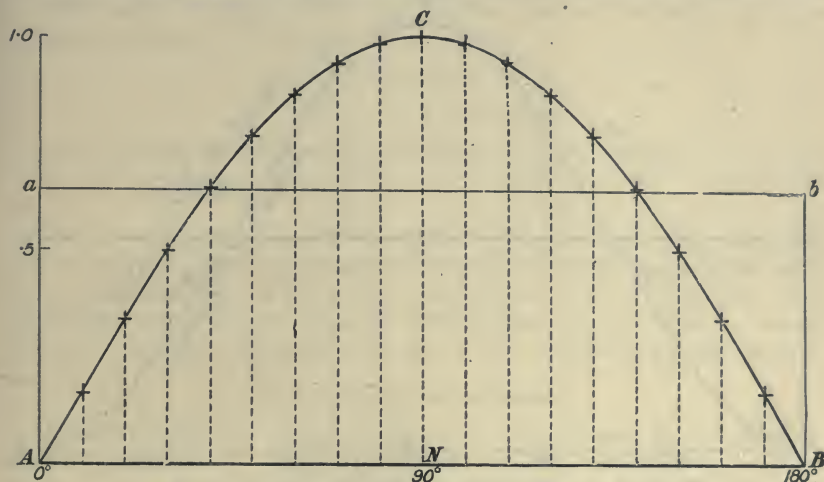

Fig. 754.—Mean Value of the Sines for One Loop of a "Sine Curve."

in the same direction whatever be the direction of the current. Any instrument whose deflections are proportional to the *square* of the current fulfils this condition, for it must be remembered that the square of a  $-$  quantity is always  $+$ , and therefore produces a similar effect to the square of an equal  $+$  quantity.

Now it has been shown in detail above (*see* page 734) that the Siemens' Electro-dynamometer fulfils this condition, which must be satisfied in all instruments required to measure accurately alternate currents; and there are other instruments which fulfil it approximately. It therefore becomes important to enquire how the indications of such instruments are to be interpreted when the readings are due to a rapidly alternating current. If the law of the instrument be that the deflections are strictly proportional to the square of the current, then the deflection produced will indicate the *mean value* of the *squares* of all the rapidly changing

currents that are passed through it. Further, if the instrument has been calibrated with continuous currents, and a scale of amperes marked on it, the *scale* will be proportional to the *square roots* of the deflections. Any fluctuating current value read upon this scale will be the value of the *square root of the mean value of the squares of the currents*. This is frequently referred to as the **square root of the mean square**, or as the **root mean square** (r. m. s.).

What is the relation between the "square root of the mean square" and the "mean value" of the current? It is quite obvious that they are not the same thing—in other words, that the mean of the squares of a series of numbers is not the same as the square of the mean.

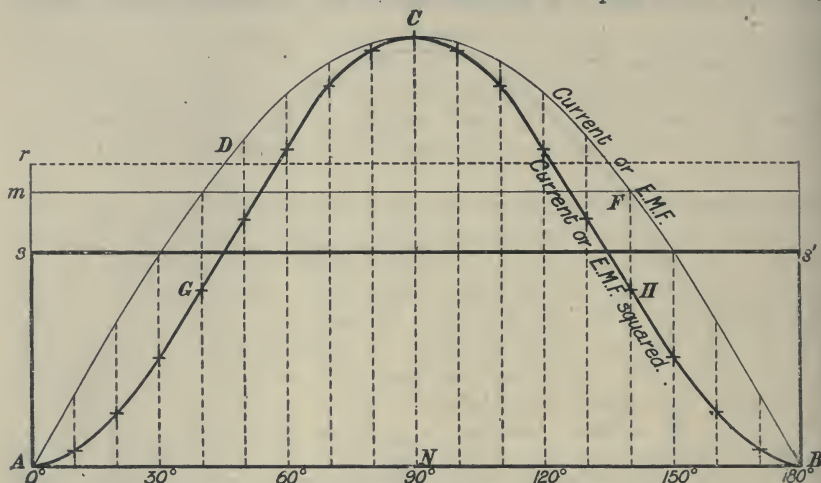

Fig. 755.—Values of the "Mean Square" and the "Root Mean Square" (Sine Curve).

For consider, as a simple example, the first seven natural numbers and their squares, viz. :—

$$1, 2, 3, 4, 5, 6, 7$$

$$\text{and } 1, 4, 9, 16, 25, 36, 49.$$

The mean value of the first line is 4, whilst the mean of the second line is 20, whose square root is 4.47, which is appreciably greater than 4. With a series of proper fractions and their squares the difference would be the other way. It is also obvious that the ratio of the two quantities will depend on the law of formation of the numbers, that is, on the curve connecting their successive values. For reasons previously given (page 539) we shall only examine the case where the current curve follows a sine law.

In Fig. 755 the curve ADCFB is our usual sine curve, whilst AGCHB is the curve for the *squares of the sines*, the maximum ordinate NC

in each case being = 1. It is clear that the ordinates of the latter curve are always less than the corresponding ordinates of the former, except at the points A, C, and B, where they are equal to one another. The mean value in the latter case must, therefore, be less than in the former, and by following the same procedure as before we find it to be equal to  $\frac{1}{2}$  (if  $NC = 1$ ).  $As$  represents this ordinate, and  $As's'B$  the corresponding rectangle equal in area to the figure  $AGCHBNA$ . If we take the square root of  $As$  we obtain the ordinate  $Ar$ , which represents the value of the *root mean square* of the sine curve  $ADCFB$ . For comparison we have also inserted the mean value  $Am$  of the sine ordinates as previously obtained.

We have, therefore, when the current follows the sine law, the following numerical relations:—

$$C_{\text{mean}} = 0.635 \times C_{\text{max}} = \frac{2}{\pi} C_{\text{max}}$$

$$(C^2)_{\text{mean}} = 0.500 \times C_{\text{max}}^2$$

$$\sqrt{(C^2)_{\text{mean}}} = C_{\text{r.m.s.}} = 0.707 \times C_{\text{max}} = \frac{C_{\text{max}}}{\sqrt{2}}$$

and therefore  $C_{\text{mean}} = 0.900 \times C_{\text{r.m.s.}}$

or the actual mean value of the current will be 10 per cent. less than the value given by the instruments referred to above if the latter have been calibrated by using steady continuous currents. This is a very important result, but it must not be forgotten that it is only strictly true for "sine law" currents or E. M. F.'s and "square law" instruments.

## II.—CURRENT MEASUREMENT.

**Instruments.**—As already pointed out, the Siemens electro-dynamometer (page 733) is directly available without modification for the measurement of alternate currents, provided it be remembered that, as usually calibrated, the current measured is the r. m. s. current, and not the mean current. The Kelvin current balances, described at page 734, are also available, provided the readings be properly interpreted, for here again the current indicated is the r. m. s. current, or, as it is often called, the *virtual current*.

In addition to these instruments, which accurately measure the mean square of the currents passing through them, we have those instruments already described, in which the moving part includes a small quantity of soft-iron, which for continuous currents becomes saturated before the deflection reaches the scale reading. Such are the "Magnifying Spring Ammeter" (Fig. 316), and a large class of "Gravity" ammeters, one of which has been illustrated and described at page 351. In these instruments the magnetism of the soft-iron needle is reversed when the current in the conductor reverses, and therefore the deflection is in the same direction with both  $+$  and  $-$  currents. Since, however, because



of the magnetic properties of iron, the law connecting deflection with current is not a simple one, as in the Siemens and Kelvin instruments, the instrument should be *calibrated* if possible *with an alternate current*. Moreover, this alternate current should have *the same periodicity* as the currents to be measured, because the effects of the hysteresis of the soft iron will depend on this periodicity. If, therefore, the instrument is used for currents of widely different periodicities, a separate calibration table or scale should be used for each periodicity.

One precaution is essentially necessary in the design of all measuring instruments through which alternate currents pass, and that is, not to have any large masses of solid metal in the neighbourhood of the alternate currents. Such masses of metal would have set up in them "eddy" currents induced by the changing currents in the conductors, and these "eddy" currents, besides perhaps dangerously heating the metal, would react on the original currents, producing disturbances whose effects it is impossible to bring under calculation. If, for any cause, a mass of metal must be so placed, it should, if possible, be divided across the paths of the eddy currents, so as to cut down the latter to a negligible magnitude. It may be noticed that the main parts of the Siemens electro-dynamometer (Fig. 732) are of wood.

### III.—PRESSURE MEASUREMENT.

With the limitations and precautions set forth above as applying to electro-magnetic ammeters, voltmeters of similar types may be used on alternate-current circuits, provided an additional source of complication is not lost sight of. This arises from the inductance of the instrument, the effects of which are similar to those which it produces in all alternate-current circuits. Thus the current through the instrument does not depend on the resistance of the voltmeter circuit, but upon its impedance, a quantity which changes with every change of periodicity and wave form. The current will also lag behind the impressed P. D., the tangent of the angle of lag being  $\frac{\phi L}{R}$  (see page 543). The factor depending on the circuit is  $\frac{L}{R}$ ,\* and this quantity should be made as small as possible. Now it is easy to make R large; in fact, we have seen that this is one of the conditions for voltmeter working. But if R consist entirely of the deflecting coil of the voltmeter, a large value of R will usually mean

\* NOTE.—The quantity  $\frac{L}{R}$  is known as the *time-constant* of the circuit, whose resistance is R and inductance L. In the electro-magnetic system of measurement the quantity L is of the order of a length, and the quantity R is of the order of a velocity. The ratio of the two is therefore a time. If a steady E. M. F. be suddenly introduced into such a circuit the current will be found to rise to 36·8 per cent. of its final value in the time  $\frac{L}{R}$  seconds if L be measured in *henrys* and R in *ohms*.

a large value of  $L$ , which is what we do not want. It is, therefore, necessary to add to the voltmeter circuit as much non-inductive resistance as may be possible without reducing the current so far that the readings of the voltmeter become unreliable. Every ohm of such resistance added increases the value of  $R$  without affecting  $L$ , and in this way the value of  $\frac{L}{R}$  may be considerably reduced. It is further obvious, from what has been said, that the voltmeter, except it be of the electro-dynamometer type, must be calibrated for the particular periodicity on which it is intended to use it, and that it will read *virtual volts* (see page 767).

**Electrostatic Voltmeters.**—On account of the disturbances and uncertainties introduced by inductance into all electro-magnetic voltmeters, attention has been directed to the evolution of electrostatic instruments adapted to the working conditions of the more commonly used alternate-current circuits. Theoretically the Kelvin quadrant electrometer (page 374) can be connected up so as to give a steady deflection when an alternate P. D. is applied to the quadrants. As ordinarily connected it is used *heterostatically*, that is, the electrification and potential of the needle is quite distinct from either of the potentials

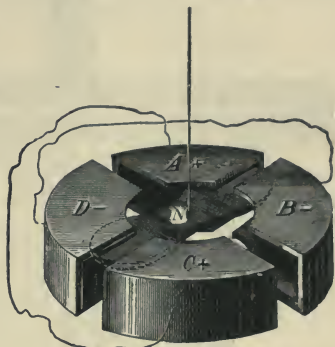

Fig. 756.—The Quadrant in Lord Kelvin's Electrometer.

whose difference it is required to measure. When so used, the torque  $T$  tending to deflect the needle is given approximately by the formula—

$$T = k (A - B) \left( N - \frac{A + B}{2} \right) \dots \dots \dots (1)$$

where  $A$ ,  $B$  and  $N$  stand for the potentials of the quadrants  $A$  and  $B$  (Fig. 756) and the needle  $N$  respectively, and  $k$  is a constant depending on the construction, etc., of the instrument.

The instrument, however, may be used *idiostatically*, that is, only those potentials may be employed the difference of which is required. In this case the needle must be connected electrically to one pair of quadrants so as to be at the same potential as that pair. Let us suppose that the needle is connected to the quadrants  $A$ , and that therefore  $N = A$ . The above formula then becomes

$$\begin{aligned} T &= k (A - B) \left( \frac{A - B}{2} \right) \\ &= \frac{k}{2} (A - B)^2 \end{aligned}$$

or the deflecting torque will depend on the *square* of the difference of potentials of the quadrants, and therefore will always be in the same

direction. That this will be so is also physically apparent, because if the electrification of the needle changes sign from  $+$  to  $-$ , or *vice versa*, at the same time that the potentials of the quadrants change sign, the acting forces will still tend to pull the needle in the same direction as before. We see, therefore, that if, with the needle so

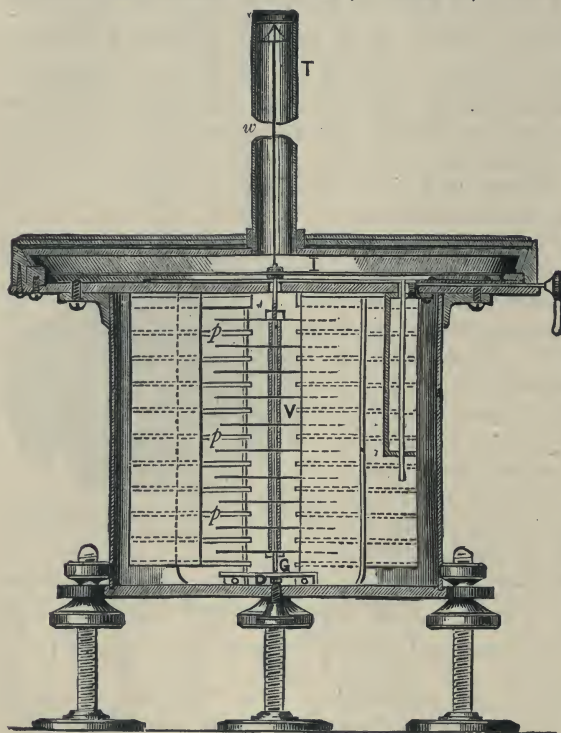

Fig. 757.—Section of Kelvin's Multicellular Electrostatic Voltmeter.

connected, an alternate P. D. be applied to the terminals, the electrostatic forces will tend to rotate the needle always in the same direction.

When, however, the above is applied with pressures of the order of 100 volts to an ordinary quadrant electrometer (Fig. 348), it is found that the deflection produced is either altogether inappreciable, or is far too small to be of any value for purposes of exact measurement. The reason is not far to seek, for when the instrument is used heterostatically in the ordinary way the potential of the needle is usually many thousands of volts, and

therefore  $\left( N - \frac{A + B}{2} \right)$  is very many times  $(A - B)$ . But when  $N = A$  this term becomes  $\frac{A - B}{2}$ , and therefore, although  $A - B$  may now be 100 volts instead of 1 or 2, the deflecting torque  $T$  is very much less than it was before. It therefore becomes necessary to find means of increasing the sensitiveness if the instrument is to be used for the measurement of the ordinary alternate P. D. used on modern electric light and power circuits.

Lord Kelvin, who first gave us the quadrant electrometer, has solved the problem in more ways than one. We shall only describe here the



instrument best adapted for laboratory work, leaving to the technical sections those instruments which, with others, have been designed for use in central stations or for general engineering work.

The laboratory instrument is known as the *Multicellular Voltmeter*; it is shown in section in Fig. 757 and in plan in Fig. 758. It consists, as its name implies, of many cells, which are formed by multiplying the number of quadrants and needles with the object of increasing the deflecting torque. The instrument, however, differs in many other respects from the original quadrant electrometer. In the first place,

the pair of quadrants which would be connected to the needle for alternate P. D. work is abolished, and instead we have two vertical plates *g g*, seen in section in Fig. 758. The shape of the remaining "quadrants" is changed to rectangular (or in some cases triangular) plates *c c* (Fig. 758), eleven pairs of which (*ppp*, Fig. 757, *c c*, Fig. 758) are placed in a horizontal position vertically above one another so as to form ten "cells," within which ten vanes

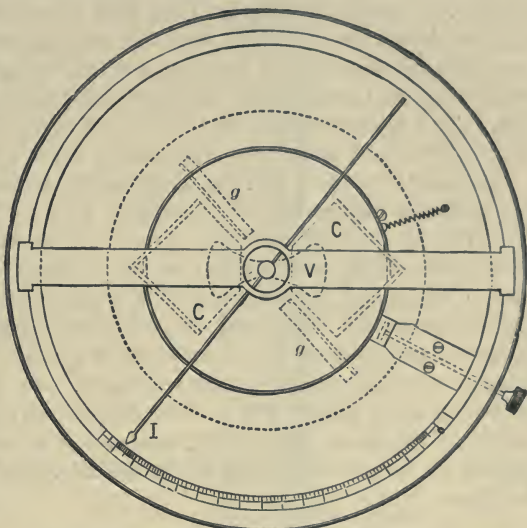

Fig. 758.—Plan of Kelvin's Multicellular Electrostatic Voltmeter.

ten vanes and their spindle replace the so-called "needle" of the older instrument. The spindle carries at its top end a light aluminium pointer *I*, one end of which moves over a scale on which are marked the volts corresponding to the various deflections. The whole spindle, etc., is suspended by a fine iridio-platinum torsion wire *w*, which passes up through the brass tube *T* to a torsion head at the top of the tube by which the zero can be adjusted. A buffer of fine wire shaped like a coach-spring is interposed between the spindle and the torsion wire to prevent any sudden jar injuring the latter.

The spindle and torsion wire are electrically in contact with the case of the instrument and with the plates *g g*, but the horizontal plates *ppp* are insulated and connected to an insulated terminal.

The two points whose P. D. has to be measured are connected—one to an uninsulated terminal on the case of the instrument, and therefore

to the vanes  $v$  and the guard plates  $g g$ , whilst the other is connected to the insulated terminal and the cellular plates  $c c$ . With no torsion in the suspending wire the pointer  $\iota$  is adjusted to stand at zero, and in this position the vanes  $v$  (Fig. 758) are close to the guard plates  $g g$ , from which they are repelled by the electrostatic force, being on the other hand attracted by the insulated plates  $c c$ . The controlling force is the torsion of the wire  $w$ , which is proportional to the deflection. In whichever direction the potential difference is, the direction of movement of the vanes is therefore the same; and it is not changed if the P.D. be reversed in sign. Thus with a periodic and cyclic P.D. of the ordinary kind the deflection is steady so long as the successive loops are the same, for the period of free swing of the suspended apparatus is several seconds at the least, and is therefore many times that of a single alternation. The instrument, as in the case of the electro-dynamometers, etc., measures the *root-mean-square* or *virtual* value of the alternate P.D.

*Hot-wire Voltmeters.*—These instruments, as already described, are also available for measuring an alternate P.D. Their deflections depend upon the heating effect of the current, which is not changed by change of direction, being proportional to the square of the current. They also have a fairly high resistance and a negligible inductance, so that their time-constants are small, and the complications met with in using electromagnetic voltmeters do not arise to the same extent, their impedance being practically equal to their resistance. If, however, they have been calibrated with steady P.D.'s, their deflections must be multiplied by 0.9 to obtain the mean value of the alternate P.D. applied, for the deflections depend on the root-mean-square or virtual value of the P.D., and not on the mean P.D.

#### IV.—WAVE FORM.

No attempt to deal with the subject of the measurement of current and voltage in alternate current circuits would be complete without some detailed reference to the instruments by which it is possible to ascertain directly and quickly the wave-form of the alternations which are being dealt with. The fact that the relations between mean values and R.M.S. values depend upon the wave form has been insisted upon in the preceding pages (*see* pages 766 and 767), and it has been pointed out that the relations there given are only strictly applicable when the wave follows a simple sine curve. But apart from this question of metrical accuracy, there are many problems which confront the practical engineer who is dealing with alternate currents in which the wave form plays an important part. Mention need only be made of the paralleling of dissimilar alternators, the voltage surgings produced in switching currents on and off, the efficiency of trans-

formers, and the still more difficult problems connected with telephone transmission.

The instruments in practical use fall into two main classes: (i) *oscillographs*, or instruments which produce a visible "graph," transient or permanent, of the current or voltage wave at the moment of observation, and (ii) *ondographs*, which by marking down automatically, but much more slowly, the mean values of successive phases sufficiently close together, produce on a travelling band of paper a record of the mean wave form of many successive waves.

The first-named class, "oscillographs,"\* consists of an ingenious modification of the moving coil galvanometer (page 718), which was proposed by Blondel in 1893, and considerably developed, especially by Duddell in subsequent years. The form described below is one of Duddell's, as manufactured by the Cambridge Scientific Instrument Company.

It has been already pointed out that the chief difficulty in using the ordinary galvanometer, whether moving coil or moving magnet, for alternate currents, lies in the fact that the period of oscillation of the moving part being one or more seconds, this moving part cannot respond with sufficient quickness to changes which pass through all their phases in  $\frac{1}{25}$ th or less of a second. The mechanical conditions which must be fulfilled to secure the necessary quickness of response are well known, but are difficult to apply, as the natural period of oscillation of the moving part must be brought down to something of the order of a fraction of  $\frac{1}{1000}$ th of a second if the problem is to be solved. Turning for a solution to other branches of

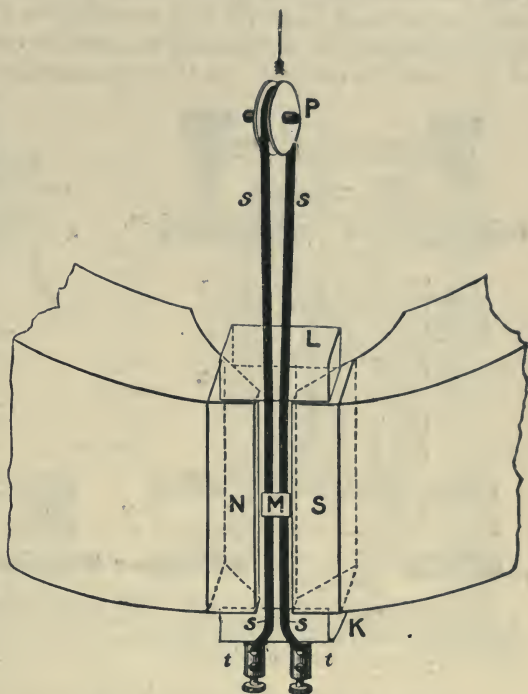

Fig. 759.—Principle of the Vibrator of an Oscillograph.

\* The correct spelling is that given above, and not "oscillographs," as usually written.



physics, M. Blondel noticed that a stretched violin string fulfilled the necessary mechanical conditions. Tuned up to a sufficiently high note, its period of free oscillation can be made a very small fraction of a second, and since its material may be metal it satisfies the electrical condition of being capable of carrying an electric current. In the experiment described on page 592 it is shown (Fig. 563) that a stretched current-carrying wire traversing a fixed magnetic field is subjected to a force proportional to the magnitude of the current and changes its direction when the direction of the current is changed. In this experiment we have the electrical prin-

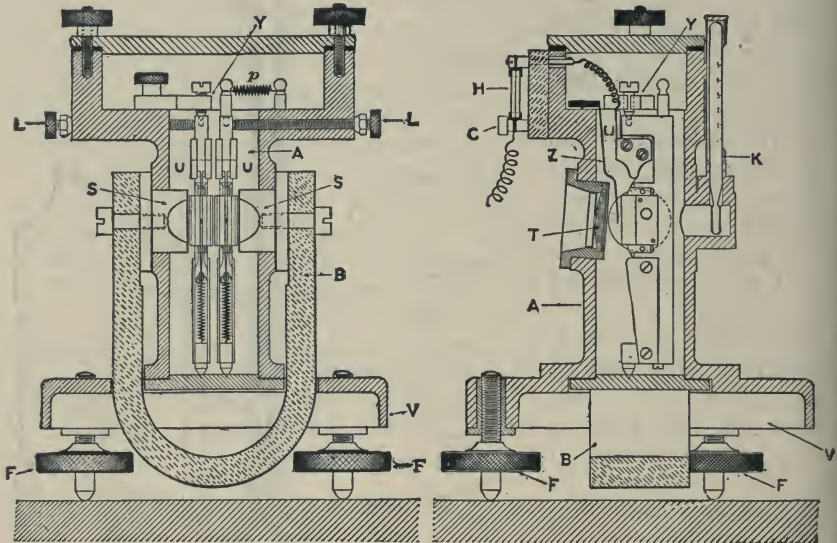

Fig. 760.—Section, Parallel to Front.

Fig. 761.—Section, Front to Back.

The Duddell Permanent Magnet Oscillagraph (Sections).

ciple of the Blondel oscillagraph, inasmuch as the middle point of such a wire, if stretched sufficiently taut, will, when traversed by an alternate current, occupy at each instant a horizontal position whose distance from its position of rest will depend upon the current both in magnitude and direction. How such positions are to be made visible or recorded is an optical problem which will be taken later, after describing the details of the electrical parts of the instruments.

In Fig 759, which should be compared with Fig. 563, is shown the application of the general principle referred to above, together with the first stage of the solution of the optical problem. The current-carrying conductor *sssss* attached to the terminals *tt'* is looped over the ivory

pulley P, by which it can be stretched taut by means of a spiral spring, or otherwise, in its two passages up and down through the narrow gap between the pole pieces N and S of a powerful magnet. When a current is passed from  $t$  to  $t'$  through this conductor, the wire on the left, up which the current passes, will be pushed backwards, whereas the wire on the right, which is carrying the downward current, will be moved forwards. The little mirror M, which is cemented to *both* wires, will thereby be rotated round a vertical axis so that a beam of light falling upon it will be deflected from right to left. If the displacements of the wires are, as they should be, strictly proportional to the magnitude of the current, the deflection of the beam will be a measure of the magnitude of the current, and will be reversed if the current be reversed. In some of the actual instruments the loop has a natural period of vibration of  $\frac{1}{10000}$ th of a second and, therefore, the response to the variations of a current of 100 or 200  $\sim$  is practically instantaneous; as the natural vibrations of the wire (to its own period of oscillation) are damped by immersion in an oil bath, the action is practically "dead-beat" (see page 721).

The displacement of the wire for a given current depends not only on the current, but also on the strength of the magnetic field through which it passes. For sensitiveness, therefore, the field in the gap should be made as great as possible. It may be set up by either a permanent or an electro-magnet, the former being the simpler method, but the latter giving the more intense field. In Figs. 760 and 761 are shown two

sections through the centre of the oil bath of a permanent magnet instrument, one section (Fig. 760) being taken parallel to the front and the other (Fig. 761) from front to back. In Fig. 762 is given on a larger scale a side and front view of the "vibrator," as the stretched wire part of the instrument is called, and in the lower part of this figure there is a horizontal section showing the auxiliary poles by which the field is concentrated in the neighbourhood of the vibrating wires. The same reference letters are used in the three figures.

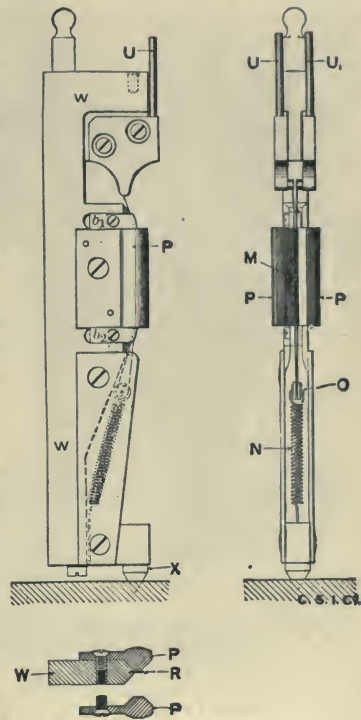

Fig. 762.—Oscillograph Vibrator.

It will be noticed (Fig. 760) that there are two "vibrators" side by side, this being a feature of all the Duddell instruments; the intention is to enable the experimenter simultaneously to compare two different quantities, such as voltage and current, and observe their phase and other differences. The method of connecting the vibrators to the electric currents is explained later. The design of the instrument allows either or both vibrators to be removed quickly and replaced by others in the event of an accident or any other reason rendering it necessary. The vibrators

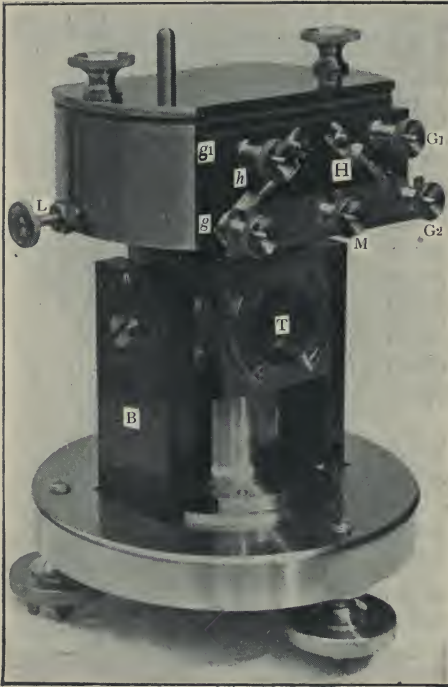

Fig. 763.—The Duddell Permanent Magnet Oscilligraph.

rest on the base *v*, which also carries the oil bath *A* and the permanent magnet *B* (which is U-shaped), and is itself supported by the three levelling screws *F F F*. The mechanical arrangements at the top are designed so that the position of the vibrators can be very accurately adjusted, they being finally held by the tension of the springs *p* against the ends of the long screws *L L*, which can be set up so as to alter the zero when the instrument is ready for use.

In the vibrator (Fig. 762) the ends of the stretched wires are attached to the blocks (insulated from one another) connected to the terminal wires, *v* and *v*, the whole being supported on a brass frame *w w*. After passing over a guide block *b*, the wires pass down into the magnet gap which lies between the auxiliary soft iron poles *P P*, which are also carried by the frame *w w*, and serve to concentrate the field of the permanent magnet *B* by reducing the air-gap to a minimum. This concentration is still further assisted by the thin soft iron partition *R* which runs down the whole length of the gap, dividing it into two compartments, one for each wire. After passing through these two compartments the wires pass over another guide block *b*, and then loop over the ivory pulley *o*, being kept taut by the spring *n*, the tension of which is adjusted when the wires are first mounted.



This tension varies in the different vibrators from 50 grams to a kilogram. The clearance between the wire and the sides of the gap is very small and in the various Duddell instruments varies from 0.04 to 0.15 mm. (0.0016 to 0.006 inch). Half-way up the gap the partition  $\kappa$  is cut away to enable the mirror  $\mu$  to be attached. This mirror is very small, being in the most sensitive instruments only  $0.3 \times 1.0$  mm. ( $0.01 \times 0.04$  inch); for projection purposes, and in the permanent magnet instruments which are not so sensitive, larger mirrors are used, but even then they are still very small, being only  $0.8 \times 1.5$  mm. ( $0.03 \times 0.06$  inch).

When the vibrator is in position the ends of its wire are connected to external terminals  $G$ , one end first passing through a fuse  $\pi$  consisting of much finer wire than the vibrator wire. This fuse wire is carried in a small glass tube with brass caps at each end; these brass caps fit into clips, so that if a fuse "goes," it can be quickly replaced by another. The temperature of the oil bath is given by a thermometer  $\kappa$ , whose bulb is inserted in it, and light is admitted to the mirrors through a little window  $\tau$  in front, consisting of a plano-convex lens slightly tilted to get rid of troublesome reflections from its own surface. The oil in the oil bath is so chosen that at the working temperature its viscosity is just sufficient to give the requisite amount of "damping" to secure dead-beatness without impeding the free motions of the wires.

The whole instrument is shown in Fig. 763, which should be compared with Figs. 760 and 761, in which the same reference letters are used. Very little additional description is necessary. The terminals of one of the vibrators are  $G$  and  $G_1$ , and the fuse wire  $\pi$  which is interposed between the terminal  $G$  and the wire of the vibrator can be clearly seen. At the other side are the terminals  $g$  and  $g_1$ , with the fuse  $h$  of the other vibrator. The brass strap, which can be seen connecting  $G$  and  $g$  to an additional binding screw  $\mu$ , is for the purpose of bringing one end of each vibrator into contact with the frame of the instrument, thus reducing potential differences within the instrument to those necessary to produce the currents in the vibrators. This is especially important for high-voltage (say, 50,000 volts) work, for which the frame of the instrument is insulated from the earth, and the above connection does not interfere with the insulation of the current.

For such high-voltage work the connections are as shown diagrammatically in Fig. 764, in which  $A$  represents a high-voltage generator and  $s$  its main switches. For working the synchronous motor (*see below*) the primary  $p$  of a transformer is connected across the mains, and the circuit of the synchronous motor is connected to the terminals of its secondary  $s$ . This circuit is thus quite insulated from the high-voltage circuit. The two oscillograph vibrators are indicated by the two loops

marked "current" and "P. D." respectively. One end of each loop is shown connected to the common point M, and the the other through its fuse  $f_1$  or  $f_2$  to the switch  $s_1$  or  $s_2$ , by which connection is made through the various resistances to the rest of the circuit.

For measuring "current" a shunt box  $R_3$  is inserted in one of the mains of the alternator, and the vibrator wire is bridged across this through the resistance  $R_2$ . Both these resistances can be varied;  $R_3$  according to the current in the mains, so that full deflections of the vibrator can be obtained with several main currents varying from 2 to 100 amperes, and  $R_2$  to adjust the sensitiveness of the vibrator.

For measuring "P. D." a large non-inductive resistance  $R_2 + R_5$  is bridged across the mains, and the vibrator wire is bridged through an appropriate

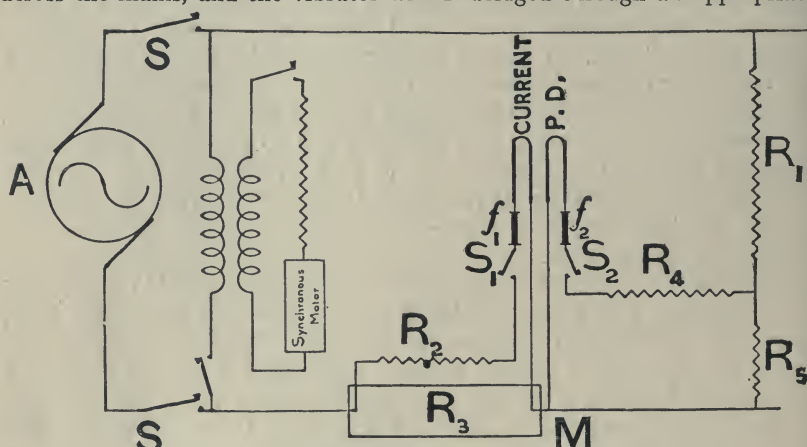

Fig. 764.—Connections of Oscillagraph for High-voltage Circuits.

"tap" across a portion  $R_5$  of this resistance. The resistance  $R_4$ , similar to  $R_2$ , is placed in series with the vibrator wire to allow the sensitiveness to be adjusted.

*Projection.*—If, with the instrument described, a beam of light be passed on to one of the vibrator mirrors when an ordinary alternate current, say of 25  $\sim$ , is traversing its wire, the beam if received on an ordinary galvanometer scale will appear as a horizontal band of light, and all that will be readable will be the length of the band, which will measure the amplitude only of the alternate current (see page 542). To obtain the details of the wave form a motion at right angles to that of the vibrator mirror M must also be available. This can be obtained by allowing a rapidly falling photographic plate to take the place of the galvanometer scale. The plate when developed will then bear a trace of as many com-

plete alternations as its length and rapidity of movement permit. Or the falling plate may be replaced by a kinematograph film, upon which a much longer series of alternations or observations may be recorded. Apparatus for obtaining records by both these methods is supplied by the Cambridge Scientific Instrument Company.

Projection, by which the waves can be made visible to a large audience, is not so easy. The problem has been solved by placing in the path of the beam after reflection from the oscillograph mirrors a mirror oscillating

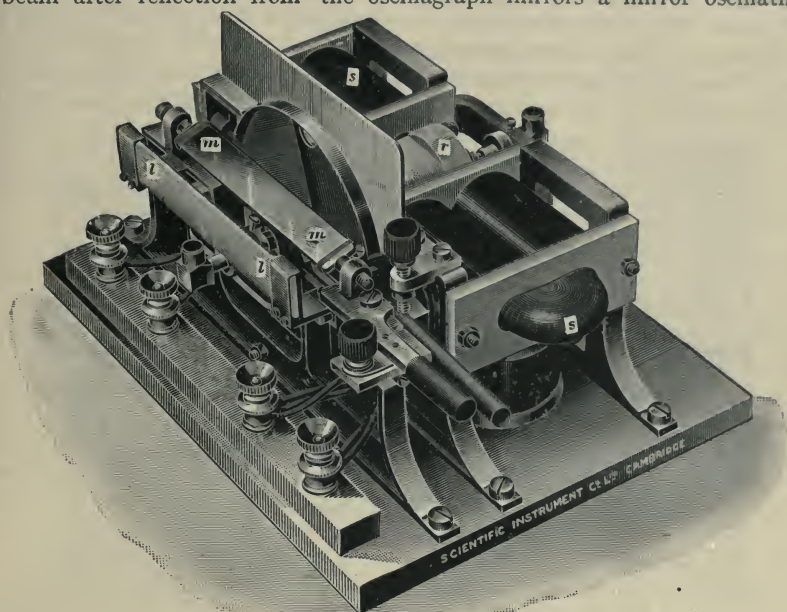

Fig. 765.—Oscillograph Apparatus for projecting the Curves.

synchronously round a horizontal axis. The apparatus is shown in perspective in Fig. 765. The beams of light coming from the oscillograph are received first on the cylindrical condensing lens *ll*, and then pass on to the plane oscillating mirror *m*, from which they are reflected on to a suitable sheet or screen. The mirror *m* is oscillated by a cam driven by a synchronous motor, so that the cam makes one revolution in two complete periods. During one and a half of these two periods the mirror is turned with uniform angular velocity in one direction, and during the remaining half-period it is brought quickly back to its starting position; during this half-period the light is eclipsed by a sector which is interposed in the beam on its way to the oscillograph.



Thus, only the beams received during the one and a half uneclipsed periods reach the screen, and as during these times the mirror *m m* is always moving in the same direction three semi-alternations are projected and appear on the screen. A datum line is given by a mirror in the oscillograph attached to a fixed support between the two vibrators, the fixed beam from which is drawn into a straight band of light by the oscillating mirror *m m*.

The success of the projection depends upon the absolute synchronism between the oscillations of the mirror *m m* and the mirrors *M* in the oscillograph. This is obtained by revolving the cam which moves *m m* by a synchronous motor driven by a current derived from the same source as the currents supplied to the oscillograph. The stator of this motor consists of two horseshoe electro-magnets *s s*, which receive alternate currents

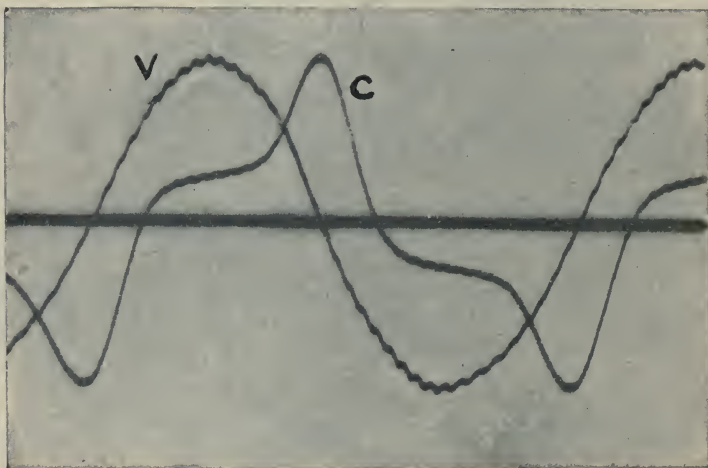

Fig. 766.—Oscillograph Curves showing Voltage and Current Waves.

of the proper periodicity. The rotor *r* consists of an ebonite cylinder carrying on its surface four soft iron armatures fixed parallel to its axis. One armature is attracted up to the poles with each semi-alternation of current in the stator, and thus the ebonite cylinder will run at a speed in revolutions per second equal to half the periodicity. If the cylinder be kept running absolutely at this speed (and as a motor cylinder it can run at no other), the necessary conditions for the oscillation of the mirror *m m* will be satisfied.

*Results.*—As an example of the curves obtainable from an oscillograph, Fig. 766 gives the E.M.F., or voltage wave (*v*) and the current wave (*c*) of a rotary converter which was being driven as an alternator by an independent motor. The alternator was supplying current to a highly

inductive load, which accounts for the large amount of lag (nearly  $45^\circ$ , or one-eighth of a period) of the current behind the voltage. The ripples on the voltage curve are evidently due to the teeth in the armature, and a good guess at the number of the teeth could be made from an inspection of the curve. The curves also illustrate how very different the form of the current curve may be from that of the voltage curve which generates the current.

**Rheographs.**—The above pattern of oscillograph has been described very fully, so that the reader may become acquainted with the chief difficulties—mechanical, electrical, optical and physiological—which have to be faced in designing such instruments. Other solutions of these difficulties have been worked out by M. Blondel and others, but it is obviously impossible to devote equivalent space to their detailed description. Mention can therefore only be made of an ingenious solution by M. Abraham, embodied in an instrument which he calls a *rheograph*, in which the moving part of the instrument is a light aluminium frame which forms the closed secondary of a small transformer within the instrument itself. None but induced currents therefore traverse the moving parts, the actual current or P. D. whose wave form is to be depicted only acting indirectly. The phase displacements due to the various transformations are so manipulated that the reduced currents in the aluminium frame and the angular motion of the frame are practically in step, or what is practically equivalent to being in step, with the function whose wave-form is to be studied. An interesting optical method of projection different from that described above is employed. Electrically, the instrument is subject to certain limitations from which the Blondel and Duddell oscillographs are free; but it is claimed that under most circumstances it gives equally good results.

**Ondographs.**—Unfortunately, it is not possible to find space for a full description of the other type of instrument by which the voltage or current wave form can be automatically traced on a travelling band of paper. It may, however, be explained that the principle employed is that the writing pen is guided by the deflection of a slow-moving galvanometer, which by a revolving commutator is placed in a shunt circuit at different but successive phases of the wave under experiment. The galvanometer is in circuit on one phase of the wave and out of circuit for all other phases for quite a long period compared with the periodic time of the wave, and its deflection at any instant gives the mean of the values of the wave ordinate at that phase for a number of successive alternations. The many experimental difficulties of applying this principle and embodying the results in a practical form of instrument have been successfully overcome. Such instruments, designed by M. Hospitalier, are made by Messrs. Ducretet and Roger, of Paris.

**Analysis of Wave Forms.**—Having obtained a record of the wave-form by one of the foregoing or any other method, it becomes important to examine it carefully, chiefly with a view to ascertaining how far and in what respects it differs from a simple sine wave. Attention has already been drawn (*see* p. 539) to the fact that all cyclic and periodic functions can be expressed as a sum of trigonometrical sines and cosines, in which the time  $t$  is the independent variable, and appropriate constants involving the amplitude, periodicity and phase of the different terms are introduced to adjust the actual magnitudes. Examples were also given (Fig. 514) of wave forms analysed into their constituent sine curves.

In the theory which was subsequently developed, and in most calculations connected with alternate current circuits and machinery, it is assumed that the wave form is the simplest possible—namely, a single sine curve of appropriate amplitude, periodicity, and phase. In actual practice, however, this condition is seldom rigorously satisfied, though in many cases the difference from the sine wave is not great, and the results of this difference are not important. The cases, however, in which the differences lead to results which cannot be neglected, are sufficiently numerous to render it necessary to take some account of the minor constituents of the wave. These minor constituents, which consist of other sine waves superposed upon the first or chief sine wave, are known as *harmonics*. Their periodicity, or periodic time, has usually some simple relation to the periodicity of the fundamental wave, and according as the periodicity of the harmonic is two, three, four, etc., times that of the fundamental, it is known as the *second harmonic*, *third harmonic*, *fourth harmonic*, etc. In alternate current work, on account of the method of generation, the harmonics met with are usually of the *odd* order—namely, the third, fifth, seventh, ninth, etc., the even harmonics being absent; and it may happen that one of the harmonics of a high order—the eleventh or fifteenth—may be prominent and the others negligible.

Methods of analysing the curves into their constituent waves have thus a direct practical bearing, as indicating whether or not the ordinary formulæ for impedance, lag, etc., which are based on the assumption of a single sine wave, can be adopted in a particular case. These methods may be (i.) purely arithmetical, in which, having measured a sufficient number of the ordinates of a complete wave, the constants, amplitude, periodicity and phase of the constituent waves can be calculated; or (ii.) instrumental, by using instruments known as harmonic analysers; or (iii.) a combination of (i.) and (ii.). The explanation of these methods would lead us beyond the limits adopted in this book, but readers interested can consult two very lucid articles by Professor J. Perry, which appeared in the *Electrician* newspaper on February 5th, 1892, and June 28th, 1895.



*Form factor.*—Without obtaining the actual harmonics, some of the results of departure from the simple sine wave may be inferred from a knowledge of the *form factor*, which may be obtained experimentally. This factor is defined as the ratio of the *virtual* or *root mean square* value to the mean value (*see* p. 767), or currents.

$$\text{Form factor} = \frac{C_{\text{r.m.s.}}}{C_{\text{mean}}}$$

For a simple sine wave the value will be:—

$$\text{Form factor} = \frac{1}{.900} = 1.111$$

The effect of the presence of higher harmonics is to increase the virtual value as given by the ordinary measuring instruments proportionally more than the mean values, and thus to increase the form factor.

A simple method, used by Mr. A. Campbell, of determining the form factor of a pressure wave is shown diagrammatically in Fig. 767. In this dia-

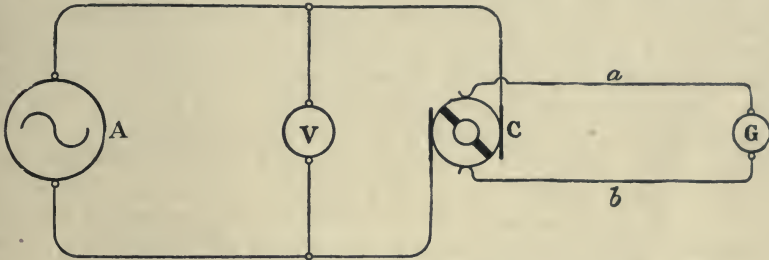

Fig. 767.—Measurement of Form Factor.

gram A is a source of alternate pressure, and c is a revolving commutator driven by a synchronous motor drawing its energy from the same source; G is a high-resistance galvanometer connected to the commutator and acting as a voltmeter; v is an ordinary alternate current voltmeter connected across the mains. The commutator c is a simple commutator, so constructed that the connections between the galvanometer leads a b, and the alternator circuits are reversed twice in a complete period. The consequence is that, when properly adjusted, the currents through G are always in the same direction and are proportional to the volts on its terminals.

The method of experiment is to adjust the commutator until the readings of G are a maximum; these readings will then be proportional to the mean value of the volts, and the voltmeter v will give the virtual value. Hence the form factor, being the ratio between these two values, will be known. If necessary, suitable transformers and resistances may be introduced to adjust the sensitiveness of G and v, care being taken that they do not affect the wave-form.

## V.—MEASUREMENT OF INDUCTANCE.

The preceding pages will have sufficiently impressed upon the reader the importance of the part which inductance plays in most alternate current phenomena and their applications to make it obvious that a knowledge of the numerical value of the inductance is as necessary as a knowledge of the numerical values of the resistance, capacity, or other physical property of the material or circuit under consideration. The principles involved have been already explained; it is now necessary to apply them to purposes of actual measurement.

The inductance ( $L$ ) of a circuit or of a coil has been defined on page 538 as the ratio of the total number of lines ( $N$ ) passing through the circuit, or coil, to the current ( $C$ ) producing them, or in symbols—

$$L = \frac{N}{C} \quad (1)$$

For circuits or coils with no iron or magnetic material in their neighbourhood the ratio of  $N$  to  $C$  is, for all practical purposes, a constant, and therefore  $L$  is a perfectly definite quantity. For electromagnets, and all circuits enclosing iron, the most casual examination of any magnetisation curve—for instance, Fig. 257—will show that this ratio must depend upon the magnitude of the magnetic flux for the particular magnetising current. In order that  $L$  should be constant under such circumstances the **B-H** curve (Fig. 252) would have to be a straight line passing through the origin  $o$ . No magnetic material with which we are acquainted has such a **B-H** curve, and, therefore, in all such cases  $L$ , if defined as above, cannot be constant. Another way of defining  $L$  would be as the ratio of the small increase ( $dN$ ) of lines to the small increase ( $dC$ ) of current which produces them, or in symbols—

$$L = \frac{dN}{dC} \quad (2)$$

This ratio would depend upon the angle of *slope* of the magnetisation curve at the point under consideration, and would, therefore, have a different value at different points on the hysteresis loop.

It would be difficult in practice to introduce into the calculations inductance defined as in (2) and, therefore, as a compromise, it is usual to measure either directly or indirectly the ratio of  $N$  to  $C$  for the particular degree of magnetisation which is being used, thus adopting the definition in (1), with, however, a clear perception that this ratio may change materially for a different value of the actual or the maximum magnetic flux.

The direct measurement of  $C$ , of course, offers no difficulty, but the direct measurement of  $N$  is not an easy matter, though instruments known

as fluxmeters have been devised for the purpose. Indirect methods are, therefore, usually employed, and some of these will now be described.

**Ammeter and Voltmeter Method.**—The simplest method where alternate currents are available is that corresponding to the ammeter and voltmeter method (*see* page 749) of measuring low resistances. An alternator, or alternate current generator *G* (Fig. 768), supplies the necessary current to the electromagnet *M* whose inductance is to be measured. The r.m.s. current is measured by the ammeter *A<sub>v</sub>*, and the alternate p. d. between the terminals *a b* of the electromagnet is measured by the voltmeter *v<sub>v</sub>*. The ratio of the two gives the effective impedance (*I*) of the electromagnet for the particular current used. This impedance is connected with the inductance and ohmic resistance by the equation (*see* page 543)—

$$R^2 + \phi^2 L^2 = I^2 \quad (3)$$

whence,

$$L = \frac{I}{\phi} \sqrt{I^2 - R^2} \quad (4)$$

The method, therefore, requires the resistance of the coil and the periodicity of the testing current to be known. The former can be measured by one of the usual methods; the latter can either be measured with appropriate apparatus or it can be calculated from the observed speed of the generator and the number of its poles. It must be remembered that Equation (3) is only true when the wave form of the testing current follows a simple sine-law. For the reasons given above the values of *L* obtained will depend upon the currents used.

**The Unit of Inductance.**—If the ordinary practical units, volts, amperes, ohms, etc., are used in the above equations, the inductance will be expressed in *henries*, the unit of inductance in the practical electro-

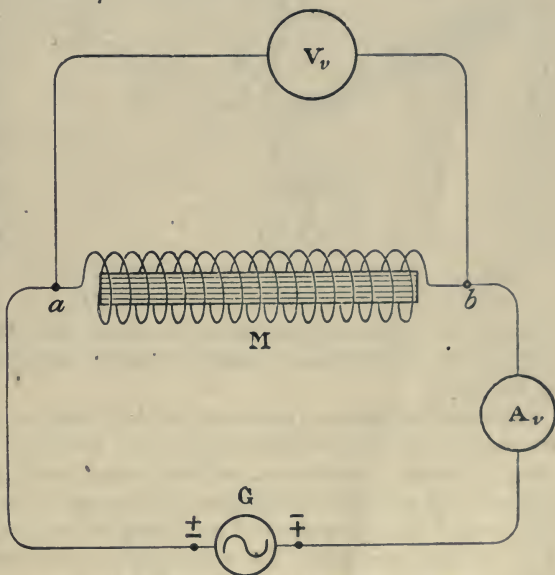

Fig. 768.—Inductance by Ammeter and Voltmeter.



magnetic system having been named the *henry*, in honour of Professor Henry, of Princeton, whose early experiments in inductance will be found described on page 421. For our present purpose the inductance of a circuit in henries may be defined, in accordance with Equation (1), as *the number of lines of force which pass through the circuit when one ampere is flowing round it.*

Another way of looking at the matter is to consider, as on page 538, the back pressure produced in a circuit when the current is rising. This would lead to the definition that *the inductance of a circuit, or coil, is one henry when an inductive pressure of one volt is produced in the circuit or coil by the current changing at the rate of one ampere per second.*

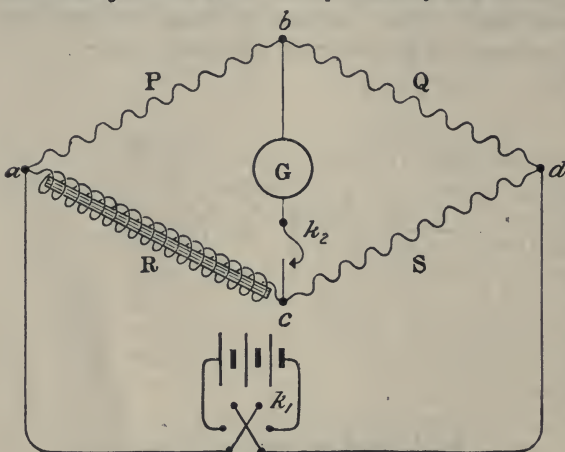

Fig. 769—Rayleigh's Method of Measuring Inductance.

There are other ways of defining the henry, but it need only be further mentioned here that in the electro-magnetic system of units an inductance is a length and, therefore the absolute (c.g.s.) unit of inductance is *one centimetre.* To fit in with the other units of the practical system, the practical unit must be  $10^9$  absolute units, and therefore the henry is  $10^9$  centimetres, or, approximately, the distance from the equator to the pole.

**Bridge Methods.**—Quite a number of methods of measuring inductance are founded upon the magnitude of the inductive effect produced when using transient currents in a Wheatstone's Bridge balanced for steady currents and with the inductance to be measured in one of the arms. The Wheatstone Bridge method of measuring resistance has already been fully described (*see* page 739). The connections are diagrammatically as depicted in Fig. 769, in which R is the resistance to be measured, and P, Q, and S the balancing resistances. For the present purpose the galvanometer G should either be a ballistic galvanometer, or a galvanometer which can be used ballistically (*see* page 722).

The resistances P, Q, and S (*i.e.* the bridge coils) should always be non-inductive; if then the resistance R be inductive (as, for instance, if it

consist of the coils of an electromagnet), balance can only be obtained, as has already been explained (*see* page 741), by closing the battery key  $k$ , before the galvanometer key  $k_2$ . Let such a balance be obtained *very accurately*; that is, so that there is no perceptible movement of the needle of the galvanometer  $G$ . This can be most readily accomplished by shunting the balancing coils  $P$  with a box of coils of much higher resistance, and making the final balance by altering the coils in this shunt box.

With the bridge now balanced for steady currents, it will be found that if the galvanometer key  $k_2$  be closed before the battery key  $k$ , the galvanometer needle will "kick"; that is, there will be a momentary deflection on closing  $k_2$ , after which the needle will return to zero. If now, with the galvanometer key still closed, the key  $k$  be opened, there will be another kick in the opposite direction, but whether equal to or less than the preceding kick will depend upon whether or not the magnetism so far disappears from the electromagnet as to bring it back to the same magnetic state in which it was before the first kick was taken.

The explanation is simple. On closing  $k$ , the current in  $P$  and  $Q$  on the non-inductive side and the potential of the point  $b$  take their final values practically at once. On the other side, however, the inductance of  $R$  retards the growth of the current by the back E. M. F. due to the growing electromagnetism. The consequence is that, although the final potential reached by the point  $c$  will be the same as that reached by the point  $b$ , owing to this retardation it does not reach this potential so quickly, and during this interval  $b$  and  $c$  are not at equal potentials; and a transient current flows from  $b$  to  $c$ , causing a momentary deflection of the galvanometer.

It is obvious that the amount of retardation, and therefore the magnitude of the impulse given to the galvanometer needle, will depend upon the amount of the inductance, or, more accurately, on the time-

constant  $\frac{L}{R}$  of the coil  $R$ . The deflection being a measure of the impulse,

it remains only to make some kind of calibrating experiment to interpret the meaning of the deflection ( $\delta_1$ ) obtained. This can be done by a method suggested by Lord Rayleigh, in which, after observing  $\delta_1$ , the balance for steady currents is disturbed slightly and the steady deflection  $\delta_2$ , due to the disturbance is observed, the galvanometer key being closed, as in ordinary bridge testing, after the battery key, and the battery and everything else remaining unchanged.

To interpret these results it should be noted, first, that the integral effect of the impulse given to the galvanometer will depend upon the total number of lines packed into the coil  $R$  as the current grows from zero to

its final value. This number,  $N$ , by hypothesis, is equal to  $L C$ , where  $C$  is the final value of the current, and we have the proportionality (*see* page 723)—

$$L C \propto \sin \frac{\delta_1}{2} \quad (5)$$

When the bridge is unbalanced for steady currents and the deflection  $\delta_2$  is obtained, this deflection is due to a steady P.D. between  $b$  and  $c$  which may be taken to be equal to  $r C$ , if  $r$  be the amount by which the equal balancing resistance has to be altered to produce  $\delta_2$ . This assumes that the current  $C$  is unchanged by the alteration, which, of course, is only approximately true, but is usually near enough for the difference to be neglected. We therefore have the proportionality—

$$r C \propto \tan \delta_2 \quad (6)$$

The law of the galvanometer is, however, not the same for the two methods of working, and therefore (5) and (6) cannot be combined without introducing a factor depending on these different laws. For a suspended coil galvanometer the result is:—

$$\frac{L C}{r C} = \frac{T}{\pi} \frac{\sin \frac{\delta_1}{2}}{\tan \delta_2} \quad (7)$$

where  $T$  is the periodic time of a complete oscillation of the galvanometer needle, and  $\pi$  is the well-known constant. As the angles of deflection are usually small, it is usual to regard the trigonometrical ratios as proportional to them, in which case the above equation reduces to

$$\frac{L C}{r C} = \frac{T}{2} \frac{\delta_1}{\delta_2} \quad (8)$$

whence,

$$L = \frac{T r \delta_1^2}{2 \pi \delta_2} \quad (9)$$

If damping be allowed for, the last equation becomes—

$$L = \frac{T r \delta_1 \left(1 + \frac{\lambda}{2}\right)}{2 \pi \delta_2} \quad (10)$$

where  $\lambda$  is the logarithmic decrement (*see* page 724).

In actual practice, for reasons which we have not space to dwell upon, it is better to use a reversing key for  $k_1$  instead of a simple make and break. The formula (10) must be modified accordingly.

The above method has been described at some length because it is



the starting-point for several other methods. Its developments must, however, be dealt with more briefly.

Clerk Maxwell, in his epoch-making treatise, pointed out that if a condenser were placed across the arm of the bridge opposite to the inductance, as shown in Fig. 770, it would be possible to obtain a balance for both steady and transient currents. The obvious effect of the condenser in the position indicated is to retard the rise of potential of the point *b* when the key *k*<sub>1</sub> is closed, and to retard its fall when *k* is opened; for energy has to be supplied to charge the condenser, and until it is fully charged the potentials at *b* and *d* do not take their final values. As the inductance

on the closing of *k*<sub>1</sub>, delays the rise of potential at *c*, if only the rises of the potential at *b* and *c* can be arranged to take place at the same rate, these points will always be at the same potential for both transient and steady currents, and the galvanometer will show no deflection if *k*<sub>2</sub> be kept closed while *k* is manipulated. Since the arm *bd* consists of a condenser shunted

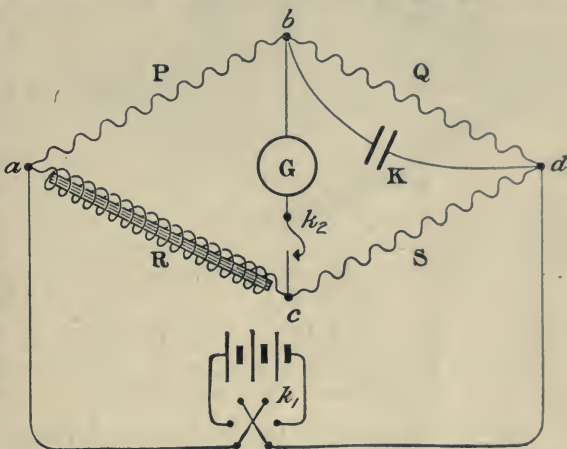

Fig. 770.—Maxwell's Method of Measuring Inductance.

with a resistance and the arm *ac* of an inductance having resistance, the above condition will be fulfilled if the time-constants of the two arms be the same; that is, if:—

$$\frac{L}{R} = QK \tag{11}$$

whence

$$L = QRK = SPK \tag{12}$$

since

$$QR = SP \tag{13}$$

is the condition for balance for steady currents, a balance which must be accurately obtained as in Rayleigh's method.

The great practical objection to the method is that it requires two conditions, (12) and (13), to be simultaneously satisfied. One of these, (13), is easily attained, but the other, (12), is much more difficult with

ordinary laboratory appliances, which, as a rule, do not include a large supply of adjustable condensers. Dr. Sumpner therefore proposed that, balance having been obtained for steady currents, a first throw ( $\delta_1$ ) should be taken with the inductance only in position, as in Rayleigh's method. The known capacity  $x$  was then to be connected across  $b$  and  $d$ , and without attempting to obtain Maxwell's double balance, a second throw ( $\delta_2$ ) was to be observed, the effect of the capacity being to diminish or even reverse

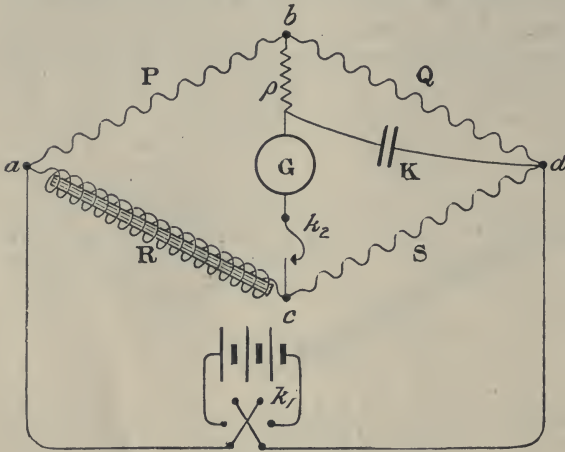

Fig. 771.—Modification of Maxwell's Method.

the earlier throw ( $\delta_1$ ). The value of the inductance can then be calculated as follows:—

$$\delta_1 \propto \frac{L}{R}$$

$$\delta_2 \propto \frac{L}{R} - QK$$

whence

$$\frac{\frac{L}{R} - QK}{\frac{L}{R}} = \frac{\delta_2}{\delta_1}$$

and finally,

$$L = Q R K \frac{\delta_1}{\delta_1 - \delta_2} \quad (14)$$

Much more recently it has been suggested that Maxwell's double balance can be obtained rapidly if a non-inductive resistance ( $\rho$ ) be inserted in the galvanometer circuit in series with the condenser, as shown in Fig. 771. Provided the value of  $K$  be not sufficient of itself to reverse the throw  $\delta_1$ , obtained with the inductance only in circuit, it will be possible by varying  $\rho$  to obtain the double balance, the value of  $L$  being given by the equation

$$L = K (SP + \rho (R + S)) \quad (15)$$

condition (13) being, of course, simultaneously fulfilled.

In all the above equations it is to be remembered that  $K$  is to be expressed in *farads*, and not in *microfarads* (see page 123). If the known value is in microfarads this must be divided by  $10^6$  when used in these equations. The result will be, if the resistances are in ohms, that the inductance will be obtained in *henries*.

*The Secohmmeter.*—An ingenious modification of Bridge methods for measuring inductances was proposed by Professors Ayrton and Perry many years ago. Without going through all the details of its development, it may be explained that in its present form it consists of two revol-

ing commutators mounted on the same shaft, and usually driven by hand, though it is possible to arrange to drive by an electric motor. One commutator takes the place of the key  $k_1$ , (Fig. 769), and the other the place of the key  $k_2$ . Instead of, however, acting as simple make and break keys, both commutators act as reversing keys. If the battery connections of Fig. 769 were reversed with the key  $k_2$  closed, the galvanometer—the bridge being already balanced for steady currents—would receive a number of impulses following one another rapidly in opposite directions, and there would be no deflection of the galvanometer. If, however, between two successive reversals of the battery, the galvanometer have its terminals reversed, then all the impulses will be in the same direction, and the galvanometer will give a steady deflection depending on the mean value of the impulses, and therefore on the inductance in the arm.

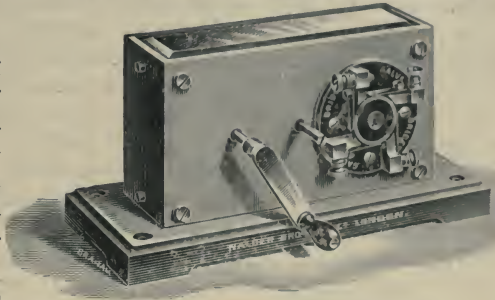

Fig. 772.—Ayrton and Perry's Secohmmeter.

The actual instrument as made by Messrs. Nalder Bros. & Co. is shown

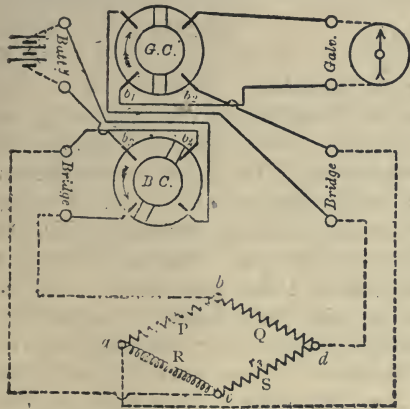

Fig. 773.—The Secohmmeter arranged for Inductance Measurements.

a. arranged to be driven by hand in Fig. 772, and Fig. 773 gives a diagram of the connections. The two commutators are mounted on the same spindle and placed one on either side of the box containing the driving mechanism, which is so geared to rotate the commutators as to give either four or twenty-four reversals for each revolution of the driving handle. Fig. 773 is almost self-explanatory: g.c. is the galvanometer commutator, with two of its opposite brushes joined to the galvanometer, and the other two to the points  $a$  and  $d$  of the bridge.

The other commutator b.c. is the battery commutator, with two of its opposite brushes joined to the battery terminals and the other two to the points  $b$  and  $c$  of the bridge.

If, however, the experiment be made as above, then, although a steady



deflection will be obtained, it is difficult to calibrate the arrangement so as to deduce the actual inductance in henries. It is true that, with the commutator running, the deflection of the galvanometer may be reduced to zero by increasing the resistance on the arm P of the bridge opposed to the arm containing the inductance, and thus what has been sometimes erroneously described as the *spurious resistance* due to inductance can be ascertained. But an inductance in *henries* is not merely a resistance, but a resistance measured in *ohms* multiplied by a time measured in *seconds*; it is, indeed, from this fact that the inventors named the instrument the "sec-ohm-meter" before the name "henry" had been adopted for the unit of inductance. Although, however, we have obtained a resistance which balances the inductance under the conditions of the experiment, we have no measurement of the time-multiplier necessary to convert this resistance into inductance measured in henries.

The arrangement is therefore used to compare an unknown with a known inductance, and for this purpose it is necessary to have standards of inductance, preferably adjustable (*see* page 794), which can be introduced into the arm P of the bridge. Balance being, as usual, very accurately obtained for steady currents, the commutators are run and balance obtained for variable currents by altering the variable standard of inductance. If the bridge is being balanced with equal arms, the two inductances will be equal, but if the arms be unequal, it is the time constants which must be equated, and we have

$$\frac{L_x}{R} = \frac{L_s}{P}$$

whence  $L_x$  can be calculated when  $L_s$  is known.

*Other Bridge Methods.*—The problem of modifying the application of the principles involved in Bridge methods of measuring inductance has attracted a fair amount of attention during recent years, but considerations of space do not permit the results to be described in detail. Passing reference may be made to a series of such methods devised by Mr. A. Campbell, in which the variable standard of mutual inductance described below plays a prominent part. This mutual inductance can be used in various ways to balance the effect of an unknown inductance or capacity.

**The Barretter.**—An ingenious method of measuring small currents of high frequency has been elaborated during the last few years by use of the bolometer, or, as it is now called, the "Barretter." This consists of a conductor of very small mass with a high temperature coefficient, so that when a small continuous or alternate current passes through it its resistance is appreciably altered; any balance depending on this resistance is thereby disturbed, and thus it can be employed to measure inductance. The bolometer itself was used by Langley some twenty years ago in quite a different

manner in a series of most interesting researches. For the construction of the barretter fine platinum wires and other materials have been used, but Dr. Hayes found that a low voltage carbon lamp with a fine filament acted very well, and it is a method based upon this discovery and elaborated by Mr. B. S. Cohen and Mr. G. M. Shepherd in some telephonic researches which will now be described as applied to the measurement of inductance.

The diagrammatic arrangement of the apparatus is shown in Fig. 774, in which the two fine filament carbon lamps marked "Barretter," will be found to be on the circuits of the batteries  $b_1$  and  $b_2$ , respectively, which are closed through the galvanometer  $G$ , the "Inductance Coils" and the "Adjustable Resistances." It will be noticed that the two batteries tend to send currents in opposite directions through the galvanometer, and the adjustable resistances are to be adjusted until the galvanometer shows no current. If, now, small but unequal continuous or alternate currents from any other sources are passed through the barretters, this balance will be destroyed, and can only be restored by bringing the resistance of the barretters back to equality. To complete the equipment of the apparatus, each barretter, *i.e.* each of the carbon lamps, has its poles bridged by a shunt with two 2-microfarad condensers interposed between the lamp and the shunt.

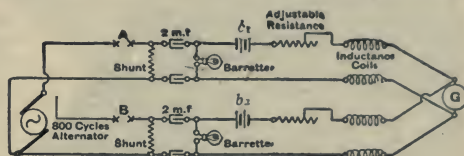

Fig. 774.—Use of the Barretter.

To use the apparatus for the measurement of inductance the opposite ends of the shunts are connected to a sine-wave alternator of high periodicity or some other source of high-frequency currents. In one of the alternator currents the inductance  $B$  to be measured is inserted, and in the other an inductionless resistance  $A$ , which can be adjusted so as to restore the balance if disturbed. These high-frequency currents cannot directly affect the galvanometer, because in the first place the latter is, or may be, only deflected by continuous currents, and also because the high inductance of the inductances near  $G$  effectively choke them off. The alternate currents can, however, easily pass through the barretters, which for them are low-resistance shunts on the galvanometer and its inductances. The barretter filaments are, therefore, heated, and unless the heating effect be the same in each, their resistances will be differently varied, and the batteries  $b_1$  and  $b_2$  will act unequally on the galvanometer, which will, therefore show a deflection. The resistance  $A$  is then to be varied until the balance is restored. When this takes place, it may be assumed that the currents through the two filaments are equal, the voltage impressed upon each circuit by the alternator is the same, and, making proper allow-

ances for the impedances and phase displacements of the various parts of each alternator circuit, it is possible to express the impedance of B, and, therefore, its inductance, in terms of the known resistances, capacities, etc.

The apparatus, as made by Mr. R. W. Paul, is contained in a box (Fig. 775) in which are the two barretters placed side by side so that ordinary atmospheric changes of temperature shall affect each in the same way. In addition the box contains the four inductances, the adjustable resistances for the battery circuits, the condensers and shunts with the adjustable resistance A for the alternate current circuits. The binding screws on the left are for the purposes of making connections to the galvanometer, batteries, alternator, inductance under test, etc.

**Standards of Inductance.**—From the foregoing it will be evident that the determination of the inductances of various kinds of apparatus used

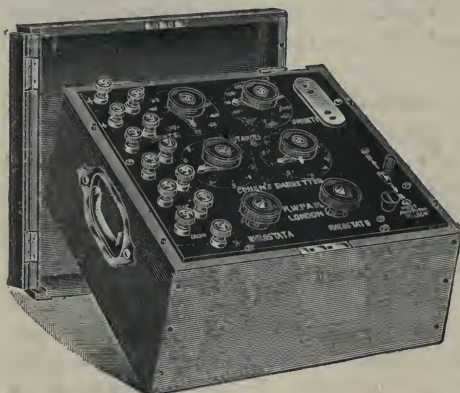

Fig. 775.—Barretter Apparatus.

in alternate and variable current working will be much facilitated if standards of inductance are available in a manner similar to standards of resistances, and if these can be obtained in sufficient numbers and values to deal with the whole range of inductances to be tested. Such standards, as a matter of fact, are available, but not as yet to the same extent and variety as standards of resistance. They fall into two classes: (i.) *adjustable* standards, in which by the movement of

some part of the apparatus the value of the inductance can be varied over a certain range; and (ii.) *fixed* standards, in which each inductance, like each resistance coil, has one definite value which cannot be changed.

**Adjustable Standard Inductances.**—The earliest pattern of a standard inductance of this type was designed by Professors Ayrton and Perry, and is shown in Fig. 776, as now constructed by Messrs. Nalder Bros. and Co. The circuit between the two terminals seen on the front of the baseboard is divided into two parts. One of these consists of well-insulated, double silk-covered, copper wire wound on the movable spherical zone *s*, which is mounted so that it can be rotated round a vertical axis of the sphere of which it forms a part. To realise the shape of this the reader can imagine a hollow terrestrial globe with the temperate and polar portions removed at the two tropical circles and the equatorial belt mounted so as to rotate round one of the diameters of the equator. The other part of the circuit



is wound upon a similar zone of a concentric sphere, this zone being fixed between the upright plates  $\phi_1$  and  $\phi_2$ . The two windings when  $s$  lies also between  $\phi_1$  and  $\phi_2$  are very close together, and the inductance is the mutual inductance of these windings on one another, an inductance the value of which can be calculated mathematically by well-known methods. The mathematical law of the variation of the inductance as the inner coil is rotated is also known, and therefore the value of the inductance for any position of the inner coil, as indicated by the pointer which can be seen on the top dial, can be calculated and marked on that dial.



Fig. 776.—Ayrton and Perry's Adjustable Spherical Standard of Inductance.

One or two points of interest should be noted. In the first place, there is no iron core to either coil, and therefore the value of  $L$  follows the simple definition given in equation (I), page 784, and is the same for all values of the current in the coils. In the second place, there is no metal in the

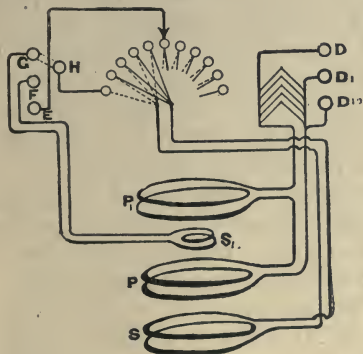

Fig. 777.—Circuits.

Campbell's Adjustable Cylindric Standard of Inductance.

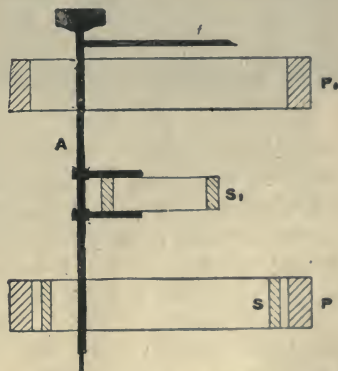

Fig. 778.—Section through Coils.

neighbourhood of the inductive circuits in which eddy currents could be set up, which, by their inductive reaction, would disturb the value of the inductance of the standard. The zones on which the wires are wound are

constructed entirely of wood or ebonite, and are fine specimens of the cabinetmaker's art. The range of the instrument is from about 4 to 40 millihenries.

A standard of inductance consisting of cylindrical coils so placed relatively to one another that their mutual inductance can be mathematically calculated has been designed by Mr. A. Campbell, of the National Physical Laboratory. It is shown diagrammatically in Fig. 777, and in diagrammatic section in Fig. 778. One of the circuits consists of the co-axial coils  $P$  and  $P_1$ , which are such a distance apart that the coil  $s_1$  can be placed between them. The coil  $s_1$  is in another circuit having its terminals at  $G$  and  $F$ , and can be placed in series with, or disconnected from, the coil  $s$ , which is concentric with and within  $P$ . The coil  $s_1$  can be rotated round an eccentric axis  $A$ , its position being indicated by an indicating finger  $F$  moving over a dial, which can be seen better in Fig. 779, which shows the external appearance of the apparatus. By connecting the link shown at  $H$  (Fig. 777) to either  $G$  or  $F$ , the current in  $s_1$  can be made either to assist or to oppose the current in  $s$ , and thus increase the range of the instrument. The coil  $s$  is wound in ten sections, one or more of which can be brought into circuit by a movable contact finger, as shown in Figs. 777 and 779. The coils  $P$  and  $P_1$  are

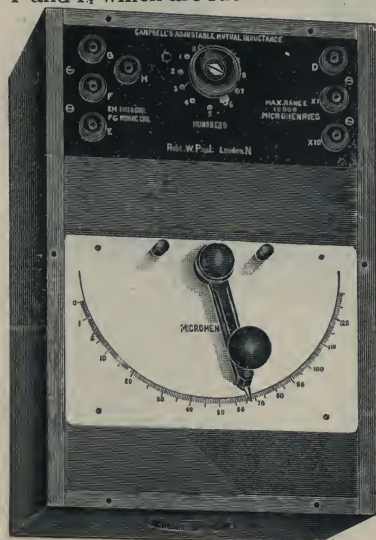

Fig. 779.—Campbell's Adjustable Standard of Inductance.

wound in two sections, one of which has nine times the number of turns of the other, so that when both sections are in series the inductive effect on  $s$  and  $s_1$  is ten times what it is when one section only is used; by bringing out the centre point of each winding to a separate terminal (not shown in the figures), a position of zero inductance can be obtained, using which, the range of the instrument is from zero to 10,000 microhenries or 10 millihenries.

*Non-adjustable or Fixed Standards.*—The disadvantages of the above standards are (i.) that the inductances attainable are comparatively small because of the necessity for making the coils of a size so large that every dimension and the position of each turn can be determined with a high degree of accuracy; and (ii.) the method of construction is necessarily costly if even reasonable accuracy is to be attained.

Standards of inductance of a definite fixed value and of a simple pattern

have, therefore, been constructed. They are coils of insulated copper wire wound with a number of turns as large as possible and without iron or any magnetic or conducting material other than the copper wire in their vicinity. Since the inductance of such a coil depends on the *square* of its number of turns, it is easy to reach higher values than those given above, and single coils having an inductance up to one henry can be obtained at a comparatively small cost. If heavy currents are to be carried or high frequencies used, the wires of the coils should be carefully stranded. The

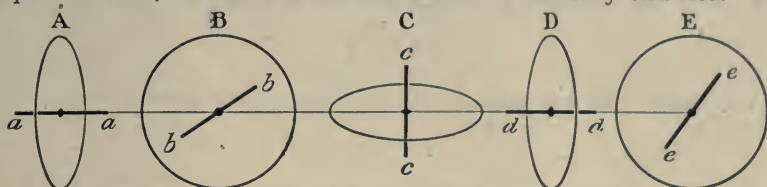

Fig. 780.—Relative positions to secure minimum or no Mutual Inductance.

inductance of such coils cannot be calculated, but must be determined by direct experiment.

If it be desired for convenience to place several such coils in a single box great care must be taken that they are so placed as not to act inductively on one another. To secure this, the magnetic field set up by one coil must not have any lines *looping* through any of the other coils. Unless this condition be satisfied there would be mutual inductance between the coils if used simultaneously in the same test. For instance, if three coils are to be assembled in a box their axes should be mutually at right angles with their centres on the same straight line, as are the axes of the circles A B and c in Fig. 780. If the distance apart be sufficiently great, additional coils, D, E, etc., may be introduced in the same sequence as to the position of their planes, but careful tests should be made to be certain that the condition of no mutual inductance is fulfilled. In Fig. 781 is shown a box made by Messrs. Nalder Bros. and Co., containing four such inductances arranged as A, B, C and D of Fig. 780, and having the values 10, 20, 30 and 40 millihenries. The coils are inserted in the circuit between the two terminal screws by withdrawing the respective plugs exactly in the same way as ordinary resistances.



Fig. 781.—Fixed Standards of Inductance.

#### VI.—MEASUREMENT OF CAPACITY

Various methods of measuring capacity have already been described (*see* pages 757 to 762); there are, however, numerous other methods possible



when alternate currents are available, and, as examples, one or two of these are given here.

**Ammeter and Voltmeter Method.**—The simplest of these consists in measuring the alternate current which passes, when a measured alternate voltage of known periodicity is placed on the terminals of the condenser whose capacity is required. The connections are shown in Fig. 782, and are similar to the corresponding method (*see* page 785) for measuring inductance. To interpret the results, we have (*see* page 547) for sinusoidal currents and with a resistance in series with the condenser, the equation.

$$\frac{V_v}{C_v} = \sqrt{R^2 + \frac{I}{p^2 K^2}}$$

In the present case  $R$  is negligible and the equation becomes

$$\frac{V_v}{C_v} = \frac{I}{pK}$$

or

$$K = \frac{C_v}{pV_v}$$

when  $K$  will be given in *farads* if  $C_v$  and  $V_v$  are in amperes and volts, and  $p$  has the usual value  $2\pi n$  where  $n$  is the periodicity.

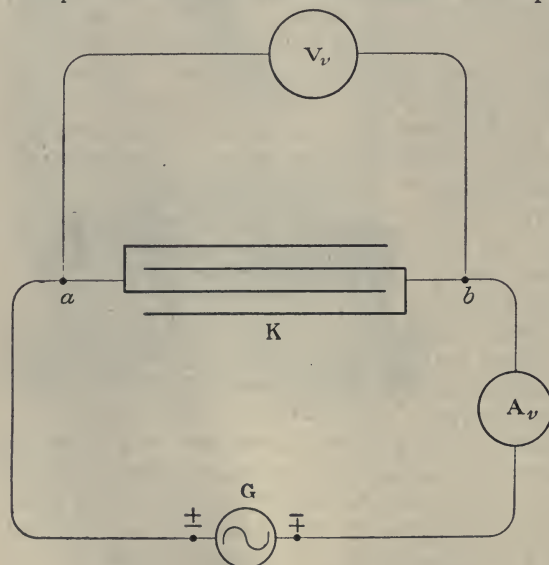

Fig. 782.—Capacity by Ammeter and Voltmeter.

#### Bridge Methods.—

For comparison with a known inductance bridge methods are available, and equations (12) and (15) on pages 789 and 790 may be regarded either as giving the value of the inductance when the capacity is known, or the value of the capacity when the inductance is known.

Two capacities may, however, be directly compared by bridge methods if the bridge be arranged as in Fig. 783. As there is no preliminary balance for steady currents, because such

currents cannot be set up, the key  $\kappa_2$  can be permanently closed, and the balancing consists in adjusting the resistances  $q$  and  $s$  until the galvanometer

G gives no "kick" on the reversal of the key  $K_1$ . When this condition is attained we have—

$$QK_1 = SK_2$$

or

$$K_1 = K_2 \frac{S}{Q}$$

and  $K_1$  will be known if the values of  $K_2$ ,  $S$  and  $Q$  be known. For sensitiveness  $Q$  and  $S$  should be fairly high resistances, as otherwise the impulse communicated to the galvanometer when the balance is far from being perfect will be small.

*Use of the Secohmmeter.*—The above method will obviously be rendered more sensitive by using the secohmmeter, and the diagrammatic arrangement for this purpose is shown in Fig. 784, for which the equation given above will hold when balance is obtained.

The method will be understood from the description already given of the measurement of inductance. (See page 791.)

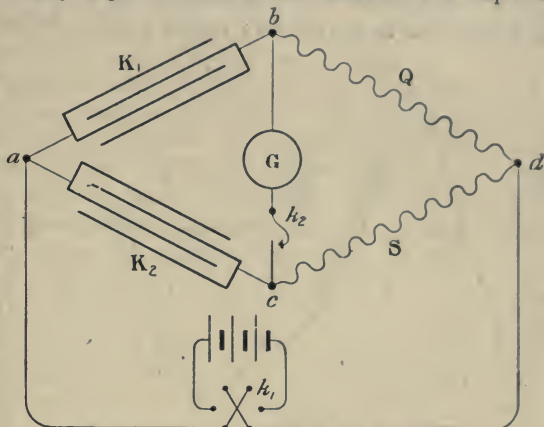

Fig. 783.—Bridge Comparison of Capacities.

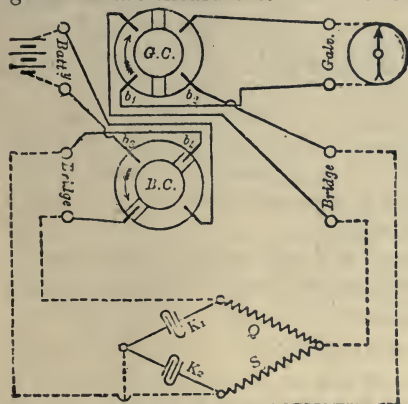

Fig. 784.—The Secohmmeter arranged for Capacity Measurements.

VII.—MEASUREMENT OF POWER

In measuring the electric power in a continuous-current circuit the product of the amperes measured on an amperemeter by the volts measured on a voltmeter will give the power in watts; or the use of two instruments and double readings may be avoided by the use of a wattmeter, which automatically indicates the above product.

In measuring alternate-current power the first method is not available, or rather it requires the determination and use of an additional

factor before the true electrical power can be ascertained by it. The fact that the current and impressed E.M.F. may not be in step with one another

has to be taken into account. An inspection of the curves for current and impressed volts, given in Figs. 516 and 520, shows that whether the current lags or leads the period of a complete alternation of current— $\pi$  to  $\pi$  (Fig. 785)—may be divided into four parts, in two of which the amperes and volts have the same sign, either both  $+$  or both  $-$ , whilst in the other two they are of opposite signs, one being  $+$  and the other  $-$ . Now the product in both the first two cases is  $+$ , which means that power is being given to the circuit; but in both of the last two cases the product

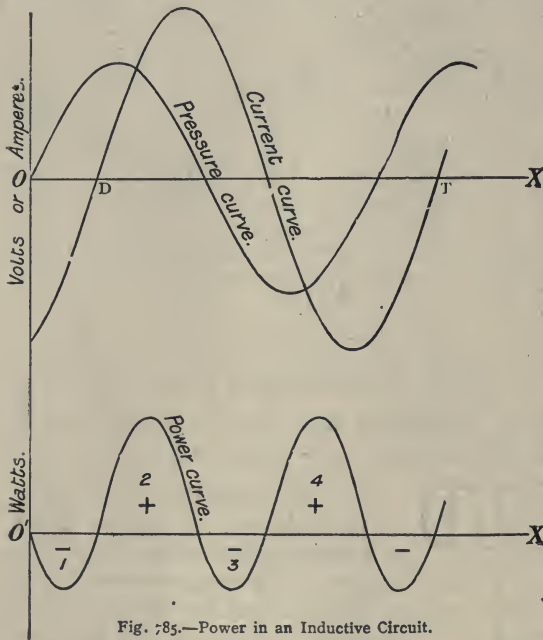

Fig. 785.—Power in an Inductive Circuit.

is  $-$ , which means that power is being given out by, or lost to, the circuit, which during these intervals is driving the generator as a motor. Thus if the products be plotted as in the lower part of the figure we get two large  $+$  loops, 2 and 4, and two small  $-$  loops, 1 and 3. Moreover, the greater the lag or lead the longer and larger do the  $-$  intervals become, whilst the  $+$  intervals are correspondingly shortened and diminished. It is, therefore, quite evident that the amount of lag or lead has a very serious effect on the power developed in the circuit, for the net power must be the difference between the sum of all the  $-$  intervals and the sum of all the  $+$  intervals.

Now the sine-law equations for the E. M. F. and current at any instant, allowing for the difference of phase, may be written (see pages 542 to 548)

$$E = E_0 \sin pt. \quad (1)$$

$$C = c_0 \sin (pt. \pm \lambda) \quad (2)$$

where  $E_0$  and  $c_0$  are the maximum values and  $\lambda$  is the angle of lead ( $+$   $\lambda$ ) or lag ( $-$   $\lambda$ ). The instantaneous value of the power is therefore

$$P = EC = E_0 c_0 \sin pt. \sin (pt. \pm \lambda) \quad (3)$$

and the mean value of the power or the *true watts* will be obtained by



finding the mean value of the last expression. This can be shown to be as follows:—

$$\begin{aligned} \text{Mean power (true watts)} &= \frac{1}{2} E_0 C_0 \text{Cos } \lambda \\ &= \frac{E_0}{\sqrt{2}} \frac{C_0}{\sqrt{2}} \text{Cos } \lambda \\ &= E_{r.m.s.} \times C_{r.m.s.} \times \text{Cos } \lambda \quad (4) \end{aligned}$$

Or the true power can be found by multiplying the readings of an ammeter and a voltmeter which give r.m.s. values, and then further multiplying the product by the cosine of the angle of lead or lag.

As  $\text{Cos } \lambda$  is always a proper fraction, except when  $\lambda = 0$ , when it becomes unity, this last multiplier is always of the nature of a reducing factor, and is usually referred to as the *power-factor*. It becomes smaller and smaller as  $\lambda$  increases, and for large values of  $\lambda$ , approximating to  $90^\circ$ , its effect becomes very serious. For instance, suppose the ammeter reads 100 amperes (r.m.s.) and the voltmeter 200 volts (r.m.s.). If there were no lag the power would be  $100 \times 200 = 20,000$ , or 20 kilowatts. But if the lag be very large (say  $50^\circ$ , or  $\frac{50}{360}$  ths of a full period), then, since  $\text{Cos } \lambda = 0.643$ , the actual power is only  $20 \times 0.643 = 12.86$  kilowatts. Or, putting it otherwise, in order to obtain 20 kilowatts with this amount of lag we should require 155.5 amperes at 200 volts to flow through the circuit. Such a current would produce in a given resistance 2.4 times the heat produced by a current of 100 amperes; hence it is obvious that the amount of lag is a very important factor when a given quantity of power has to be dealt with.

**Wattmeters.**—In order to measure the power in an alternate current circuit as expressed by the right-hand side of equation (4), three instruments would be required, namely, a "voltmeter," an "ammeter," and a "power-factor indicator," and if the power were fluctuating these would have to be read simultaneously. Even in continuous-current circuits where  $\text{Cos } \lambda$  is always = 1, two instruments would be necessary. For both kinds of circuits, therefore, an instrument whose reading depends on the *product* of the *instantaneous* values of the pressure and current in the circuit is the proper instrument to use when only the power has to be measured. Such instruments are called *wattmeters*, and the principles underlying their construction and use have been explained in a previous chapter (see page 379). One of the *electro-dynamometers* there referred to will be found described on page 733 as a current-measuring instrument. With its suspended coil replaced by a fine wire coil of many turns brought into circuit, as shown in Fig. 350, it is an excellent wattmeter. Instead, however, of reconsidering this instrument so modified, it will be more interesting to place on record details of another early pattern of electro-dynamometer wattmeter designed by Mr.

James Swinburne. Fig. 786 shows the outward appearance of this instrument, and Fig. 787 depicts it on a larger scale with the outer case removed. In this instrument there are two fixed coils, one of which is seen in position in Fig. 787, and which carry the whole current of the circuit the power of which is to be measured. These coils, therefore, act as the ammeter section of the instrument. They slide on four brass pins, on which they are clamped in position and placed in connection with the current terminals. The movable coil is quite small, and consists of fine wire wound on a mica cylinder mounted on an ivory spindle which passes through guide holes above and below the coil. The spindle and coil are suspended between

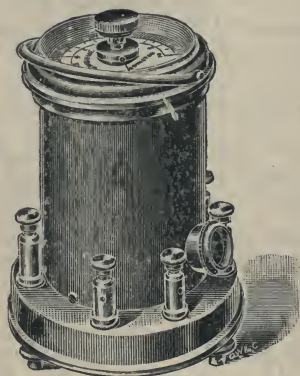

Fig. 786.—Swinburne's Non-Inductive Wattmeter.

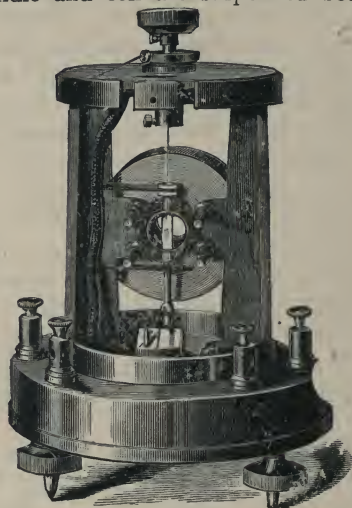

Fig. 787.—Interior of Swinburne's Wattmeter.

two strips of phosphor bronze stretched taut above and below, through which the current is conveyed to and from the movable coil. An index attached to the lower end of the spindle moves to and fro over a fiduciary mark on the bevelled block seen at the lower part of Fig. 787 and which is illuminated by a little window in the case (Fig. 786). The position of this pointer, however, is observed through an opening in the scale plate at the top. The upper end of the top suspending strip is attached to the usual torsion head which carries the pointer which indicates the amount of torsion, or the watts, on the scale.

The fine wire coil is connected, through a large non-inductive resistance carried in the base, to the pressure terminals of the instrument, and therefore carries a current proportional to and practically in phase with, the volts. The torque tending to turn this coil from its zero position at any

instant, is proportional to the product of the currents in the fixed and movable coils at that instant. It is therefore proportional to the instantaneous value of the power, and its mean value during a complete alternation is proportional to the mean watts. This torque is balanced by the torsion of the suspending strip, which is proportional to the angle of torsion as indicated on the scale when the suspended coil has been brought back to zero. This scale can therefore be graduated directly in watts, which will be proportional to the angle of torsion.

When high pressures such as, say, 2,000 volts are being used, additional non-inductive resistances ( $R$ , Fig. 350) of the order of 80,000 ohms are put in series with the fine wire coil. These are usually placed in a separate box. With such high resistances in series with it the time-constant  $L/R$  of the fine wire coil, and therefore the lag of its current, are said to be negligible. Modern examples of alternate-current wattmeters will be described in the technological section.

**Deflectional Wattmeters.**— One practical objection to the forego-

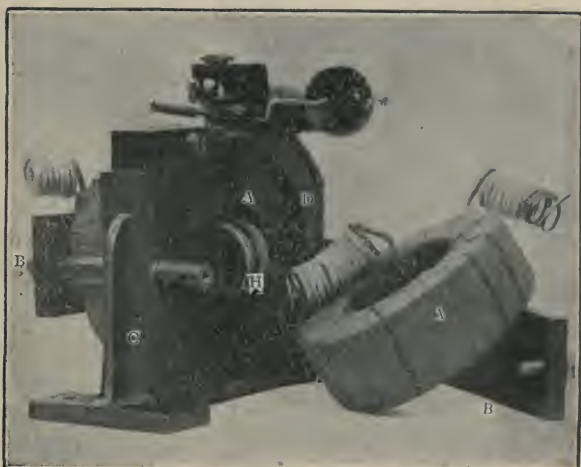

Fig. 788.—Details of E.C. Deflectional Wattmeters.

ing instruments is that they are *fixed-position* instruments, that is their moving parts have to be brought to a fixed position before a reading can be taken. If therefore the power alters whilst the necessary adjustment is being made, the opportunity for taking the reading passes away and may not recur. A demand has therefore arisen for *deflectional instruments*, that is, instruments in which a pointer moving over a scale indicates from moment to moment the power in the circuit. Some of these have many features in common with the instruments just described, and the whole subject of wattmeters from the point of view of the requirements of the engineer is dealt with in Vol. II. It will be of interest, however, to describe briefly here one of the deflectional instruments in connection with the general principles of electrical measurements with which at this stage we are more immediately concerned. For this purpose is selected an instru-



ment constructed by Messrs. Everett, Edgcombe and Co., which is shown partially dissected in Fig. 788 and complete in Fig 789.

The chief points aimed at in the design are (i.) the reduction of eddy currents to a negligible quantity by the elimination of metal as far as possible from the construction ; (ii.) effective air-damping, so that the movements of the moving part shall be dead beat ; (iii.) very small inductance of the pressure coil ; and (iv.) good mechanical design in all parts.

As usual, the fixed coils A A (Fig. 788) carry the main current, and the moving coil H the voltage current. The webbed outer metal frame C is made as light as possible, and of German silver, whose low conductivity still further diminishes any eddy currents which may be

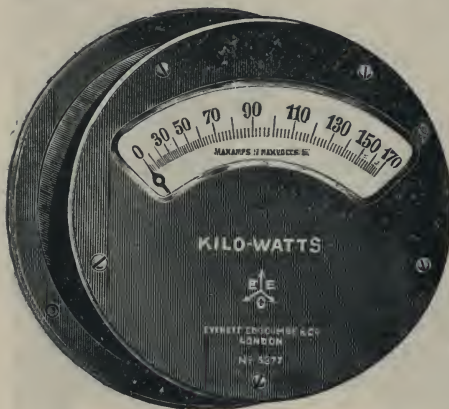

Fig. 789.—E.E.C. Deflectional Wattmeter.

formed. It is lined with insulating material D, and in the hollow space so formed the current coils A A, properly wound and taped, are fixed, being held in their places by the non-conducting strips B B. The moving coil H is wound upon a small and light ebonite former, which is mounted upon the axis, and also carries the pointer and the disc of the damping arrangement, which will be more fully described later in connection with the same firm's ammeters and voltmeters. Its movement is controlled by two spiral springs, which, connected in parallel, convey the current to the moving coil, the other connection being made by a flexible silver strip which practically exerts no torque. The outer case is made of insulating material, which tends to ensure good insulation when the instrument is used on high pressure circuits, and at the same time eliminates eddy currents from this part of it.

Methods of measuring alternate-current power, employing ordinary alternate-current ammeters and voltmeters, which give the root-mean-square value of the quantity measured, have been elaborated by Professor Ayrton. Dr. Sumpner, Dr. Fleming, and others. The connections for one of these methods are shown in Fig. 790. Three Siemens electro-dynamometers used as ammeters are the instruments employed. The object is to measure the power being used in an alternate-current circuit between the points *a* and *b*. To effect this a non-inductive shunt of known resistance *r* is placed across the circuit, the current in this shunt being measured

by an ammeter  $a_2$ . The other two ammeters  $a_1$  and  $a_3$  are placed so that  $a_1$  takes the current in  $a b$  and  $a_3$ , the total current passing through both circuits. Although at every instant the current in  $a_3$  is equal to the sum of the currents in  $a_1$  and  $a_2$ , the readings of the three instruments are not similarly related, and it can be shown mathematically that the power used in  $a b$  is given by the formula

$$P = \frac{r}{2} (A_3^2 - A_1^2 - A_2^2)$$

where  $A_1$ ,  $A_2$ , and  $A_3$  are the readings in amperes of the three instruments, and  $r$  is the value of the non-inductive resistance. A serious practical objection to this and similar methods is that good results are only obtainable when the power absorbed by the non-inductive shunt is comparable with the power used in  $a b$ .

**Polyphase Current Power.**—The above methods have been devised for the measurement of power in single-phase alternate-current circuits, but they may also be used in either of the circuits of a two-phase system. The case of a three-phase system, however, requires a little further consideration. If all that is required is to measure the power in a portion of one of the three conductors, the above methods may be employed. By dealing with each of the conductors separately the whole power may be measured; but this process is more elaborate than is necessary, for it can be shown



Fig. 790.—Measurement of Alternate-Current Power.

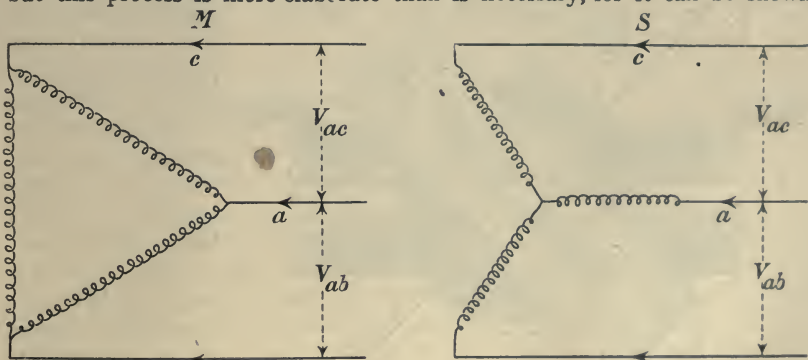

Fig. 791.—Measurement of Power in Three-phase Circuits.

that whether the circuits absorbing the power are mesh- or star-connected, two wattmeters will be sufficient to give the total power used in the three

sections. In Fig. 791, *m* shows the mesh connections for the power-absorbing currents, and *s* shows them star-connected. In both cases let

the currents in the line conductors supplying the power be denoted by *a*, *b* and *c* respectively; let also  $v_{ab}$  denote the P. D. between the lines *a* and *b*, and  $v_{ac}$  the P. D. between the lines *a* and *c*. Then in each of the cases represented it can be shown that the total power absorbed is given by the equation—

$$P = b v_{ab} + c v_{ac}$$

If, therefore, we connect up a suitable wattmeter so that the current *b* passes through its ammeter coil whilst its pressure coil whilst its pressure terminals are connected to the mains *a* and *b*, this instrument will measure the term  $b v_{ab}$ . Similarly another wattmeter will give the term  $c v_{ac}$  if its ammeter coils take the current *c* whilst its pressure terminals are connected to

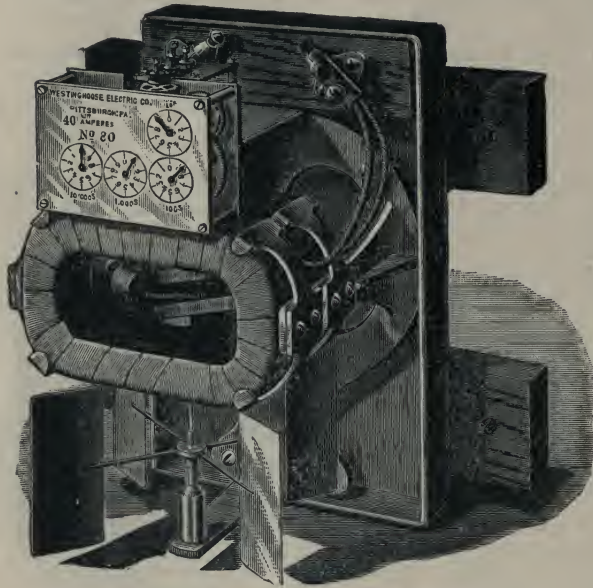

Fig. 792.—Interior of Shallenberger's Meter

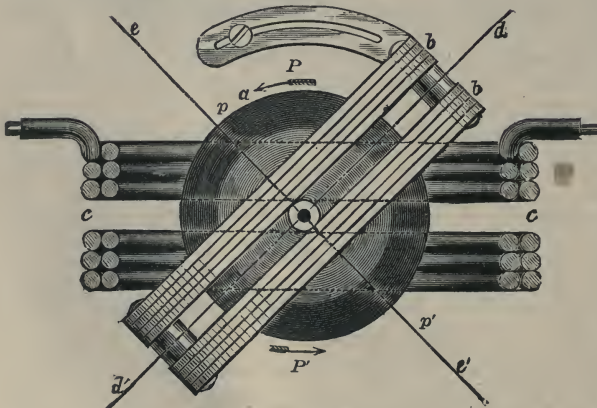

Fig. 793.—Electrical Circuits of Shallenberger's Meter.

mains *a* and *c*. The sum of the readings of the two instruments will give the whole power absorbed by either the mesh-connected conductors at *m* or



the star-connected conductors at *s*. It is possible, however, to combine the two instruments in one so that the deflecting torques shall act upon one vertical spindle and be subjected to a single controlling torque. Such a *double wattmeter* properly connected in circuit will measure at one reading the total polyphase power. If ammeters or voltmeters are used instead of wattmeters, account will have to be taken of phase-differences between pressure and current, for reasons already given. This subject will be taken up again in the technological section.

#### VIII.—MEASUREMENT OF ENERGY

The general principles underlying the measurement of electric energy have already been set forth (page 380 *et seq.*), in connection with the measurement of continuous-current energy. The special additional difficulties which are met with when the energy is in the form of alternate electric currents are in some cases those which we have already considered when dealing with the measurement of alternate electric pressure and alternate electric power.

Thus it follows that both the Aron "Clock-meter" (Fig. 351) and the Elihu Thomson energy meters (Fig. 353) can be used for the measurement of alternate-current energy if the limitations connected with the above special difficulties are not overlooked. What is necessary is that the time-constant of the voltmeter section of the instrument shall be negligible and that, so far as possible, solid masses of metal should be dispensed with in the constructional details, and their places taken by non-conducting material. When this cannot be done the metal should be divided so as to kill such "eddy currents" as would be set up during the use of the instrument.

Meters, however, have been designed which will only operate with alternate currents, and cannot be used on continuous-current circuits. Because of its historical interest we shall describe here an early form of one of these, the Shallenberger meter, which is represented in Figs. 792 and 793. The former shows the complete meter, with the cover removed, and the latter the electric circuits. The meter is in effect a small single-phase induction motor with a counting train and a retarding brake attached. The rotor is a light wrought-iron disc *a* (Fig. 793), carried by a spindle which is very carefully mounted on hardened and polished pivots. The lower end of the spindle carries the light aluminium vanes seen in Fig. 792, which act as a brake, and the upper end carries a worm which engages with the first wheel of the counting train behind the dials at the top. The stator is the coil *c c* through which the alternate currents of the main circuit are passed. The rotating field is produced by the interaction of the currents in this coil, and the induced currents in a short-circuited coil *b b*, so placed

that the magnetic flux from  $c c$  passes through it. It is interesting to note that this device of a short-circuited coil suitably placed on the stator has been revived in some modern types of single-phase induction motors. That such an arrangement will produce a rotating field is obvious when we remember that the E.M.F.'s in the coil  $b b$  will lag a quarter phase behind the currents in  $c c$ , and that the currents in  $b b$  will lag a little behind the E.M.F.'s because of the inductance of this circuit. Thus the necessary phase differences are established, and the rotating field will result, as already explained. The action of this rotating field on a rotor of continuous metal has already been explained (see page 616). The coil  $b b$  can be clamped in various positions, and is adjusted until a known current in the coils gives the required number of revolutions of the spindle per minute.

In this meter the turning torque is proportional to the square of the current, and, therefore, as the speed of rotation must vary directly as the current, it is necessary that the friction brake should set up a retarding torque proportional to the square of the speed. When in use, the meter shown in Fig. 792 is covered by a close fitting case, and the aluminium vanes churn the air in the confined space in the lower part of this case, thus setting up the required retarding torque.

Since the readings of this instrument depend only on the values of the current, and are not affected by the voltage, it is a coulombmeter and not an energy meter. The differences between the two classes of instruments were explained on page 383.

The methods of connecting energy meters to the circuits are the same for single-phase alternate currents as for continuous currents—that is, the full current is passed through the thick wire coils, and the pressure terminals are connected to two points of the circuit between which the full P. D. is maintained. For triphase electric currents two meters may be used, connected to the circuits in the manner described on page 806 for the connection of two wattmeters. To show that the method is correct it should be remembered that energy is = power  $\times$  time. The equation previously given for the wattmeters may therefore be written, as an energy equation, thus:—

$$\text{Energy} = b v_{ab} t + c v_{ac} t$$

where  $t$  is the time during which the energy is being supplied at a constant rate. The connections for currents and pressures are therefore the same as before, and the instruments can be calibrated to record the energy supplied either in Board of Trade or any other convenient units.

The electrolytic coulombmeters at first sight are not adapted for the measurement of alternate currents; nevertheless such a coulombmeter, known as the Lowrie Hall meter, was ingeniously devised in the early days of electric lighting with alternate currents.

Other meters have been designed and constructed which can only be used on alternate-current circuits, and are not available for continuous-current working. It, however, will be most convenient to postpone the description and explanation of the action of these meters, and of more modern ones of all kinds, to the more technical section of the book.

#### IX.—MEASUREMENT OF POWER-FACTORS

Another quantity, the direct measurement of which cannot fail to be of interest to those whose chief work has been with continuous current circuits, is the mysterious power-factor which plays so important a part in alternate current working. More than one method has been devised for the purpose of measuring it, but space will only allow reference in detail to a single solution of the problem in the form of the power-factor indicator made by Messrs. Everett, Edgcumbe and Co. The external appearance of this instrument is shown in Fig. 793, and the various parts in Fig. 794. Before, however, describing the instrument, it would perhaps be well to explain the principles upon which its working depends.

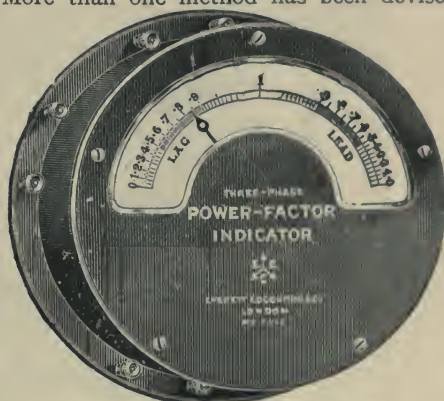

Fig. 793.—E.E.C. Power-factor Indicator.

The main parts of the instrument are similar to those of the same firm's wattmeter (*see* page 803), and consist of fixed coils placed in series with the main current and movable coils which carry a current proportional to the volts. This being a deflectional instrument the various forces called into play regulate the direct deflection of the moving system, and it is this deflection which is read. In this respect and in many mechanical and constructional details it is similar to the deflectional wattmeter described above.

For the simplest case of a monophase circuit the moving coil of the wattmeter is replaced by a system in which there are two coils at right angles to one another wound on the movable frame. Both these are to be pressure coils, practically equivalent to one another and placed in parallel across the mains with series coils in circuit as usual, the difference being that in one case the series coil is non-inductive as in ordinary wattmeter working, and in the other case the series coil is so highly inductive as to cause a lag of the current in its circuit of nearly a quarter phase behind



the impressed P. D. The arrangement is shown diagrammatically and connected to a monophasic circuit in Fig. 795, in which the solenoid *c c* represents the fixed coil carrying the main current, and *a a* and *b b* the two moving coils with their axes at right angles. The coil *a a* is connected across the mains with a non-inductive resistance  $r_1$ , in series with it, whilst the coil *b b* is similarly connected, but has a highly inductive resistance  $r_2$  in its circuit.

For simplicity, assume at first that the circuit of *a a* is quite inductionless, so that the current in it will be absolutely in phase with the P. D. of the mains, and also that the inductance of the *b b* circuit is so high that



Fig. 794.—Details of Power-factor Indicator.

its current practically lags a full quarter period behind the P. D. of the mains. Further assume that the power-factor of the main circuit is unity, that is, that its current and pressure are in step. Then, because of the phase of its current, the coil *b b* on balance will experience no torque, for the  $+$  torque of one quarter period will be exactly balanced by the equal  $-$  torque of the next quarter period; and therefore, since these impulses follow one another very rapidly, the slowly moving coil will remain at rest. On the other hand, the coil *a a*, having its current in step with the current *c c*, will experience full torque, and will set with its axis coinciding with that of the axis of the main solenoid *c c*. The coils will therefore take up the position shown in the diagram, and in this position the attached needle points to the mark "1" on the scale (Fig. 793).

But if the current *c c* is not in step with the P. D. of the mains, *b b*

will experience a resultant torque, since its current is no longer in quadrature with the current in  $c c$ , and the magnitude of this torque will increase with the phase difference—that is, with the power-factor. Simultaneously the resultant torque on  $a a$  will diminish as the power-factor increases. The moving coils will therefore be deflected from the position previously taken up, the direction of the deflection depending upon whether the phase difference in the main circuit is a lag or a lead, and the amount of the deflection depending on the phase difference—that is, on the power-factor. By proper calibration, therefore, the scale of the instrument can be graduated so that the pointer shall indicate the power-factor, and the position for zero power-factor—that is, for an entirely wattless current in the mains—will obviously be at right angles to the position “1” for unit power-factor. The theoretical conditions named cannot be absolutely attained in practice, but they can be approximated to with sufficient

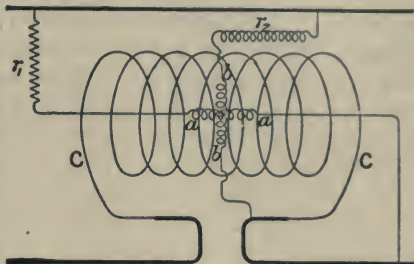

Fig. 795.—Connections of a Monophase Power-factor Indicator.

closeness to make a carefully calibrated instrument reliable over a wide range.

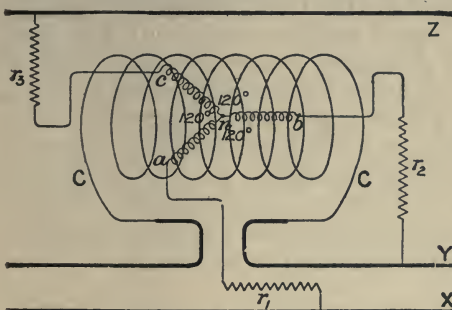

Fig. 796.—Connections of a Power-factor Indicator for Balanced Triphase Circuits.

As in the deflectional wattmeter  $A A$  (Fig. 794) is one of the stationary current coils removed so as to expose the moving coils  $H$  which lie in the large cylindrical hollow formed by the fixed coils when  $A A$  is in its place. The mounting of these moving coils is similar to the mounting of the voltage coils in the wattmeter (see page 804), and many other details are the same. Similar precautions are taken for the suppression of eddy currents, for insulation, etc., etc.

For *polyphase circuits* the problem is somewhat different. The instrument actually shown in Fig. 794 is intended for a balanced triphase circuit, where a single main current coil  $A A$  is put in series in one of the line wires, and the moving system has three coils wound on a spherical insulating frame with their axes  $120^\circ$  apart; two of these coils can be partly seen in the figure. One end of each coil is joined to a common neutral point,

and the other end connected through a large non-inductive resistance to one of the mains. These connections are shown diagrammatically in Fig. 796, where  $c c$  again represent the fixed coil and  $a n$ ,  $b n$ , and  $c n$  the three movable pressure coils,  $x$ ,  $y$ , and  $z$  being the mains.

With unit power-factor the coil  $b n$ , in accordance with the above reasoning, will set along the axis of  $c c$ , and the torques on  $a n$  and  $c n$  will balance. If there be a phase difference, however, between P. D. and current the torques on  $a n$  and  $c n$  will not balance, and the torque on  $b n$  will be weakened. The moving system will therefore be deflected, and will set to a position depending on the power-factor, which therefore may be indicated by the pointer. For unbalanced triphase circuits the current coil  $c c$  is divided into three, one in each phase, placed with their axes  $120^\circ$  apart, and with this arrangement it is claimed that the indications of the instrument are independent of wave-form and periodicity.

#### X.—MAGNETIC MEASUREMENTS

The principles underlying the measurements connected with the determination of the magnetic properties of materials and some of the simpler and fundamental methods used have already been described (*see* Chapter VII., pp. 285 *et seq.*) in an earlier section. The further application of these principles to the development of methods for the rapid determination, in the workshop, of the quantities which are of vital importance to the designer and constructor, may properly be postponed to the technological section. The quantity of most importance to the engineer is the hysteresis loss on cyclic magnetisation (*see* pp. 290 and 295), and its determination under the various conditions which obtain in practice has been the subject of many researches. The permeability of the material and the factors and conditions which influence it are also important, and in their turn have attracted the attention of a great number of investigators. The more important methods and results will be described in due course.

END OF VOLUME I



# INDEX

- A**
- $\alpha$ -rays, 707**  
**Absorption, electric, 225**  
 — in measurement of capacity, 761  
**Acoustic sand figures, production of, 451**  
**Actinic line, 47**  
**Action at a distance, theory of, 24**  
 — of magnets, mutual, 17  
 — of points, 82  
**Ader's telephone, 457**  
 — transmitter, 464  
**Adjustable resistances, 357**  
 — standards of inductance, 795  
**Agglomerate block Leclanché cell, 166**  
**Agonics, 40**  
**Air pumps, mercury, 333**  
 —, sparking distances in, 128  
**Alcohol, electric rectification of, 220**  
**Alioth motor generator, 632**  
 — — —, armature and field coils of, 632  
**Alkali manufacture, application of electricity to, 220**  
**Alkaline earths, Davy's decomposition of, 13**  
 — metals, discovery of, 13  
**Alliance alternator, 555**  
**Alloys, discovery of, by Hensler, Starck, and Haupt, 313**  
 —, magnetic properties of, 310 *et seq.*  
**Alphabet, Morse, 405**  
**Alternate current (A.C.) circuit, effect of inductance in, 541**  
 — — —, effect of permit-tance in, 546  
 — — — magnet, copper ring and, 624, 625  
 — — — measurements, elemen-tary principles, 763  
 — — — motors, mono-phase, 606  
 — — —, rectified, 566  
 — — —, or static, transformers, 433  
 — — — transmission, poly-phase, 580  
 — — —, single-phase, 578
- Alternate currents and alternators, 535**  
 — — —, commuted, 485  
 — — —, connections of loop for, 485  
 — — —, elementary laws of simple, 537  
 — — — in quadrature, 552  
**Alternator, Alliance, 555**  
 —, Ferranti-Thomson, 559  
 —, Gordon's, 562  
 —, Gramme's, 556  
 —, "Mesh" connections of three-phase, 549  
 —, Siemens', 557  
 —, "Star" connections of three-phase, 549  
**Alternators, 554**  
 —, early, 555  
 —, historical notes on, 555  
**Amber, or elektron, 5**  
**Ammeter, Ayrton and Perry's, 349**  
 —, Naldér's, 351  
 — and voltmeter, measure-ment of capacity by, 798  
 — — — method of measure-ment of inductance, 785  
**Ammeters and voltmeters, 348**  
**Ampère, 12**  
**Ampère's molecular currents, 328**  
 — theory of magnetism, 328  
**Ampere, the, the practical unit of electric current, 183**  
**Ampere-turns, '3w of, 281**  
**Analogies to shunts, water, 353**  
**Analogy between water circuit and voltaic circuit, 181**  
**Analysis, electro-chemical, 216**  
 — of wave forms, 782  
**Angle of dip, 38**  
 — of reflection, double, 715  
**Animal electricity, 10**  
 — — —, Walsh, Dr. John, and, 10  
**Anion, 192**  
**Anode, 192**  
**Anti-coherers, 669**  
**Arago's discoveries, 280**  
 — rotations, 422  
 — — —, explanation of, 616  
**Arc, A.C., 20,000 volt, 244**  
 —, Davy's experiments on, 243  
 —, electric, 242  
 — electrodes, shape of, 244  
 —, E.M.F. in the, 256
- Arc lamps, 244**  
 —, length, measurement of, 257  
 —, mercury, the, 270, 673  
 — micrometer, 243  
 —, resistance of the, 255  
 —, Siemens' and Halske's ex-periments with, 244  
 —, striking the, 254  
 —, thermo-electric effects in the, 270  
 —, voltaic, 243  
**Archereau's arc regulator, 245**  
**Arcs, comparison of open and closed, 266**  
 —, enclosed, 264  
 —, flame, 261  
 — — —, inclined carbons for, 262  
 —, hissing, 267  
 —, pure carbon, 262-263  
 —, silent and hissing, effect of, compared, 268  
**Armature, Brush, 494**  
 —, cross-magnetising effect of, 504  
 —, — — — fields of, 505  
 — currents, analysis of mag-netic reaction of, 505  
 — — —, field due to, 503  
 — — —, motor action on, 591  
 —, demagnetising effects of, 504  
 —, — — — fields of, 505  
 —, Ferranti's, 560  
 —, Gramme's, 489  
 — iron in polar gap, 485  
 —, Siemen's cylindrical, 474  
 —, twisted field due to mag-netic reaction of, 503  
 — — — of, shown by iron filings, 504  
 — with commutator on slip rings, 636  
**Armatures, 22**  
 —, drum (*see* Drum armatures)  
 —, open coil (*see* Open coil armatures)  
 —, ring (*see* Ring armatures)  
**Armstrong's steam electric ma-chine, 87**  
**Aron's coulomb-meter, 386**  
 —, Dr., energy meter, 382  
 — vacuum lamp, 673  
**Atlantic cable, the first, 121, 398**

Atlantic cable, the second, 399  
 Atmospheric electricity, 5, 138  
 Atomic weights, definition of, 194  
 Attraction and repulsion, magnetic, 6, 14, 17  
 — of electrical bodies, 6  
 Aurora borealis, the, 141  
 Ayrton and Perry's adjustable spherical standard of inductance, 795  
 — — ammeter, 349  
 — — "magnifying spring" ammeter, 350  
 — — secohmmeter, 791  
 —, Perry, and Sumpner's quadrant electrometer, 376  
 Ayrton's, Mrs., experiments with the arc, 257

## B

**B**, definition of, 285  
 $\beta$ -rays, 708  
 Bachoffner's induction coil, 427  
 Back E.M.F. in a voltmeter, 201  
 — — in the arc, source of, 260  
 — — of a motor, experiment on the, 593  
 Bag, radiograph showing objects in, 697  
 Bain's chemical telegraph, 396  
 Balance, torsion, 24, 62  
 —, current, 734  
 Ball lightning, 140  
 Ball-shaped glow, the, 681  
 Ballistic galvanometers, 723  
 —, Nalder's, 723  
 — method of measuring quantities of electricity, 344  
 — working of galvanometer, 723  
 Barretter, 793  
 — apparatus, 794  
 —, use of, 793  
 Batteries, connecting up, 184  
 — of Leyden jars, 118  
 — —, capacity of, 118  
 —, secondary, 200  
 Battery, Cruikshank's, 149  
 —, experiment with large Planté, 209  
 — induction coils, 427  
 — —, connections of a, 431  
 — —, contact breakers for, 648  
 — —, historical notes, 427  
 —, Wollaston's, 149  
 Becquerel, M. Henry, 706  
 — rays, 706  
 — and Röntgen rays, 710

Behren's electroscope, 55  
 Bell's early experiments with telephone, 444  
 — electric harmonica, 446  
 — telephone, 454  
 — —, diagrams of transmitter and receiver, 454  
 — —, theory of, 455  
 Berliner's microphone, 465  
 — transmitter, 448, 465  
 Beviés, Dr., 8  
 Bichromate bottle cell, 161  
 — cells, 161  
 Bipolar dynamos, 519  
 Blake's microphone, 466  
 Blaserna and electric oscillations, 647  
 Board of Trade standard cell, 365  
 — — unit of energy, definition of the, 381  
 Bodies, glowing or burning, 84  
 —, radio-active, 706  
 Bose, George Mathias, 7  
 Boxes, shunt, 725  
 Boyle, Robert, 2  
 —, law of, 2  
 Breaking a magnet, effects of, 321  
 Bréguet's dial telegraph, 413  
 — receiver, 414  
 —, construction of, 414  
 —, escape wheel of, 414  
 — transmitter, 413  
 Bridge, Kelvin double, 747-749  
 — method of measuring inductance, 786  
 — methods for measurement of capacity, 798  
 —, "Metre," 739  
 Bridges, Wheatstone (*see* Wheatstone bridges)  
 Brush arc lamp, electro-magnet of, 336  
 — light dynamo, 495  
 — —, connections of, 495  
 — armature, 494  
 — discharge in air, 701  
 — dynamo, 496  
 —, development of commutator of, 496  
 — ring, details of core of, 494  
 —, partly wound, 495  
 Bunsen's cell, 160  
 — electrodes, 191

## C

$\gamma$ -rays, 708  
 C-type dynamo, 528  
 Cable, Atlantic, the first, 121, 398  
 —, the second, 399

Cable, capacity of a, 123  
 — telegraphy, 397  
 Calculation of E.M.F., 513  
 Calorimeter, Joule's current, 222  
 —, Lenz's current, 223  
 Campbell's adjustable cylindrical standard of inductance, 795  
 Candles, electric, 249  
 Canton, 7  
 —, pith-ball electrometer of, 10  
 Capacities, bridge comparison of, 799  
 Capacity (*see also* Permittance)  
 —, comparison with a known, 757  
 —, effects of, 545  
 —, measurement of, 757, 797  
 —, absorption in, 761  
 —, by ammeter and voltmeter, 798  
 —, by bridge method, 798  
 —, direct, 761  
 —, secohmmeter arranged for measurement of, 799  
 —, specific inductive, of condensers, definition of, 115  
 —, unit of, 123  
 Carbon, arcs, pure, 262-263  
 — filament lamps, early, 232  
 — —, modern, 233  
 — —, magnified diagram of, 237  
 — microphones, Edison's, 467  
 Cardew's hot-wire voltmeter, 372  
 Carhart-Clark standard cell, 366  
 Cascade, capacity of condensers in, 124  
 —, condensers in, 119  
 Cavendish, 11  
 —, null method of, 11  
 Cell, Faure's secondary, 209  
 Cells in double circuit, 186  
 — in parallel connection, 185  
 — in series, 184  
 — in triple circuit, 186  
 —, secondary, history of, 202  
 —, standard, 364-365  
 Centimetre - gramme - second (c.g.s.) system, 27  
 Change of E.M.F. in loop rotating in uniform field, 484  
 — of medium, influence of, 32  
 Changes of declination, 40  
 —, secular, 43  
 Charge, electric (*see* Electric charge)  
 —, residual, 125  
 — in a condenser, seat of the, 126  
 Charged condenser, energy stored in a, 123  
 Charges of electricity, comparison of, 62  
 Charging by induction, 75, 77, 89

- Charging of electrophorus, lines of force during, 92
- Chart, North Polar, 42
- , South Polar, 43
- Charts, variation, 40
- Characteristic curves of various dynamos, 510
- Chauhnes, Duke de, 8
- Chemical actions in voltmeters, 193
- effect of electric discharge, 133
- of current, 144, 190
- , historical notes, 190
- equivalents, 195
- flame arc, the, 263
- production of the current, 146 *et seq.*
- telegraph, Bain's, 396
- theory, the, 156
- Chladni's experiments, 451
- figures for a square plate, 452
- Chromic acid cells, 161
- Circuit, simple coherer, 669
- , with capacity in series, 545
- Circuits, complex, 187
- , divided, 187
- , water, 187
- , receiving, with decoherer, 669
- , simple, 187
- , polyphase, 552
- time-constant of the, 768 (*note*)
- Circular plates, vibrations of, 451
- Clark cell, standard, 365
- Clarke's dynamo, 473
- Clausius, 127
- on electrolysis, 198
- Clerk Maxwell's theory of light, 661
- Clifton's quadrant electrometer, 376
- Clock diagrams, 540
- for an inductive circuit, 541
- for circuit with permittance, 547
- Coefficient of hysteresis, 296
- Coercive force (*see* Coercive force)
- Coercive force, 20, 297, 299
- , in different materials, 295
- Coherer circuit, simple, 669
- Coherers, 668
- , anti-, 669
- Coil, Faraday's first induction, 417
- magnetising force of a, 281
- of galvanometer, mounting, 719
- Coil, Ruhmkorff, the, 429
- , telephone induction, 433
- Coils, battery induction, 427
- in series, E.M.F.s of four pairs of, 489
- , —, of two pairs of, 488
- , magnetising (*see* Magnetising coils)
- , modern induction, 430
- , resistance (*see* Resistance coils)
- , standard, 357
- , Wheatstone bridge, 741
- Comet, Henry's, 682
- Commutator, conducting coils connected to, 487
- curves, 509
- , revolving, 565
- , short-circuiting brushes on, 610
- , two-part, 484, 566
- , Pixii's, 471
- Compressed air, use of, with influence machine, 108
- Condenser, definition of a, 110
- , discovery of, 11
- , nature of discharge from, 645
- , seat of the charge in a, 126
- Condensers, 109, 113
- , calculation of capacity of, 122
- , combinations of, 124
- , comparison of the capacities of two, 758
- , definition of the capacity of, 115
- in cascade, 119
- on electric machines, 86
- on influence machines, 96
- , ordinary type, 120
- , spherical, 116
- , standard, 120
- , subdivided standard, 122
- , theory of the, 122
- Condensing electroscope, Volta's, 154
- Conducting and non-conducting bodies, 6
- coils connected to commutator, 487
- on ring, 486
- Conductivity, 754
- Conductor, discharging a, process of, 81
- , earthed, under induction, 81
- , effects of points on a, 84
- , prime, 7
- Conductors and insulators, 57
- , electricity, on, 79
- , electrification by contact of, 80
- Conductors, lightning, 9
- , list of, 58
- , partial, list of, 58
- , resistance of, laws of, 184
- , —, of, definition of, 182
- under induction, 74, 75, 76
- , —, lines of force of, 75
- Connecting up batteries, 184
- Connections of a shunt box, ordinary, 725
- of universal shunt box, 727
- to outer circuit, 485
- Conservation of energy, theory of, 151
- Contact breakers (*see* Interrupters)
- for battery induction coils, 648
- , modern, 433
- law, Volta's, 157
- of conductors, electrification by, 80
- theory, the, 154
- experiment, Kelvin's, 155
- Continuous current (c.c.) armatures, 486
- circuits, simple measurements in, 341
- dynamo, elementary theory of, 507
- dynamos, later history of, 518
- , reversibility of, 590
- , connections of loop for, 484
- motors, 590
- transformer (coupled plant), 629
- transmission, 576
- with secondary batteries as transformers, 578
- currents, measurement of small, 712
- , simple, elementary laws of, 180
- electrophori, 94
- Converters, motor, 641
- , diagram of connections of, 642
- , rotary (*see* Rotary converters)
- Cooper-Hewitt lamps with induction coil, 675
- Copper alloy, hysteresis loops of, 315
- , magnetisation curves of, 314
- , permeability curves of, 314
- , electrolytic refining of, 221
- ring and a.c. magnet, 624, 625



- Copper ring, permanent torque exerted on, 625
- Core, definition of, 332
- , laminated. necessity for, 421
- , lamination of, 490
- of brush ring, details of, 494
- "Corkscrew" rules, 276, 280
- Cooke and Wheatstone's five-needle telegraph, 393
- , William Fothergill, 391.
- Coulomb, Charles Augustine de, 11
- , definition of, 341
- meters, 383
- Coulomb's law of electric action, 64
- torsion balance, 25, 62, 63
- Counter E.M.F. in electrolysis, 200
- Couple, or torque, 28
- Coupled motors and dynamos, 628
- Crompton's "Trade" dynamo, 520
- Crooke's researches, 684
- Crossley's transmitter, 464
- Cross-magnetising effect of armature, 504
- fields of armature, 505
- Cross shunts, 353
- "Crown of cups," Volta's, 147
- Cruikshank's battery, 149
- Cuneus, 8
- Curie, M. and Madame, 706
- Current and lines of force, relative directions of, 277
- and torque, relation between, 603
- balances, 734
- , hekto-ampere, 735
- , principles of Lord Kelvin's, 734
- , chemical effect of, 144
- , production of the, 146 *et seq.*
- , conditions for production of, 144
- , direction of circulation of, 332
- , effect of various kinds of, on a tantalum filament, 241
- , electric, the, 143
- , thermal production of, 173
- flow, Ohm's law of, 180
- from two opposing pressures, 487
- induced in a conducting ring by an increasing magnetic flux, 418
- , magnetic effect of, 144, 275
- field of, 277
- measurement, 767
- Current measurement instruments, 767
- on discharge, 81
- , pressure measurement of, 768
- , saturation, 705
- , self-induction of, 423
- , thermal effect of, 144, 222
- Current-carrying conductor, force exerted on, 592
- Currents from Leyden jar and voltaic pile compared, 148
- , generators of three-phase, 549
- , of two-phase, 551
- , induction of, 419
- , of, by motion of coil, 419
- , of, by motion of magnet, 419
- , polyphase, 548
- , pulsating, 536
- Curves, characteristic, 507
- , commutator, 509
- for three-phase currents, 550
- , magnetic (*see* Magnetic curves)
- , magnetisation of different materials, 287
- of permeability (*see* Permeability curves)
- , oscillograph apparatus for projecting, 779
- , showing voltage and current waves, 780
- , sine, 539
- Cyclic changes, 536
- of length on magnetisation, 309
- Cylindrical and plate machines, 7
- D
- Dal Negro's first electric motor, 583
- second electric motor, 584
- Daniell's cell, 170
- Dark space at a negative pole, 683
- , explanation of the, 691
- D'Arsonval's (Maxwell) galvanometer, 718
- Davy, Sir Humphry, 13
- Davy's electric blowpipe, 270
- Dead-beat galvanometers, 721
- Declination, changes of, 40
- lines (*see* Isogonals)
- at North Pole, 1907, 42
- at South Pole, 1907, 43
- magnetic, 15, 37
- , measurement of, 38
- Deflagrator, Hare's, 149
- Deflectional wattmeter, E.E.C., 803-4
- wattmeters, 803
- Deflections, optical magnification of, 712
- Demagnetising effects of armature, 504
- fields of armature, 505
- Density of change and electric force, 82
- of electrification, 61
- Depolarisation, electro-chemical, 170
- Depolarisers, 160
- Deprez's galvanometer, 348
- for large currents, 348
- Development of the primary cell, 158
- Deviation, magnetic, 17
- Dial instruments, 412
- pattern universal shunt box, 728
- resistance box, 359
- , connections of a, 360
- telegraph, Bréguet's, 413
- Diamagnetism and paramagnetic bodies, 301
- experiments, apparatus for, 302
- Diamagnetism, 301
- Diamagnetometer, 303
- Dielectric, 64, 65
- , energy in the, 108
- Difference of potentials on commutator of Gramme machine, 509
- Dip circle, 45
- , Kew pattern, 46
- , magnetic (*see* Inclination, magnetic)
- Discharge, Brush, 701, 702
- by ultra-violet waves, 704
- , chemical effects of, 132
- , electric, 645
- from a condenser, nature of, 645
- , general phenomena connected with, 127
- , heating effects of, 132
- in a high vacuum, action of a magnet on, 683
- in partial and high vacua, 671
- , law of heating effects of, 133
- , luminous effects of, 138
- , magnetic effects of, 137
- , mechanical effects of, 133
- , oscillatory, 98
- , physiological effects of, 137
- , vacuum, effect of a magnet on, 681

- Discharger, Henley's, 128  
 Discharges, high-frequency, 701  
*et seq.*  
 — in higher vacua, 681  
 — in vacuum tubes, magnets affect the, 679  
 —, stratified, 679  
 Discharging a conductor, process of, 81  
 — tongs, 128  
 Discs, luminous, 703  
 Divided circuit, 187  
 — water circuit, 187  
 Dot-and-dash signals, 405  
 Drum armature, 490  
 —, diagram of a, 492  
 —, early form of, 492  
 — winding, 491  
 —, four-coil, 491  
 Drum-wound rotor, 620  
 Dry cells, 167  
 Duboscq's lamps, 247  
 Ducretet's furnace, 272  
 Duddell permanent magnet oscillagraph, 774 *et seq.*  
 Du Fay, 7  
 Dust figures, electric, 11, 135  
 Dyeing, application of electricity to, 220  
 Dynamo, brush, 496  
 — brushes, lead of the, 504  
 —, C-type, 528  
 —, c.c., early history of, 470  
*et seq.*  
 —, —, later history of, 518  
 — construction, elementary principles of, 479  
 —, Crompton's "Trade," 520  
 —, Dr. Hopkinson's improvement on, 498  
 —, early Siemen's, 475, 519  
 —, Edison-Hopkinson, 498, 523-5  
 —, efficiency of a series, 514  
 —, efficiency of a shunt, 515  
 —, electro-magnets, 336, 337  
 —, Faraday's simple disc, 482  
 —, horizontal potentials of, 510  
 —, ideal simple, 483  
 —, "Jumbo," 499  
 —, "Leeds," 528  
 —, magnetic circuits of a four-pole, 532  
 —, — flux in ironclad, 502  
 —, — leakage in early form of, 501  
 —, — "Manchester," 521, 522  
 —, modern Edison two-pole, 526  
 —, potentials with a commutator of a badly designed, 510  
 —, "Phoenix," 527  
 —, power lines of a, 512  
 —, series, 506  
 —, shunt, 507  
 Dynamo, Siemens and Halske internal pole, 533  
 —, source of energy in a, 517  
 —, Victoria, 530, 531  
 Dynamos and motors, coupled, 628  
 —, bipolar, 519  
 —, c.c. reversibility of, 590  
 —, characteristic curves of, 507  
 —, Edison, 521  
 —, graphic diagrams of, 507  
 —, iron-clad, 529  
 —, magnetic circuits of, 499  
 —, — of various, 499  
 —, multipolar, 531  
 —, overtyping, 527  
 —, simple, 483  
 Dyne, definition of the, 27
- E
- Earth, the, a magnet, 18  
 Earthed conductor under induction, 81  
 Edison bamboo lamp, 230  
 — carbon microphones, 467  
 — dynamos, 521  
 — early form of lampholder, 230  
 — effect, 238  
 —, connections for showing, 238  
 —, Fleming's experiment on, 239  
 — electric pen, 600  
 — glow lamp, 230  
 — public supply meter, 384  
 Edison-Hopkinson dynamo, 498, 523-5  
 E.E.C. deflectional wattmeter, 803-4  
 — power factor indicator, 809  
 Efficiency of electric motors, 601, 605  
 — of sources of light, 251  
 Egg, electric, 671  
 Electric Power Storage Company's (e.p.s.) cell, 212  
 Electric absorption, 125  
 — and magnetic circuits, 331  
 — arc, Dr. Fleming's experiments with, 256  
 —, physics of the, 253  
 — spectrum energy curve, 252  
 — blowpipe, Davy's, 270  
 — candles, 249  
 — charge, 54  
 — current, 143  
 — and electrostatic strain lines, 81  
 —, dynamical or magnetic production of, 470 *et seq.*
- Electric current, discovery of influence on magnetic needle, 12  
 — on discharge, 81  
 —, thermal production of, 173  
 — discharge, 645  
 — dust figures, 11, 135  
 — eel, 12  
 — egg, 671  
 — energy, 380  
 — field, 65  
 — force and density of charge, 82  
 — furnaces, 271  
 — hail, 134  
 — induction, 72  
 — leakage, prevention of, 65  
 — light, stratification of, 679  
 — micrometer, 309  
 — motors (*see* Motors, electric)  
 — oscillations, 646  
 — pen, Edison, 600  
 — pendulum, 57  
 — perforation of glass, 134  
 — potential, 110  
 — power, definition of, 377  
 —, measurement of, 377  
 — resistance, 355  
 — sparks, 82  
 — in air, 658  
 — strains, 65  
 — strength, 658  
 — telegraph, 387  
 —, early history, 387  
 — transmission of power, 572  
 — of speech, 450  
 — valve, "Nodon," 559  
 — waves, 660  
 —, polarisation of, 667  
 —, reflexion of, 664  
 —, refraction of, 666  
 — wind, 83  
 — windmill, 83  
 Electrical and mechanical quantities, relation between, 603  
 — attraction and repulsion, 13  
 — discharge, 127  
 — luminosity, 6  
 — machines, 85  
 — measurements, 712  
 — pressure, 362  
 — separation, energy of, 72  
 — stress, 72  
 — shad-fish, 11  
 Electrification, 71, 77  
 — by contact of conductors, 80  
 — distribution of, 60  
 — density of, 61  
 — modes of producing, 61  
 — two kinds of, 7, 55  
 Electricity, atmospheric, 5, 139  
 —, conduction of, through gases, 704  
 —, early history of, 4

- Electricity, generated by combustion, 62  
 — on conductors, 79  
 —, quantity of, 341  
 —, two kinds of, 10  
 Electro-chemical analysis, 216  
 — depolarisation, 170  
 — equivalents, 195-6  
 Electro-chemistry, historical notes, 215  
 Electro-deposition, 217  
 Electro-dyeing, 220  
 Electro-dynamics, theory of, 12  
 Electro-dynamometer, 732  
 —, Siemens', 733  
 Electro-magnet, coil and plunger, 335  
 —, Ferranti's, 561  
 —, Henry's, 332  
 —, ironclad, 334  
 — of a Brush arc lamp, 336  
 — of a Mordey alternator, 338  
 — with "Staggered" poles, 339  
 Electro-magnetic machine, small, Dr. Antonio Pacinotti's description of, 587  
 — theory of light, 661  
 — voltmeters, 370  
 — wattmeter, connections of, 380  
 Electro-magnetism, discovery of, 12, 280  
 Electro-magnets, 330  
 —, dynamo, 336, 337  
 —, early, 281  
 —, long-range, 334  
 —, polarised, 339  
 —, short range, 333  
 —, two-limb, 333  
 —, weight of, 281  
 Electro-metallurgy, 221  
 Electrodes, 192  
 —, arc, shape of, 244  
 —, Bunsen's, 191  
 —, temperature of arc, 254  
 Electrolyte, 191  
 Electrolytic or electric "valve," connections for, 569  
 — rectifiers, 568  
 Electrolysis, Clausius on, 198  
 — defined, 191  
 —, counter E.M.F. in, 200  
 —, explanation of, 198  
 —, Faraday's theory of, 198  
 —, Faraday's nomenclature for, 191  
 —, Grotthus's theory of, 197  
 —, Helmholtz on, 198  
 —, laws of, 194  
 Electrometers, 10, 55, 373  
 —, definition of, 374  
 Electromotive force (*see* E.M.F.)  
 — intensity, 659  
 Electrons, 199, 690  
 Electrophori, continuous, 94  
 Electrophorus, 91  
 —, charging of, 91  
 —, early, 91  
 —, construction of, 11  
 —, modern, 91  
 Electroplating and electrotyping, 217  
 —, apparatus for, 218  
 —, bath, 219  
 Electrotyping, 219  
 —, electroplating and, 217  
 Electro-scope, condensing, Volta's, 154  
 —, gold leaf, 54  
 Electroscopes, 54  
 —, Behren's, 55  
 —, heterostatic, 55  
 Electroscopic powders, 137  
 Electrostatic energy, storage of, 109  
 — strains, experiments on, 66, 67, 68  
 — voltmeter, Kelvin's multicellular, plan of, 771  
 — — — — —, section of, 770  
 — — — — —, voltmeters, 377, 769  
 — — — — —, heterostatically used, 769  
 — — — — —, idiostatically used, 769  
 Electrostatics, 53  
 —, elementary fundamental phenomena of, 53  
 Elements, magnetic, 38  
 —, transmutation of the, 709  
 Elias's electric motor, 586  
 Elwell Parker motor generator, 633  
 Embossing instrument, Morse, 411  
 E.M.F. and P.D., difference between, 364  
 —, back, in the arc, source of, 260  
 —, calculation of, 152, 513  
 — in conductor cutting lines of force, 481  
 —, counter in electrolysis, 200  
 — in the arc, 256  
 —, production of an, by liquids in contact, 158  
 —, production of, 145-6  
 —, simple measurement of, 362  
 —, source of, 259  
 E.M.F.s, comparison of, 363-4  
 — in a single loop, diagram of, 535  
 — of four pairs of coils in series, 489  
 — of two pairs of coils in series, 488  
 Energy, Board of Trade unit of, 381  
 Energy, conservation of, 151  
 — curves, 252-3  
 —, definition of, 381  
 —, electrostatic, storage of, 109  
 — in the dielectric, 108  
 —, loss of, through hysteresis, 295  
 —, measurement of, 381, 807  
 —, mechanical, absorbed by induced currents, 517  
 — meters, 381  
 — —, bob of, 382  
 — of electrical separation, 72  
 — of the magnetic field, 424  
 — produced by radium, 709  
 —, source of, in a dynamo, 517  
 —, transfer and transformation of, 425  
 — transformations, 151  
 Epstein secondary cell, 211  
 Equi-potential lines, 37  
 Equivalents, chemical, 195  
 —, electro-chemical, 195-6  
 Ewing, Professor, discovery of hysteresis by, 291  
 — — — — —, hysteresis curve tracer of, 292  
 Ewing's theory of magnetism, 325  
 External poles, phosphorescence with, 686
- ## F
- Faraday, Michael, 13  
 — effect, the, 317  
 Faraday's electric experiments, 65  
 — first induction coil, 417  
 — ice-pail experiments, 89  
 — laws of electrolysis, 194  
 — simple disc dynamo, 482  
 — theory of electrolysis, 198  
 Faure's secondary cell, 209  
 Feddersen and electric oscillations, 647  
 Ferranti's armature, 560  
 — electro-magnet, 561  
 — transformer, 440  
 Ferranti-Thomson alternator, the, 559  
 — alternator, armature for, 560  
 — — — — —, electro-magnet for, 561  
 Field, electric, the (*see* Electric Field)  
 —, energy of the magnetic, 424  
 —, intensity of magnetic, 27  
 —, — of, shown by lines of force, 35  
 — magnets, 497  
 — — — — —, rotating, diagrams of, 613  
 —, rotating magnetic, copper cylinder placed in, 617



- Fields, magnetisation in strong, 301  
 —, multi-polar rotating, 612  
 —, rotating magnetic, 610 *et seq.*  
 Figures, electric dust, 135  
 Filament lamps, metallic, 239  
 — of glow lamp, materials available for, 228  
 Firefly spectrum energy curve, 253  
 Fisher's modification of Clark's cell, 366  
 Five-needle telegraph, Cooke and Wheatstone's, 392  
 Fixed standards of inductance, 796  
 Flame arc, the, 261  
 —, chemical, 263  
 Flow of water through pipes, 181  
 Flux, magnetic, 283  
 "Focus" tube, 693  
 Foot showing needle, radiograph of, 696  
 Force, coercive (*see* Coercive force)  
 — exerted on a current-carrying conductor placed across a magnetic field, 592  
 —, horizontal, 38  
 —, lines of (*see* Lines of force)  
 —, magneto-motive (*see* Magneto-motive force)  
 Form factor, 783  
 —, measurement of, 783  
 Franklin, 8  
 — kite, 8  
 — lightning conductor, 8  
 — pane, 117  
 Frequency, definition of, 536  
 Frith and Rodgers, experiments of, 256  
 Froment's electric motor, 586  
 Fuller's bichromate cell, 161  
 Furnaces, electric, 271
- G
- "Galileo of magnetism," 3  
 Galvani, Luigi Aloisio, 12  
 Galvani's experiments, 146  
 Galvanometer, astatic, 346  
 —, Ayrton-Mather moving-coil, 719  
 —, ballistic, Nalder's, 723  
 —, —, working of, 723  
 —, D'Arsonval's (Maxwell), 718  
 —, early, 12  
 —, Maxwell's suspended coil, 718  
 —, mounting of coil of, 719  
 —, sensitive, connection of upper and lower coils of, 716
- Galvanometer, sensitive reflecting, 716  
 —, shunting a, 352  
 —, simple reflecting, 717  
 —, speaking, 715  
 —, tangent, 729  
 — with single pivot, Paul's moving-coil, 720-1  
 Galvanometers and galvanoscopes, 345  
 —, ballistic, 723  
 —, dead-beat, 721  
 —, large current, 347  
 —, liquid damping of, 721  
 —, magnetic damping of, 722  
 —, sensitive, 715  
 —, shunting, 352, 725  
 —, standard, 729  
 Galvanoscope, vertical, 346  
 Galvanoscopes and galvanometers, 345  
 Ganz and Co.'s mono-phase motor, 609  
 —, —, —, circuits of, 609  
 Gas batteries, primary, 203  
 — battery, Groves's, 203  
 — check plug, enclosure of arc with, 265  
 — flame spectrum energy curve, 252  
 —, ionisation of a, 704  
 — molecules, return of, 686  
 Gases, conduction of electricity through, 704  
 Gaulard and Gibb's secondary generator, 435  
 Gauss, 29  
 — and Weber's observations, 44  
 — sending apparatus, 390  
 — telegraph, 390  
 Geissler's pump, 234  
 — tubes, 672  
 Generator, c.c., poly-phase motor driving a, 630  
 —, Gramme, early, 518  
 Generators, secondary, 435  
 Giessing, 7  
 Gintl, William, and duplex telegraphy, 397  
 Gilbert, William, discoveries of, 3, 5  
 Gladstone and Tribe on secondary cells, 210  
 Glass, electric perforation of, 134  
 — and oil insulators, 214  
 Globe electric machine, 7  
 Glow, ball-shaped, the, 681  
 — lamp, physics of the, 237  
 —, or incandescent, lamps, 226  
 —, —, —, causes of rapid development of, 228  
 —, repulsion of, by a conductor, 682  
 Glowing or burning bodies, 84
- Gold, extraction of, by electrolytic methods, 221  
 Gordon, Andreas, 7  
 Gordon's (di-phase) alternator, 562, 564  
 Gower telephone, 456  
 — electro-magnet, 340  
 Gower-Bell microphone, 465  
 Gramme alternator, 556  
 — armature, 489  
 — generator, early, 518  
 — ring generating both continuous and alternate currents at same time, 636  
 —, section of a, 480  
 Gray, Stephen, 6  
 Gray's telephone, 447, 458  
 Great Eastern, the, 399  
 Grenet's bichromate cell, 161  
 Griscom's motor, 599  
 Grotthus's theory of electrolysis, 197  
 Groves's cell, 160  
 — gas battery, 203  
 Guericke, Otto von, 5  
 —, electric machine of, 5
- H
- H, definition of, 285  
 H-cadmium cell, modern, 369  
 —, diagram of, 368  
 H-pattern standard cell, 365  
 Hail, electric, 134  
 Hand, radiograph of, 698  
 Hare's deflagator, 149  
 Harmonica, Bell's electric, 446  
 Hartmann's discovery of dip, 2  
 Haupt's discovery of alloys, 313  
 Hawksbee, 6  
 Head, radiograph of living, 698  
 Hekto-ampere current balance, 735  
 Helmholtz on electrolysis, 198  
 Henley's discharger, 128  
 Henry, Professor Joseph, discoveries of, 281  
 —, law of ampere-turns of, 281  
 Henry's comet, 682  
 — electro-magnet, 332  
 Hensler's discovery of alloys, 313  
 Hertz's experiments, 662  
 — oscillator, 663  
 Heterostatic electroscopes, 55  
 Hewitt, Mr. Cooper, 673  
 Hibbert's standard cell, 366  
 High-frequency discharges, 701  
 — *et seq.*  
 High-insulation keys, 759, 760  
 — plug switch, 760  
 High pressure, transformer for, 437

- High resistances, measurement of, 745  
 Higher vacua, discharges in, 681  
 Hissing arc, 267  
 —, explanation of, 269  
 Hittorf, 199  
 Hoffmann's voltameter, 188  
 Holtz influence machine, 93  
 —, action of, 95  
 Horizontal force, 38  
 — intensity, measurement of, 47  
 — surface, weight vibrating on, 646  
 Hot-wire voltmeters, 371, 772  
 —, principle of, 371  
 Hughes's carbon microphones, 449  
 — microphone experiments, 448, 459  
 — microphones without carbon, 449  
 — polarised electro-magnet, 340  
 — telegraph printing instrument, 395  
 — theory of magnetism, 325  
 Hunning's transmitter, 469  
 Hydro-electric machine, 87  
 Hydrogen stratification, 692  
 Hysteresis, 290  
 —, coefficient of, 296  
 — loops for different magnetising forces, 294  
 — for various kinds of iron, 298  
 — of copper alloy, 315  
 —, loss of energy through, 295  
 —, typical loop, 290  
 —, viscous, 297
- I
- Ice-pail experiment, Faraday's, 88  
 —, —, lines of force at stages of, 89  
 Immisch motor, 596  
 —, longitudinal section of, 596  
 —, mechanical connection of core discs to shaft of, 597  
 Impedance, 543, 547  
 —, construction for, 547  
 Incandescent lamp, carbon filament of, 237  
 —, or glow, lamps, 226  
 Inclination, changes of, 47  
 —, measurement of, 44  
 —, or dip, discovery of, 2  
 —, magnetic, 16, 37  
 Induced currents, 418  
 —, direction of, 418  
 —, mechanical energy absorbed by, 517
- Inductance, adjustable standards of, 794  
 — and permittance combined, 547  
 —, bridge method of measuring, 786  
 —, definition of, 538  
 —, effects of, 540  
 —, fixed standards of, 796  
 —, Maxwell's method of measuring, 789  
 —, measurement of, 784  
 —, ammeter and voltmeter method of, 785  
 — of the ring, effect of, 624  
 —, Rayleigh's method of measuring, 786  
 —, relative position of coils to secure minimum or no mutual, 797  
 —, standards of, 794  
 —, the unit of, 785  
 Induction apparatus, Reiss's, 72  
 —, charging by, 75, 77, 88  
 —, coil, battery, 427  
 —, connections of a, 431  
 —, modern, 430  
 —, telephone, 433  
 —, earthed conductor under, 81  
 —, electric, 72  
 —, electrification by, 73  
 —, experiments, 73  
 —, higher orders of, 421  
 — in wires across magnetic poles, 481  
 —, magnetic, 322  
 —, magnetisation by, 19  
 —, magneto-electric, laws of, 420  
 — motor, rotor, stator and other parts of, 621  
 —, plan of mono-phase, 626  
 —, Tesla's split-phase, 627  
 —, Thomson's mono-phase, 626  
 — Westinghouse poly-phase, 623  
 — motors, 610  
 —, alternate current, 610  
 —, mono-phase, 622  
 —, split-phase, 626  
 —, self, 423  
 Inductive circuit, power in, 800  
 Inductivity, 114  
 Inductorium, Ruhmkorff's, 429  
 Influence machines, 88, 93  
 —, use of compressed air with, 108  
 Instruments, measuring, 370  
 —, telegraphic, 407-415  
 Insulated conductors under induction, 74, 75, 76
- Insulation, 759  
 Insulators, conductors and, 57  
 —, glass and oil, 214  
 —, list of, 58  
 Intensity, changes of, 52  
 —, horizontal (*see* Horizontal intensity)  
 —, magnetic (*see* Magnetic intensity)  
 — of electric field, 67  
 — of field shown by lines of force, 35  
 — of magnetic field, 27  
 — of magnetisation, 28  
 Interrupter, Caldwell's modification of Wehnelt's, 655  
 —, contact points in, 650  
 —, D'Arsonval's explanation of action of, 654  
 —, diagram of Tesla's apparatus, 657  
 — driven by an a.c. motor, 651  
 —, mercury jet, 652, 653  
 —, or contact breaker, 650  
 —, Price's modification of Wehnelt's, 656  
 —, Swinton's modification of Wehnelt's, 655  
 —, Tesla high-frequency, 657  
 —, thermal or electrolytic, 653  
 —, Wehnelt, with adjustable electrodes, 656, 657  
 —, Wehnelt's, 654  
 Inverse squares, electric law of, 64  
 —, law of, 11  
 —, magnetic law of, 25  
 Inversion, thermo-electric, 176  
 Ionic velocity, 199  
 Ionisation of a gas, 704  
 Ions, 192  
 —, velocities of the, 199  
 Iron, critical temperature of, 305  
 —, hysteresis loops for various kinds of, 298  
 —, magnetic properties of, 286  
 —, permeability, 289  
 —, curves for, 289  
 —, recalescence of, 306  
 Iron-clad dynamos, 529  
 —, leakage field of, 529  
 —, magnetic circuits of, 529  
 Isoclinics, 47  
 — for 1907, 48  
 Isodynamics, 52  
 — for 1907, 51  
 Isogonals, 40  
 — at the North Pole, 42  
 — at the South Pole, 42  
 — for 1907, 41  
 —, true, for 1886, 45  
 Isogonic lines, 40

## J

- Jablochkoff candle, 249  
 Jackson, Mr. Herbert, 693  
 Jacobi's electric motor, 585  
   — experiments, 216  
 Jamin's compound magnet, 23  
 Jar, electric, or Leyden, 8, 117  
 Johnson and Phillips' squirrel cage rotor, 618  
 Joule, definition of, 381  
 Joule's current calorimeter, 222  
   — law, 222  
   — voltaic cell and circuit experiments, 151  
 "Jumbo" dynamo, 499

## K

- Kathion, 192  
 Kathode, 192  
   — rays, 687  
   — —, Lenard's experiment with, 689  
   — —, shadow cast by, 685  
   — stream deflected by a magnet, 688  
   — streams, mutual repulsion by, 688  
 Kelvin double bridge, 747-749  
 Kelvin's, Lord, quadrant electrometer, 374  
   — multicellular electrostatic voltmeter, 770  
 Kerr effect, the, 318  
   — on electrostatic strain, 66  
 Kerr's experiments, 66  
 Kew magnetometer, 38  
 Key, Morse, 407  
   — reversing, 407  
 Keys, high-insulation, 759, 760  
 Kilowatt hour, the, 382  
 Kinetic, transformers (*see* Transformers, kinetic)  
 Kleist, Dean, 8  
 Kohlrausch, 127  
 Kohlrausch's bridge for measurement of liquid resistances, 743  
   — condenser, 114  
   — torsion electrometer, 373  
 Konn's glow lamp, 227  
 Krizik's bars, 336

## L

- Ladd's dynamo, 477  
 Lady's hand, radiograph of, 696  
 Lag in an inductive circuit, 544  
   — of brushes in a motor, 594  
 Laminated core, necessity for, 421

- Lamination of cores, 490  
 Lamp, mercury vapour, Cooper-Hewitt, 674  
   —, mirror and scale, action of the, 714  
   — stand, with transparent scale and glow lamp, 714  
 Lamps, arc, 244  
   —, glow, or incandescent (*see* Glow lamps)  
 Lane's unit jar, 119  
 Langley's experiments on efficiency of sources of light, 251  
 Lauffen-Frankfort transmission, connections at Lauffen, 580  
   — —, power circuits at Frankfort, 581  
 Lead of the dynamo brushes, 504  
 Leakage, magnetic, 500  
 Leclanché's agglomerate cell, 166  
   — cell, 162  
   — low resistance cell, 166  
 Lenard's experiment with Kathode rays, 689  
 Length, change of, on magnetisation, 306 *et seq.*  
 Lenz's current calorimeter, 223  
   — law, 418  
 Lessing's cell, 169  
 Levy, M., 652  
 Leyden jar, 8, 117  
   — — and voltaic pile, currents from, compared, 148  
   — —, batteries of, 118  
   — —, discharge of, 127  
   — —, oscillatory discharge of, 98  
   — —, unit, 119  
   — —, with movable coatings, 126  
 Lichtenberg's dust figures, 11, 136  
 Lifting power of a magnet, 23  
 Light, efficiency of sources of, 251  
   —, magnetism and, 316  
 Lightning, 139  
   —, ball, 140  
   —, tubes, 139  
 Lines of force and electric charge, 68  
   — —, current and, relative directions of, 277  
   — —, direction of electric, 69  
   — —, direction of magnetic, 34  
   — —, during charging of electrophorus, 92  
   — —, E.M.F. in conductor cutting, 481  
   — —, from charged cylinder, 70  
   — —, intensity of field shown by, 35

- Lines of force, magnetic curves and, 29  
   — —, —, defined, 278  
   — — of a circular loop, 277  
   — — of a uniform field, 480  
   — — round a straight current, 276, 479  
   — —, screening, 34  
   — —, tendency to contract and repel one another sideways, 72  
 Liquid resistances, 741  
   — —, measurement of, 743  
   — —, — by fall of potential, 744  
 Litzendorf, 7  
 Local action of the voltaic cell, 171  
 Lodestone, discovery of, attributed to Chinese, 2  
   —, Lucretius and the, 2  
   —, properties of, 14  
 Loops, hysteresis, for various kinds of iron, 298  
 Low resistance Leclanché cell, 166  
   — —, measurement of, 746  
 Lucretius and the lodestone, 2  
 Luminous discs, 703

## M

- Machines, electrical, 85  
   —, hydro-electric, 87  
   —, influence, 88, 93  
   —, steam electric, 87  
 Magnets, 2  
 Magnet, action of, on iron filings, 15  
   —, — of, on polarised light, 317  
   —, Ampère's notion of a, 328  
   — and iron filings, 323  
   — and vacuum tube, 680  
   —, earth of a, 18  
   —, effect of breaking a, 321  
   —, electric bell, 334  
   —, lifting power of a, 23  
   —, magnetic moment of a, 28  
   —, normal reflection from pole of, 319  
   —, oblique reflection from pole of, 318  
   —, poles of a, 15  
   —, properties of, 15  
   —, Tesla's rotating-field, 611  
   —, rotated by a rotating field, 615  
 Magnetic and electric circuits, 331  
   — attraction, 17



- Magnetic battery, 23  
 — circuit, the, 281  
 — —, experiment on, 282  
 — — circuits of various dynamos, 499  
 — — curves, 30  
 — — of a circular loop, 278  
 — — of a solenoid, 27  
 — — round a straight current, 276  
 — — declination (*see* Declination, magnetic)  
 — — deviation, 17  
 — — effect of current, 144, 275  
 — — elements, 38  
 — — field, 27  
 — — —, energy of the, 424  
 — — —, intensity of, 27  
 — — of a current, 277  
 — — —, uniform, definition of, 36  
 — — fields, rotating, 610  
 — — flux, the, 283  
 — — —, production of a rotating, 612  
 — — horizontal needle, 16  
 — — inclination, or dip, 15  
 — — induction, 18, 322  
 — — influence at a distance, 24  
 — — laws and theory, 23  
 — — leakage, 500  
 — — measurement, 812  
 — — meridian, 15, 37  
 — — moment, 28  
 — — —, or armature reactions, 502  
 — — permeability (*see* Permeability, magnetic)  
 — — properties of alloys, 310 *et seq.*  
 — — — of iron, 286  
 — — — of various materials, 300  
 — — reluctance, 34, 283  
 — — remanence, 297  
 — — repulsion, 17  
 — — resistance, 283  
 — — retentivity, 297  
 — — saturation, 22  
 — — variation, 15, 37  
 — — unit defined, 27  
 Magnetisation by double or divided touch, 21  
 — — by earth, 4  
 — — by induction, 19  
 — — by lightning, 12  
 — — by single touch, 20  
 — — —, change of length on, 306 *et seq.*  
 — — — curve of copper alloy, 314  
 — — — curves of different materials, 287  
 — — —, effects of temperature on, 304  
 — — —, intensity of, 28  
 Magnetisation, residual (*see* Residual magnetisation)  
 — — —, stages of, 324  
 Magnetising coils, 505  
 — — —, force of a coil, 281  
 Magnetism, Ampère's theory of, 328  
 — — — and light, 316  
 — — —, early and classical reference to, 2  
 — — —, history of, 2  
 — — —, Ewing's theory of, 325  
 — — —, Hughes's theory of, 325  
 — — —, Maxwell's theory of, 323  
 — — —, Poisson's theory of, 322  
 — — —, properties of, 14  
 — — —, residual, 20  
 — — —, terrestrial, 37  
 — — —, theories of, 320  
 — — —, Weber's theory of, 322  
 — — —, Wiedemann's theory of, 323  
 Magnetite, 14  
 Magneto-electric induction, 416  
 — — —, Faraday's discovery of, 416  
 — — — — in moving wires, 481  
 — — — —, laws of, 420  
 Magneto-motive force, 281  
 Magneto-telephones, 454  
 Magnetometer, Kew, 38  
 Magnets, aging, 22; laminated, 23  
 — — —, artificial, 14  
 — — —, Ewing's experiments with groups of, 327  
 — — —, field (*see* Field magnets)  
 — — —, groups of, 326  
 — — —, methods of making, 20  
 — — —, mutual action of, 17  
 — — —, natural, 14  
 — — —, rotating-field, diagrams of, 613  
 — — —, scissors controlling, 717  
 — — —, steel for, 22  
 Magnification of deflections, optical, 712  
 Manchester dynamo, the, 521, 522  
 Manganese dioxide cells, 162  
 Marks enclosed arc lamp, 264  
 Materials, transparency of, 670  
 — — —, resistances of, 750 *et seq.*  
 Maxwell's method of measuring inductance, 789  
 — — —, theory of magnetism, 323  
 Mean values of sines for one loop of a "sine curve," 765  
 Measurement of capacity, 757, 797  
 — — — of energy, 807  
 — — — of form factor, 783  
 — — — of inductance, 784  
 — — — of liquid resistances, 743  
 — — — of power, 799  
 — — — factor, 809  
 Measurement of resistance, 360, 736  
 — — — of small c.c., 712  
 Measurements, electrical, 712  
 — — —, magnetic, 812  
 Measuring instruments, 370  
 Mechanical and electrical quantities, relations between, 603  
 — — — characteristics of motors, 602, 604  
 Medium, importance of the surounding, 537  
 — — —, influence of, 29, 32  
 Melloni's thermopile, 178  
 Mercury air pumps, 233  
 — — — arc, 270, 673  
 — — — —, A.C., 677  
 — — — —, colour of the, 678  
 — — — —, method of starting, 676  
 — — — —, modifications for A.C., 677  
 — — — —, plunger method of starting, 676  
 — — — —, "Sidebranch" method of starting, 676  
 — — — lamp, A.C., directly connected to mains, 678  
 — — — —, connections for A.C., 677  
 — — — unit resistance coil, 737  
 — — — vapour lamp, Cooper-Hewitt, 674  
 — — — rectifier, diagram of connections for a three-phase, 571  
 — — — —, early form, 570  
 — — — —, rectifiers, 569  
 — — — —, stratification, 692  
 Meridian, magnetic, 15, 37  
 Metallic filament lamps, 239  
 Metals, thermo-electric properties of, 175  
 Meter, Shallenberger's power, 806  
 "Metre" bridge, 739  
 Micrometer, electric, 309  
 — — —, Reiss' spark, 128  
 Microphone, Berliner's, 465  
 — — —, Blake's, 466  
 — — — circuit, simple, 462  
 — — — experiments, early, 447  
 — — — —, Hughes', 448, 459  
 — — —, Gower-Bell, 465  
 — — — transmitters, 459  
 — — — —, telephone circuit with, 462  
 Microphones, early, 463  
 — — —, Edison's carbon, 467  
 — — —, Hughes's carbon, 449  
 — — — without carbon, Hughes's, 449  
 Mirror, telescope and scale, 713

- Modes of producing electrification, 61
- Molecular shadow in ruptured glow lamp, 237
- Mono-phase alternate current motors, 606
- induction motors, 622
- Morley alternator, electro-magnet of, 338
- Morley's transformer, 438
- Morse, 390, 393
- alphabet, 405
- embossing instrument, 411
- key, 407
- receiver, 411
- Morse's first telegraph, 394
- — — writing, 395
- Morton's, Dr., commutator rectifier, 567
- Motor, c.c., armature reactions in, 595
- converters, 641
- —, diagram of connections of, 64.
- — in use in a sub-station, 643
- , electric, Elias's, 585
- , —, Dal Negro's first, 583
- , —, —, second, 584
- , —, Froment's, 586
- , —, Jacobi's, 585
- , —, lag of brushes in, 594
- , —, small, 599
- , experiment on the back e.m.f. of, 593
- , Ganz and Co.'s mono-phase, 609
- generator, Alioth, 632
- —, Elwell Parker, 633
- —, quadruple circuit, 634
- generators, 631
- , Griscom's, 599
- , Immisch, 596
- , induction, rotor, stator and other parts of, 621
- , maximum activity of, 602
- , poly-phase, driving a c.c. generator, 630
- , Rechniewski's mono-phase a.c., 608
- , self-starting synchronous, 610
- , shunt, mechanical characteristics of, 604
- , synchronous, definition of, 607
- , tramcar, 597
- , waterproof railway, 50 H.P., 598
- Motors, a.c., mono-phase, 606
- and dynamos, coupled, 628
- , c.c., 590
- , —, elementary theory of, 601
- Motors, early forms of modern, 595
- , electric, 583
- , —, definition of, 583
- , —, early, 583
- , —, efficiency of, 601, 605
- , —, historical notes on, 583
- , induction, 610
- , —, mono-phase, 622
- , mechanical characteristics of, 602, 604
- , poly-phase, 610, 621
- , rotating-field, 615
- , series, mechanical characteristics of, 604
- Moving-coil galvanometer, Ayrton-Mather, 719
- — with single pivot, Paul's, 720-721
- Multicellular electrostatic voltmeter, Kelvin's, 770
- Multiplier, the, 345
- Multipolar dynamos, 531
- rotating fields, 612
- — —, production of, with tri-phase currents, 614
- Musschenbroek, Pieter van, 8
- N
- Nalder's ammeter, 351
- Needle, magnetic, 16
- Negative pole, dark space at the, 683
- , positive and, electrification, 56
- Nernst non-carbon lamp, 229
- Nicholson and Carlisle's experiments, 190
- Nickel and cobalt, hysteresis loop of, 300
- —, magnetic properties of, 301
- Nitric acid cells, 160
- Nobili's astatic galvanometer, 347
- "Nodon" electric valve, 569
- Non-polarised relay, American, 405
- Norman, Robert, magnetic experiments of, 2
- North-seeking pole defined, 15
- O
- Obach's cell, 167
- Oepinus, condenser of, 126
- Oersted, Hans Christian, 12
- — —, discovery of, 12
- Ohm, George Simon, 12
- Ohm, definition of, 356
- Ohm, the practical unit of electric resistance, 183
- Ohm's law, application of, 514
- — of current flow, 180
- Ondographs, 781
- Open-coil armatures, 493
- winding, 493
- Opposing pressures, current from, 487
- Optical magnification of deflections, 712
- Oscillograph, apparatus for projecting curves, 779
- curves showing voltage and current waves, 780
- , Duddell permanent magnet, 774
- for high-voltage circuits, connections of, 778
- , principle of the vibrator of, 773
- vibrators, 775
- "Oscillographs," 764, 773
- Oscillations, electric, 646
- Oscillator, Hertz's, 663
- , Righi's, 668
- Oscillatory discharge, 98
- Overtone dynamos, 527
- Oudin's invention of the resonator, 657
- Ozone, production of, electrically, 137
- Ozonisers, 137
- P
- Pacinotti's, Dr. Antonio, description of a small electro-magnetic machine, 587
- Pane, Franklin's, 117
- Paramagnetic and diamagnetic bodies, 301
- Peltier effect, the, 173
- Peltier's bar, 176
- cross, 173
- Pendulum, electric, 57
- Period, 536
- Periodic changes, 536
- curves, complex cyclic, 539
- time, 536
- Permeability, 34, 285, 312
- curve of copper alloy, 314
- curves for iron, 285
- , effects of temperature on, 305
- , measurement of, 285
- Permittance, 545
- , inductance and, combined, 547
- Permutators, 643
- , Rougé-Faget, 644

Petrina, Professor F. A., and duplex telegraphy, 397  
 Phase and phase-difference, 541  
 —, splitting the, definition of, 626  
 Phenomena, elementary fundamental, 14  
 —, other radio-active, 711  
 Phosphorescence in a vacuum tube, 684  
 — with external poles, 686  
 Physics of the electric arc, 253  
 — of the glow lamp, 237  
 Picard and electrical luminosity, 6  
 Pidgeon influence machine, 103  
 Pile, discovery of, 12  
 —, voltaic, 146, 147  
 —, Zamboni, 55  
 Pixii's commutator, 471  
 — dynamo, principle of, 471  
 — —, Ritchie's, Clarke's, and Siemens' improvements on, 472  
 Planté, Gaston, 204  
 —, —, cell of, 204  
 —, —, large battery of, 208  
 —, —, original batteries of, 207  
 Plate machine, Winter's, 85  
 Plug resistance box, 358  
 — switch, high-insulation, 760  
 Poggendorff's rheochord, 357  
 Points, action of, 82  
 —, effects of, on a conductor, 84  
 Poisson's theory of magnetism, 322  
 Polar gap, armature iron in, 485  
 Polarisation, 159 *et seq.*  
 —, experiment in, 200  
 Polarised electro-magnets, 339  
 — light, action of a magnet on, 317  
 — relay, Siemens', 403-404  
 Polarising or analysing grating, 667  
 Poles of electro-magnet and current circulation, 331  
 —, magnetic, similar and dissimilar, 18  
 Poly-phase, A.C. transmission, 580  
 — circuits, simple, 552  
 — current power, 805  
 — currents, 548  
 — motors, 610  
 — working in mesh-connected generator, 553  
 — in star-connected generator, 553  
 Positive and negative electrification, 56  
 P.O. sounder, 409  
 P.O. Wheatstone bridge, 742  
 Potential and water level, analogy of, 112  
 — difference (P.D.) and sparking distances, 129  
 — — in the air, 139  
 — —, production of, 145, 146, 150  
 — differences, measurement of, 370  
 —, electric (*see* Electric potential)  
 Potentials of a dynamo, horizontal, 510  
 Potentiometer, diagram of, 362  
 — method, 362  
 Powders, electroscopic, 137  
 Power factor indicator, connections of a monophasic, 811  
 — —, — of, for balanced triphase circuits, 811  
 — — —, details of, 810  
 — — — E.E.C., 809  
 — —, measurement of, 809  
 — in an inductive circuit, 800  
 —, measurement of, 799  
 —, — of A.C., 805  
 —, — of, in three-phase circuit, 805  
 — meter, Shallenberger's, 806  
 — polyphase current, 805  
 Pressure, electrical, 362  
 — measurement of current, 768  
 Primary cell, development of the, 158 *et seq.*  
 — gas batteries, 203  
 Prime conductor, 7  
 Production of a current, conditions for, 144  
 Proof plane, 60  
 — —, theory of, 80  
 Public supply meter, Edison's, 384  
 Pulsating currents, 536  
 Pyro-electricity, 62

## Q

Quadrant electrometer, 374  
 — —, Lord Kelvin's, 374  
 Quadrature, 551  
 —, alternate currents in, 552  
 —, generator connections in, 551  
 Quadruple circuit motor generator, 634  
 Quantity of electricity, definition of unit, 341  
 — —, measurement of, 341

## R

Radiant matter, mechanical motion produced by, 688  
 — — shadow, 687  
 Radio-active bodies, 706  
 — phenomena, other, 711  
 Radio-activity, 706  
 Radiograph, localisation of imbedded bodies by, 699  
 — of foot showing needle, 696  
 — of hand, 698  
 — of lady's hand, 696  
 — of living head, 698  
 — of objects in a bag, 697  
 — of thorax, 699  
 — taken through black vulcanised fibre, 699  
 Radiography, stereoscopic, 700  
 —, — interrupter, 700  
 Radioscopes, 695  
 Radio-telegraphy (*see* Wireless telegraphy)  
 Radium, energy produced by, 709  
 Rayleigh's, Lord, H-pattern standard cell, 367  
 —, —, method of measuring inductance, 785  
 Rays  $\alpha$ , 707  
 —  $\beta$ , 708  
 —  $\gamma$ , 708  
 —, Becquerel, 706  
 —, kathode, Lenard's experiment with, 689  
 —, —, shadow cast by, 685  
 —, nature of the, 708  
 Reactance, 544  
 Reactions, armature, in a C.C. motor, 595  
 —, magnetic, 502  
 Réaumur, 8, 12  
 Recalescence of iron, 306  
 Receiver, Morse, 411  
 Receiving circuits, with decoder, 669  
 — instruments, 409  
 Rechinowski's mono-phase A.C. motor, 608  
 Recording instruments, 409  
 Rectifier, Dr. Morton's commutator, 567  
 Rectifiers, 565  
 —, electrolytic, 568  
 —, mercury vapour, 569  
 Reflection, double angle of, 715  
 Reflexion and interference, 664  
 — from curved surfaces, 666  
 Regenerative Röntgen ray tube, 695  
 Reiss, condenser of, 114  
 Reiss's electric calorimeter, 133  
 — telephone, 443



- Relay, American non-polarised, 403  
 — connections, telegraphic, 402  
 —, Wheatstone's, 392  
 Relays, non-polarised, 403  
 —, telegraphic, 401  
 Reluctance, magnetic, 34, 283  
 — of materials, 284  
 Remanence, magnetic, 297  
 Replenisher, 375  
 Repulsion, attraction and, magnetic, 6, 14, 17  
 —, mutual, by two kathode streams, 688  
 — of glow by a conductor, 682  
 Residual charge, 125  
 — magnetisation, 297, 299  
 — magnetism, 20  
 Resinous electrification, 7, 56  
 Resistance box, dial, 359  
 —, —, plug, 358  
 —, —, boxes, 358  
 —, —, coil and plug, 359  
 —, —, mercury unit, 737  
 —, —, standard, 737  
 —, —, —, with bare wire, 738  
 —, electric, 355  
 —, influence of temperature upon, 755  
 —, magnetic, 283  
 —, measurement of, 736  
 — of conductors, definition of, 182  
 —, —, laws of, 184  
 — of the arc, 255  
 —, specific, definition of, 183  
 —, units of, 356  
 Resistances, adjustable, 357  
 —, high, measurement of, 745  
 —, liquid, 741  
 —, low, measurement of, 746  
 —, —, —, by ammeter and voltmeter method, 749, 750  
 —, —, —, by differential galvanometer method, 749  
 —, —, —, by fall of potential, 748  
 —, measurement, 360  
 — of materials, 750 *et seq.*  
 Resonator, Hertz's, 664  
 —, Oudin's invention of, 657  
 Retentivity, magnetic (*see* Magnetic retentivity)  
 Return shock, 138  
 Revolving commutators, 565  
 Rheochord, Poggendorff's, 357  
 Rheographs, 781  
 Rheostat, 357  
 Richmann, Professor, 10  
 —, —, death of, 10  
 Riess, 58  
 —, induction apparatus of, 73  
 —, —, experiments of, 72  
 Righi's oscillator, 668  
 Ring armatures, 486  
 —, inductance of, effect of, 624  
 Röntgen or X-rays, 692  
 — ray tubes, 695  
 — rays and Becquerel rays, 710  
 Root mean square (R.M.S.), definition of, 766  
 Rotary converters, 635  
 —, —, starting, 639  
 —, —, Westinghouse, 500 k.w., 640  
 —, —, —, armature of, 641  
 —, —, —, rotor of starting motor of, 641  
 —, —, —, (330 H.P.) A.C. side, 638  
 —, —, —, (330 H.P.) C.C. side, 637  
 Rotating copper cylinder, slotted and lined with laminated iron, 618  
 — field magnet rotated by, 615  
 — magnets, diagram of, 613  
 — motors, 615  
 —, —, multipolar, production of a, with tri-phase currents, 614  
 — magnetic field, copper cylinder placed in, 617  
 — fields, 610  
 — flux, production of a, 612  
 Rotations, Arago's, 422  
 —, —, explanations of, 616  
 — of light about a magnet in a vacuum tube, 680  
 Rotor, definition of, 61;  
 —, drum-wound, 620  
 —, iron core, driving spider and shaft of, 619  
 —, squirrel cage, 615  
 —, wound, with slip rings, 620  
 Rougé-Faget permutator, 644  
 Rücker and Thorpe's magnetic survey, 43  
 Rücker's experiments on electrostatic strain, 66, 67, 68  
 Ruhmkorff coil, 429  
 —, —, theory of, 431  
 Ruhmkorff's inductorium, 429
- S
- St. Elmo's fire, 5, 141  
 —, —, coil producing, 703  
 Saturation current, 705  
 —, magnetic (*see* Magnetic saturation)  
 — voltage, 705  
 Schiller and electric oscillations, 647  
 Schilling, Baron, 389  
 Schweigger, 12  
 Scissors controlling magnets, 717  
 Secohmmeter, the, 790  
 — arranged for capacity measurements, 799  
 —, Ayrton and Perry's, 791  
 Secondary batteries, 200  
 — cells, charging of, 215  
 —, —, history of, 202  
 —, —, modern, 211  
 —, —, mounting of, 213  
 — generators, 435  
 Seebeck, Professor, 12  
 — effect, (table), 174  
 — thermo-electric apparatus, 174  
 Self-induction, 423  
 —, experiment on, 423  
 Self-starting synchronous motor, 610  
 Sensitive galvanometers, 715  
 — reflecting galvanometer, 716  
 Separation, energy of electrical, 72  
 Series, capacity of condensers in, 124  
 —, connecting up, 184  
 — dynamo, characteristic curves of, 508  
 —, —, efficiency of, 514  
 — motor, mechanical characteristics of, 604  
 Serrin's lamp, 248  
 Sewage, purification of, by electricity, 220  
 Shadow cast by Kathode rays, 685  
 —, "Radiant Matter," 687  
 Shallenberger's meter, electrical circuits of, 806  
 —, —, interior of, 806  
 Shock, the return, 138  
 Shunt box, ordinary, 726  
 —, —, connections of, 725  
 —, —, boxes, 725  
 —, —, universal, 726  
 —, —, —, connections of, 727  
 —, —, —, dial pattern, 728  
 —, —, definition of a, 189  
 — dynamo, efficiency of, 515  
 — motor, mechanical characteristics of, 604  
 Shunting galvanometer, 352, 725  
 Shunts, cross, 353  
 —, water analogies to, 353  
 Siemens, Charles William, 476 (*footnote*)  
 —, Wernher, 476 (*footnote*)  
 Siemens' alternator, 557  
 —, —, diagrams of, 558  
 —, —, with separate exciter, 558  
 — and Halsk's experiments with the electric arc, 244  
 — cable transformer, 436

- Siemens' cylindrical armature, 474  
 — electric smelting apparatus, 272  
 — electro-dynamometer, 733  
 — polarised relay, 403-4  
 — self-exciting dynamo, 477  
 Signals, telegraphic, 405  
 Simple a.c., elementary laws of, 537  
 — c.c., elementary laws of, 180  
 — dynamos, 483  
 — reflecting galvanometer, 717  
 Sine curve, mean values of sines for one loop of, 765  
 — —, simple construction for, 540  
 — curves, 539  
 — law curves (*see* Sine curves)  
 Single-needle instrument, 411  
 Single-phase transmission, diagram of, 579  
 — a.c. transmission, 578  
 Smee's battery, 160  
 — cell, 160  
 — experiments, 159  
 Solar spectrum, energy curve, 253  
 Solenoid, a simple, 278  
 —, magnetic curves of, 279  
 — repelled by magnet, 279  
 Solenoids, 278  
 — behave like magnets, 279  
 Sömmering, Samuel Thomas, 388  
 Sömmering's telegraph, 388  
 Sounder, "Bell" form of, 410  
 —, P.O., 409  
 —, telegraphic, 409  
 Source of E.M.F. in the arc, 259  
 Sources of light efficiency of, 251  
 South-seeking pole defined, 15  
 Spangled tube, 661  
 Spark, electric, 82  
 —, —, in air, 658  
 —, forked, 659  
 —, micrometer, Reiss's, 129  
 —, straight, 659  
 Sparking distances, 129  
 — and P.D., 129  
 — in air, 128  
 —, Rijke on, 129  
 —, table of, 129  
 — voltages at different distances, table of, 130  
 "Speaking galvanometer," 715  
 Specific resistance, definition of, 183  
 — resistances of materials, 751  
*et seq.*  
 Spectrum energy curves, 252-3  
 Speech, transmission of, 450  
 Speed, rate of, distinction between the most economical and the most rapid, 604  
 Spencer's experiments, 216  
 Spherical condenser, Faraday's, 116  
 Spintharoscope, 707  
 Splitting the phase, definition of, 626  
 Sprengel's mercury air pump, 236  
 — — —, principle of, 236  
 Square plate, Chladni's figures for, 452  
 — plates, simple vibrations of, 452  
 Squirrel-cage rotor, 618  
 — —, Johnson and Phillip's, 618  
 "Staggered" poles, electro-magnet with, 339  
 Staitte's 1848 arc lamp, 245  
 Standard cells, 364-5  
 — coils, 357  
 — galvanometers, 729  
 — resistance coils, 737  
 Standards of inductance, 794  
 — —, adjustable, 794  
 — —, fixed, 796  
 Starck's discovery of alloys, 313  
 Starting rotary converters, 639  
 Stator, definition of, 617  
 Steam electric machine, 87  
 Steel for magnets, 22  
 Steels, unmagnetisable, 288  
 Steinmetz's law of coercive force, 296  
 — — of hysteresis waste, 296  
 Step-by-step telegraph, Wheatstone, 393  
 Stereoscopic effects, circuit maker for, 701  
 — interrupter, 700  
 — radiography, 700  
 Storage of electrostatic energy, 109  
 Strain lines between rubbed and separated discs, 71  
 Strains, electric, 65  
 Stratification, explanation of, 691  
 —, hydrogen, 692  
 —, mercury, 692  
 — of the electric light, 679  
 Stratified discharges, 679  
 Straw electroscope, 11  
 Stress, electrical, 72  
 Striking the arc, 254  
 Sturgeon, discoveries of, in electro-magnetism, 280  
 —, electro-magnets of, 281  
 Submarine telegraphy, early, 398  
 Suspended coil galvanometer, Maxwell's 718  
 Swan's glow lamp, 231  
 Swinburne's "Hedgehog" transformer, 436  
 — non-inductive wattmeter, 802  
 Swinton's tube for a.c., 694  
 Symmer, Robert, 10  
 — —, theory of, 10  
 Synchronous mono-phase induction motor, 626  
 — motor, definition of, 607  
 — —, self-starting, 610
- T
- Tangent galvanometer, 729  
 — —, standard, 731  
 Tanning, application of electricity to, 220  
 Tantalum filament, effect of various currents on, 241  
 Tapper, 408  
 Telegraph, electric, 387  
 Telegraphic circuit, simple, 400  
 — relay connections, 402  
 — relays, 401  
 — signalling, connections for, in both directions, 400  
 — signals, 405  
 — working, simple, 400  
 Telegraphy, cable, 397  
 —, duplex, 396  
 —, multiplex, 396  
 —, quadruplex, 397  
 —, radio-, 670  
 —, wireless, 670  
 Telephone, 443  
 —, Ader's, 457  
 —, Bell's, 454  
 —, early, 446  
 —, — experiments with, 444  
 —, — second, 447  
 — circuit with microphone transmitters, 462  
 —, Gower's, 456  
 —, Gray's, 447, 458  
 —, historical notes, 443  
 — induction coil, 433  
 —, Reiss's, 443  
 Temperature effect on hysteresis, 296  
 —, influence of, upon resistance, 755  
 — of arc electrodes, 254  
 — of recalcence, 306  
 —, permeability at high, 305  
 Terrestrial magnetism, 37  
 Tesla, Mr. Nikola, experiments of, 647, 648  
 Tesla's apparatus, diagrams of, 657, 658  
 — rotating-field magnet, 611  
 — split-phase motor, 627  
 — transformer, 437  
 Thales of Miletus, 4  
 Theory of light, electro-magnetic, 661

- Thermal effect of current, 144,  
222  
— production of the electric  
current, 173  
Thermo-electric circuit, energy  
transformations in, 175  
— inversion, 176  
— properties of metals, 175  
Thermo-electricity, 173  
—, discovery of, 12  
Thermopiles, 177  
Thomson effect, 177  
—, Professor Elihu, experi-  
ments of, 647, 648  
—, Sir J. J., experiments of,  
647, 648  
Thomson's energy meter, 382  
— mono-phase induction motor,  
626  
Thorax, radiograph of, 699  
Thorpe's, Rücker and, magnetic  
survey, 43  
Three-phase currents, curves for,  
550  
—, generators for, 549  
Time-constant of the circuit, 768  
(note)  
Tongs, discharging, 128  
Töpler's mercury air pump, 235  
Torpedo, electricity of, 11  
Torque and current, relation be-  
tween, 603  
—, or couple, 28  
—, permanent, exerted on cop-  
per ring, 625  
Torricelli's experiment, 233  
— vacuum, 233  
Torsion balance, 24, 62  
—, Coulomb's, 25, 62, 63  
—, construction of,  
11  
—, magnetic, 26  
—, electrometer, Kohlrausch's,  
373  
Tramcar motor, 597  
Transfer and transformation of  
energy, 425  
Transformations of energy, 151  
Transformer, cable, 436  
—, c.c. (coupled plant), 629  
—, Ferranti's, 440  
—, "Hedgehog," 436  
—, Mordey's, 438  
—, Tesla, 437  
Transformers, a.c. or static, 433  
— available for transmission  
of power, 574  
—, closed-circuit, 438  
—, definition of, 574  
—, history of static, 434  
—, kinetic, 628  
—, open-circuit, 436  
Transmission, a.c., polyphase, 580  
—, c.c., 576  
Transmission, Lauffen-Frankfort,  
580  
— of power, electric, 572  
—, —, fundamental prin-  
ciples, 572  
—, —, transformers available  
for, 574  
— of speech, electric, 450  
—, single-phase, diagram of,  
579  
—, systems of, 575  
Transmitter, Ader's, 464  
—, Berliner's, 448, 465  
—, Crossley's, 464  
—, Hunning's, 469  
Transmitters, telegraphic, 467  
Transmutation of elements, 709  
Transparency of materials, 670  
Tribie, Gladstone and, on second-  
ary cells, 210  
Tube, "Focus," 693  
— with separate anti-kathode  
and anode, 694  
Tubes, Geissler's, 672  
—, lightning, 139  
Tudsbury influence machine, 108  
Two-fluid theory, 320  
Two kinds of electrification, 7,  
55  
— of electricity, 10  
Two-part commutator or collec-  
tor, 484  
Two-phase currents, generators  
of, 551
- U
- Ultra-violet waves, discharge by,  
704  
Uniform magnetic field, defini-  
tion of, 36  
Unit electric current, definition  
of, 195  
— jar, Lane's, 119  
— magnetic field defined, 27  
— pole, definition of, 27  
— of capacity, 123  
— of energy, Board of Trade,  
definition of, 381  
— of inductance, 785  
— of resistance, 356  
— quantity of electricity, 64  
—, definition, 195  
Unmagnetisable steels, 288
- V
- Vacuum lamp, Aron's, 673  
— tube, magnet and, 680  
—, magnets affect the dis-  
charges in, 679  
—, phosphorescence in a,  
684
- Vacuum tube, rotation of light  
about magnet in, 680  
"Valve," connections for electro-  
lytic or electric, 569  
Van 't Hoff, 199  
Variation charts, 40  
—, magnetic, 15, 37  
Varley, S. A., and self-exciting  
c.c. dynamo, 476  
Velocity, ionic, 199  
Vibrations of circular plates, 451  
— of square plates, simple, 452  
Viscous hysteresis, 297  
Vitrous electrification, 7, 56  
Volt, the practical unit of elec-  
tric pressure, 183  
Volt-amperes, 378  
Volta, Alessandro, 12  
Volta's contact law, 157  
— "crown of cups," 147  
— experiments, 146  
Voltage, saturation, 705  
— sparking, at different dis-  
tances, table of, 130  
Voltages, spark-length, for dif-  
ferent electrodes, 131  
Voltaic cell, local action of, 173  
—, theories of, 150  
—, typical, 150  
—, energy of trans-  
formation in, 151  
— circuit and water circuit,  
analogy between, 181  
— pile, 146, 147  
—, Leyden jar and, cur-  
rents from, compared, 148  
Voltmeter, 188, 341  
—, copper, 343  
— for measuring coulombs,  
341  
— measurement of currents,  
344  
—, silver, 342  
Volts and ammeters, 348  
—, electro-magnetic, 370  
—, electrostatic, 377, 769  
—, hot-wire, 371, 772  
Von Lang's experiments with  
the arc, 258  
Von Steinheil, Carl August, 390  
— and earth returns, 391  
Voss influence machine, 96, 97  
—, action of, 98  
—, self-reversal of,  
98
- W
- Walsh, Dr. John, 10  
Water circuit and voltaic cir-  
cuit, analogy between, 181  
—, decomposed electrically,  
13  
—, divided, circuit,



- Water level and potential, analogy of, 112
- Waterproof railway motor, 50  
H.P., 598
- Watson, E. A., 130  
—, Sir William, 8
- Watt, definition of the, 378
- Wattmeter, 379, 801  
—, connections of an electro-magnetic, 380  
—, deflectional, 803  
—, explanation of, 379  
—, Swinburne's non-inductive, 802
- Wave form in primary circuit of coil, 651  
— forms, 772  
— —, analysis of, 782  
— —, harmonics of, 782  
— —, projection of, 778
- Waves, electric, 660  
—, —, polarisation of, 667  
—, —, refraction of, 666  
—, —, reflexion of, 664  
—, interference of direct and reflected, 665  
—, ultra-violet, discharge by, 704
- Weber's theory of magnetism, 322
- Weight vibrating on a horizontal surface, 646
- Weights, atomic, definition of, 194
- Westinghouse poly-phase induction motor, 623  
— 500 K.W. rotary converters, 640  
— — — —, armature of, 641  
— — — —, rotor of starting motor of, 641
- Wheatstone bridge, 355, 361  
— — coils, 741  
— —, connections of, 741  
— —, Post Office, 742  
— —, principle of, 355  
— bridges, 739  
— relay, 392  
—, Sir Charles, 390  
— step-by-step telegraph, 393
- Wiedemann's theory of magnetism, 323
- Wilde's dynamo, 475
- Wilson, Benjamin, 7
- Wimshurst influence machines, 98-102, 105-7  
— eighty-plate influence machine, 102  
— later influence machines, 104-5  
— twelve-plate influence machine, 101  
— — — —, discharge from, 660
- Wind, electric, 83
- Winding, drum (*see* Drum winding)
- Winding, open-coil (*see* Open-coil winding)
- Windmill, electric, 83
- Winkler, Johann, 7  
—, —, lightning conductor of, 9
- Winter's electric machine, 85
- Wireless or radio-telegraphy, 670
- Wires, resistance of, 183
- Wollaston's battery, 149
- Wound rotor with slip rings, 620
- Wright's 1845 arc lamp, 245
- Wullner and electric oscillations, 647

## X

- X-rays, 692  
—, effects of, 698  
—, properties of, 693  
— tube, Swinton's, 694  
— tubes, regenerative, 695  
—, uses of, 699  
— work, screens for, 696

## Z

- Zeeman, effect, the, 319
- Zero of electric potential, 113
- Zipernowsky, 557

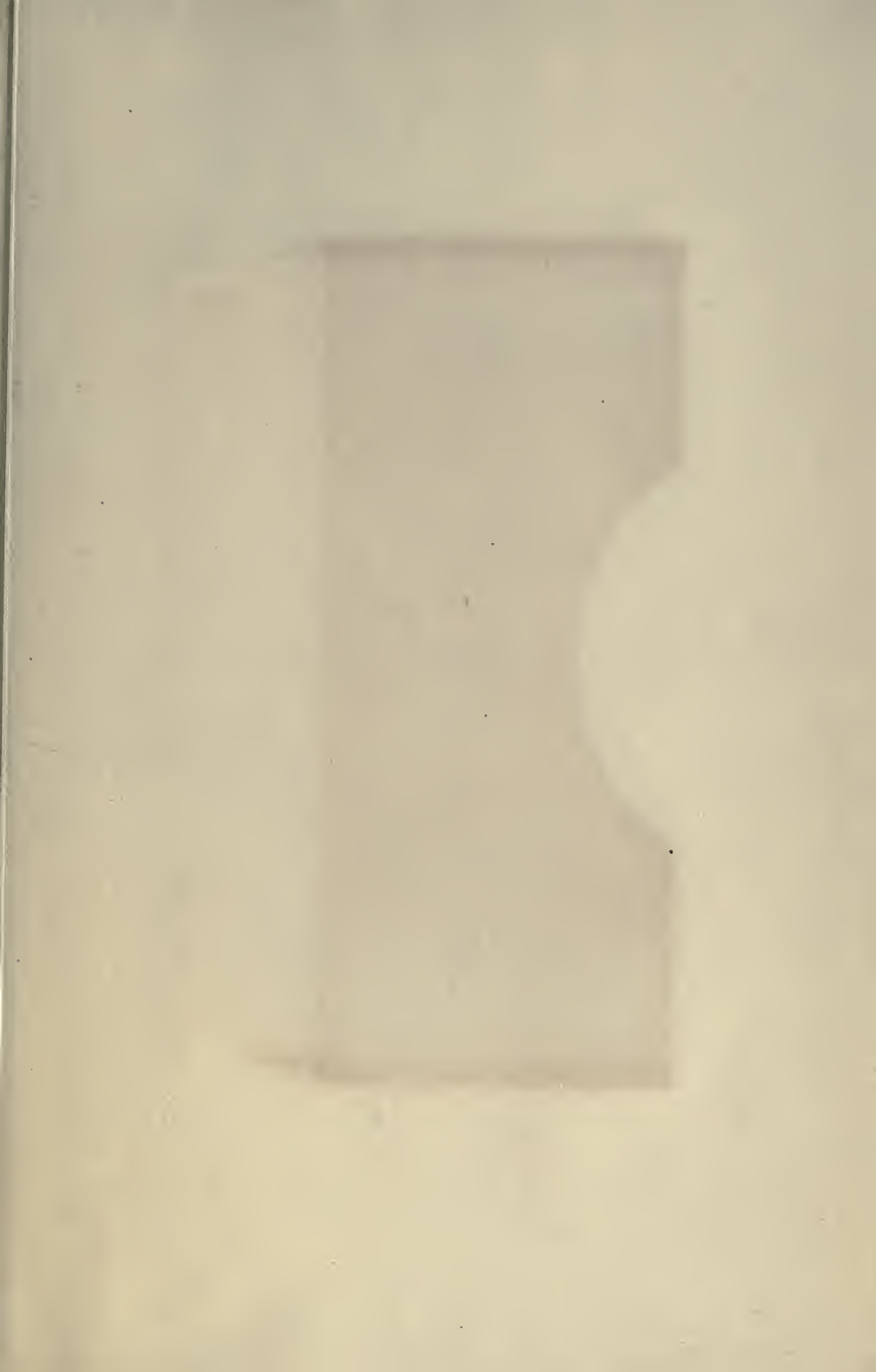





University of Toronto  
Library

---

DO NOT  
REMOVE  
THE  
CARD  
FROM  
THIS  
POCKET

Acme Library Card Pocket  
Under Pat. "Ref. Index File"  
Made by LIBRARY BUREAU

